



Consultancy Services for Mangrove Restoration of Sungei Durian Ponds Environmental Impact Assessment (EIA)

Final Report

National Parks Board (NParks)

Project reference: NPARKS/N/39/2017
Project number: 60579645

08 August 2023

Quality information

Prepared by

Dr. Liang Liang
Ms. Celine Cho
(Hydrology Specialist)
Ms. Sheryl Seet
Ms. Veron Pwa
(Biodiversity Specialist)

Checked by

Dr. Hoai Thanh Nguyen
(Hydrology Reviewer)
Mr. Derek Yap
(Biodiversity Reviewer)

Verified by

Dr. Hoai Thanh Nguyen
Dr. Liang Liang
(Overall EIA Reviewer)

Approved by

Ms. Jagriti Dawra
(Environment Department
Head)

Prepared for:

National Parks Board (NParks)
1 Cluny Road
Singapore 259569

Prepared by:

AECOM Singapore Pte Ltd
300 Beach Road, #23-00 The Concourse, 199555
Singapore
aecom.com

© 2023 AECOM Singapore Pte Ltd. All Rights Reserved.

This document has been prepared by AECOM Singapore Pte Ltd ("AECOM") for sole use of our client (the "Client") in accordance with generally accepted consultancy principles, and the terms of reference agreed between AECOM and the Client. Any information provided by third parties and referred to herein has not been checked or verified by AECOM, unless otherwise expressly stated in the document. No third party may rely upon this document without the prior and express written agreement of AECOM. The information contained in this document originally produced by AECOM Singapore Pte. Ltd. ("AECOM") was produced solely for the use of the Client and was prepared to assist in the Consultancy Services for Mangrove Restoration of Sungei Durian Ponds Environmental Impact Assessment (EIA).

Neither AECOM nor its parent corporation, or its affiliates, (a) makes any warranty, expressed or implied, with respect to the use of any information or methods disclosed in this document or (b) assumes any liability with respect to the use of any information or methods disclosed in this document. Any recipient of this document, by their acceptance or use of this document, releases AECOM, its parent corporation, and its and their affiliates from any liability for direct, indirect, consequential or special loss or damage whether arising in contract, warranty, express or implied, tort or otherwise, and irrespective of fault, negligence and strict liability.

AECOM undertakes no duty to, nor accepts any responsibility to, any other party who may rely upon such information unless otherwise agreed or consented to by AECOM in writing (including, without limitation, in the form of a reliance letter) herein or in a separate document. Any party who is entitled to rely on this document may do so only on the document in its entirety and not on any excerpt or summary. Entitlement to rely upon this document is conditional upon the entitled party accepting full responsibility and not holding AECOM liable in any way for any impacts on its work product for the Consultancy Services for Mangrove Restoration of Sungei Durian Ponds Environmental Impact Assessment (EIA) arising from changes in "external" factors such as changes in government policy, in the pricing of goods and materials or changes in the owner's policy affecting the operation of the project.

This document may include "forward-looking statements". These statements relate to AECOM's expectations, beliefs, intentions or strategies regarding the future. These statements may be identified by the use of words like "anticipate," "believe," "estimate," "expect," "intend," "may," "plan," "project," "will," "should," "seek," and similar expressions. The forward-looking statements reflect AECOM's views and assumptions with respect to future events as of the date of this report and are subject to future economic conditions, and other risks and uncertainties. Actual and future results and trends could differ materially from those set forth in such statements due to various factors, including, without limitation, those discussed in this report. These factors are beyond AECOM's ability to control or predict. No section or element of this document produced by AECOM may be removed from this document, reproduced, electronically stored or transmitted in any form by parties other than those for whom the document has been prepared without the written permission of AECOM.

Table of Contents

1	Executive Summary	15
2	Introduction	22
	2.1 Scope of Work	22
	2.2 Report Structure	23
	2.3 EIA Schedule	23
	2.4 Study Limitations, Assumptions and Constraints	23
3	Project Description	25
	3.1 Project Location.....	25
	3.2 Historical Land Use.....	27
	3.3 Current Land Use	28
	3.4 Project Background	28
	3.5 Principles of Ecological Mangrove Restoration Method.....	29
	3.6 Prospective Development Plans	30
	3.6.1 Overview of Development Plans.....	30
	3.6.2 Earth Filling Works at Ponds.....	32
	3.6.3 Improvement Works for Site Hydrology and Hydrodynamics.....	35
	3.6.4 Improvement Works for Public Access and Amenities	38
	3.7 Proposed Activities During Construction Phase.....	39
	3.7.1 Channel between Pond 1 and Pond 2	39
	3.7.2 Earth Filling Works at Ponds.....	39
	3.7.3 Construction of Drain Inlets	44
	3.7.4 Construction of Gabion Blocks.....	44
	3.7.5 Construction of Public Access Infrastructure and Amenities	44
	3.8 Proposed Activities During Operational Phase	45
	3.9 Project Schedule	45
	3.10 Other Major Concurrent Developments	45
4	Relevant Regulatory Framework, International Standards and Guidelines.....	49
5	EIA Approach and Methodology	53
	5.1 Approach	53
	5.2 Scoping of EIA.....	54
	5.2.1 Identification of EIA Study Area.....	54
	5.2.2 Identification and Categorization of Sensitive Receptors.....	55
	5.3 Data Collection and Analysis	58
	5.3.1 Sample collection and Survey Locations	58
	5.3.2 Secondary Data Collection	58
	5.4 EIA Assessment Methodology	59
	5.4.1 Prediction of Impacts	59
	5.4.2 Evaluation of Impacts	62
	5.5 Mitigation of Impacts and Environmental Monitoring and Management Plan (EMMP)	65
	5.6 Evaluation of Cumulative Impacts	66
	5.7 Stakeholder and Public Engagements.....	66
6	Biodiversity	67
	6.1 Introduction.....	67
	6.2 Methodology	67
	6.2.1 Desktop Research	67
	6.2.2 Field Assessment.....	68
	6.2.3 Data Analyses.....	76
	6.3 Baseline Findings	77
	6.3.1 Habitat Types.....	77
	6.3.2 Flora Inventory.....	84

6.3.3	Faunistic Field Findings	89
6.4	Assessment of Ecological Values	104
6.4.1	Habitat	105
6.4.2	Flora	107
6.4.3	Fauna	108
6.5	Potential Sources of Biodiversity Impacts	108
6.6	Identification of Biodiversity Sensitive Receptor	111
6.6.1	Habitats	111
6.6.2	Flora	111
6.6.3	Fauna	111
6.7	Minimum Control Measures	111
6.8	Prediction and Evaluation of Biodiversity Impact	112
6.8.1	Positive Impacts	112
6.8.2	Construction Phase	113
6.8.3	Operational Phase	119
6.9	Recommended Mitigation Measures	122
6.9.1	Design Phase	122
6.9.2	Construction Phase	123
6.9.3	Operational Phase	124
6.10	Residual Impacts	124
6.10.1	Construction Phase	124
6.10.2	Operational Phase	126
6.11	Cumulative Impacts from Other Major Concurrent Projects	127
6.12	Summary of Key Findings	128
7	Marine Water	129
7.1	Introduction	129
7.2	Methodology and Assumptions	129
7.2.1	Marine Water and Sediment Baseline Surveys	129
7.2.2	Underwater Noise	138
7.2.3	Baseline Data Analysis and Assessment	140
7.2.4	Methodology for Marine Water Impact Assessment	144
7.3	Potential Sources of Marine Water Impacts	145
7.3.1	Construction Phase	145
7.3.2	Operational Phase	147
7.4	Baseline Findings	147
7.4.1	Topological and Hydrological Conditions	147
7.4.2	Hydrodynamics	152
7.4.3	Marine Sediments	157
7.4.4	Water Quality	164
7.4.5	Underwater Noise	175
7.5	Identification of Marine Water Sensitive Receptor	178
7.5.1	Construction Phase	178
7.5.2	Operational Phase	182
7.6	Minimum Controls	183
7.6.1	Construction Phase	183
7.6.2	Operational Phase	187
7.7	Prediction and Evaluation of Marine Water Impact	188
7.7.1	Construction Phase	188
7.7.2	Operational Phase	198
7.8	Recommended Mitigation Measures	202
7.8.1	Construction Phase	202
7.8.2	Operational Phase	202

7.9	Residual Impacts	203
7.10	Cumulative Impacts from Other Major Concurrent Projects.....	205
7.11	Summary of Key Findings.....	205
8	Environmental Monitoring and Management Plan.....	209
8.1	EMMP Objectives	209
8.2	Project Organisation during the Construction Phase	209
8.3	Project Organisation during the Operational Phase.....	210
8.4	Roles and Responsibilities of the EMMP for the Construction Phase.....	211
8.4.1	Technical Agencies	211
8.4.2	Project Owner (NParks) and Resident Technical Officer.....	211
8.4.3	The Superintending Officer (SO)	211
8.4.4	The Contractor.....	211
8.4.5	The Environmental Control Officer (ECO).....	212
8.4.6	The Environmental, Health and Safety Officer (EHS Officer).....	213
8.4.7	Arborist, Floral Specialist and Fauna Specialist.....	213
8.5	Roles and Responsibilities of the EMMP for the Operational Phase	213
8.5.1	Technical Agencies	213
8.5.2	Project Owner	213
8.5.3	Environmental Health and Safety Officer (or Equivalent).....	214
8.6	Construction Site Audit	214
8.6.1	Internal Site Inspection/Audit by ECO.....	214
8.6.2	External Environmental Audit by Independent EMMP Consultant	214
8.7	Operational Phase Audit.....	215
8.8	Complaint Handling	215
8.8.1	Construction Phase	215
8.8.2	Operational Phase	216
8.9	Biodiversity Monitoring Program Requirements.....	216
8.9.1	Construction Phase	216
8.9.2	Operational Phase	224
8.10	Marine Water Monitoring Program Requirements.....	225
8.10.1	Construction Phase	225
8.10.2	Operational Phase	228
8.11	Proposed EMMP	230
8.11.1	Construction Phase	231
8.11.2	Operational Phase	236
9	Stakeholder Engagement.....	237
10	Conclusion	238
11	References	242
11.1	Legislations, Standards and Guidelines.....	242
11.2	Websites.....	244
11.3	Publications	245
11.4	Maps.....	250
11.5	Others.....	250

Figures

Figure 1-1 Prospective development plan in the Project Site	15
Figure 1-2 Distribution of habitats, vegetation and flora species of conservation significance within Study Area.	16
Figure 1-3 Locations of faunal species of conservation significance, including camera trap records.....	16
Figure 3-1 Location of Project Site	26
Figure 3-2 Maps showing the historical land use of the Project Site and its vicinity in (A) 1943, (B) 1969, (C) 1993 and (D) 2005 [M-2].	27
Figure 3-3 Photos of existing site conditions (A) Pond 3 at low tide, (B) Mangroves growing within Pond 1, (C) Mangroves growing along the bunds between Pond 1 and Pond 2, (D) Broken sluice gate at south of Pond 1, (E) Severe erosion of bunds near the opening of Pond 3, and (F) An opening formed between two sluice gates at the south of Pond 1 and Pond 2.....	28
Figure 3-4 Overall layout plan of proposed developments at Project Site.....	31
Figure 3-5 Conceptual design of earth filling works.....	32
Figure 3-6 Cross-sectional area of mangrove islands	33
Figure 3-7 3D rendering of Sg. Durian Ponds before and just after construction.	34
Figure 3-8 3D rendering of Sg. Durian Ponds after construction and after mangrove establishment.	34
Figure 3-9 Layout plan of proposed drain inlets: (A) Drain inlet 1 at Pond 2, (B) Drain inlet 2 at Pond 3, (C) Sub-catchment areas of drain inlet 1 and drain inlet 2.....	35
Figure 3-10 Cross-sectional view of proposed drain inlet 1 at Pond 2.	36
Figure 3-11 Cross-sectional view of proposed drain inlet 2 at Pond 3.....	36
Figure 3-12 (A) Plan view of gabion block walls at Pond 1 and Pond 2 openings, (B) Isometric view of gabion block walls.....	37
Figure 3-13 Section view of gabion block walls.....	37
Figure 3-14 Plan view of the section of the bund wall that will be removed.	38
Figure 3-15 Location of site infrastructure and amenities.....	39
Figure 3-16 (A) Location of proposed shelter, (b) Section view of shelter.	39
Figure 3-17 Overview of transportation process of the dredged material to the Project Site.....	40
Figure 3-18 Map of the restriction zone of Chek Jawa Wetlands (source: MPA).....	41
Figure 3-19 An example of a flattop barge.	41
Figure 3-20 An example of a modular barge.	42
Figure 3-21 Temporary staging area of fill material.	43
Figure 3-22 An example of an amphibious excavator.....	44
Figure 3-23 Locations of construction projects in the vicinity of Project Site.....	48
Figure 5-1 Overall EIA workflow.	53
Figure 5-2 Mitigation hierarchy.	66
Figure 6-1 Location of terrestrial and aquatic sampling units	72
Figure 6-2 Example of a camera trap setup.	74
Figure 6-3 Photographs showing examples of A) canopy mist net and (B) ground harp trap deployed during bat trapping.....	75
Figure 6-4 (A) Quadrat sampling along 15-m transect, (B) visual survey of the vicinity within the 15-m diameter circle, (C) example of quadrat sampling in the mudflat	76
Figure 6-5 Habitats and vegetation distribution within Study Area.	78
Figure 6-6 Site photos representative of the abandoned-land forest within the Study Area.....	79
Figure 6-7 Site photos representative of the mangrove around the disused ponds within the Study Area.....	80
Figure 6-8 Mangrove forest east of Pond 1.....	80
Figure 6-9 Mangrove dominated by nipah palm (<i>Nypa fruticans</i>).....	81
Figure 6-10 Site photos representative of the scrubland and herbaceous vegetation within the Study Area.	81
Figure 6-11 (A) Site photos representative of the soft sediment seabed within the Study Area and (B) spoon seagrass (<i>Halophila ovalis</i>).	82
Figure 6-12 Site photos representative of the Marine Area within the Study Area.	83
Figure 6-13 Site photos representative of infrastructure within the Study Area.....	83
Figure 6-14 Nationally Vulnerable A) <i>Symplocos fasciculata</i> and B) <i>Utania nervosa</i>	85
Figure 6-15 Distribution of flora species of conservation significance that are naturally occurring in the Study Area.	86
Figure 6-16 Distribution of significant large trees within the Study Area.....	88
Figure 6-17 Locations of faunal species of conservation significance, excluding camera trap records.....	92
Figure 6-18 Odonates found within Sungei Durian. A) Mangrove dwarf (<i>Raphismia bispina</i>), B) mangrove marshal (<i>Pornothemis starrei</i>), C) Arthur's midget (<i>Mortonagrion arthuri</i>) and D) variable sprite (<i>Argiocnemis rubescens rubeola</i>).....	93

Figure 6-19 Conservation significant butterflies found within Sungei Durian. A) Malayan nawab (<i>Polyura moori moori</i>) and B) common jay (<i>Graphium doson evemonides</i>).	94
Figure 6-20 Frogs found within Sungei Durian A) <i>Polypedates leucomystax</i> , B) <i>Fejervarya cancrivora</i>	94
Figure 6-21 Snakes found within Sungei Durian A) Striped bronzeback (<i>Dendrelaphis caudolineatus</i>), B) White-bellied blind snake (<i>Argyrophis muelleri</i>), C) Oriental whip snake (<i>Ahaetulla prasina</i>).....	95
Figure 6-22 Birds found within Sungei Durian A) Great billed heron (<i>Ardea sumatrana</i>), B) Grey heron (<i>Ardea cinerea</i>), C) Black capped kingfisher (<i>Halcyon pileata</i>) and D) Sunda pygmy woodpecker (<i>Yungipicus moluccensis</i>).	96
Figure 6-23 Mammals found within Sungei Durian. A) Smooth-coated otter (<i>Lutrogale perspicillata</i>), B) Wild boar (<i>Sus scrofa</i>) foraging in mudflat.	97
Figure 6-24 Fish found within Sungei Durian. A) Goby specie (<i>Pseudogobius javanicus</i>), B) Yellow-spotted mudskipper (<i>Periophthalmus walailakae</i>), C) Picklehandle baraccuda (<i>Sphyræna jello</i>), and D) Kops' glass perchlet (<i>Ambassis kopsii</i>).	99
Figure 6-25 Decapods found within Sungei Durian. A) <i>Clibanarius longitarsus</i> , B) <i>Paracleistostoma depressum</i> , C) <i>Praosia punctata</i> and D) <i>Gelasimus vocans</i>	100
Figure 6-26 Molluscs found within Sungei Durian. A) Dubious nerite (<i>Clithon oualaniensis</i>), B) <i>Pirenella alata</i> <i>Pirenella cingulate</i> , C) <i>Anadara antiquata</i> and D) <i>Anomalocardia squamosa</i>	101
Figure 6-27 Mangrove horseshoe crab (<i>Carcinoscorpius rotundicauda</i>) recorded within Sungei Durian.	102
Figure 6-28 Sample coverage curves for each taxon for each survey method.	103
Figure 6-29 Impact zone for habitat and plant species receptors.....	110
Figure 7-1 Location of ADCP.	131
Figure 7-2 Location of water quality sampling points.	135
Figure 7-3 Location of sediment quality sampling points.....	137
Figure 7-4 Location of underwater noise monitoring point.	139
Figure 7-5 Elevation and bathymetry map of Project Site and its vicinity	149
Figure 7-6 Slope map of Project Site and its vicinity	150
Figure 7-7 Catchment map of Project Site and its vicinity	151
Figure 7-8 Overview of hydrodynamic study area.	152
Figure 7-9 Overview of bathymetry of Project Site and its vicinity (mMSL).	153
Figure 7-10 Typical spring flood tide currents in the vicinity of Project Site.	154
Figure 7-11 Typical spring ebb tide currents in the vicinity of Project Site.	154
Figure 7-12 Typical neap flood tide currents in the vicinity of Project Site.....	155
Figure 7-13 Typical neap ebb tide currents in the vicinity of Project Site.	155
Figure 7-14 Typical wave climate (significant wave height – h_{sig}) surrounding Pulau Ubin.	156
Figure 7-15 Simulated water depth in the vicinity of Project Site.....	156
Figure 7-16 Monitoring results of in-situ water quality parameters.	170
Figure 7-17 Monitoring results of ex-situ water quality parameters (1 of 3). Note: missing bars indicates that the concentration of the measured parameter is below the detection limit.	172
Figure 7-18 Monitoring results of ex-situ water quality parameters (2 of 3). Note: missing bars indicates that the concentration of the measured parameter is below the detection limit.	173
Figure 7-19 Monitoring results of ex-situ water quality parameters (3 of 3). Note: missing bars indicates that the concentration of the measured parameter is below the detection limit.	174
Figure 7-20 Spectrogram of first monitoring event. Segment labelled 'A' highlights the acoustic signature of turbulent pressure fluctuations of currents. Segment labelled 'B' indicates the period with decreased vessel traffic. The horizontal axis indicates time, left vertical axis indicates the frequency and the right vertical axis shows a colour scale of the 1/3-octave sound pressure level (SPL).	175
Figure 7-21 Spectrogram of second monitoring event. Segment labelled 'A' highlights the acoustic signature of turbulent pressure fluctuations of currents. Segment labelled 'B' indicates the period with decreased vessel traffic. The horizontal axis indicates time, left vertical axis indicates the frequency and the right vertical axis shows a colour scale of the 1/3-octave sound pressure level (SPL).	176
Figure 7-22 Density probability spectrogram for the first monitoring period at the underwater noise monitoring location. The 1 st , 5 th , 25 th , 50 th , 95 th and 99 th percentiles and RMS levels were plotted. The 5 th percentile is the minimum, 50 th percentile is the median and 95 th the maximum. The colour scale represents the spectral probability density (SPD).....	177
Figure 7-23 Density probability spectrogram for the first monitoring period at the underwater noise monitoring location. The 1 st , 5 th , 25 th , 50 th , 95 th and 99 th percentiles and RMS levels are plotted. The 5 th percentile is the minimum, 50 th percentile is the median and 95 th the maximum. The colour scale represents the spectral probability density (SPD).....	177
Figure 7-24 Potential sensitive receptor locations within the Project Site and its vicinity during construction phase.	181

Figure 7-25 SSC spilling locations of sediment plume modelling scenarios.....	190
Figure 7-26 Typical maximum (95 th percentile) excess SSC levels predicted from filling activities at Pond 2 with minimum controls during a full tidal cycle of southwest monsoon (SW2C).	192
Figure 7-27 Typical maximum (95 th percentile) excess SSC levels predicted from filling activities at Pond 3 with minimum controls during a full tidal cycle of southwest monsoon (SW3C).	193
Figure 7-28 Typical mean excess sedimentation rate predicted from filling activities at Pond 2 with minimum controls during a full tidal cycle of southwest monsoon (SW2B).	194
Figure 7-29 Typical mean excess sedimentation rate predicted from filling activities at Pond 3 with minimum controls during a full tidal cycle of southwest monsoon (SW3C).	194
Figure 7-30 Maximum (95 th percentile) current speed in the vicinity of Project Site during one tidal cycle of without and with development phases.....	198
Figure 7-31 Difference in maximum (95 th percentile) current speed in the vicinity of Project Site during one tidal cycle between without and with development phases.	199
Figure 7-32 Difference in predicted bed levels after five (5) years at Sg Jelutong area between without and with development scenarios (note: positive values – increase in bed level compared to baseline condition; negative values – reduce in bed level compared to baseline condition).	201
Figure 7-33 Typical mean excess sedimentation rate predicted from filling activities at Pond 2 with mitigated measures during a full tidal cycle of southwest monsoon (SW2B).	204
Figure 7-34 Typical mean excess sedimentation rate predicted from filling activities at Pond 3 with mitigated measures during a full tidal cycle of southwest monsoon (SW3C).	204
Figure 8-1 Project organization and lines of communication during the construction phase.	210
Figure 8-2 Project organization and lines of communication during the operational phase.	210
Figure 8-3 Monitoring of vegetation and trees along the hoarding line for unauthorised vegetation clearance and forest edge effects.....	217
Figure 8-4 Photographs showing monthly fauna monitoring and inspection on-site	221
Figure 8-5 Example of pre-felling inspection protocol	222
Figure 8-6 Example of one-way flap door to allow fauna to exit independently.	223
Figure 8-7 A flow chart of wildlife response plan.	223
Figure 8-8: Proposed water quality monitoring locations during construction and operational phases.	227

Tables

Table 1-1 Summary of key mitigation measures and best management practices.....	18
Table 1-2 Summary of impact significance for construction and operational phases (range if applicable).....	19
Table 3-1 Volume of fill used and mangrove area generated in Pond 2 and Pond 3.....	32
Table 3-2 Species of mangroves potentially recruited [P-35].....	33
Table 3-3 Construction timeline of major developments in the vicinity of Project Site.....	46
Table 4-1 Relevant regulatory framework, international standards and guidelines.....	49
Table 5-1 Study Area for different environmental parameters.....	54
Table 5-2 Receptor sensitivity classification.....	55
Table 5-3 Site visits for data collection.....	58
Table 5-4 Methodology for prediction of construction impacts.....	59
Table 5-5 Methodology for prediction of operational impacts.....	60
Table 5-6 Evaluation of impact intensity for construction phase.....	62
Table 5-7 Evaluation of impact intensity for operational phase.....	63
Table 5-8 Impact consequence matrix.....	64
Table 5-9 Likelihood criteria.....	64
Table 5-10 Impact significance matrix.....	65
Table 6-1 Key references for the nomenclature and taxonomy for each taxonomic group.....	67
Table 6-2 Summary of flora and faunistic surveys.....	70
Table 6-3 Area occupied by the various vegetation types.....	77
Table 6-4 Total number of plant species recorded in the Study Area summarised by their native and national status.....	84
Table 6-5 All Conservation Significant fauna species found at Sungei Durian.....	90
Table 6-6 Result summary of camera trap data.....	97
Table 6-7 Result summary of taxon sampling analysis table.....	102
Table 6-8 Criteria for assessing the ecological value of habitats.....	104
Table 6-9 Criteria for assessing the ecological value of plant species.....	105
Table 6-10 Summary of ecological value of habitats recorded with Study Area.....	107
Table 6-11 List of potential ecological impacts during construction and operational phases.....	108
Table 6-12 Description of minimum controls implemented at construction and operational phases.....	111
Table 6-13 Definitions of each level of impact intensity for habitat receptors during construction.....	113
Table 6-14 Definitions of each level of likelihood for habitat receptors during construction.....	113
Table 6-15 Definitions of each level of impact intensity for flora receptors during construction.....	113
Table 6-16 Definitions of each level of likelihood for flora receptors during construction.....	114
Table 6-17 Definitions of each level of impact intensity for faunal receptors during construction.....	114
Table 6-18 Definitions of each level of likelihood for faunal receptors during construction.....	115
Table 6-19 Summary of construction phase impacts to habitat receptors during construction phase.....	116
Table 6-20 Summary of construction phase impacts to flora receptors during construction phase.....	117
Table 6-21 Summary of construction phase impacts to fauna receptors.....	117
Table 6-22 Summary of impact evaluation on habitats, flora and fauna receptors.....	118
Table 6-23 Definitions of each level of impact intensity for habitat receptors at the operational phase.....	119
Table 6-24 Definitions of each level of likelihood for habitat receptors at the operational phase.....	119
Table 6-25 Definitions of each level of impact intensity for faunal receptors at the operational phase.....	120
Table 6-26 Definitions of each level of likelihood for faunal receptors at the operational phase.....	120
Table 6-27 Summary of operational phase impacts to faunal receptors.....	121
Table 6-28 Summary of impact evaluation on habitats, flora and fauna receptors.....	122
Table 6-29 Key recommended measures to minimise biodiversity impacts during the construction phase.....	123
Table 6-30 Summary of construction phase residual impacts to faunal receptors.....	125
Table 6-31 Summary of impact evaluation on habitats, flora and fauna receptors.....	126
Table 6-32 Summary of operational phase residual impacts to faunal receptors.....	127
Table 6-33 Summary of impact evaluation on habitats, flora and fauna receptors.....	127
Table 7-1 Rationale for the selected water quality sampling locations with photos.....	132
Table 7-2 Rationale for the selected sediment quality sampling locations.....	136
Table 7-3 Rationale for the selected underwater noise monitoring location.....	138
Table 7-4 Water quality guidelines and criteria.....	140
Table 7-5 Guideline values (in mg/kg) for sediment quality.....	142
Table 7-6 Recommended underwater noise criteria for marine mammal from literature review [P-82].....	143
Table 7-7 Recommended underwater noise criteria for fish due to impulsive sound from literature review [R-31].....	143

Table 7-8 Recommended underwater noise criteria for fish due to continuous sound from literature review [R-31].	144
Table 7-9 Potential marine water impacts during the construction phase.....	146
Table 7-10 Potential hydrology and water quality impacts during the operational phase.	147
Table 7-11 Particle size distribution (in %) of the sediment at survey locations.....	157
Table 7-12 Sediment quality at each sediment sampling location at Project Site.....	159
Table 7-13 Sediment quality sampling locations at Noordin Beach and Mamam Beach.	161
Table 7-14 Sediment quality at each proposed fill material source site.	162
Table 7-15 Water quality monitoring schedule.....	164
Table 7-16 Water quality results	165
Table 7-17 Classification of marine water sensitive receptors identified within the Assessment Area for construction phase.....	178
Table 7-18 Classification of marine water sensitive receptors identified within the Assessment Area for operational phase	182
Table 7-19 Minimum controls during the construction phase applicable to marine water quality impact assessment	183
Table 7-20 Minimum controls during the operational phase applicable for marine water quality impact assessment	187
Table 7-21 Sediment plume modelling scenarios.	190
Table 7-22 Marine water quality impact assessment criteria on excess SSC.....	191
Table 7-23 Marine water quality impact assessment criteria on mean sedimentation rate.....	191
Table 7-24 Predicted construction activities induced excess SSC with minimum control at water quality receptors during both southwest (SW) and northeast (NE) monsoon seasons.....	192
Table 7-25 Predicted construction activities induced mean excess sedimentation rates with minimal control at water quality receptors during both southwest (SW) and northeast (NE) monsoon seasons.	193
Table 7-26 Summary of impact evaluation on water quality and socio-economic receptors.....	196
Table 7-27 Summary of impact evaluation on hydrodynamics.	199
Table 7-28 Summary of impact evaluation on water quality and socio-economic receptors.....	200
Table 7-29 Summary of impact evaluation on morphology.	202
Table 7-30 Predicted construction activities induced mean excess sedimentation rates with mitigation measures (double layers of silt curtains) at water quality receptors during both southwest (SW) and northeast (NE) monsoon seasons.....	203
Table 7-31 Summary of residual impacts and its mitigation measures.....	205
Table 7-32 Summary of marine water impact assessment.	207
Table 8-1 Minimum root ball diameter to girth requirements	220
Table 8-2 Recommended standards and guidelines for water quality monitoring.	225
Table 8-3 Recommended water quality specifications and parameters during construction phase.....	225
Table 8-4 Recommended water quality specifications and parameters during operational phase.	228
Table 8-5 Proposed environmental monitoring and management plan for the construction phase.	231
Table 8-6 Proposed environmental monitoring and management plan for the operational phase.....	236
Table 10-1 Summary of impact significance for construction and operational phases	238

Appendices

Appendix A.	Flora Species List
Appendix B.	True Mangrove Species List
Appendix C.	Locations of Plants of Conservation Significance
Appendix D.	Locations and Size Data of Significant Large Trees
Appendix E.	List Of Recorded Faunal Species And Probable Species
Appendix F.	Fauna Survey Data
Appendix G.	Camera Trap Data
Appendix H.	Impact Assessment on Habitat, Plants and Fauna Receptors
Appendix I.	Tree Protection and Conservation Guidelines
Appendix J.	Fauna Inspection Form
Appendix K.	Pre-felling Inspection Form
Appendix L.	Wildlife Incident Form
Appendix M.	Marine Water Impact Assessment Criteria
Appendix N.	Marine Water Model Setup and Calibration
Appendix O.	Marine Water Model Results
Appendix P.	Baseline Water Quality Reports and Sediment Reports
Appendix Q.	Sediment Quality Reports from Northern Pulau Ubin Project
Appendix R.	Survey Report for Acoustic Doppler Current Profiler (ADCP) Wave Measurements
Appendix S.	Survey Report for Underwater Noise Monitoring Data

List of Acronyms

Acronym	Definition
AECOM	AECOM Singapore Pte. Ltd.
ALARP	As Low As Reasonably Practicable
ASM	Approved Soil Mixes
BIA	Biodiversity Impact Assessment
CCTV	Closed-circuit television
CMS	Conservation of Migratory Species
COPPC	SS 593: Code of Practice for Pollution Control, 2013
DGPS	Differential Global Positioning System
DO	Dissolved Oxygen
ECM	Earth Control Measures
EIA	Environmental Impact Assessment
FUN	Friends of Ubin Network
GIS	Geographic Information System
GPS	Global Positioning System
HASP	Health and Safety Plan
HK EIAO TM	Hong Kong Environmental Impact Assessment Ordinance – Technical Memorandum
IUCN	International Union for Conservation of Nature
mCD	Metre Chart Datum
mSHD	Metre Singapore Height Datum
MLS	Marchwood Laboratory Services Pte Ltd
NAS	National Archives of Singapore
NBSAP	National Biodiversity Strategy and Action Plan
NEA	National Environment Agency
NG	Nature Group
NParks	National Parks Board
NUS	National University of Singapore
NUSLHMSG	NUS Libraries Historical Maps of Singapore
PUB	Public Utilities Board
R.U.M.	Restore Ubin Mangroves
SIDS	Silty Imagery Detection System
SLA	Singapore Land Authority
SRDB	Singapore Red Data Book
TDS	Total dissolved solids
TN	Total Nitrogen
TP	Total Phosphorus
TSS	Total Suspended Solids
URA	Urban Redevelopment Authority
USEPA	United States Environmental Protection Agency

List of Glossary

Term	Definition	References for Definition
Casual	Exotic species that do not form self-replacing populations and rely on repeated introductions or limited asexual reproduction for persistence	Chong et al., 2009 [P-5]; Pyšek et al., 2004 [P-21]
Common	(Flora) Native species that have more than 1000 mature individuals locally	Chong et al. [P-5], 2009; SRDB [P-8]
Critically Endangered	Species facing an extremely high risk of extinction in the wild/in Singapore (with <50 mature individuals or <250 total individuals)	SRDB [P-8]; IUCN [R-7]
Cryptogenic	Plant of uncertain origin. Species without biogeographical or historical evidence of being non-native, but are restricted to only human-modified or human disturbed habitats	Chong et al., 2009 [P-5]; Pyšek et al., 2004 [P-21]
Cultivated Only	(Flora) Exotic species that persist locally as a result of cultivation or other direct human care	Chong et al., 2009 [P-5]; Pyšek et al., 2004 [P-21]
Endangered	Species facing a very high risk of extinction in the wild/in Singapore (with <250 mature individuals)	SRDB [P-8]; IUCN [R-7]
Exotic	Species whose presence is a result of either intentional or unintentional human involvement	Chong et al., 2009 [P-5]; Pyšek et al., 2004 [P-21]
Native	Species that have originated in a given area without human involvement or have arrived there without intentional or unintentional intervention of humans from an area in which they are native	Chong et al., 2009 [P-5]; Pyšek et al., 2004 [P-21]
Naturalised	Exotic species that form self-replacing, usually sexually reproducing populations	Chong et al., 2009 [P-5]; Pyšek et al., 2004 [P-21]
Managed Vegetation	(Flora) Area consisting vegetation that are actively managed, i.e. pruned regularly. It is now the most common type of vegetation in Singapore, owing to a government commitment to plant up the landscapes surrounding residential, industrial and commercial areas	Yee et al. 2019 [P-33]
Presumed Nationally Extinct (NE)	(Flora) Species that has not been recorded within Singapore for the last 30 years	SRDB [P-8]
	(Fauna) Species that has not been recorded within Singapore for the last 50 years	SRDB [P-8]
Probable	A list of faunal species that are likely to occur at the site (termed thereafter in the report as “species of probable occurrence”)	-
Rarity	This definition differs for each faunal taxon. The rarity for each taxa are reference to those listed in Singapore Red Data Book (SRDB), and other more updated local checklists, where available, such as Soh et al. 2019 for odonates and Jain et al. 2018 for butterflies. The global conservation status references the Red List of Threatened Species by the International Union for Conservation of Nature (IUCN, 2021).	SRDB [P-8]; Soh et al. 2019 [P-24]; Jain et al. 2018 [P-11]; IUCN [R-7]
Threatened	(Flora) Flora species that were listed as nationally Vulnerable, Endangered, Critically Endangered, or Presumed Extinct (which indicates a rediscovery)	SRDB [P-8]
	(Fauna) Threatened species of fauna are those listed as nationally or globally Vulnerable, Endangered, Critically Endangered, or Extinct	SRDB [P-8]
Uncommon	This definition differs for each faunal taxon. The rarity for each taxa are reference to those listed in Singapore Red Data Book (SRDB), and other more updated local checklists, such as Soh et al. 2019 for odonates and Jain et al. 2018 for butterflies. The global conservation status references the Red List of Threatened Species by the International Union for Conservation of Nature (IUCN, 2021).	SRDB [P-8]; Soh et al. 2019 [P-24]; Jain et al. 2018 [P-11]; IUCN [R-7]

1 Executive Summary

AECOM Singapore Pte Ltd was appointed by National Parks Board (NParks) to carry out *Consultancy Services for Mangrove Restoration of Sungei Durian Ponds Environmental Impact Assessment (EIA)* (hereinafter referred to as 'the Project'), which is one of the nature-based coastal protection projects proposed by NParks in efforts to strengthen Singapore's coastal resilience. The Sungei Durian Ponds consist of three abandoned prawn ponds which are located on the southeast of Pulau Ubin, an offshore island of Singapore. These three ponds have a total area of approximately 5.76 hectares (ha) (hereafter collectively referred to as 'Project Site'). This Project Site was formerly a mangrove forest which was cleared for prawn farming activities. While the aquaculture activities have since ceased and the ponds were abandoned in early 2000s, natural regeneration of the mangroves is still not occurring at these ponds, except along the edges of the bunds of these Ponds. This is because the substrate elevation was assessed to be too low in the ponds and too high on the bunds for the natural establishment of mangroves and propagation of their saplings. Hence, the backfilling works has been proposed in Pond 2 and Pond 3 for mangrove restoration (Figure 1-1), as part of the Ecological Mangrove Restoration (EMR) method. Rather than to transplant mangrove saplings, this EMR method involves the identification and re-establishment of suitable physical environmental conditions within the Project Site for mangrove forests, which will subsequently allow the natural regrowth of mangroves forests. Dredged material generated from the other natural-based solution proposed by NParks, which is the shoreline protection project at Northern Pulau Ubin, will be transported to this Project Site, to restore the elevations in the Project Site to levels that are suitable for the natural propagation of mangroves. It should be noted that filling works will not be conducted in Pond 1.

With the current proposed developments within the Project Site, there is a need to: (1) understand the baseline ecological and environmental conditions of the Site; (2) assess potential impacts on the local biodiversity and environment associated with and/or caused by the Project during both construction and operational phases; (3) recommend mitigation measures to safeguard the existing ecological and avian connectivity, and incorporate them into the future development; and (4) to develop an Environmental Monitoring and Management Plan (EMMP).

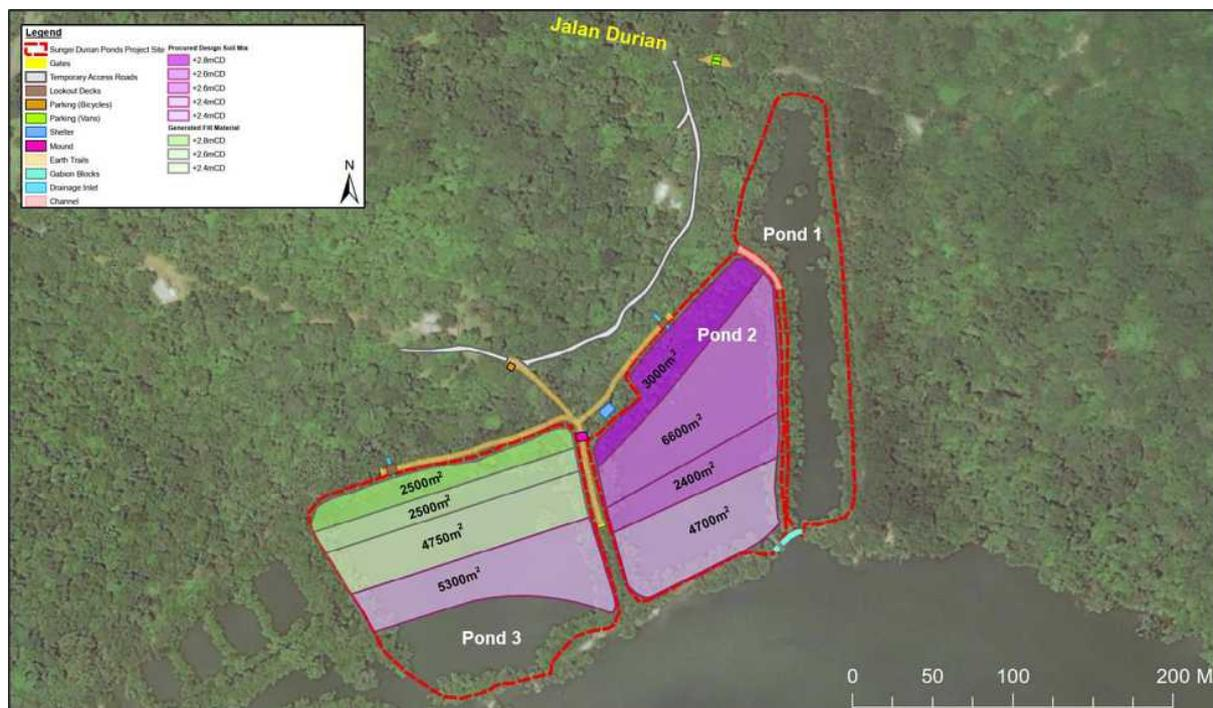

Figure 1-1 Prospective development plan in the Project Site.

Environmental Baseline Findings

Baseline studies on biodiversity, hydrodynamics, water quality, sediment quality, and underwater noise were conducted in the vicinity of the Project Site, and a summary of the findings is provided below. More information can be obtained from Sections 6 and 7 of the report, respectively.

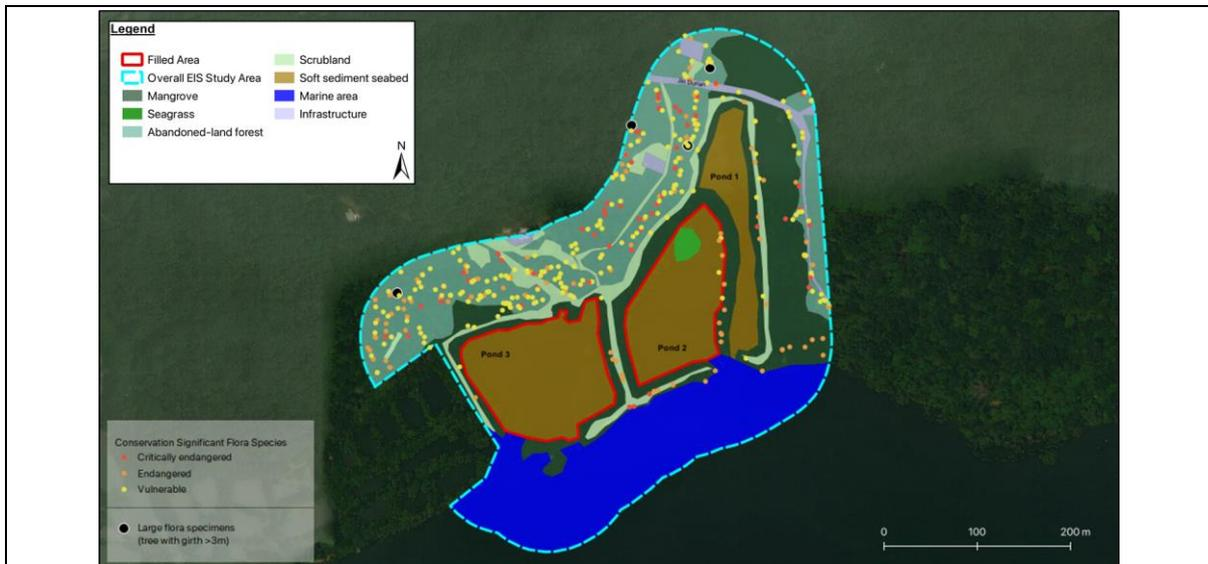

Figure 1-2 Distribution of habitats, vegetation and flora species of conservation significance within Study Area.



Figure 1-3 Locations of faunal species of conservation significance, including camera trap records.

- Habitats and Vegetation Distribution** (see Figure 1-2) – Study Area consists of six (6) different terrestrial and marine habitats, and vegetation types. Majority of the site consists of terrestrial habitats, which include abandoned-land forest (3.88 ha; 24.33%), mangrove forest (3.60 ha; 22.52%) and scrubland and herbaceous vegetation (1.17 ha; 7.35%). Infrastructure was sporadically distributed within the terrestrial habitat and consist of 0.33 ha (2.07%), which are all man-made. Marine habitats consist of soft sediment seabed (3.70 ha; 23.13%) and marine area (3.29 ha; 20.60%). There is a small, scattered patch of spoon seagrass (*Halophila ovalis*) within the soft sediment seabed habitat distributed within an area of 0.078ha.
- Biodiversity, Flora, Large Plant Specimens and Other Specimens of Value** (see Figure 1-2) – 195 species of plants were recorded. Of which 52 plant species are of conservation significance. Four (4) large plant specimens (trees with girth >3m) were recorded, with the all of these specimens found within the abandoned-land forest. Such large specimens can provide valuable habitats and food sources to fauna.
- Biodiversity, Fauna** (see Figure 1-3) – A total of 285 species were recorded, where 157 are marine species and 128 were terrestrial species. 128 terrestrial faunal species recorded consists of 16 odonates, 29

butterflies, four amphibians, seven reptiles, 58 birds and 14 mammals — of which 17 species are of conservation significance. 157 aquatic faunal species recorded consist of 23 fish, 26 decapod crustaceans, 107 molluscs and one (1) xiphosurid — of which three (3) species are of conservation significance.

- **Hydrodynamic Conditions** – The annual hydrodynamic conditions in the vicinity of Project Site are characterised by the two monsoon seasons, namely, the Southwest (SW) Monsoon occurring from June to September while the Northeast (NE) Monsoon occurring from December to early March. The hydrodynamic currents of Singapore are dominated by semi-diurnal pattern. In the vicinity of Project Site, currents flow in and out of the pond areas along with the tide cycles with a tidal range of around 3.4m in the offshore area. During both NE and SW Monsoon seasons, especially at the pond opening areas, the current could reach up to 0.79 m/s during spring tide, while up to 0.56 m/s during neap tide.
- **Water Quality** – Six (6) water quality sampling stations were identified, which are located at the back mangrove area at the east of Project Site, at each of the three Sg. Durian Ponds, at the coastal area just south of the Project Site and at an offshore area near the aquaculture farms. Generally, the baseline water quality across all sampling stations were favourable for aquatic life, with minimal variation in water quality across the stations. Dissolved Oxygen (DO) was found to be below the recommended levels as stated in the ASEAN marine water quality guidelines for aquatic life (AMWQC) at the back mangrove area but was likely attributed to the local stagnant site conditions and aquatic fauna was not observed at time of survey. High nutrient levels were measured across all sampling stations, which is consistent with previous research studies of the Serangoon Harbour [P-76, P-77]. Presence of other chemical compounds, such as all measured heavy metals and biochemical oxygen demand (BOD₅), were found to be well below their respective threshold limits. However, tributyltin was found to exceed the AMWQC limits at all stations, and the source was likely from the marine environment. Biological pollutants (i.e. *enterococcus* and faecal coliform) was found to exceed the AMWQC for human health protection at sampling stations that were located at proximity to the Project Site (i.e. excludes the offshore sampling station), which implies that it was likely contributed from animal faecal matter in the terrestrial environment. This may imply that the baseline water quality may pose human health risks if primary contact activities be conducted within the waters.
- **Sediment Quality and Particle Size Distribution** – Eight (8) sediment samples were collected from the Project Site and its surroundings – including the nearby back mangrove area, from both the back mangrove area, near the bunds and middle of each Pond and the coastal area just south of the Project Site. The sediment quality mostly met MPA General Guidelines on the Requirements for Application on Dredging and Dumping Works, with only a slight exceedance in arsenic concentrations at the back mangrove area. This was attributed to the characteristics of mangrove soils to uptake and accumulate arsenic. The baseline sediment quality established that any future contamination identified within the Project Site is unlikely to originate from the existing sediments. Generally, the sediments from the middle of each Pond had a higher composition of fine sediments. The sediments collected near the bunds generally had relatively equal sand and silt composition, while the coastal area had a high proportion of sand.
- **Underwater Noise** – Underwater noise monitoring was conducted at one (1) offshore location along Serangoon Harbour in the vicinity of the Project Site. The ambient background noise levels at Serangoon Harbour which are within the hearing sensitivities of fishes (i.e. 30 Hz to 5 kHz [P-80]) range between 70 – 110 dB (5th to 95th percentiles). Generally, the baseline ambient underwater noise environment is well below the threshold value of 158 dB re 1 µPa of impairment to fishes (refer to Table 7-8). Background levels within the hearing sensitivities of dugongs (i.e. 1 kHz to 18 kHz [P-81]) – known to be found along the East Johor Strait (refer to Appendix E) – ranges between 90 to 110 dB (5th to 95th percentiles). Currently, little is known about the threshold for detectable auditory responses by dugongs. For cetaceans like Irrawaddy dolphin (*Orcaella brevirostris*), Indo-pacific humpbacked dolphin (*Sousa chinensis*), Indo-pacific bottlenose dolphin (*Tursiops aduncus*)– refer to Appendix E for expected species list near the site, the baseline sound pressure level is within 90 – 105 dB (5th to 95th percentiles) of their hearing range of 150 Hz to 160 kHz [P-82], which is well below the onset threshold of 120 dB root mean square (RMS) for continuous noises (refer to Table 7-6).

Impact Assessment Methodology

Sections 6 and 7 of the EIA report discuss the methodologies used for impact identification, prediction and assessment on environmental parameters including biodiversity, hydrodynamics, water quality (including sediment plume), marine morphology, and underwater noise during the construction and operational phases of the development.

Key Mitigation Measures

Table 1-1 summarises the key mitigation measures that have been developed to minimise the adverse impacts throughout the course of the Project. More details can be found in Sections 6 and 7 of the report.

Table 1-1 Summary of key mitigation measures and best management practices

Environmental Parameter	Recommended Key Mitigation Measures and Best Management Practices	
	During Pre-construction & Construction Phase	During Operational Phase
<p>Biodiversity</p> <p>(both construction and operational phases)</p>	<ul style="list-style-type: none"> • Conduct regular inspections to ensure contractor compliance to the EMMP, with oversight by NParks; • Conduct directional site clearance and phased hoarding installation for passive wildlife shepherding; • Ensure terrestrial worksite hoarding are installed 300mm into the ground to prevent wild boars from digging beneath the hoarding; • Ensure silt fences and other silt control measures along the worksite hoarding are installed and maintained properly; • Conduct monitoring to identify any impacts to habitats adjacent to the worksite; • Ensure there are no works and disturbances to areas outside of worksite and restrict entry of site personnel to areas outside the worksite; • Engage flora specialists to clearly mark out areas and plants with conservation value before the start of works. This would avoid clearing unnecessary working space, eliminate the need of removing plants of conservation significance as much as possible— <i>Lumnitzera racemosa</i>, <i>Ceriops zippeliana</i>, <i>Lumnitzera littorea</i> and <i>Ceriops tagal</i>; • Engage flora specialists to assess if affected species can be harvest/transplanted before the start of works; • It is recommended to avoid tree felling and vegetation clearance during peak bird breeding season (March to July); • Pre-felling fauna inspection should be conducted before felling any trees or removing any vegetation. This should be planned and overseen by an Ecologist; • Quieter construction machinery/equipment should be used over loud and noisy machinery/equipment whenever possible; • Night-time works should be avoided to prevent disturbance to nocturnal fauna; recommended to restrict working hours to 0800–1800; • Establish a Wildlife Response Plan in consultation with NParks Animal Management Centre and NParks Ubin Management, to be executed during encounters with trapped, injured or dead wildlife, as well as incidents of human-wildlife conflict; • Train site personnel on biodiversity awareness and actions to take when encountering wildlife; and • Ensure good housekeeping controls such as provision of wildlife-proof bins and eating areas to prevent macaques from accessing anthropogenic food sources. 	N.A.
<p>Water Quality</p> <p>(both construction and operational phases)</p> <p>Sediment Plume</p> <p>(construction phase only)</p>	<ul style="list-style-type: none"> • To use Cage Type Grab Dredger; and • To install double layers of silt curtains surrounding the working areas when pond filling activities are carried out. 	N.A.
<p>Underwater Noise</p> <p>(construction phase only)</p>	<ul style="list-style-type: none"> • Switch off the boat engine when transferring the fill materials from the flattop barge onto the modular barge. 	-

Recommended Key Mitigation Measures and Best Management Practices		
Environmental Parameter	During Pre-construction & Construction Phase	During Operational Phase
Hydrodynamics (operational phase only)	-	N.A.
Morphology (operational phase only)	-	N.A.
Note:		
1. N.A. – as the negative impact significance is below moderate, no mitigation measures are required.		
2. '-' – as the environmental parameter was not assessed for the specified construction/operational phase.		

Summary of Impact Assessment

With the implementation of mitigation measures, the overview of impact evaluation for both construction and operational phases are summarised in Table 1-2.

Despite the major biodiversity impacts after mitigation, it is important to note that in a long run, the positive impact of a restored mangrove habitat will outweigh the negative impacts of losing a lower-valued soft-sediment seabed. Ecological mangrove restoration (EMR) encourages the natural establishment of mangrove with prior understanding of site conditions and is superior to mangrove sapling planting, which is prone to failure and limited biodiversity [W-25]. However, this method will involve a longer period of recovery as site conditions are being reconstructed to favourable tidal inundation and substrate levels by improving the local hydrology and promoting sediment accretion.

Given the nature of EMR, short-term loss and degradation of habitats, limited decline in flora health and fauna mortality are to be expected during the construction phase. However, with the creation of a high-value mangrove habitat in place of the extent soft-sediment seabed, overall net gain in biomass and diversity is expected to surpass the current state at the point of project completion in the operational phase.

Table 1-2 Summary of impact significance for construction and operational phases (range if applicable).

Environmental Parameter	Sensitive Receptor	Impact Significance with Minimum Control	Impact Significance After Implementation of Mitigation Measures (if required)
Construction phase			
Biodiversity	Ecological habitats in the vicinity of Project Site	Negligible to Major Negative	Negligible to Major Negative
Marine Water Quality (excluding sediment plume)	On-site construction workers	Negligible Negative	N.A.
	Off-site residents and visitors (recreational facilities including Serangoon Harbour, jetties, Jelutong Campsite, etc.)	Negligible Negative	N.A.
	Habitats and biocenosis in the vicinity of Project Site	Negligible Negative	N.A.
	International Boundary (IB)	Negligible Negative*	N.A.

Environmental Parameter	Sensitive Receptor	Impact Significance with Minimum Control	Impact Significance After Implementation of Mitigation Measures (if required)
Sediment Plume	Off-site residents and visitors (recreational facilities including Serangoon Harbour, jetties, Jelutong Campsite, etc.)	Minor Negative	N.A.
	Seagrass (including Chek Jawa)	Minor Negative	N.A.
	Mangrove along the southern shoreline of Pulau Ubin	Minor to Major Negative	Negligible to Minor Negative
	Aquaculture farms	Negligible Negative	N.A.
	International Boundary (IB)	Negligible Negative*	N.A.
Underwater Noise	Habitats and biocenosis in the vicinity of Project Site	Minor Negative	Negligible Negative
	Aquaculture farms	Minor Negative	Negligible Negative
Operational Phase			
Biodiversity	Ecological habitats in the vicinity of Project Site	Negligible to Moderate Negative	Minor Negative to Positive
Marine Water Quality	Off-site residents and visitors	Negligible Negative to Positive	N.A.
	Habitats and biocenosis in the vicinity of Project Site	Negligible Negative to Positive	N.A.
	International Boundary (IB)	Negligible Negative* to Positive	N.A.
Hydrodynamic	Navigation channel near the southern coast of Pulau Ubin (i.e. Serangoon Harbour)	Negligible Negative	N.A.
	International Boundary (IB)	Negligible Negative*	N.A.
Morphology	Habitats and biocenosis in the vicinity of Project Site	Negligible Negative to Positive	N.A.
	International Boundary (IB)	Negligible Negative*	N.A.
<p>Note:</p> <p>* – As per Table 5-6 and Table 5-7, 'Negligible Negative' is equivalent to 'No expected changes / No contamination or likely to be well within regulatory limits / No detectable change'. Hence, there are no transboundary impacts.</p> <p>N.A. – as the negative impact significance is below moderate, no mitigation measures are required and no residual impact was assessed.</p>			

A set of Environmental Monitoring and Management Plan (EMMP) has also been developed for each environmental parameter, which will be updated and implemented during construction and operational phases, to ensure the effectiveness of the proposed mitigation measures. The EMMP is described in Section 8 of the EIA report.

2 Introduction

AECOM Singapore Pte Ltd was appointed by National Parks Board (NParks) to carry out *Consultancy Services for Mangrove Restoration of Sungei Durian Ponds Environmental Impact Assessment (EIA)* (hereinafter referred to as 'the Project'), which is one of the nature-based coastal protection projects proposed by NParks in efforts to strengthen Singapore's coastal resilience. The Sungei (Sg.) Durian Ponds consist of three abandoned prawn ponds which are located on the southeast of Pulau Ubin, an offshore island of Singapore. These three ponds have a total area of approximately 5.76 hectares (ha) (hereafter collectively referred to as 'Project Site'). This Project Site was formerly a mangrove forest which was cleared for prawn farming activities. Although the aquaculture activities have since ceased and the ponds were abandoned in early 2000s, the mangroves are still not regenerating naturally within these ponds, and are mainly growing along the edges of the bunds of these Ponds. It was found that the reason for the slow natural regeneration of mangroves was due to the great difference in substrate elevation between the ponds and the bunds, therefore hindering the natural establishment of mangroves and propagation of their saplings. Hence, the backfilling works was proposed to develop slopes that gently slope downwards from the bunds to the ponds. This proposed earth filling works is known as one of the steps the Ecological Mangrove Restoration (EMR) method. Rather than to conduct mangrove restoration via the transplantation of mangrove saplings, this EMR method involves the identification and re-establishment of suitable physical environmental conditions within a Site for mangrove forests, which will subsequently allow the natural regrowth of mangroves forests. Dredged material generated from another concurrent nature-based solution project located at the north of Pulau Ubin, which focuses on shoreline restoration of the island, will be transported to the Project Site and used as fill material to restore the elevations in the Project Site to levels that are suitable for the natural propagation of mangroves.

The area surrounding the Project Site is known to have high ecological sensitivity. For example, the ecologically sensitive Chek Jawa Wetlands is located in the east of the Site and aquaculture farms and recreational beaches in the south. Hence, this EIA is required to be undertaken to establish existing environmental baseline conditions and to assess the potential environmental impacts arising from, and associated with, the construction and operational phases of this Project.

Findings of the environmental baseline studies as well as the predicted environmental impacts resulting from this Project have been included in this EIA Report. This section will serve as a brief introduction of this EIA Report in terms of the scope of EIA, report structure, EIA schedule as well as study limitations, assumptions and constraints.

2.1 Scope of Work

The overall objectives of this EIA are as follows:

- To understand the proposed Project development and its related activities (e.g. backfilling works, temporary storage of backfill material, transportation of backfill material by barge, improvement works for site hydrology, and improvement works for public access/ amenities) during its construction and operational phases.
- To identify and determine the baseline conditions of biodiversity, hydrodynamics, water quality, sediment quality, and underwater noise parameters through site survey and sampling.
- To carry out a desktop study to review the findings of all relevant literatures, related previous studies and available information regarding the baseline environmental status of the Project Site.
- To identify and describe the elements of the biodiversity, hydrodynamics, water quality (including sediment plume), morphology and underwater noise that are likely to be affected by the Project.
- To identify key sensitive receptors in the terrestrial and marine environment that are likely to be impacted by the Project.
- To identify, quantify and assess potential impacts and determine the significance of these impacts on sensitive receptors and other potentially affected uses, using both qualitative and quantitative (e.g. using modelling tools) methods.
- To propose and justify effective mitigation measures to minimise adverse impacts (e.g. pollution, environmental disturbance, and nuisance) during construction and operational phases of the Project.
- To identify, predict and evaluate the residual environmental impact (i.e. after practicable mitigation) expected to arise during construction and operation of the Project in relation to the sensitive receptors.

- To propose an Environmental Monitoring and Management Plan to guide the Project including to identify, assess and specify methods, measures and standards, to be included during construction phase of the Projects which are necessary to mitigate the residual environmental impacts and cumulative effects and reduce them to minimal levels. An EMMP plan should include the following parameters: biodiversity, hydrodynamics, water quality, sediment plume, morphological and underwater noise.
- To conduct stakeholder engagements to understand the potential environmental concerns of relevant Authorities and the public on the proposed design and to propose mitigation measures or rectifications to minimise the environmental impact.

2.2 Report Structure

In meeting the objectives of the Inception Report, the structure of the report is as follows:

- **Section 1 – Executive Summary** of the Project provides a summary of findings from the baseline study and EIA;
- **Section 2 – Introduction** of the Project provides the detailed scope, report structure, EIA schedule, study limitations, assumptions and constraints;
- **Section 3 – Project Description** outlining the location and background of the Project, historical and current land uses, Project plans, proposed construction and operational activities, as well as Project Schedule that are known at this stage of the Project;
- **Section 4** – Provides a list of applicable **Environmental Legislation, Policies, Standards, and Criteria** relevant to the Project;
- **Section 5 – EIA Approach and Methodology** provides the overview of the methodology used for the assessment;
- **Section 6 – Biodiversity** presents the methodology, baseline environment, sensitive receptors, potential sources of impacts, minimum controls and evaluation of impacts to biodiversity in the vicinity of Project Site, along with recommendations for mitigation measures;
- **Section 7 – Marine Water** presents the methodology, baseline environment, sensitive receptors, potential sources of impacts, minimum controls and evaluation of impacts to marine waters (i.e. hydrodynamics, morphology, water quality and underwater noise) in the vicinity of Project Site, along with recommendations for mitigation measures;
- **Section 8 – Environmental Monitoring and Management Program (EMMP)** details the organisational framework, stakeholder roles and responsibilities, monitoring program requirements and detailed EMMP;
- **Section 9 – Stakeholder Engagement** provides a summary of the stakeholder engagement throughout the EIA process as well as their recommendations for this EIA and Project; and
- **Section 10 – Conclusion** provides a conclusive summary of the EIA's outcomes.

2.3 EIA Schedule

This section will provide the overview of the schedule for this Project.

- The **Inception Report** was submitted to NParks & relevant Authorities on the **30 November 2021**.
- The **Baseline Survey Findings** were presented to NParks during bi-weekly progress meetings from **April to May 2022**.
- This **Draft Final Report** is being submitted to NParks & relevant Authorities on the **11 August 2022**.
- The **Final Report** will be submitted to NParks & relevant Authorities in **August 2023**.

2.4 Study Limitations, Assumptions and Constraints

This document has been prepared by AECOM Singapore Pte Ltd (“AECOM”) for sole use of our client (the “Client”) in accordance with generally accepted consultancy principles, and the terms of reference agreed between AECOM and the Client. Any information provided by third parties and referred to herein has not been checked or verified by

AECOM, unless otherwise expressly stated in the document. No third party may rely upon this document without the prior and express written agreement of AECOM. The information contained in this document originally produced by AECOM Singapore Pte. Ltd. ("AECOM") was produced solely for the use of the Client and was prepared to assist in the Consultancy Services for Mangrove Restoration of Sungei Durian Ponds Environmental Impact Assessment (EIA).

Neither AECOM nor its parent corporation, or its affiliates, (a) makes any warranty, expressed or implied, with respect to the use of any information or methods disclosed in this document or (b) assumes any liability with respect to the use of any information or methods disclosed in this document. Any recipient of this document, by their acceptance or use of this document, releases AECOM, its parent corporation, and its and their affiliates from any liability for direct, indirect, consequential or special loss or damage whether arising in contract, warranty, express or implied, tort or otherwise, and irrespective of fault, negligence and strict liability.

AECOM undertakes no duty to, nor accepts any responsibility to, any other party who may rely upon such information unless otherwise agreed or consented to by AECOM in writing (including, without limitation, in the form of a reliance letter) herein or in a separate document. Any party who is entitled to rely on this document may do so only on the document in its entirety and not on any excerpt or summary. Entitlement to rely upon this document is conditional upon the entitled party accepting full responsibility and not holding AECOM liable in any way for any impacts on its work product for the Consultancy Services for Mangrove Restoration of Sungei Durian Ponds Environmental Impact Assessment (EIA) arising from changes in "external" factors such as changes in government policy, in the pricing of goods and materials or changes in the owner's policy affecting the operation of the project.

This document may include "forward-looking statements". These statements relate to AECOM's expectations, beliefs, intentions or strategies regarding the future. These statements may be identified by the use of words like "anticipate," "believe," "estimate," "expect," "intend," "may," "plan," "project," "will," "should," "seek," and similar expressions. The forward-looking statements reflect AECOM's views and assumptions with respect to future events as of the date of this report and are subject to future economic conditions, and other risks and uncertainties. Actual and future results and trends could differ materially from those set forth in such statements due to various factors, including, without limitation, those discussed in this report. These factors are beyond AECOM's ability to control or predict. No section or element of this document produced by AECOM may be removed from this document, reproduced, electronically stored or transmitted in any form by parties other than those for whom the document has been prepared without the written permission of AECOM.

During this study, there were inherent limitations associated with data acquisition in flora surveys due to the variability of vegetation communities across a site and changes to the detectability and presence of species with time (i.e. inaccessible areas due to the nature of arduous terrain that might be present). Therefore, it may be possible that some flora species occurring within the Project Site, or perhaps not visibly present during the survey period, were not recorded. However, the surveys were considered to be comprehensive as survey routes were strategically planned to cover ecologically and geographically representative samples of the Project Site, and all plant species sighted were identified and recorded to the best of the team members' abilities. Project team members who carried out the survey and identified the species post-survey have prior experience in conducting such flora assessments in Singapore.

As for the fauna surveys, surveys may not detect all species as fauna are highly mobile, frequently cryptic and vary in presence and abundance within and between seasons. Species returned by the literature review are therefore considered to be potentially present in the site and were included in this EIA as well. Professionals who carried out the fauna surveys are experienced field biologists and are familiar with the local fauna.

Due to the above, the statements, conclusions and opinions contained in this report are approximations of the existing environmental conditions within the Project Site, based on available literature, expert observations and opinion at the time of reporting. Reliance on the report after the date of issuance as an accurate representation of current site conditions shall be at the user's sole risk.

All maps/charts in this report are purely illustrative and are to be used solely for the purpose of assessing the environmental impact of the proposed works, and not for any other purpose.

3 Project Description

The section includes a description of the proposed Project Site location, historical and current land use, Project background, prospective development plans, the construction and operational activities, as well as Project schedule with other major concurrent development.

3.1 Project Location

The Project Site is located in the southeast of Pulau Ubin as shown in Figure 3-1. The Site lies to the south of Jalan Durian, which is an earth trail leading to the Project Site. These ponds are located along the southern coast of Pulau Ubin and are heavily influenced by tidal conditions via the sluice gates and openings located at the southern corner of each pond. The ecologically sensitive site (i.e. Chek Jawa Wetlands) is in the east of this Project Site and five (5) aquaculture farms are located to the south of this Project Site.

The Project Site has an area of approximately 5.76 ha and comprises of three (3) abandoned prawn ponds. The ponds are individually denoted as Pond 1, Pond 2, and Pond 3.



Legend

Sungei Durian Ponds Project Site

Rev.	Date	By	Description	Chk'd	App'd
-	AUG 2022	CQA	EIA Report	NHT	JAG

Qualified Person Endorsement :
NA

NParks Endorsement : NA

Consultant :
AECOM

Project Title :
**CONTRACT NPARKS/N/39/2017
CONSULTANCY SERVICES FOR SHORELINE
WORKS IN PULAU UBIN
(MANGROVE RESTORATION OF
SUNGEI DURIAN PONDS)**

Designed CQA	Checked NHT	Approved JAG
Drawn CQA	Date AUG 2022	

Client:

Figure Title :
Location of Project Site

Figure No. : 3-1	Rev. -	Sheet 1 of 1
---------------------	-----------	-----------------

CAD File Name : NA

A3

3.2 Historical Land Use

Prior to the 19th century, the Project Site and its vicinity was primarily wetland and mangrove swamp areas. It was only in the 1880s where settlements began to arrive onto the island [W-17]. The 1943 map of Pulau Ubin is shown in Figure 3-2A. After Singapore's independence, Malay villages (or *Kampungs*) appeared on the island by 1969 (Figure 3-2B). These *kampungs* were primarily occupied by fishermen who fished in the rich coastal waters of Singapore for a living [W-17]. Closest to the Sg. Durian Ponds (at the time), was *Kampung Melayu* and *Kampung Sungei Durian* (Figure 3-2B).

In the 1958 Master Plan, Pulau Ubin was designated for "Mineral Workings" and "Fisheries Reserves" [W-16]. As Singapore continued to develop, this likely led to the development of prawn ponds in the area. Maps show the beginnings of the creations of prawn farms in the south-eastern corner of Pulau Ubin as early as 1983, with the three ponds in our Project Site and biodiversity Study Area fully formed by 1993 (Figure 3-2C).

After prawn farming activity in the site ceased, mangroves have since settled and formed along the bund walls of the prawn ponds, and Figure 3-2D shows the land use map of the Project Site in 2005 that is similar to what can be observed from satellite images today (refer to Figure 3-1).

Based on satellite images of the Project Site in 2008, scouring was visible near the southern corners of each pond which was gradually eroding the bund walls. Over the years, the continuous erosion by wave action had eventually led to the breakthrough of the bund wall, therefore creating openings, at two locations in Pond 3 as observed in 2012 and 2015, and at one location each at Pond 1 in 2017 and at Pond 2 in 2019.

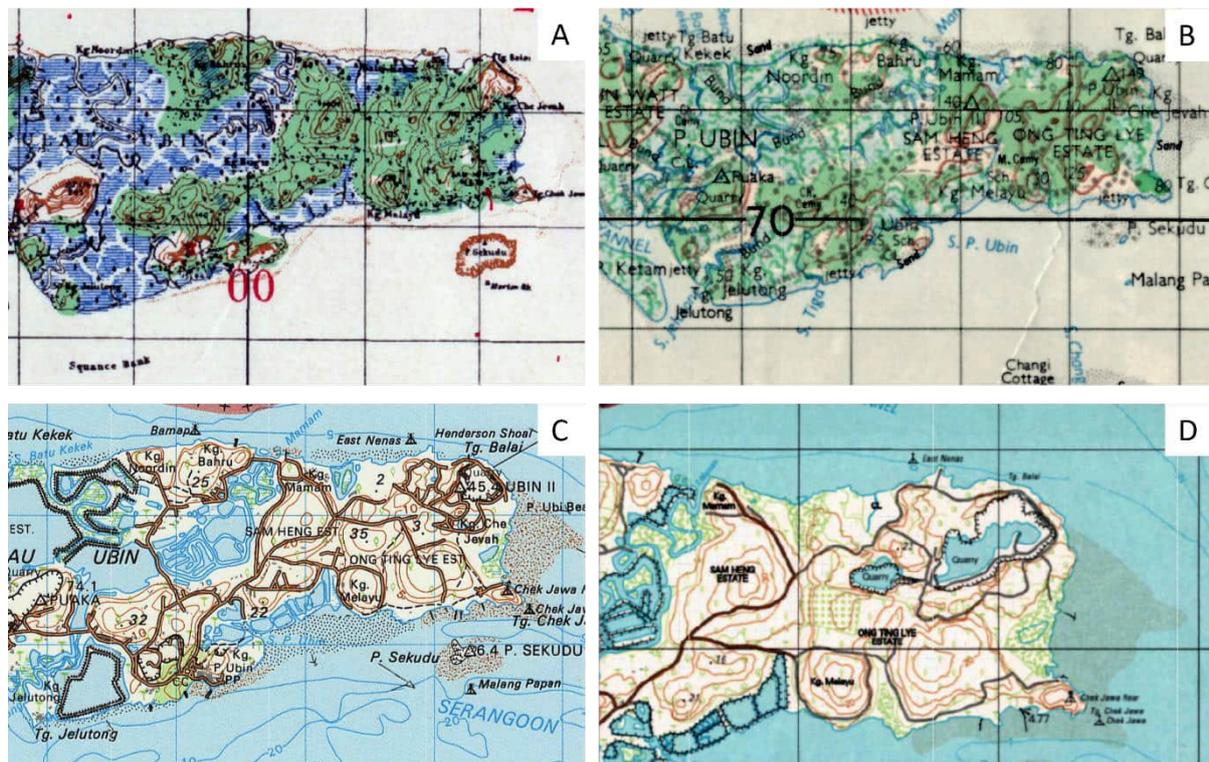

Figure 3-2 Maps showing the historical land use of the Project Site and its vicinity in (A) 1943, (B) 1969, (C) 1993 and (D) 2005 [M-2].

3.3 Current Land Use

Presently, the Project Site consists of three ponds, which each have man-made bunds constructed along its perimeters. Bathymetry maps of the ponds shows that the pond depth is relatively even throughout the Site, with an average elevation of -0.4 metres Singapore Height Datum (mSHD). These Ponds are connected to Serangoon Harbour and are heavily influenced by tidal conditions, due to the openings at the southern edges of each Pond. The water levels are approximately +1.18 mSHD during high tide and the Ponds are completely dry during low tide (see Figure 3-3A). Pond 2 and Pond 3 are largely barren (Figure 3-3A), while there are a few mangrove trees observed to be growing within Pond 1 (Figure 3-3B). On the other hand, majority of the mangroves have naturally established along the bunds as shown in Figure 3-3C.

Concrete structures, such as sluice gates and concrete platforms, are located near the south of Pond 1 and Pond 2 (see Figure 3-3D), which were likely constructed when the Ponds were used for prawn farming. The erosion of the bunds was observed to be especially severe near the pond openings near the southern edges of the Ponds, due to its proximity and interactions with the local coastal hydrodynamic conditions (see Figure 3-3E and Figure 3-3F).



Figure 3-3 Photos of existing site conditions (A) Pond 3 at low tide, (B) Mangroves growing within Pond 1, (C) Mangroves growing along the bunds between Pond 1 and Pond 2, (D) Broken sluice gate at south of Pond 1, (E) Severe erosion of bunds near the opening of Pond 3, and (F) An opening formed between two sluice gates at the south of Pond 1 and Pond 2.

3.4 Project Background

The Project Site was formerly a mangrove but was cleared to make way for prawn farming. While the aquaculture activities have since ceased and the ponds were abandoned in early 2000s, the natural regeneration of mangrove was still not occurring in these ponds, and are only growing along the edges of the bunds.

The Restore Ubin Mangroves (R.U.M.) initiative was conceived in 2014 by the Friends of Ubin Network (FUN), to restore mangroves on the island. This ground-up initiative brought together experts and volunteers from public organisations in Singapore to raise awareness on the importance of mangroves on Pulau Ubin and to conduct research on rehabilitating them [W-18].

Afterwards NParks commissioned a Research Collaboration Agreement with the Department of Geography of National University of Singapore (NUS), who conducted a study from 2016 to 2017 under the Restore Ubin Mangroves (R.U.M.) initiative [P-35]. Through this feasibility study, it was found that the absence of natural regeneration was due to the great difference in substrate elevation between the ponds and the bunds, therefore hindering the natural establishment of mangroves and propagation of their saplings.

As such, as per the recommendation by the research study by NUS, this Project shall employ the Ecological Mangrove Restoration (EMR) method which focuses on the restoration of the physical environment to favourable conditions for mangrove establishment. This will be further elaborated in Section 3.5 below. The feasibility study suggested that EMR can be done through local soil adjustments via filling works to match its surrounding natural mangrove environment in order to increase the likelihood of successful mangrove seedling establishment. In addition, since the original topography and natural drainage patterns were altered due to the construction of prawn farms, the drainage and hydrology of the surrounding areas should also be further studied to promote sedimentation and accretion in the Ponds. Therefore, the Project was proposed in consideration of the current conditions of the Project Site, and the Project's conceptual design was aligned with the abovementioned feasibility study.

Indirectly, mangroves also serve social ecosystem services. As the first application of the EMR method in Singapore, this Project provides an opportunity to educate the public on mangrove restoration, including the showcasing of the progress of an EMR approach. To enhance public engagement, educational signages and earth trails was proposed to be placed and constructed around the Sungei Durian Ponds area.

3.5 Principles of Ecological Mangrove Restoration Method

The Ecological Mangrove Restoration (EMR) method is a six-step process that includes the assessment of the physical environment of the Project Site and to conduct restoration works to improve the hydrological conditions and elevations within the Site. This EMR method was preferred over the less robust alternative mangrove restoration method – mangrove samplings plantation approach – which was prone to failure due to a lack of consideration towards the physiological tolerance of mangroves to tidal inundation [P-54]. While the EMR method may require a longer duration for the natural recruitment of mangroves, the long-term benefits from a higher species diversity and biomass eventually outweighs this [P-55].

Often practiced in the United States to create mangrove sites in a cost-effective and ecological manner, the EMR method has been introduced to Southeast Asia, with great success, and its effectiveness has been increasingly proven in scientific literature. EMR projects in both North and South Sulawesi, Indonesia, saw successful natural recruitment of mangroves after initial rehabilitation [P-56]. *Sonneratia alba* and *Rhizophora apiculata* were successfully recruited after 32 months of initial rehabilitation in South Sulawesi. Brown et al. (2014) found that there has been significant recruitment of mangroves into the rehabilitated ponds and had reached the target densities within 2 - 3 years of ecological and hydrological rehabilitation [P-56].

The six steps of the EMR method are as follows:

1. Understand mangrove species ecology, including reproduction and their establishment;
2. Understand the hydrology and elevation that controls mangrove establishment and distribution;
3. Assess the reasons that are currently preventing natural mangrove establishment;
4. Select the most appropriate restoration site, based on Step 1 to Step 3;
5. Design the restoration site to restore the appropriate hydrology and utilize natural seedling recruitment; and
6. Plant seedlings in the correct environmental location, if a greater seedling density is required.

In relation to the EMR process, the feasibility study conducted by NUS has completed the first three steps of the EMR process, as it identified the key reasons why the mangroves were unable to naturally re-establish at this Site. The study also proposed for the restored Site design to have three platforms with decreasing elevations, where each of these platforms can target the recruitment of mangrove species associated with each specified elevation [P-35]. As such, having adopted this idea, the Project's proposed filling works in this Project targets Step 4 and Step 5, which is to design and restore the Site to suitable hydrology and elevations for mangrove recruitment, which

is being carried out concurrently by AECOM's engineering design team. This EIA serves to assess the potential impacts arising from the construction and operation of this EMR mangrove restoration project.

3.6 Prospective Development Plans

The application of Ecological Mangrove Restoration (EMR) at the Project Site will be achieved through earth backfilling works to develop slopes in Pond 2 and Pond 3 which allows for a continuous gradient connecting the bunds to the base of the Pond. Additional construction works were also proposed to improve the hydrology and hydrodynamics within the Project Site, which serves to enhance the mangrove restoration process. As the mangrove restoration process will be showcased to the public, there will also be construction works for public access infrastructure and amenities within the vicinity of the Project Site. This section shall detail the conceptual design for the abovementioned works.

3.6.1 Overview of Development Plans

The overall site plan of the proposed developments within and in the vicinity of the Project Site is presented in Figure 3-4, which can be categorised into three main types:

1. Earth filling works in Pond 2 and Pond 3 to improve the site conditions to promote mangrove establishment (refer to Section 3.6.2).
2. Improvement works for site hydrology and hydrodynamics (refer to Section 3.6.3), which includes the following:
 - a. Two (2) drain inlets;
 - b. Gabion block walls and soil investigation works for detailed design; and
 - c. Channel between Pond 1 and Pond 2.
3. Improvement works for public access and amenities (refer to Section 3.6.4), which includes the following:
 - a. Van drop-off and parking area;
 - b. Bicycle parking area;
 - c. Reinstatement of earth trails;
 - d. One (1) single-storey shelter and soil investigation works for detailed design;
 - e. Two (2) lookout areas;
 - f. Information boards and regulatory signages;
 - g. Three (3) fences/gates; and
 - h. One (1) small mound along the bund between Pond 2 and Pond 3.



Legend

- Sungei Durian Ponds Project Site
- Gates
- Temporary Access Roads
- Lookout Decks
- Parking (Bicycles)
- Parking (Vans)
- Shelter
- Mound
- Earth Trails
- Gabion Blocks
- Drainage Inlet
- Channel

Procured Design Soil Mix

- +2.8mCD
- +2.6mCD
- +2.6mCD
- +2.4mCD
- +2.4mCD

Generated Fill Material

- +2.8mCD
- +2.6mCD
- +2.4mCD

Rev.	Date	By	Description	Chk'd	App'd
-	AUG 2022	CQA	EIA Report	NHT	JAG

Qualified Person Endorsement :
NA

NParks Endorsement : NA

Consultant : **AECOM**

Project Title :
**CONTRACT NPARKS/N/39/2017
CONSULTANCY SERVICES FOR SHORELINE
WORKS IN PULAU UBIN
(MANGROVE RESTORATION OF
SUNGEI DURIAN PONDS)**

Designed CQA	Checked NHT	Approved JAG
	Drawn CQA	Date AUG 2022

Client:

Figure Title :
**Overall layout plan of proposed
developments at Project Site**

Figure No. : 3-4	Rev. -	Sheet 1 of 1
CAD File Name : NA		A3

3.6.2 Earth Filling Works at Ponds

This section presents the conceptual design plan of the proposed earth filling works at the Project Site and the background on the source of the fill material used for the filling works.

3.6.2.1 Conceptual Design Plan

As described in Section 3.4, the main aim of this Project is the restoration of the Project Site to suitable elevations to enhance natural mangrove regeneration. To achieve this, earth filling works were proposed within Pond 2 and Pond 3 (refer to Figure 3-5). The conceptual design for the EMR works within the Sg. Durian Ponds was developed based on scientific evidence and technical consultations.

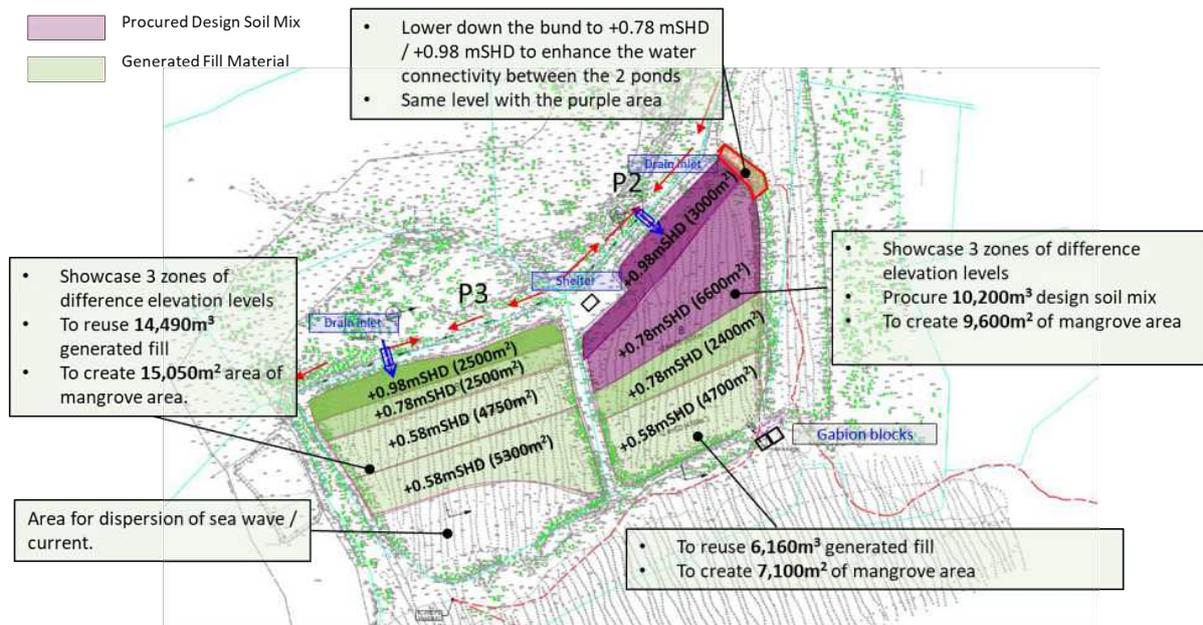

Note: Layout is based on Tender return outcome 2- Headland + Sg Besar toe protection + Noordin beach nourishment

Figure 3-5 Conceptual design of earth filling works

As shown in Figure 3-5, two slopes will be constructed along the edges of the existing bunds and slopes downwards to the base of the Pond, transitioning through three platforms with elevations of +0.98 mSHD, +0.78 mSHD and +0.58 mSHD, respectively, via gentle slopes with 1:10 gradient. The cross-section of the design is presented in Figure 3-6. The filling works at the ponds were designed and optimised based on the existing site conditions and hydrodynamic simulations which identified areas with low current velocity and therefore less likely to be eroded over time (i.e. shape of the slope in Pond 3).

Table 3-1 Volume of fill used and mangrove area generated in Pond 2 and Pond 3

	Created Mangrove Area (m ²)	Volume of Fill Used (m ³)	
		Generated Fill Material	Design Soil Mix
Pond 2	16,700	6,160	10,200
Pond 3	15,050	14,490	-
Total	31,750	20,650	10,200

The slopes will be constructed using both generated fill material from dredging works in the concurrent project in northern Pulau Ubin (in green, see Figure 3-5) and from procured design soil mix (in purple, see Figure 3-5). As

shown in Table 3-1, the earth filling works in Pond 2 and Pond 3 is estimated to require a total of 30,850 m³ fill material to create 31,750 m² of mangrove area.

This slope design provides platform levels for mangrove regeneration at three different elevations. The concept of the slope design was developed based on the recommendations from the feasibility study conducted by NUS [P-35] and design was further refined using findings from the recent bathymetric survey conducted within the Site and the detailed hydrological and hydrodynamic analyses. Due to the different elevations, each platform level will have a different inundation period, which results in the establishment of different mangrove species. The list of expected mangrove species recruited at each tier was extracted from the feasibility study report and presented in Table 3-2. As shown in the cross-sectional view of the proposed filling works (Figure 3-6), the water level is expected to rise above the highest tier of +0.98 mSHD during mean high tide level (i.e. +1.2 mSHD), while the lowest tier will be located above the mean low tide level (i.e. -1.0 mSHD) at +0.58 mSHD. Mud-filled biodegradable coir fibre bags will be placed at the foot of each slope to protect the slopes from erosion by wave action, as shown in Figure 3-6.

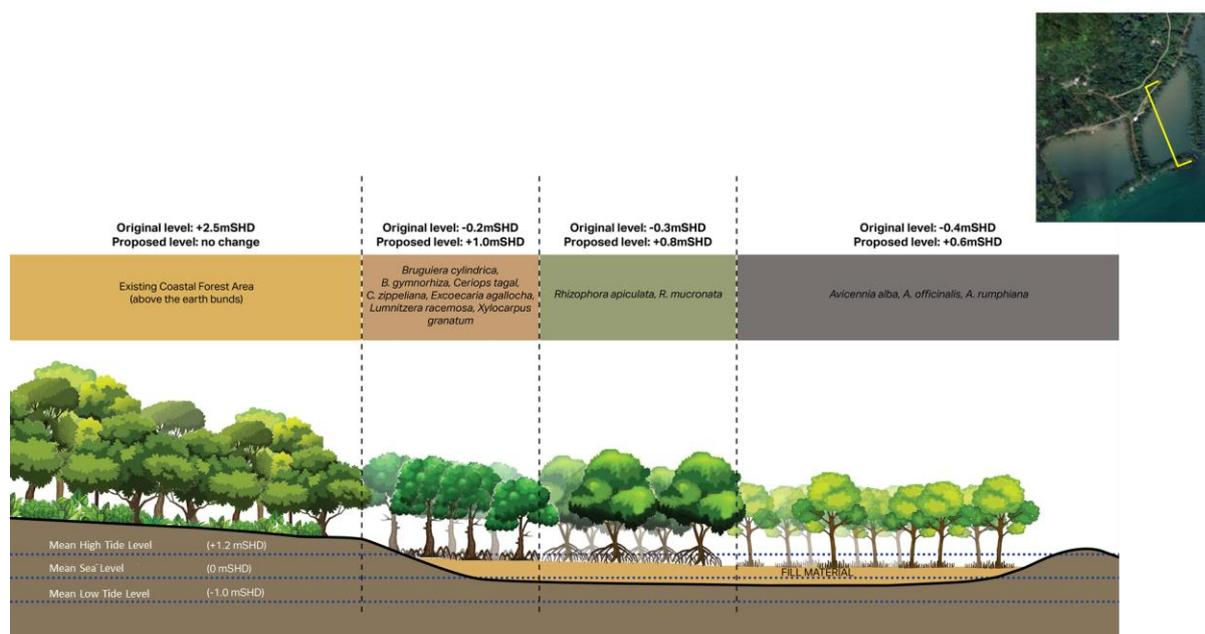

Figure 3-6 Cross-sectional area of mangrove islands

Table 3-2 Species of mangroves potentially recruited [P-35]

Potential Recruitment of Mangroves (Levels)				
Mangrove Species	Metres above MSL	Metres with respect to Chart Datum (mCD)	Metres with respect to Mean Reduced Level (mRL)	Metres with respect to Singapore Height Datum (mSHD)
<i>Avicennia alba</i> , <i>Avicennia officinalis</i> , <i>Avicennia rumphiana</i> , <i>Bruguiera cylindrica</i> , <i>Bruguiera gymnorrhiza</i> , <i>Ceriops tagal</i> , <i>Ceriops zippeliana</i> , <i>Excoecaria agallocha</i> , <i>Lumnitzera racemosa</i> , <i>Rhizophora apiculata</i> , <i>Rhizophora mucronata</i> , <i>Xylocarpus granatum</i>	1.0	+2.8	101.1	+0.98
<i>Avicennia alba</i> , <i>Bruguiera cylindrica</i> , <i>Rhizophora apiculata</i> , <i>Rhizophora mucronata</i>	0.8	+2.6	100.9	+0.78
<i>Sonneratia alba</i> , <i>Rhizophora apiculata</i>	0.6	+2.4	100.7	+0.58
Note: Mean sea level (MSL) is equivalent to -0.02 mSHD. The existing Pond bed elevation is approximately -0.52 mSHD.				

After completion of the filling works (Figure 3-7), the Site will be left to naturally recruit the mangroves, which will mainly take place through the dispersal of propagules from the existing mangroves in the vicinity. In the long-term, it is expected that the mangroves will regrow within the restored Ponds (refer to Figure 3-8).



Figure 3-7 3D rendering of Sg. Durian Ponds before and just after construction.



Figure 3-8 3D rendering of Sg. Durian Ponds after construction and after mangrove establishment.

3.6.2.2 Source of Fill Material

There are two sources of fill material used for the earth filling works in this Project, procured design soil mix and generated fill material.

The first type of fill material, design soil mix with desired composition, will be procured and deposited into the Ponds. The soil composition selected for this design soil mix is approximately 10% sand and 90% silt and clay, this was decided based on literature review. The literature review provided an overview of the soil compositions in tropical mangrove habitats in Southeast Asia (e.g. Malaysia, Thailand and Indonesia) to support the selection of soil composition. A study found that mangroves could thrive in habitats with high silt/ clay content (>70%) and low sand content (<30%) [P-73, P-74, P-75].

The second type of fill material, generated fill material, is obtained from the sandkey dredging works for shoreline restoration project at Noordin Beach and Mamam Beach located at the north of Pulau Ubin. The construction phase of this shoreline restoration project will be taking place concurrently with the construction phase of this Project. The dredged material will be repurposed as fill material for the proposed earth filling works at this Site. Three (3) headlands would be constructed at Noordin Beach and one (1) headland would be constructed at Mamam Beach.

3.6.3 Improvement Works for Site Hydrology and Hydrodynamics

To supplement the mangrove restoration efforts within the Project Site, additional works will be conducted to improve the local Site hydrology and hydrodynamics. These improvement works include the construction of drain inlets, gabion block walls and the creation of a channel between Pond 1 and Pond 2.

3.6.3.1 Drain Inlets

Two drain inlets (denoted as 'drain inlet 1' and 'drain inlet 2') were proposed to be constructed in the north of Pond 2 and Pond 3, respectively (Figure 3-5). These inlets will redirect the runoff from their respective catchments and into the Ponds, which will facilitate the natural deposition of sediments to ensure the sustainability of this mangrove restoration efforts in the long-term. Each proposed culvert drain will be 1 m width by 1 m depth, with a total drain length of approximately 10 m. Stones will be placed at the outlets to minimise local scouring which may occur during heavy storm events. The drain was sized to cater for maintenance and to avoid trapping fauna.

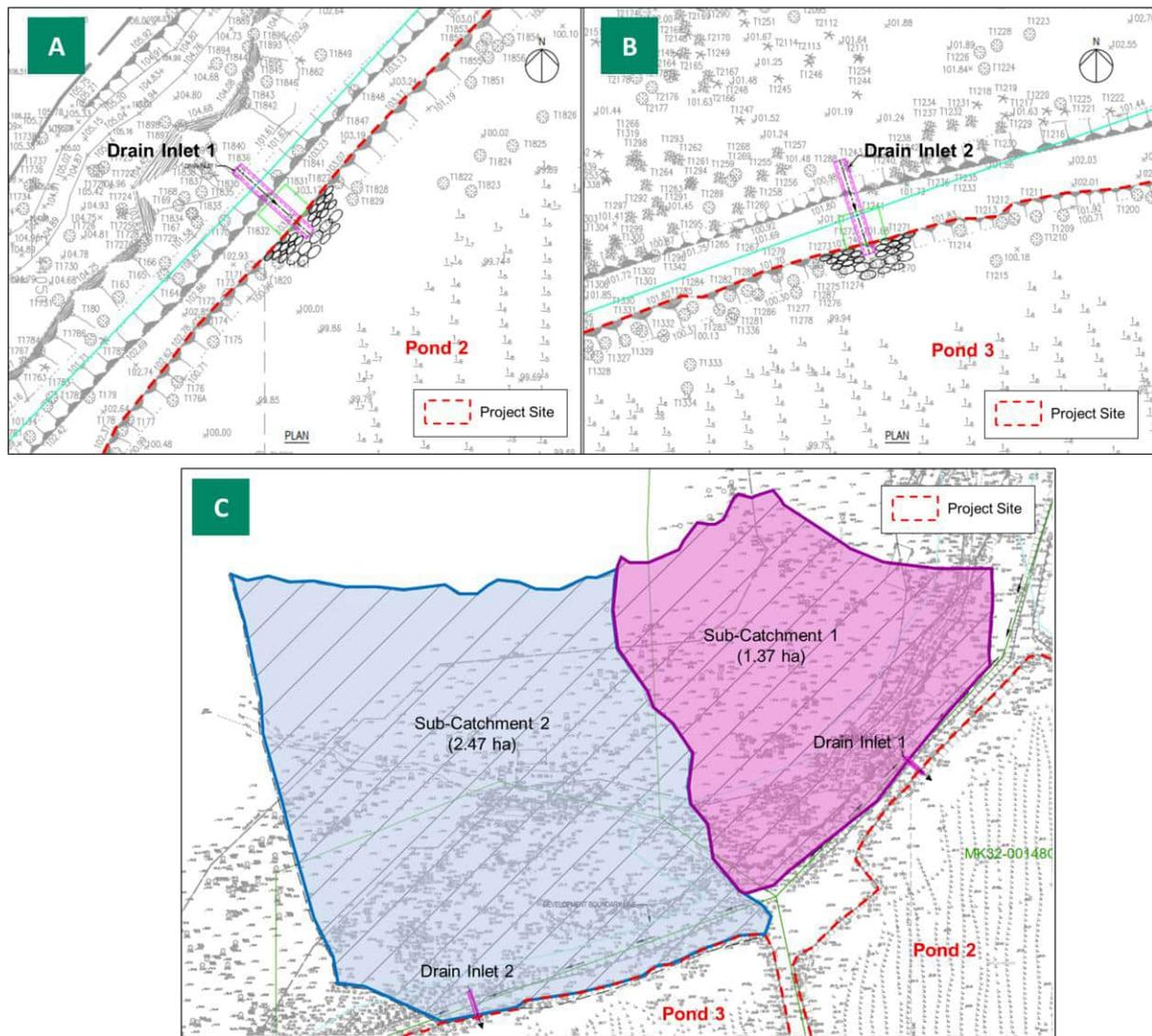

Figure 3-9 Layout plan of proposed drain inlets: (A) Drain inlet 1 at Pond 2, (B) Drain inlet 2 at Pond 3, (C) Sub-catchment areas of drain inlet 1 and drain inlet 2.

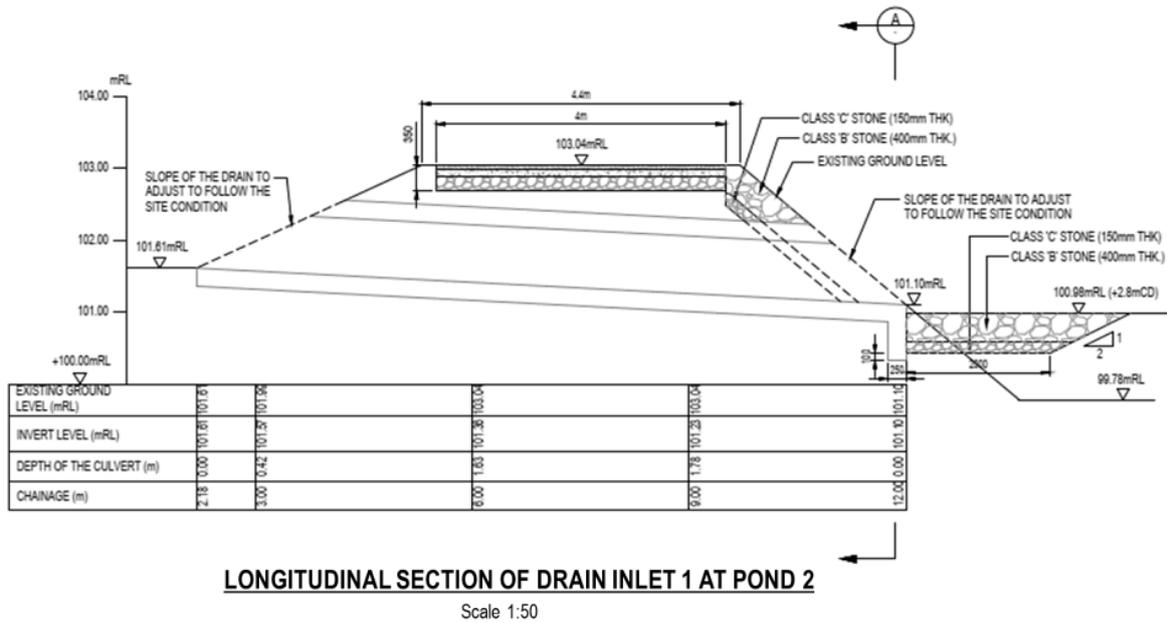

Figure 3-10 Cross-sectional view of proposed drain inlet 1 at Pond 2.

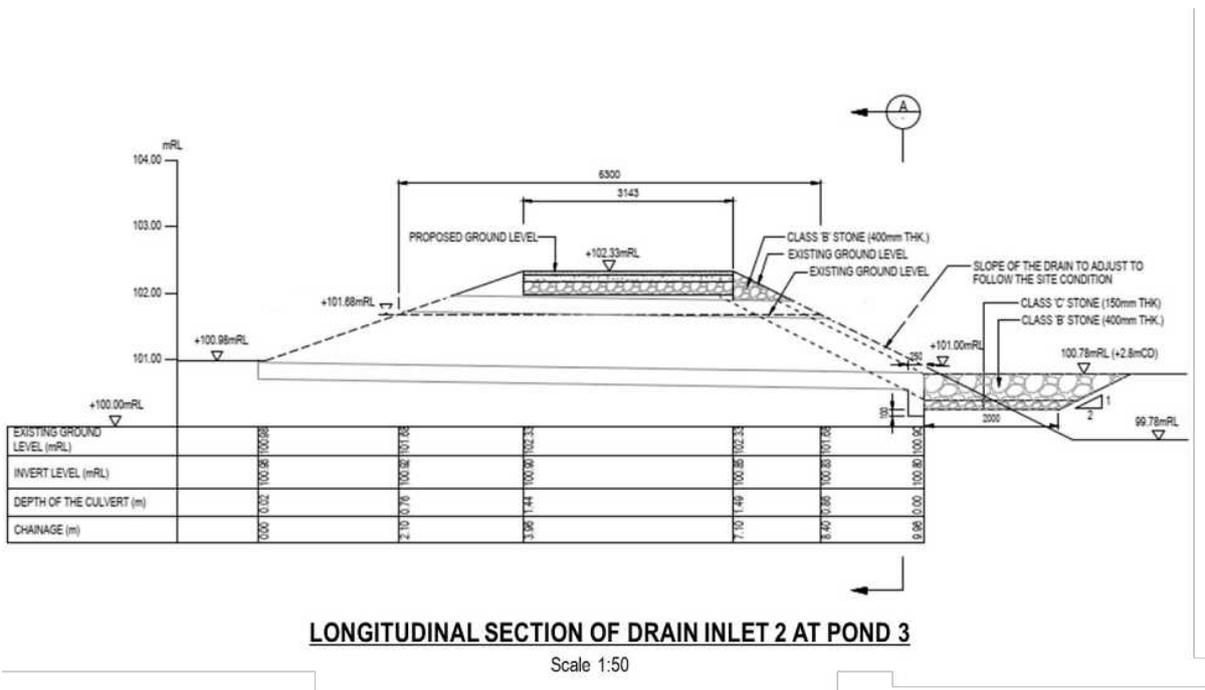

Figure 3-11 Cross-sectional view of proposed drain inlet 2 at Pond 3.

3.6.3.2 Gabion Blocks

Gabion block walls were proposed to be constructed at openings at the southwest of Pond 2 and south of Pond 1. These gabion blocks will be placed at the gaps between the two existing sluice gates and next to the existing bund walls (refer to Figure 3-12) to reduce current velocity at the openings, which therefore minimises the soil erosion after completion of the earth filling works in Pond 2. The maximum height of the proposed gabion blocks is +0.58 mSHD, which is aligned with the lowest level of the Pond 2 after filling works (Figure 3-13). During low tide, the seawater can flow through the gabion blocks slowly, while during high tide, the seawater can flow in and out of the Ponds freely.

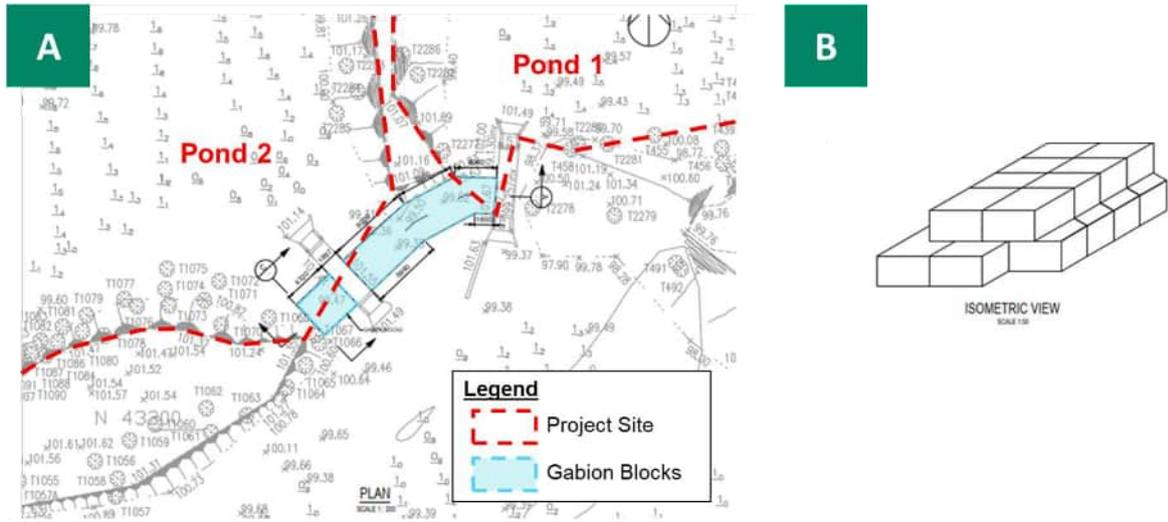

Figure 3-12 (A) Plan view of gabion block walls at Pond 1 and Pond 2 openings, (B) Isometric view of gabion block walls.

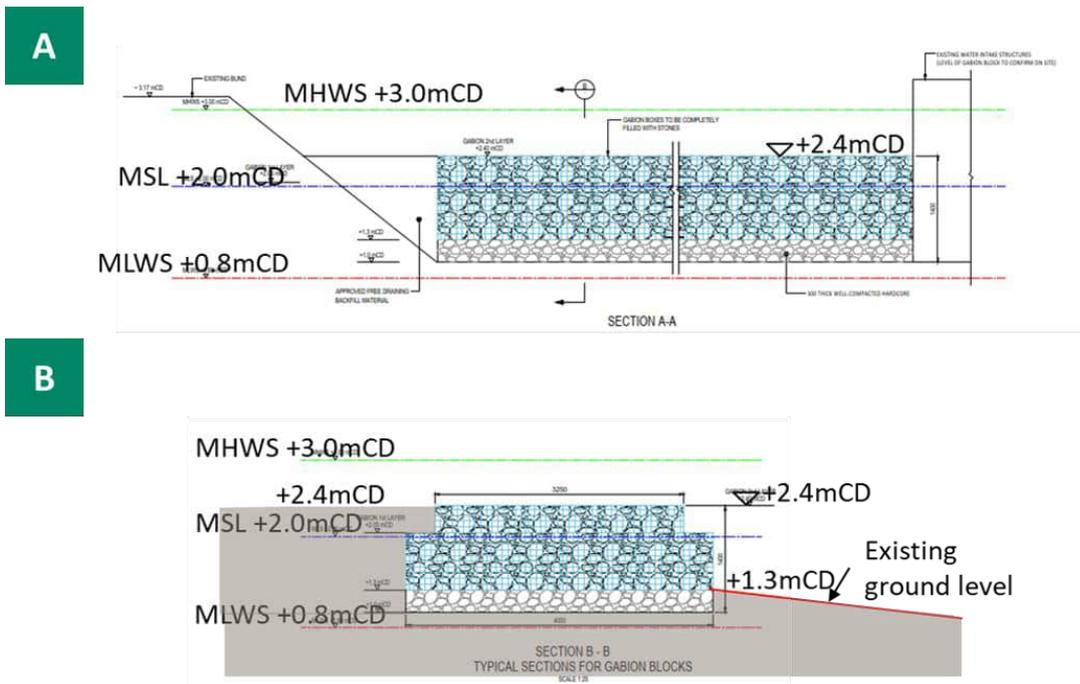

Figure 3-13 Section view of gabion block walls.

3.6.3.3 Channel between Pond 1 and Pond 2

A section of the bund wall will be lowered to enhance the water connectivity between Pond 1 and Pond 2. While this already occurs between Pond 1 to Pond 2 during high tide, the lowering of the bund wall will enhance the sediment transport from Pond 2 into Pond 1 to promote mangrove recruitment.

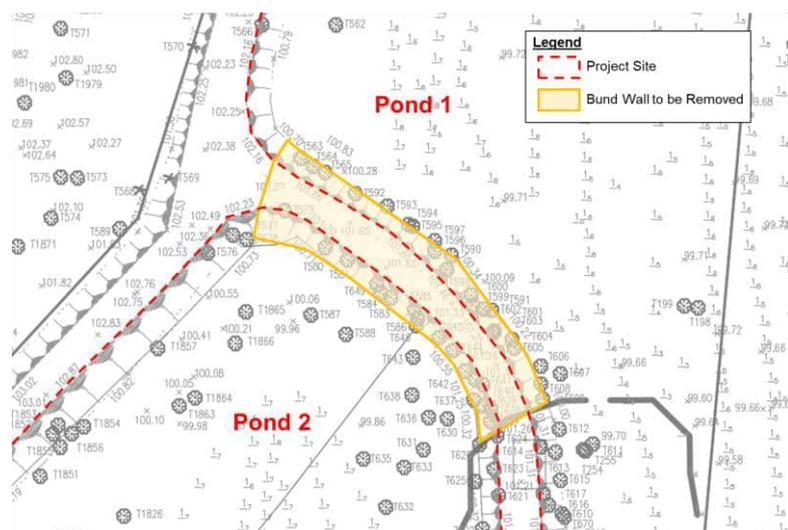

Figure 3-14 Plan view of the section of the bund wall that will be removed.

3.6.4 Improvement Works for Public Access and Amenities

During the operational phase, the Project Site is expected to be opened to the public to showcase the mangrove restoration progress. Improvement works were proposed to improve the overall public accessibility to the Site and to enhance the provision of public amenities within the Site (refer to Figure 3-15).

Firstly, transport infrastructure such as a van drop-off and parking area, bicycle parking area and repaired rustic trails were proposed to improve public accessibility to the Project Site. The proposed van drop-off and parking area will not be paved and will be kept as earth trails. The bicycle parking area will be constructed with metal grating to ensure that it is wild boar-proof. The existing trails will be graded (i.e. especially the existing slop near the entrance to the site) and laid with coarse granite aggregates to improve the paths along the bunds. Secondly, a single-storey shelter and two (2) lookout areas were also proposed to enhance the public's viewing experience of the mangrove restoration site. The proposed shelter will be constructed at the northwest of Pond 2, while the two lookout areas are located north of both Pond 2 and Pond 3 (Figure 3-16A). The shelter elevation is at approximately 104.5 mRL and will not be inundated during high tide (Figure 3-16B). Thirdly, other Site furnishes to be installed onsite include one (1) tidal marker in the northeast of Pond 2 and information boards and regulatory signages placed around the Site. To restrict access and ensure public safety, three (3) fences/gates will be constructed at the end of the earth trail. Lastly, one (1) small earth mound (0.8 m in height) will be constructed along the bund between Pond 2 and Pond 3 to block the view of the fencing/ gate located at the end of this same trail to further restrict access and avoid attracting the public's attention for safety purposes.



Figure 3-15 Location of site infrastructure and amenities.

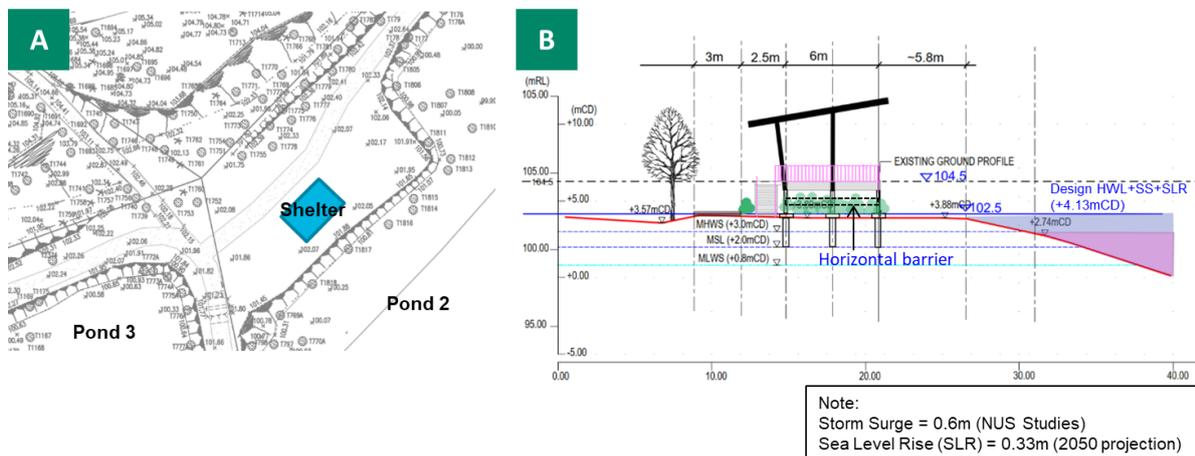

Figure 3-16 (A) Location of proposed shelter, (b) Section view of shelter.

3.7 Proposed Activities During Construction Phase

This section provides details on the methods of construction for the earth filling works, improvement works on site hydrology and hydrodynamics and provision of infrastructure for public access and amenities. Subsequently, the method statements from this section were assessed for potential environmental impacts and mitigation solutions were provided to ensure that identified impacts were minimised.

3.7.1 Channel between Pond 1 and Pond 2

The earthworks to create a channel between Pond 1 and Pond 2 will first be conducted, prior to the main earth filling works in the Project Site. Minor site clearance may be required to remove the trees along the identified section of the bund wall. A section of the bund wall will be excavated by an amphibious excavator. The excavated soil will be temporarily stored onsite and later reused for the filling works in the Ponds.

3.7.2 Earth Filling Works at Ponds

The overall construction methodology for the earth filling works at Pond 2 and Pond 3 consists of three (3) main activities: transportation of fill material, storage of excess fill material at temporary staging area and backfilling works at the Ponds.

3.7.2.1 Transportation of Fill Material

As presented in the conceptual design in Figure 3-5 and explained in Section 3.6.2.2, procured design soil mix will be utilised for filling works in Pond 2 and Pond 3, while dredged material will be filled in Pond 3. This section describes the transportation process of the different fill material to the site, and subsequently into the Ponds.

The procured design soil mix will be transported by flattop barge to the Project Site via an offsite staging area to the Project Site. On the other hand, the sandkey dredged material produced from the concurrent project at Noordin Beach in the north of Pulau Ubin will be loaded onto a flattop barge (Figure 3-19) and transported to the Project Site with tugboat assisted. The tugboat proposed for this Project has a length of 8.5 m, beam of 3.78 m, depth of 1.38 m and tonnage of 12.7 tonnes. The proposed route for the transportation of the material is approximately 6.5 km and will pass by the ecologically sensitive site Chek Jawa Wetlands and the cluster of aquaculture farms located at the south of the Project Site. It should be highlighted that the flattop barge will skirt around the restriction zone of Chek Jawa Wetlands (Figure 3-18). The transportation of dredged material to the Project Site will require approximately 28 to 60 trips, spread over a period of 12 months. The trip frequency per day is dependent on the progress of dredging works at Noordin Beach.



Figure 3-17 Overview of transportation process of the dredged material to the Project Site

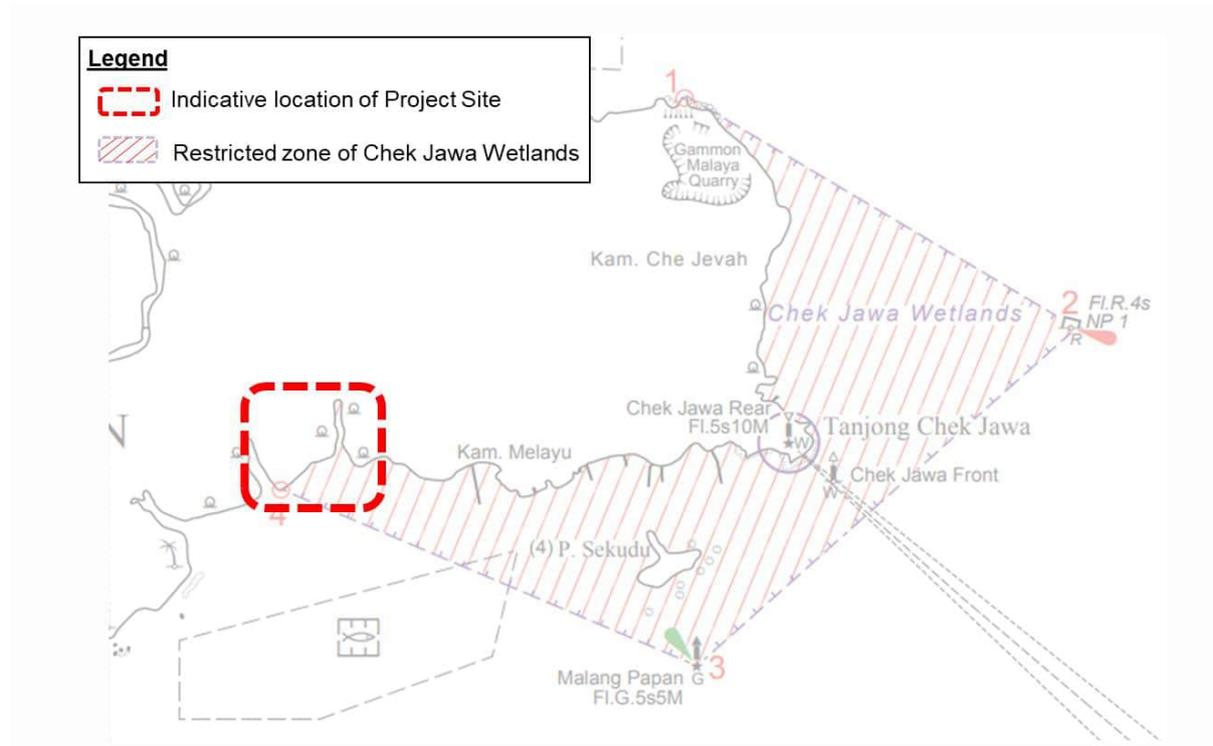

Figure 3-18 Map of the restriction zone of Chek Jawa Wetlands (source: MPA)



Figure 3-19 An example of a flattop barge.

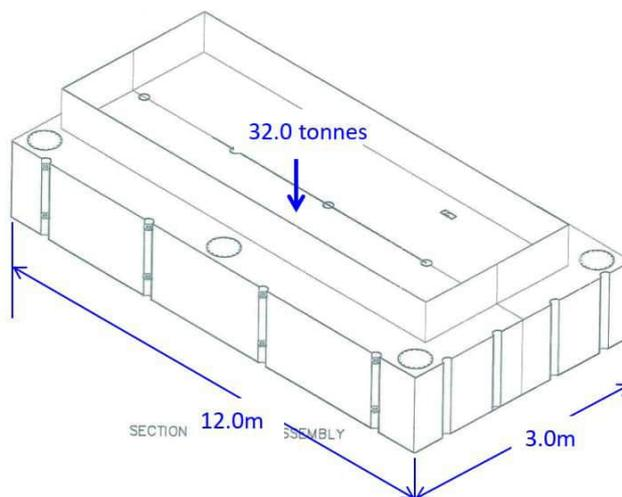

Figure 3-20 An example of a modular barge.

Currently, the access to the Project Site is restricted by sluice gates, and the seabed depth near the Project Site is too shallow to accommodate the flattop barge even during high tide condition. Hence, upon arriving near the Project Site, the design soil mix/ dredged material will be manually transferred from the flattop barge to a modular barge (Figure 3-20), which will then be manually towed into Pond 2 and Pond 3. The modular barge has a floating capacity of 32.5 tonnes and is 12 m in length, 3.0 m in width and height of 1.5 m.

3.7.2.2 Storage of Fill Material at Temporary Staging Area

Upon being transported into the Ponds, the fill material will either be dumped directly into the filling site or stored at the temporary staging area which is located at the northwest of Pond 2 (Figure 3-21). This temporary staging area is 40 m by 20 m and is designated to store the excess fill material while waiting to be utilised for pond filling.

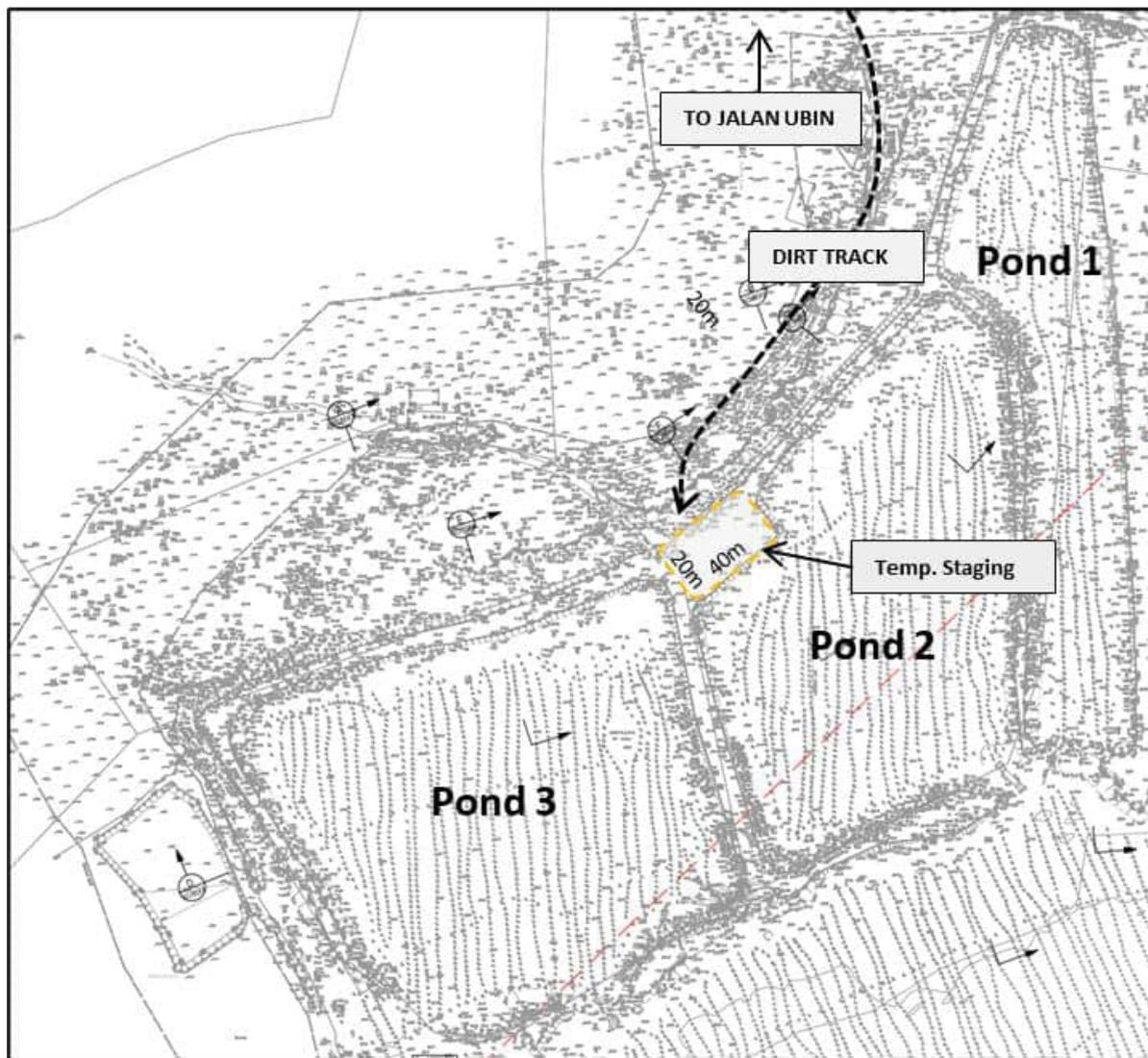

Figure 3-21 Temporary staging area of fill material.

3.7.2.3 Earth Filling Works

Earth filling works will be carried out in Pond 2 and Pond 3 via manual filling or using an amphibious excavator Figure 3-22. Subsequently, the excavator will be used to compact and level to the desired platform levels of +0.98 mSHD, +0.78 mSHD and +0.58 mSHD. The mud-filled biodegradable coir fibre bags will be placed at the toe of the slope before earth filling to avoid the soil to be wash out during the filling process.

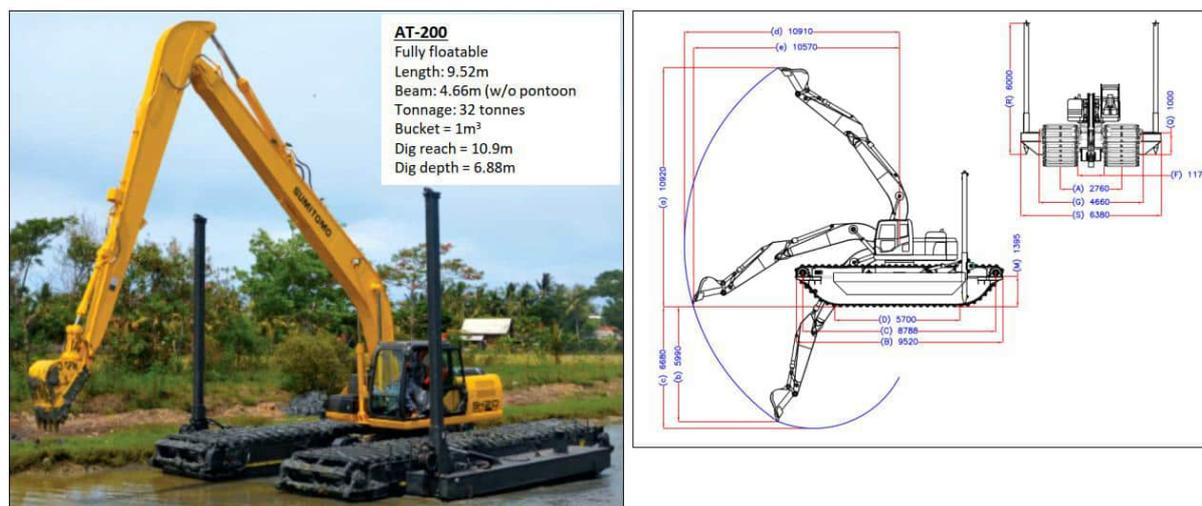

Figure 3-22 An example of an amphibious excavator.

3.7.3 Construction of Drain Inlets

The construction works for the drain inlets will be carried out concurrently with the earth filling works in the Ponds. Minor site clearance will first be required to clear existing vegetation at the proposed drain's location. Next, excavation to the drain's base level will be carried out according to approved drawings. Once the excavation works are completed, construction of the foundation which consists of a 300mm thick well-compacted base will be carried out subsequently. Installation of formwork is required to be done before reinforcement and concreting work are carried out. The proposed drain culvert can also be prefabricated off-site and transported and installed on site. After the culvert is constructed, soil filling and regrading works will be carried out. The prefabricated culvert, stones, and other construction materials were transported to the site by lorry through Jalan Durian. At the drainage outlet, Class C stones will first be laid, followed by another layer of Class B stones using an amphibious excavator.

3.7.4 Construction of Gabion Blocks

Before the construction of the gabion blocks begins, a soil investigation is expected to carry out to verify the actual soil condition on site. The soil investigation is likely to adopt the rotary drilling method and the equipment used is Rotary Drilling Machine.

The gabion blocks will be constructed once the earth filling works is completed. The construction of gabion blocks will first require foundation works, during which the soil will be compacted using an excavator on the flattop barge or amphibious excavator. Next, the gabion block cage will be lowered onto the well-compacted base. The cage will be filled with stone using the excavator and this will make up the first layer of the gabion block wall. The next layer of gabion block cages will be lowered, and the process will repeat till the desired elevation levels of +0.98 mSHD.

3.7.5 Construction of Public Access Infrastructure and Amenities

The construction of the van drop-off and parking area, bicycle parking area, repairing of rustic earth trails, shelter, lookout areas, fences/gates and small earth mound will be constructed in the terrestrial environment. Minor site clearance and grading works will be required to create access roads from the main road of Jalan Durian to the Project Site.

- Van drop-off and parking area

Minor site clearance and grading will need to be carried out to create an open area for Van drop-off and parking areas. Vegetation clearance is expected to be very minimal as the construction areas are already on existing paths and clearings.

- Bicycle parking area

Minor site clearance and grading works will need to be carried out to level the ground. The entrance of the bicycle parking area will be excavated to create a trench, where a metal grating cover will be used. The use of the metal grating would ensure that the bicycle parking area is wild boar-proof.

- Shelter and Site investigation works

Before the construction of the shelter begin, a soil investigation is expected to carry out to verify the actual soil condition on site. The soil investigation is likely to adopt the rotary drilling method and the equipment used is Rotary Drilling Machine.

Minor site clearance will first be required to clear existing vegetation at the proposed shelter's location. Next, Piles installation work will be carried out. Once the pile installation is completed, pile cap concreting works will be carried out. Installation of formwork is required to be done before reinforcement and concreting work are carried out. After the foundation works are completed, the supporting structures of the shelter which consists of the steel column, beam, and roof frame will be erected. Roof metal sheet will then be installed on the roof frame.

- Lookout Areas

As the lookout areas are constructed above the drainage inlets. The lookout area is an open area with engineered timber / composite timber finishing. Before laying the engineered timber / composite timber, a proper well-compacted base, and concrete base are required to be casted. The engineered timber / composite timber will be mounted on Aluminium framed with adequate spacing.

- Small earth mound

The 0.8-m high earth mound will be constructed by soil filling, compaction and grading using an excavator.

- Fence/ gates, Information boards, Regulatory signages

These site furnishing will be transported to the Site and installed once the above activities are near completion.

- Reinstatement of earth trails

During reinstatement of the Site, the earth trails will be elevated and/or graded. Thereafter, gravel base aggregates will be placed above the trails.

3.8 Proposed Activities During Operational Phase

Following the completion of construction works, there will likely be an increase in human activity within the Project Site. As the Project Site will be opened to the public as an educational site to showcase the progress of mangrove restoration, an increase in human activities such as trekking and educational tours, would be expected within the Project Site. These activities may result in potential water pollution and biodiversity impacts to the Project Site and its vicinity.

3.9 Project Schedule

The construction works for Project Site will commence from mid-2023 to 2025, which will last for about twenty-four (24) months. The exact construction timeline is still not confirmed at the time of report writing.

3.10 Other Major Concurrent Developments

A few upcoming developments were identified within the vicinity of the Project Site. As this Project does not involve any major construction activities in water (i.e. the Project's main construction activity involves the filling the Ponds either manually or mechanically using an amphibious excavator), the associated environmental impacts are mainly localised, which was determined through modelling and will be illustrated in detail later in Section 7.7. As such, only concurrent construction projects within 2-km distance, such as shoreline restoration at Noordin Beach and Mamam Beach, enhancement of fire safety infrastructure at Main Village and Malay Kampung, will be considered during the assessment of cumulative impacts from nearby concurrent projects.

Other projects that are located more than 2-km away, such as enhancement of fire safety infrastructure at Ubin Living Lab (ULL), the construction of jetty at ULL and land reclamation works at Pulau Tekong, were not considered for cumulative impact assessment. This is in consideration that these projects are located at a substantial distance

away from the Project Site and that the impact from this Project is expected to be localised (refer to Section 7.7), and thus these projects are unlikely to contribute cumulative environmental impacts associated with this Project.

Other notable development in the vicinity of the Project Site whose construction phase does not overlap with this Project's timeline include the Shoreline restoration at Sungei Jelutong (i.e. beyond 2030). The proposed works will not contribute to the cumulative impacts of this Project.

The timelines of the concurrent developments are presented in Table 3-3, while the locations of these abovementioned developments are presented in Figure 3-23.

Table 3-3 Construction timeline of major developments in the vicinity of Project Site

Development	Description	Construction Timeline
Located within 2-km radius of Project Site (i.e. concurrent projects)		
Shoreline restoration at Pulau Ubin (includes Noordin Beach, Mamam Beach)¹ (Figure 3-23)	Includes the construction of headlands at Noordin Beach. Most of its construction period will overlap with this Project's construction phase during the first 12 months.	Nov 2022 to Apr 2024
	Cliff stabilisation works at Noordin Beach. Its construction period overlaps with this Project's construction phase during its last 5 months and its subsequent operational phase.	Jun 2024 to Jun 2026
	Headland and toe protection works at Mamam Beach. Most of its construction period will overlap with this Project's construction phase during the first 12 months.	Nov 2022 to Apr 2024
	Toe protection works at Sg. Besar. Most of its construction period will overlap with this Project's construction phase during the first 12 months.	Nov 2022 to Apr 2024
	Includes construction of water tank on grade and hose reel network at Malay Kampung, and the construction of pumphouse, hydrant network and hose reel network at the Main Village. Its construction period will overlap with this Project's construction phase for the first 5 months.	Jan 2022 to Sept 2023
Located beyond 2-km radius of Project Site		
Enhancement of Fire Safety Infrastructure for Pulau Ubin (includes Ubin Living Lab) (Figure 3-23)	Includes the construction of pumphouse, hydrant network and hose reel network at Ubin Living Lab. Its construction period will overlap with this Project's construction phase for the first 5 months.	Jan 2022 to Sept 2023
Construction of Jetty at Ubin Living Lab, Pulau Ubin (Figure 3-23)	Includes marine piling works, construction of gangway, pontoons and rock revetments. Its construction period will overlap with this Project's construction phase for the last 5 months.	Mid 2024 to End 2026

Development	Description	Construction Timeline
Reclamation works at Pulau Tekong (Figure 3-23)	Includes land reclamation works. There is a lack of information available on the construction works, but due to its significant distance from this Project Site, it is unlikely to contribute to cumulative impacts.	Ongoing



Legend

- Reclamation Works
- Shoreline Protection
- Fire Safety Infrastructure
- Jetty Works
- Sungei Durian Ponds Project Site
- Marine Waters

Rev.	Date	By	Description	Chk'd	App'd
-	AUG 2023	CQA	EIA Report	NHT	JAG

Qualified Person Endorsement :
NA

NParks Endorsement : NA

Consultant : **AECOM**

Project Title :
**CONTRACT NPARKS/N/39/2017
CONSULTANCY SERVICES FOR SHORELINE
WORKS IN PULAU UBIN
(MANGROVE RESTORATION OF
SUNGEI DURIAN PONDS)**

Designed CQA	Checked NHT	Approved JAG
	Drawn CQA	Date AUG 2023

Client:

Figure Title :
**Locations of construction projects
in the vicinity of Project Site**

Figure No. : 3-23	Rev. -	Sheet 1 of 1
CAD File Name : NA		A3

4 Relevant Regulatory Framework, International Standards and Guidelines

An indicative list of relevant legislative requirements applicable to the Project is provided in Table 4-1.

Table 4-1 Relevant regulatory framework, international standards and guidelines

Environmental Parameter	Applicable Legislation	Key Points
General	Singapore Biodiversity Impact Assessment (BIA) Guidelines, 2020 [R-9]	<p>This document is published by NParks to provide a framework guiding biodiversity impact assessments in Singapore. It recommends methods for conducting baseline survey and impact assessment, and subsequently provide information on developing the biodiversity component of an environmental. Management and monitoring plan (EMMP).</p> <p>Section 2 of this BIA Guidelines details the baseline study methods recommended for vegetation mapping, habitat mapping, hydrology (including waterbody mapping, water conditions, water quantity and water quality)</p> <p>Section 4 of the BIA Guidelines details the impact study methods recommended for water related biodiversity impacts.</p> <p>Section 5 of the BIA Guidelines details the mitigation measures developing protocols, i.e. avoid, minimise, remedy/repair/restore, and compensate/offset.</p> <p>Section 6 of the BIA Guidelines outlines the requirements for developing an EMMP.</p>
	Singapore Environmental Protection and Management Act, 2020 [R-10]	<p>An Act to consolidate the laws relating to environmental pollution control, to provide for the protection and management of the environment and resource conservation, and for purposes connected therewith.</p> <p>This Act regulates the discharge of trade effluent, oil chemical, sewage or other pollution into land and drains.</p>
Biodiversity	Singapore National Biodiversity Strategy and Action Plan (NBSAP), 2019 [R-1]	<p>This document provides a framework to guide biodiversity conservation efforts in Singapore. It intends to establish both policy frameworks and specific measures to ensure better planning and co-ordination in the sustainable use, management, and conservation of biodiversity.</p> <p>A holistic approach has been adopted where the input of various public sector agencies and nature groups have been taken into consideration in the preparation of the document.</p>
	Singapore Wildlife Act, Chapter 351, 2000 [R-2]	<ul style="list-style-type: none"> Any person who kills, takes or keeps any wild animal or bird, other than those specified in the Act, without a licence shall be guilty of an offence and shall be liable on conviction to a fine not exceeding \$1,000 and to the forfeiture of the wild animal or bird.

Environmental Parameter	Applicable Legislation	Key Points
		<ul style="list-style-type: none"> No person should take, destroy or has in possession the eggs if any wild bird during the specified time of the year or during the breeding season of the bird. As part of development works, the Developer shall be required to carry out any wildlife-related measure that the Director-General considers necessary to safeguard the health, welfare, safety of any wildlife or class of wildlife; public health or safety in relation to wildlife; or health of ecosystem.
	Singapore Parks and Trees Act, 2006 [R-3]	<ul style="list-style-type: none"> An Act to provide for the planting, maintenance and conservation of trees and plants within national parks, nature reserves, tree conservation areas, heritage road green buffers and other specified areas, and for matters connected therewith. No tree with a girth exceeding one meter (when measured 1-m from the ground) located within tree conservation areas and vacant lands should be cut or damaged without the prior approval of the relevant authorities; and No tree or plant will be cut or damaged if located within the heritage road green buffer. No person, vessel or craft shall enter or remain within the [Chek Jawa] Wetlands, unless a written permit has been obtained from NParks.
	Singapore Parks and Trees Act (Parks and Trees Regulations), 2006 [R-4]	Prohibitions and regulations on trees and animals within national park, nature reserve or public park.
	Singapore – Parks and Trees (Heritage Road Green Buffers) Order, 2006 [R-5]	Lists the areas designated as heritage road green buffers.
	Singapore Parks and Trees (Preservation of Trees) Order, 1998 [R-6]	Lists the designated tree conservation areas No cutting or damaging of tree having girth of more than one metre.
	The Singapore Red Data Book (SRDB) [P-8]	Lists the endangered plants and animals in Singapore Published by Singapore's Nature Society Provides the scientific name, common name, status, description, habitat, distribution, threats, scientific interest, and potential value, as well as conservation measures for each plant and animal listed.
	The International Union for Conservation of Nature and Natural Resources (IUCN) Red List of Threatened Species [R-7]	Provides taxonomic, conservation status and distribution information on plants, fungi and animals that have been globally evaluated.
	The Hong Kong Environmental Impact Assessment Ordinance - Technical Memorandum (HK EIAO TM) ¹ [R-8]	Sets out the principles, procedures, guidelines, requirements, and criteria for deciding whether the Project is environmentally acceptable.

¹ The HK EIAO TM was added as an applicable legislation for biodiversity because: (1) Singapore does not have an established standard for biodiversity assessment yet; (2) Singapore and Hong Kong share similar urban development setting; and (3) HK EIAO TM has previously been used for other environmental impact assessments in Singapore.

Environmental Parameter	Applicable Legislation	Key Points
Marine Water	Singapore National Environmental Agency (NEA) Water Quality Guidelines for Recreational Beaches and Fresh Water Bodies	Regulates the water quality parameter of <i>Enterococcus</i> count for recreational beaches
	Singapore Prevention of Pollution of the Sea Act, 1990 (revised 2008) [R-24]	An act to put into effect the International Convention for the Prevention of Pollution from Ships 1973, as modified by the Protocol of 1978, and to other international agreements in relation to the prevention, reduction and control of pollution of the sea and pollution from ships, and generally for the prevention reduction and control of pollution to the sea (MARPOL).
	Singapore Fisheries Act 1966 (revised 2002) [R-25]	Covers conservation and protection of fisheries resources.
	Singapore Sewerage and Drainage Act, 2001 [R-13]	An Act to provide for and regulate the construction, maintenance, improvement, operation and use of sewerage and land drainage systems, and to regulate the discharge of sewage and trade effluent. Regulates the protection, maintenance, and provision of stormwater drainage system.
	Singapore Sewerage and Drainage (Surface Water Drainage) Regulations, 2007 [R-15]	Regulates measures to be implemented to protect the stormwater drainage system.
	Singapore Sewerage and Drainage (Trade Effluent) Regulations, 2007 [R-14]	Regulates trade effluent discharge into public sewerage system.
	Singapore Environmental Protection and Management (Trade Effluent) Regulations, 2008 [R-11]	<ul style="list-style-type: none"> Regulates the discharge of trade effluent to public watercourse. Any discharge into a watercourse has to comply with the regulatory standards established in these regulations.
	Singapore PUB Code of Practice on Surface Water Drainage, 2013 (revised 2018) [R-16]	Provides guidelines for measures to be implemented to protect the stormwater drainage system and manage surface water drainage (e.g. development and implementation of an Earth Control Measures [ECM] plan).
	Singapore SS 593: 2013 – Code of Practice for Pollution Control (COPPC) [R-12]	<ul style="list-style-type: none"> Provides guidelines for the appropriate discharge of any effluent into public sewer or watercourse. Provides guidelines for the appropriate storage and accidental release of oils & chemicals.
	Singapore Allowable Limits for Trade Effluent Discharge to Watercourse or Controlled Watercourse (NEA) [R-20]	Provides allowable limits for trade effluent discharge to watercourse or controlled watercourse in Singapore.
Singapore PUB Circular on Preventing Muddy Water from the Construction Site, October 2015 [R-17]	All new construction sites with site area of 0.2ha and above, sites with problematic Earth Control Measures (ECM), and sites within sensitive areas are required to implement closed-circuit television (CCTV) including a Silty Imagery Detection System (SIDS) at the public drain to monitor the surface run-off discharges from the sites.	

Environmental Parameter	Applicable Legislation	Key Points
	ASEAN Marine Water Quality Management Guidelines and Monitoring Manual, 2008 [R-22]	Provides marine water quality criteria for the protection of the aquatic life in the coastal and marine environment and human health within ASEAN.
	United States Environmental Protection Agency (USEPA) Water Quality Standards Handbook, 2017 [R-18]	Provides standards for water quality assessment relating to aquatic life for marine waters.
Underwater Noise	American National Standards Institute (ANSI) Accredited Standards Committee S3/SC 1 Sound Exposure Guidelines for Fishes and Sea Turtles: A Technical Report, 2014 [R-31]	Provides current threshold levels for injury and behavioural changes, as well as sound exposure guidelines for fishes, sea turtles, fish eggs and larvae with regards to various sources of underwater noise (e.g. shipping and continuous sounds)
	United Nations Conservation of Migratory Species (CMS) Technical Support Information to the CMS Family Guidelines on Environmental Impact Assessment for Marine Noise-generating Activities, 2017 [R-26]	Provides standards for underwater noise levels for specific marine species groups, including marine mammals, fin fish and marine invertebrate.
	United States Technical Guidance for Assessing the Effects of Anthropogenic Sound on Marine Mammal Hearing: Underwater Thresholds for Onset of Permanent and Temporary Threshold Shifts, 2018 [R-27]	Provides threshold levels for underwater noise for various marine mammal species.
	European Commission Marine Strategy Framework Directive, Decision, 2010 (revised 2017) [R-28]	Provides criteria of underwater noise (low, mid, and high frequency impulsive sounds and low frequency continuous sounds) in marine environments and indicators to be measured.

5 EIA Approach and Methodology

This section outlines the approach and methodology followed for this EIA.

5.1 Approach

The overall EIA workflow is shown in Figure 5-1, and the general approach to the EIA is listed as follows:

- Scoping of EIA (Section 5.2);
- Data Collection and Analysis (Section 5.3);
- Prediction of Impacts (Section 5.4.1);
- Evaluation of Impacts (Section 5.4.2);
- Recommendations of Mitigation Measures (Section 5.5);
- Cumulative Impact Assessment (Section 5.6) and
- Environmental Monitoring and Management Plan (Section 8).

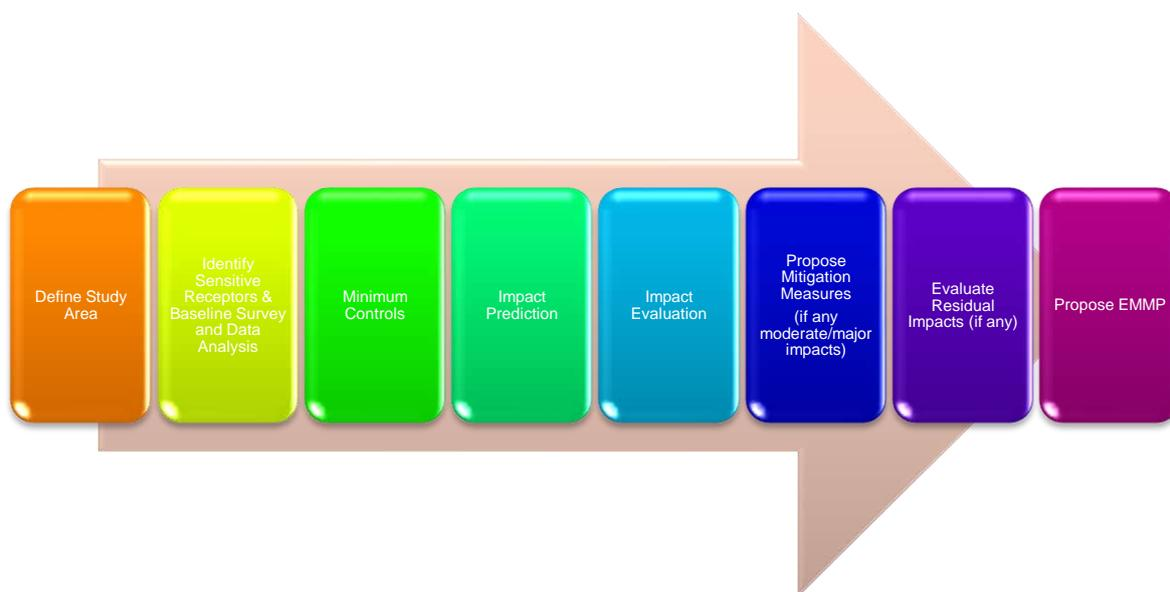

Figure 5-1 Overall EIA workflow.

5.2 Scoping of EIA

Referring to the Inception Report Rev 03 [O-2], the environmental impacts resulting from the construction and operational activities of this Project are assessed in this EIA report as follows:

- Biodiversity,
- Hydrodynamics,
- Water Quality (including sediment plume),
- Morphology, and
- Underwater Noise.

5.2.1 Identification of EIA Study Area

The Study Area defined for this EIA is presented in Table 5-1. The Study Area was used to determine any potential environmental impacts to the nearby sensitive receptors due to construction and operational activities from the Project Site. Study Area varied depending on the technical discipline and will be described respectively for each impact in the following chapters.

Table 5-1 Study Area for different environmental parameters

Environmental Impacts	Assessment Area (Construction and Operational Phases)	Justifications
Biodiversity	The Study Area for biodiversity impacts is defined as the habitats, flora and fauna within the Project Site and an additional 100 m buffer around the entire site. This area is about 16 ha in size, including the Project Site (i.e. the three ponds). The Ponds consists of approximately 4 ha of soft-sediment seabed, with 3 ha of marine intertidal areas outside of the Project Site. While the remaining 12 ha is largely terrestrial and mangrove vegetation.	When assessing impacts, impact zones for habitat and plant species receptors are defined as areas within 30 m from Project Site [P-43, P-44, P-45, P-46]. The 30-m impact zone is based on the assumption that edge effects in habitats directly adjacent to worksites are the greatest within 30 m from the worksites. Therefore, to err on the side of caution, a 100-m buffer is applied from the Project Site to obtain the Study Area.
Hydrodynamics	The Study Area for hydrodynamic impact includes the three ponds at Sg. Durian, and the entire southern coast of Pulau Ubin (i.e. Serangoon Harbour).	During operational phase, the proposed development may cause potential changes in current regime (i.e. current speed and direction), pond retention time, as well as other impacts on hydrodynamics, human and habitat within or surrounding the impacted waterbodies such as the three ponds, and the entire southern coast of Pulau Ubin (i.e. Serangoon Harbour), etc.
Water Quality (including sediment plume)	The Study Area for marine water quality impacts and baseline sediment quality is defined as any waterbodies with direct impact from the Project.	<p>During construction phase, the construction activities, increased human activities may cause potential water quality degradation, sediment plume, and other impacts on water quality, human and habitat within or surrounding the impacted waterbodies such as the three ponds, Serangoon Harbour, etc.</p> <p>During operational phase, the increased urbanized area and human activities may cause potential water quality degradation, and other impacts on water quality, human and habitat within or surrounding the</p>

Environmental Impacts	Assessment Area (Construction and Operational Phases)	Justifications
		impacted waterbodies such as the three ponds, Serangoon Harbour, etc.
Morphology	The Study Area for morphological impacts includes the ponds and coastal area in the vicinity of the Project.	During operational phase, the proposed development could permanently change the current regime, leading to potential erosion/sedimentation within the ponds and coastal area in the vicinity of the Project Site, which could further impact on human and habitat within or surrounding the impacted waterbodies such as the three ponds, Serangoon Harbour, etc.
Underwater Noise	The Study Area for underwater noise impacts include the ponds and marine area in the vicinity of the Project.	During construction phase, the construction activities, increased human activities may potentially elevate the underwater noise, which further impact on human and habitat within or surrounding the impacted waterbodies such as the three ponds, Serangoon Harbour, etc.

5.2.2 Identification and Categorization of Sensitive Receptors

Sensitive receptors are those receptors within or in the vicinity of the Project Site which may potentially be impacted by the Project's construction and operational activities. Environmentally sensitive receptors are sub-categorised into three categories: Priority 1, Priority 2 and Priority 3 (from the most sensitive to the least) as shown in the following table. The identification of sensitive receptors for each environmental parameter was developed based on the findings of the environmental reconnaissance surveys, baseline surveys and review of the proposed Project Site.

Table 5-2 Receptor sensitivity classification.

Environmental Parameter	Receptor Sensitivity		
	Priority 1	Priority 2	Priority 3
Biodiversity	Flora, fauna species and habitats of high ecological value (i.e., presence of conservation significant flora, fauna species and habitats; identified keystone species and NParks-designated heritage trees)	Flora, fauna species and habitats of moderate ecological value (i.e., mainly native species of flora, fauna and habitats)	Flora, fauna species and habitats of low ecological value (i.e., mainly exotic or cryptogenic flora, fauna and habitats; managed vegetation which can provide habitat for significant species)
Hydrodynamics	Human Receptors		
	<ul style="list-style-type: none"> Residential developments or high-value industrial or agricultural developments in the vicinity of waterbodies without any flood mitigation measures Structures and facilities whose processes require specific, 	<ul style="list-style-type: none"> Residential developments or high-value industrial or agricultural developments in the vicinity of waterbodies with implemented flood mitigation measures Any other development where human activities would be changed short-term and/or 	<ul style="list-style-type: none"> Non high-value industrial or agricultural developments in the vicinity of the waterbodies Any other development in the vicinity of the watercourse where human activity will not be affected by changes in hydrodynamics

Environmental Parameter	Receptor Sensitivity		
	Priority 1	Priority 2	Priority 3
	<p>predefined volumes and/or temporal distribution of surface water (e.g. hourly, daily)</p> <ul style="list-style-type: none"> Any other development where human activity would be changed long-term, severely altered or completely prevented due to changes in existing hydrodynamics 	<p>moderately altered due to changes in existing hydrodynamics</p>	
	Ecological Receptors		
	<ul style="list-style-type: none"> Habitats and/or biocenosis of high ecological value that require certain quantities of surface water for normal functioning Habitats and/or biocenosis of high ecological value that could be flooded due to changes in existing hydrodynamics which would cause severe and/or long-term disturbances in their functioning 	<p>Habitats and/or biocenosis of high ecological value that could be flooded due to changes in existing hydrodynamics which would cause moderate and/or short-term disturbances in their functioning</p>	<p>Habitats and/or biocenosis that are not of high ecological value and that will not be flooded or disturbed due to changes in existing hydrodynamics</p>
	Water-dependent Socio-Economic Receptors		
	<ul style="list-style-type: none"> Areas of historical or any other conservation significance Areas of national interest (e.g. government buildings, facilities, etc) Areas of major anchorage, frequently used or important for safety Conflicts with major passenger ferry route Recognised international shipping lane Exclusion areas 	<ul style="list-style-type: none"> Areas used for recreational purposes Conflicts with or restricts access to important anchorage Recognised shipping lanes or military practices/exercise area 	<p>Areas of low intensity commercial shipping</p>
Water Quality	Human Receptors		
	<ul style="list-style-type: none"> Humans or entities (e.g. companies, facilities) that use water for beneficial purposes (i.e. drinking purposes or irrigation) Industrial or agricultural developments that require water of high-quality or water with particular physico-chemical characteristics 	<ul style="list-style-type: none"> Entities (e.g. companies, facilities) that use water for industrial purposes and do not have special requirements regarding the water quality The waters are designated for secondary contact activities without primary contact activities such as canoeing, kayaking, 	<ul style="list-style-type: none"> Humans or entities (e.g. companies, facilities) within or in the vicinity of the Project Site that do not use water for any beneficial purpose (i.e. drinking or industrial purposes, irrigation) The waters are not designated for any recreational activities.

Environmental Parameter	Receptor Sensitivity		
	Priority 1	Priority 2	Priority 3
	for their processes and activities <ul style="list-style-type: none"> The waters are designated for primary contact recreation including activities where immersion and ingestion are likely and there is a high degree of bodily contact with the water (e.g. swimming, bathing, skiing, wakeboarding, diving, windsurfing, kite surfing, jet skiing, water immersion training, water play by children, etc.) 	boating, sailing, fishing, etc.	
	Ecological Receptors		
	Habitats and/or biocenosis of high ecological value with low tolerance ² to changes in water quality	Habitats and/or biocenosis of high ecological value with medium to high tolerance ² to changes in water quality	Habitats and/or biocenosis within or in the vicinity of the Project Site that are not of high ecological value
	Water-dependent Socio-Economic Receptors		
	Marine waterbodies protected or used for fish farming or that supports ecosystems of biodiversity conservation significance	Marine waterbodies used for recreational purposes, or marine waterbodies with relatively high biodiversity value, but not protected and are not supporting any ecosystems of biodiversity conservation significance	Marine waterbodies not used for any purposes and are not protected
Morphology (for ecological receptors only)	Natural areas such as beaches, intertidal/mudflat bedform, mangroves and other unprotected sections of the coastline	-	Sections of the coastline with coastal protection structures, such as concrete seawalls and stone revetments
Underwater Noise (for ecological receptors only)	Marine fauna that relies on underwater acoustics for survival (e.g. for sensing of surroundings, protection against predation, use for courtship and/or mating) and unable to move away from the source of the noise. Examples include fish farms.	-	Marine fauna which are able to move away from the source of the noise.

² Tolerance to changes in water quality for identified ecological receptors will be determined with biodiversity specialists

5.3 Data Collection and Analysis

Collection of pre-construction environmental baseline data within the Study Area was conducted both from primary sources and secondary sources.

5.3.1 Sample collection and Survey Locations

The sample collection and survey locations were selected for baseline data collection based on their proximity to the project and receptor priority. These locations were confirmed during a site reconnaissance survey. Site visits were undertaken as tabulated in the following Table 5-3.

Table 5-3 Site visits for data collection

Table 5-3	Site Visits
Biodiversity	<p><u>Site reconnaissance survey:</u></p> <ul style="list-style-type: none"> 7th October 2021 1st November 2021 17th December 2021 <p><u>Sampling dates:</u></p> <ul style="list-style-type: none"> Terrestrial surveys: 16th February – 18th March 2021 Marine intertidal surveys: 16th February – 30th March 2021 Camera trapping: 23rd February – 19th April 2021
Marine Water	<p><u>Site reconnaissance survey:</u></p> <ul style="list-style-type: none"> 6th October 2021 <p><u>Hydrodynamics survey dates:</u></p> <ul style="list-style-type: none"> 5th September 2022 – 25th September 2022 11th November 2022 – 26th November 2022 <p><u>Water quality sampling dates:</u></p> <ul style="list-style-type: none"> 9th March 2022 (neap tide) 7th April 2022 (spring tide) 10th June 2022 (neap tide) 15th June 2022 (spring tide) <p><u>Sediment quality sampling dates:</u></p> <ul style="list-style-type: none"> 15th December 2021 9th March 2022 <p><u>Underwater noise survey dates:</u></p> <ul style="list-style-type: none"> 13th December 2022 – 15th December 2022 (2-day monitoring period) 4th January 2023 – 6th January 2023 (2-day monitoring period)

Further information on sample collection and survey locations and parameters is provided in Section 6 (Biodiversity) and Section 7 (Marine Water).

5.3.2 Secondary Data Collection

Additional secondary data was collected from sources including, but not limited to, the following:

- Proposed Master Plan of the Study Area;
- Historical, current and future land uses;

- Construction/operational boundary/footprint/phasing (e.g. CAD drawing format);
- Construction/operational schedule;
- Commercial and recreational activities;
- Aerial photographs;
- Existing biodiversity information;
- Tidal data (water level and current, etc.);
- Weather data (rainfall, wind, humidity, evaporation);
- Existing topographical and bathymetry maps; and
- Catchment and drainage maps.

Further information on secondary data collection is provided in Section 6 (Biodiversity) and Section 7 (Marine Water).

5.4 EIA Assessment Methodology

5.4.1 Prediction of Impacts

Key potential environmental impacts arising from the Project's construction and operational activities were assessed in this EIA. The methodology for the prediction of impacts is as given in Table 5-4 and Table 5-5.

Table 5-4 Methodology for prediction of construction impacts

Environmental Parameter	Predictive Methods	Assessment Criteria	EIA Section
Biodiversity	<p>Qualitative assessment to evaluate the ecological value of the habitats, floral and faunal species recorded within the Study Area. Sensitive receptors within the Study Area which may be impacted by the Project's construction activities will be identified. Sensitive receptors will be sub-categorised into three priority levels according to Table 5-2, depending on their ecological value. Thereafter, a qualitative impacts assessment to evaluate the potential impacts (Table 5-6) from the Project's construction activities on the identified sensitive receptors, taking into consideration the likelihood (Likelihood is estimated on the basis of experience and/or evidence that such an outcome has previously occurred. Impacts resulting from routine/planned events (normal operations) are classified under High Likelihood.</p> <p>Table 5-9) of impact occurrence will be conducted; where the likelihood depends on factors such as duration of impact.</p>	Assessment criteria broadly takes guidance from Hong Kong Environmental Impact Assessment Ordinance - Technical Memorandum Annex 8, with considerations from literature review and local biodiversity standards.	Section 6
Water Quality (including sediment plume)	<p>Qualitative, analytical methods as well as quantitative modelling to assess water quality impacts of construction activities.</p> <p>Qualitative water quality impact assessment was carried out by</p>	<p>For qualitative water quality impact assessment</p> <ul style="list-style-type: none"> • Environmental Protection and Management (Trade Effluent) regulations, Singapore Marine Water Quality Guidelines (MWQG) 	Section 7

Environmental Parameter	Predictive Methods	Assessment Criteria	EIA Section
	<p>considering any related standard minimum controls.</p> <p>Sediment plume modelling was used to assess the impact from suspended solid concentration (SSC) induced from construction phase on the marine water quality. With the sediment plume model, the incremental SSC and its sedimentation rate were predicted compared to the marine baseline levels. The impact on sensitive receptors was assessed based on pre-determined tolerance limits.</p>	<ul style="list-style-type: none"> • Allowable Limits for Trade Effluent Discharge to Watercourse or Controlled Watercourse (NEA) • Singapore Fisheries Act • ASEAN Marine Water Quality Management Guidelines and Monitoring Manual (2008) • Singapore NEA Water Quality Guidelines for Recreational Beaches and Fresh Water Bodies • United States Environmental Protection Agency guideline values for marine waters (USEPA, 2017) <p>For sediment plume impact assessment:</p> <ul style="list-style-type: none"> • Pre-determined tolerance limits for sedimentation rates and suspended solids concentration for selected sensitive receptors such as seagrass, mangrove and aquaculture farms (Appendix M). 	
Underwater Noise	<p>Qualitative and analytical methods were applied to assess underwater noise impacts of the construction phase on marine life.</p> <p>Assessment was conducted by using estimated underwater noise levels from literature that are specific to the proposed construction activities and equipment used, and to compare against the guidelines/criteria for aquatic fauna (e.g. marine mammals, fish and invertebrates).</p>	<ul style="list-style-type: none"> • Committee S3/SC 1 Sound Exposure Guidelines for Fishes and Sea Turtles: A Technical Report (2014) • United Nations CMS Technical Support Information to the CMS Family Guidelines on EIA for Marine Noise-generating Activities (2017) • US NOAA Technical Guidance for Assessing the Effects of Anthropogenic Sound on Marine Mammal Hearing: Underwater Thresholds for Onset of Permanent and Temporary Threshold Shifts (2018) • EC Marine Strategy Framework Directive (revised 2017) 	Section 7

Table 5-5 Methodology for prediction of operational impacts

Environmental Parameter	Predictive Methods	Assessment Criteria	EIA Section
Biodiversity	<p>Qualitative assessment to evaluate the ecological value of the habitats, floral and faunal species recorded within the Study Area. Sensitive receptors within the Study Area which may be impacted by the</p>	<p>Assessment criteria broadly takes guidance from Hong Kong Environmental Impact Assessment Ordinance - Technical Memorandum Annex</p>	Section 6

Environmental Parameter	Predictive Methods	Assessment Criteria	EIA Section
	<p>Project's operational activities will be identified. Sensitive receptors will be sub-categorised into three priority levels according to Table 5-2, depending on their ecological value. Thereafter, a qualitative impacts assessment to evaluate the potential impacts (Table 5-6) from the Project's operational activities on the identified sensitive receptors, taking into consideration the likelihood (Likelihood is estimated on the basis of experience and/or evidence that such an outcome has previously occurred. Impacts resulting from routine/planned events (normal operations) are classified under High Likelihood.</p> <p>Table 5-9) of impact occurrence will be conducted; where the likelihood depends on factors such as duration of impact.</p>	<p>8, with considerations from literature review and local biodiversity standards.</p>	
<p>Hydrodynamics</p>	<p>Quantitative methods were applied to assess hydrodynamics impact of the development operational phase.</p> <p>Quantitative hydrodynamic (e.g. current speed/direction and flow pattern) modelling was conducted to simulate potential impact of hydrodynamic changes to identified sensitive receptors due to the proposed development, such as navigation impacts. The impact on sensitive receptors was assessed based on pre-determined tolerance limits.</p>	<p>Pre-determined tolerance limits (Appendix M)</p>	<p>Section 7</p>
<p>Water Quality</p>	<p>Qualitative and analytical methods to assess water quality impacts of operational activities.</p> <p>Qualitative water quality impact assessment was carried out by considering any related standard minimum controls.</p>	<ul style="list-style-type: none"> • Environmental Protection and Management (Trade Effluent) regulations, Singapore Marine Water Quality Guidelines (MWQG) • Allowable Limits for Trade Effluent Discharge to Watercourse or Controlled Watercourse (NEA) • Singapore Fisheries Act • ASEAN Marine Water Quality Management Guidelines and Monitoring Manual (2008) • Singapore NEA Water Quality Guidelines for Recreational Beaches and Fresh Water Bodies • United States Environmental Protection Agency guideline values for marine waters (USEPA, 2017) 	<p>Section 7</p>

Environmental Parameter	Predictive Methods	Assessment Criteria	EIA Section
Morphology	<p>Quantitative and analytical methods were applied to assess morphological impacts of the development operational phase.</p> <p>Morphological modelling was conducted to assess the coastal morphological impacts of the proposed development in long-term duration.</p>	Pre-determined tolerance limits (Appendix M)	Section 7

5.4.2 Evaluation of Impacts

Key potential environmental impacts arising from the proposed Project and significance of impacts will be assessed using the methodology described in the following sections.

In evaluating the Significance of impacts, the following factors will be taken into consideration:

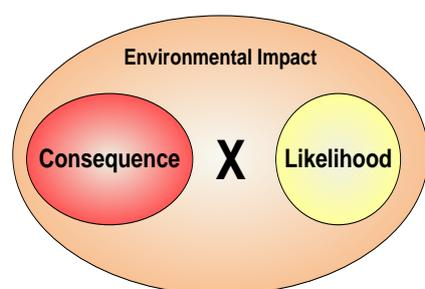

- **Impact Consequence:** The consequence of an impact is a function of a range of considerations including impact spread, impact duration, impact intensity and nature, legal and guideline compliance.
- **Likelihood of Occurrence:** The likelihood of the impact occurring in life of the project.

5.4.2.1 Impact Consequence

In evaluating the consequence of environmental impacts, the following aspects were taken into consideration:

- **Receptor Sensitivity:** categorises receptors according to their susceptibility to adverse impacts from the Projects construction and operational phases (refer to Table 5-2);
- **Impact Intensity:** defines the magnitude of the impact and the status of the impact in relation to regulations (e.g. discharge limits), standards (e.g. environmental quality criteria) and guidelines. The criteria presented in Table 5-6 and Table 5-7 was used to categorise the impact intensity.

Table 5-6 Evaluation of impact intensity for construction phase.

Environmental Parameters	Impact Intensity			
	Negligible	Low	Medium	High
Biodiversity- Habitats	Refer to Table 6-13, Table 6-15 and Table 6-17 for Habitats, Flora and Fauna definition respectively.			
Biodiversity – Flora and Fauna	No expected changes to the ecologically sensitive receptors and/or individuals	Short duration and small-scale localised spatial changes that could cause minimal changes to the ecologically sensitive	Moderate duration and medium-scale spatial changes that could cause moderate effects on the ecologically sensitive receptors but would not	Extended duration and large-scale spatial changes that could cause substantial effects on the ecologically sensitive receptors and

Environmental Parameters	Impact Intensity			
	Negligible	Low	Medium	High
		receptors and/or individuals	threaten long-term viability	threaten long-term viability
Water Quality (including sediment plume)	No contamination; or Likely to be well within regulatory limits. The incremental SSC refers to pre-determined tolerance limits as in Appendix M.	Small scale localised contamination within regulatory limits. The incremental SSC refers to pre-determined tolerance limits as in Appendix M.	Medium scale contamination just exceeds regulatory limits. The incremental SSC refers to pre-determined tolerance limits as in Appendix M.	Large scale contamination exceeds regulatory limits. The incremental SSC refers to pre-determined tolerance limits as in Appendix M.
Underwater Noise	No detectable change to flora, fauna and habitats.	Potential impacts last a short duration, are reversible and/or of a small magnitude for species with low auditory sensitivity level.	Potential impacts last for a moderate duration, are reversible with significant input and compensatory measures, and/or of a moderate magnitude for species with auditory sensitivity level.	Potential impacts last for a long time, are non-reversible, and/or of a significant magnitude for species with high auditory sensitivity level.
<p>Notes:</p> <ol style="list-style-type: none"> The Flora & Fauna Specialist will be consulted to identify the species sensitivity to the potential change to their habitat, conservation status and foraging regime. 				

Table 5-7 Evaluation of impact intensity for operational phase.

Environmental Parameters	Impact Intensity			
	Negligible	Low	Medium	High
Biodiversity- Habitats	Refer to Table 6-23 and Table 6-25 for Habitats and Fauna definition respectively.			
Biodiversity – Flora and Fauna	No expected changes to the ecologically sensitive receptors and/or individuals	Short duration and small-scale localised spatial changes that could cause minimal changes to the ecologically sensitive receptors and/or individuals	Moderate duration and medium-scale spatial changes that could cause moderate effects on the ecologically sensitive receptors but would not threaten long-term viability	Extended duration and large-scale spatial changes that could cause substantial effects on the ecologically sensitive receptors and threaten long-term viability
Hydrodynamics	No detectable change on flow velocity within	Small scale localised changes to representative	Medium scale changes to representative	Large scale changes to representative

Environmental Parameters	Impact Intensity			
	Negligible	Low	Medium	High
	pre-determined tolerance limits as in Appendix M.	current speeds and direction within pre-determined tolerance limits as in Appendix M.	current speeds and direction within pre-determined tolerance limits as in Appendix M.	current speeds and direction within pre-determined tolerance limits as in Appendix M.
Water Quality (excluding sediment plume)	No contamination; or Likely to be well within regulatory limits.	Small scale localised contamination within regulatory limits.	Medium scale contamination just exceeds regulatory limits.	Large scale contamination exceeds regulatory limits.
Morphology	No detectable change to morphology.	Small scale, and localised changes to bedform and shoreline morphology.	Medium scale changes to bedform and shoreline morphology.	Large scale changes to bedform and shoreline morphology.
Notes: 1. The Flora & Fauna Specialist will be consulted to identify the species sensitivity to the potential change to their habitat, conservation status and foraging regime.				

A consequence category is then derived based on receptor sensitivity and impact intensity, as shown in Table 5-8.

Table 5-8 Impact consequence matrix.

Sensitivity \ Impact Intensity	Priority 3	Priority 2	Priority 1
Negligible	Imperceptible	Imperceptible	Very Low
Low	Very Low	Very Low	Low
Medium	Very Low	Low	Medium
High	Low	Medium	High

5.4.2.2 Likelihood

Likelihood is estimated on the basis of experience and/or evidence that such an outcome has previously occurred. Impacts resulting from routine/planned events (normal operations) are classified under High Likelihood.

Table 5-9 Likelihood criteria.

Likelihood Criteria	Definition for All Environmental Parameters
Unlikely/ Remote	Would be unlikely or not expected to occur during construction and operational activities.
Less Likely/ Rare	Would less likely/ rarely occur during construction and operational activities.
Possible/ Occasional	Would possibly/ occasionally occur during construction and operational activities.
Likely/ Regular	Would likely to occur or would occur on a regular basis during construction and operational activities.
Certain/ Continuous	Would be certain to occur or would occur continuously during construction and operational activities.

Likelihood Criteria	Definition for All Environmental Parameters
References:	
<ol style="list-style-type: none"> 1. Ecological Impact Assessment (EclA). EIANZ Guidelines for use in New Zealand: terrestrial and freshwater ecosystems. 2nd Edition. May 2018. [R-29] 2. CIEEM (2018). Guidelines for ecological impact assessment in the UK and Ireland: Terrestrial, Freshwater and Coastal. September 2018. [R-30] 	

5.4.2.3 Impact Significance

The significance of each impact will be determined by assessing the impact consequence against the likelihood of the impact occurring using the Impact Significance Assessment Matrix. A simple risk-based matrix will be used for summation of consequence and likelihood, a sample of which is shown below.

Table 5-10 Impact significance matrix.

Consequence Likelihood	Imperceptible	Very Low	Low	Medium	High
Unlikely/ Remote	Negligible	Negligible	Negligible	Negligible	Negligible
Less Likely/ Rare	Negligible	Negligible	Minor	Minor	Minor
Possible/ Occasional	Negligible	Minor	Minor	Moderate	Moderate
Likely/ Regular	Negligible	Minor	Moderate	Moderate	Major
Certain/ Continuous	Negligible	Minor	Moderate	Major	Major

Positive impacts are classified under a single category. Impacts assessed as negligible or minor will require no additional management or mitigation measures (on the basis that the magnitude of the impact is sufficiently small, or that the receptor was of low sensitivity and/or that adequate controls were already included in the Project design). Negligible and minor impacts are therefore deemed to be “Insignificant”. Impacts evaluated as moderate or major require the adoption of management or mitigation measures. Major impacts are therefore deemed to be “Significant” and moderate impact as “Relatively Significant”. Major impacts always require further management or mitigation measures to minimise or reduce the impact to an acceptable level.

An “acceptable level” is the reduction of a major impact to a moderate one after mitigation. In seeking to mitigate moderate impacts, the emphasis is on demonstrating that the impact has been reduced to a level that is as low as reasonably practicable. It will not always be practical to reduce moderate impacts to minor ones in consideration of the cost-ineffectiveness of such an approach (due to the diminishing return of a reduction of impact versus cost). Residual impact assessment shall be conducted for those parameters where impact from the activity is identified to be significant and additional mitigation measures are recommended. Positive impacts were not assessed for significance. Assessment of residual impact shall follow similar risk approach as outlined above.

5.5 Mitigation of Impacts and Environmental Monitoring and Management Plan (EMMP)

Where the implementation of minimum controls is insufficient to alleviate any significant environmental construction and operational impacts (moderate to major impacts), Project-specific final mitigation measures, in consultation with NParks, were proposed. Where applicable and practical, engineering control measures were accompanied by specifications (product brochures), estimated cost and source of supply. In addition, mitigation measures at receptors’ end were recommended on a case-by-case basis. For example, if the unmitigated suspended solid concentrations in the ponds during construction are found to exceed the relevant criteria, practical direct mitigation measures such as the use of silt screens, silt curtains, silt fences and erosion control blankets, etc. will be recommended. Mitigation measures were proposed in accordance with the following hierarchy in line with Biodiversity Impact Assessment (BIA) Guidelines published by NParks in year 2020 [R-9]:

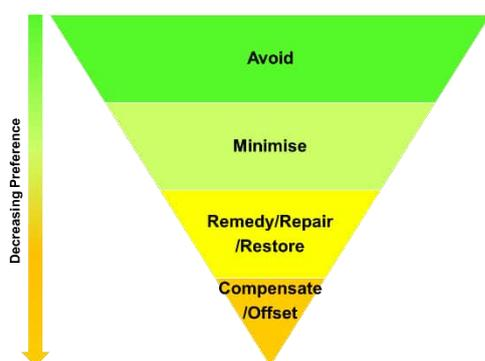

Figure 5-2 Mitigation hierarchy.

- **Avoid** – Where changes to the Project design and construction/operation methodology can be made to eliminate or avoid an identified impact (e.g. optimisation or reduction of construction footprint, shift or elimination of construction site in critical areas, etc.). If a full elimination is not possible, the next level of mitigation is to minimise the identified impact.

- **Minimise** – Where changes to the Project design and construction/operation methodology cannot affect impact elimination or avoidance, use of alternative construction methodology or any enhancement measures can be adopted to minimise for identified impacts. For e.g. a wildlife shepherding plan is put in place to allow any animals trapped on the site to escape into the surrounding vegetation.

- **Remedy/Repair/Restore** – Where changes to the Project design and construction/operation cannot affect impact avoidance and impact minimisation, restoration methodology can be applied after construction is completed to remedy/repair/restore the ecological habitat as much as possible.

- **Compensation/Offset** – Where measures taken to compensate or offset the residual impacts after implementing the first three steps of the mitigation hierarchy, wherever technically and financially feasible, e.g. transplanting of rare shrubs or trees to elsewhere in consultation with government authorities, etc.

Subsequently, a Construction and Operational Stage EMMP was formulated specifying mitigation measures, monitoring scope, methodology and location, and triggers to report and escalate the irregularities in the baseline conditions at construction and operational stages.

5.6 Evaluation of Cumulative Impacts

As described in Section 3.10, there are other concurrent construction activities planned in the vicinity of the Project. The cumulative impacts of these concurrent developments will be assessed qualitatively in each individual section of different environmental disciplines.

5.7 Stakeholder and Public Engagements

It is known that effective communication and cooperation between various expert and interest groups, stakeholders as well as the Client or stakeholders will definitely minimise any risks throughout the project delivery process.

As such, during the project period, stakeholders (e.g. FUN and R.U.M.), expert groups and Agencies were engaged to share their feedback and suggestions on both the project design and the scope of works for this EIA. This will be detailed in Section 9.

6 Biodiversity

6.1 Introduction

The Biodiversity Impact Study aims to establish baseline biodiversity information of the Study Area (as defined in Section 5.2.1) and evaluate the impacts of the proposed project on existing biodiversity resources. Baseline information was first gathered through reviews of past and present biodiversity records, published literature, and in consultation with taxonomic experts. Field surveys were then carried out to verify and supplement the data. Through desktop and field assessments, important habitats as well as floral and faunal species of conservation significance were identified. The information was then used to evaluate the nature and scale of potential impacts associated with the project. Mitigation measures were recommended to avoid, reduce and/or minimise identified impacts.

6.2 Methodology

6.2.1 Desktop Research

The Biodiversity Baseline Study aims to establish baseline information of the Study Area, necessary for future evaluations, in monitoring and assessing potential impacts of developments on existing flora and fauna. Baseline information were gathered through reviews of past and present biodiversity records and published literature. Actual field surveys were then carried out to verify and supplement the data, in consultation with taxonomic experts. Through desktop and field assessments, important habitats, species of flora and fauna of conservation significance were identified.

6.2.1.1 Land Use History

Historical and present-day land use of the Project Site were reviewed. Information on land use history were primarily be gathered from old maps in the online collection of the National Archives of Singapore (NAS) [M-1] as well as historical maps on the OneMap [M-3] and the NUS Libraries portals [M-2]. A list of notable faunal species (namely conservation significance and other ecologically important species) was generated using information on past faunal records and existing habitat types for the Project Site.

6.2.1.2 Taxonomy and Nomenclature

Past and present floristic as well as faunistic species composition were examined using relevant key references that include books, scientific publications, unpublished literature, and online databases. Sources of databases include The Biodiversity of Singapore by the Lee Kong Chian Natural History Museum [W-4], Flora and Fauna Web by the National Parks Board [W-5] and iNaturalist [W-2]. Other key references include the Singapore Red Data Book [P-8], Singapore Biodiversity Records [W-6], encyclopedia on Singapore's biodiversity [P-19] and the database of flora and fauna records compiled by AECOM.

Key local and/or regional references for the various taxonomic groups are listed in the Table 6-1 below.

Table 6-1 Key references for the nomenclature and taxonomy for each taxonomic group.

Taxon	Key References
Plants	Lindsay et al., 2022 [P-71]; Chong et al., 2009 [P-5]; Chong et al., 2009 [P-5]; World Checklist of Selected Plant Families [W-8]; Plants of the World Online [W-7].
Odonates	Tang et al., 2010 [P-27]; Ngiam & Cheong, 2016 [P-16]; Soh and Ngiam, 2019 [P-24].
Butterflies	Khew, 2015 [P-12]; Jain et al., 2018 [P-11]; Theng et al., 2020 [P-29]
Aculeate hymenopterans	Soh and Ngiam, 2013 [P-23]; Ascher and Pickering, 2018 [P-1]; Soh and Ascher, 2020 [P-22].
Herpetofauna	Baker and Lim, 2012 [P-2].
Birds	Gill and Donsker, 2021 [W-3]; Singapore Birds [W-9]; Singapore Bird Group [W-10]; Singapore Birds Project [W-11].

Taxon	Key References
Mammals (including bats)	Corlett, 1992 [P-7]; Teo & Rajathurai, 1997 [P-28]; Brook et al., 2003 [P-3]; Lane et al., 2006 [P-14]; Chua & Lim, 2011 [P-6]; Baker and Lim, 2012 [P-2].
Fish	Ng & Lim (1997) [P-18]; Kottelat (2013) [P-13]; Ho et al. (2016) [P-10]; Tan et al. (2020) [P-26]; Giam et al. (2011) [P-9].
Decapoda and molluscs	Ng, 1997 [P-17]; Cai et al., 2007 [P-4], Wowor & Ng, 2010 [P-30]; Yeo, 2010 [P-34]; Ho et al., 2016 [P-10]; World Register of Marine Species [W-15].

6.2.1.3 Species of Conservation Significance

The assessment of whether certain species are of conservation significance is important for highlighting priorities for conservation. For flora species, Chong et al. (2009) [P-5] acts as a primary reference, where plants are listed as nationally Vulnerable, Endangered, Critically Endangered, or Presumed Extinct. As a general guideline, the assessment of a threatened plant species' conservation significance is based on, but not limited to, the following information: (1) land-use history, (2) presence of large parent tree(s), (3) commercial availability, (4) data from previous environmental impact assessments, (5) reforestation efforts, (6) natural range, and (7) importance for associated fauna.

Faunal species of conservation significance, on the other hand, include both notable (often non-threatened species) and threatened species. Notable species are fauna species that provide important areas, such as breeding sites and play other keystone roles in the ecosystem. Or are deemed to be sensitive to construction impacts. Threatened faunal species are those listed as nationally or globally Vulnerable, Endangered, Critically Endangered, or Extinct, with reference to the Singapore Red Data Book (SRDB) [P-8] or other recent checklists, such as Soh et al. 2019 [P-24] for odonates and Jain et al. 2018 [P-11] for butterflies, and the Red List of Threatened Species by the International Union for Conservation of Nature (IUCN, 2012 [R-7]).

6.2.2 Field Assessment

6.2.2.1 Site Reconnaissance

Site reconnaissance surveys was conducted to obtain an initial understanding of the existing habitats and biodiversity. Field observations were used for the planning and execution of the actual surveys. The objectives of the reconnaissance survey were as follow:

- Determine site accessibility and terrain
- Conduct a preliminary assessment to determine the dominant vegetation types
- Identify locations of existing natural permanent waterbodies, such as streams, ponds, and swampy areas (if any)
- Mark out survey sampling routes and potential locations for camera traps

6.2.2.2 Flora Field Assessment

The field assessment for flora consists of habitat and vegetation mapping. Flora field assessment were carried out from November 2021 over a period of four months.

6.2.2.2.1 Habitat and Vegetation Mapping

A preliminary vegetation map for the Study Area (Figure 6-1) was first prepared based on visual interpretations of satellite images from Google Earth 7.1.2.2041 (Google Inc. 2013 [O-1]). Preliminary classification of the vegetation types — for example, scrubland and forest — was determined using visual features, such as textures and colours, observed in the satellite images. Adjustments were then be made to the preliminary maps according to actual observations during ground truthing. Ground truthing was conducted throughout the survey area with the aid of a GPS receiver (Garmin GPSMap® 64s). Photographs of the vegetated areas were also be taken. The boundaries of each vegetation type were tracked on the GPS receiver and mapped out on Google Earth 7.1.2.2041. The classification of vegetation types references NParks [R-9].

For plants that cannot be immediately identified with certainty in the field, photographs and/or voucher specimens were taken. They were then identified using identification keys, taxonomic descriptions, online plant photo databases, with the help of taxonomic experts, and/or by matching the pressed and dried collected specimens with existing specimens in the Singapore Botanic Gardens' Herbarium (SING).

6.2.2.2 General Walking Floristic Surveys

All plants observed in the Study Area during floristic surveys were identified to species whenever possible. A checklist of all the plant species recorded from the present floristic surveys were compiled. The nomenclature and national conservation status follow that of Chong et al. (2009) [P-5], and/or other published papers with information on the updated assessment of the species nomenclature and/or conservation status. The latter is usually for one or a few individual species. Other information on the plant species was also cross-checked with online databases, namely, the National Parks Board Flora and Fauna Web and Singapore Biodiversity Online.

For plants that could not be immediately identified with certainty in the field, photographs and/or voucher specimens were taken. They will then be identified using identification keys, taxonomic descriptions, online plant photo databases, with the help of taxonomic experts, and/or by matching the pressed and dried collected specimens with existing specimens in the Singapore Botanic Gardens' Herbarium (SING).

For very tall unidentifiable trees with leaves that are too high in the canopy to photograph, dried leaves matching these trees were collected from the forest floor and used to aid in species identification.

Species of Conservation Significance

The geographic coordinates of plants of conservation significance were marked using a Global Positioning System (GPS) receiver (Garmin GPSMap® 64s), which records locations with an accuracy of ± 4 m, during floristic surveys. Where there were clusters of plants of conservation significance—i.e., more than one individual occurring within 5 m or less of another individual—the geographic coordinates of the approximate centre of the area were marked using the GPS receiver.

Large Plant Specimens

Similarly, the GPS receiver were used to record locations of all trees of ≥ 3 m girth, as well as bamboo clusters, palm clusters, and strangling *Ficus* species of ≥ 3 m spread. Individuals will be identified to species and whenever possible, measure girth (for trees)/estimate spread (for bamboo clusters, palm clusters, and strangling *Ficus* species), estimate height and tag them with unique serial numbers.

Other Plant Specimens of Value

Locations of other plants that are of value but do not meet the minimum size requirement, as detailed in the above sub-section, were also recorded using the GPS receiver. Examples of such include bamboo clusters of < 3 m spread that may be important refugia for rare bamboo bats, amongst others.

6.2.2.3 Faunal Field Assessment

Faunal field surveys were carried out for the following taxa: (1) butterflies, (2) odonates (damselflies and dragonflies), (3) herpetofauna (amphibians and reptiles), (4) birds, (5) mammals (including bats), and (6) marine fauna (fish, decapod, and molluscs). All observations of notable species from the aforementioned taxa were also recorded if seen outside the stated survey times.

The routes, locations and number of sampling units were finalised upon completion of all site reconnaissance surveys (Figure 6-1).

Table 6-2 summarises all the surveys that were carried out for this project. Each survey was performed by at least two surveyors. All fauna encountered was identified to species, or to the lowest taxonomic level possible, and the location of each individual was recorded using a handheld GPS (Garmin GPSMAP 64s). The number of individuals observed was also documented.

Table 6-2 Summary of flora and faunistic surveys.

Survey Type	Taxon	Timing (h)	Duration and Frequency	Sampling Unit	Equipment deployed in the field	Technique
Habitat Mapping	Flora	Daytime	As many as needed	–	–	Identification of all plants within site
General Walking Flora Surveys						
Diurnal Transect Surveys	Butterflies	0900–1200	20–30 minutes per transect; 2 replicates	200-m continuous transects along the sampling route(s)	Flagging tape to mark out transect route; removed at end of study	Visual only; up to 25 m left, right, and front of surveyor
	Odonates (damselflies and dragonflies)	0900–1200				
Diurnal and Nocturnal Transect Surveys	Herpetofauna (amphibians and reptiles)	0700–1000; 2000–2300	20–30 minutes per transect; 2 replicates	200-m continuous transects along the sampling route(s)	Flagging tape to mark out transect route; removed at end of study	Visual and auditory; up to 50 m left, right, and front of surveyor
	Birds	0700–1000; 2000–2300				
	Mammals (non-volant)	0700–1000; 2000–2300				
Camera Trapping	Mammals (non-volant)	24 hours a day	60 days; once throughout the study	Traps spaced at least 200 m apart	Camera trap and flagging tape to mark out camera trap locations; removed at end of study	Infrared motion sensing
Bioacoustics Surveys	Mammals (bats)	2000–2300	20–30 minutes per transect; 2 replicates	200-m continuous transects along a sampling route	–	Auditory only
Harp Trapping	Mammals (bats)	1930 (Day 1)–0800 (Day 2)	Overnight	Harp traps	Harp traps to be deployed overnight	–
Mist Netting	Mammals (bats)	1930–0000	Overnight	Mist nets	–	–
#Cast Netting	Fish	Daytime	Twice during the study period	Casts performed	Cast net	–
#Seine Netting	Fish	Daytime	Twice during the study period	Seine net sessions performed	Seine net	–

Survey Type	Taxon	Timing (h)	Duration and Frequency	Sampling Unit	Equipment deployed in the field	Technique
Quadrat Sampling	Fish, decapoda, and molluscs	During low tide periods (0–0.5 m)	Twice during the study period	50 x 50 cm quadrats	–	Benthic fauna survey
<p>Note: # denotes that either seine netting or cast netting will be carried out for surveying of fish</p>						

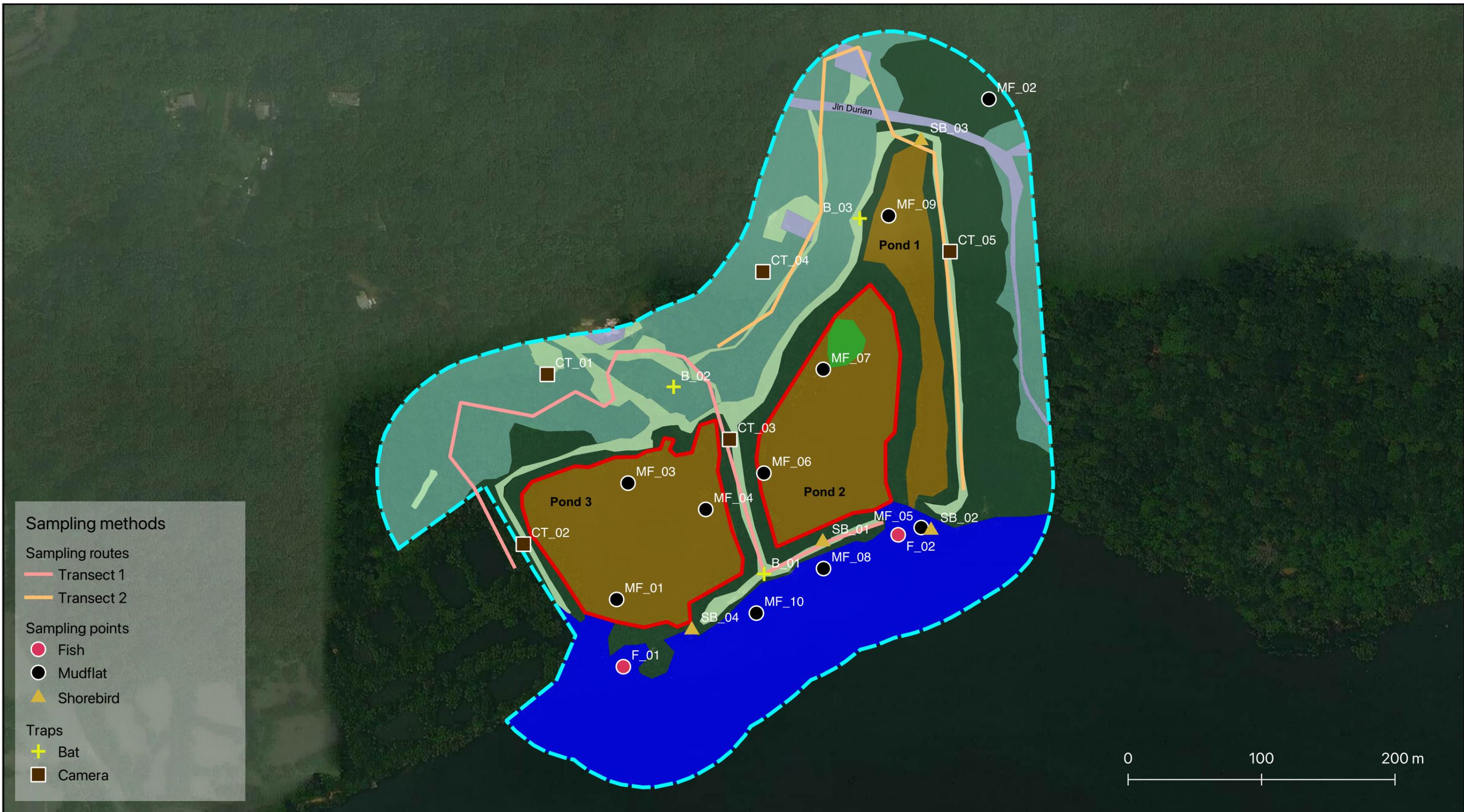

Sampling methods

Sampling routes

- Transect 1
- Transect 2

Sampling points

- Fish
- Mudflat
- Shorebird

Traps

- Bat
- Camera

Legend

- Filled Area
- Overall EIS Study Area
- Mangrove
- Seagrass
- Abandoned-land forest
- Scrubland
- Soft sediment seabed
- Marine area
- Infrastructure

Rev. Date By Description Chk'd App'd

- DEC 2022 SS EIA Report NHT JAG

Rev.	Date	By	Description	Chk'd	App'd
-	DEC 2022	SS	EIA Report	NHT	JAG

Qualified Person Endorsement : NA

NParks Endorsement : NA

Consultant : **AECOM**

Project Title :
**CONTRACT NPARKS/N/39/2017
 CONSULTANCY SERVICES FOR SHORELINE
 WORKS IN PULAU UBIN
 (MANGROVE RESTORATION OF
 SUNGEI DURIAN PONDS)**

Designed SS	Checked NHT	Approved JAG
Drawn SS	Date DEC 2022	

Client:

Figure Title:
Location of terrestrial and aquatic sampling units

Figure No. : 6-1

Rev. : -

Sheet : 1 of 1

CAD File Name : NA

A3

6.2.2.3.1 Butterflies

Diurnal transect surveys were carried out for adult butterflies along 200-m continuous transects on a sampling route (Figure 6-1) between 0900h and 1200h. Butterfly caterpillars, pupae, eggs, and host plants were also recorded when observed. Adult butterflies were identified visually (with binoculars where necessary), photographed, or caught using insect nets if required. Captured individuals were released immediately after identification.

6.2.2.3.2 Odonates (Dragonflies and Damselflies)

Diurnal transect surveys were carried out for adult damselflies and dragonflies along 200-m continuous transects on a sampling route (Figure 6-1) between 0900h and 1200h. Owing to difficulties in sampling and identification, aquatic larvae and exuviae were not surveyed. Adult odonates were identified visually (with binoculars where necessary), photographed or caught using insect nets if required. Captured individuals were released immediately after identification.

6.2.2.3.3 Herpetofauna (Amphibians and Reptiles)

Diurnal (0700h–1000h) and nocturnal (2000h–2300h) surveys were carried out for amphibians and reptiles along 200-m continuous transects on a sampling route (Figure 6-1). As herpetofauna occupy a wide range of habitat types, both the diurnal and nocturnal surveys also involved active searches for individuals on the ground, below rocks, logs, leaf litter and debris, in the water, and/or on vegetation. Torches and/or headlamps were used to elicit eyeshine during nocturnal surveys. Vocalising fauna were also located or identified by call recognition, whenever possible. For species that are capable of quick retreats and escapes, the individuals were captured by hand, or using hooks, tongs, or dip nets for identification. Captured individuals were released immediately after identification.

6.2.2.3.4 Birds

Diurnal (0700h–1000h) and nocturnal (2000h–2300h) surveys were carried out for birds along 200-m continuous transects on a sampling route (Figure 6-1). Birds were identified visually (with binoculars where necessary) and photographed. Torches and/or headlamps were used to elicit eyeshine during nocturnal surveys. Vocalising birds were also located or identified by call recognition, whenever possible.

Targeted point counts were carried out for migratory shorebirds at two (2) locations (Figure 6-1). Point counts were conducted at low tide levels between 0.0–0.5 m, and during daylight hours. Birds were identified visually (with binoculars or spotting scopes where necessary) and photographed, when possible. At each point, all shorebirds visible from the point will be identified and recorded.

6.2.2.3.5 Mammals (Non-Volant)

Diurnal (0700h–1000h) and nocturnal (2000h–2300h) surveys were carried out for non-volant mammals along 200-m continuous transects on a sampling route (Figure 6-1). Both the diurnal and nocturnal surveys also involved searches in burrows and tree holes. Tracks, scats and holts were also recorded. Mammals were identified visually (with binoculars where necessary) and photographed. Torches and/or headlamps were used to elicit eyeshine during nocturnal surveys. Vocalising mammals, such as the squirrels, were also located or identified by call recognition, whenever possible.

In addition to transect surveys, mammals were also surveyed via camera trapping (Figure 6-2). This method is useful for the survey of terrestrial (mostly ground dwelling) mammals because it is non-invasive (i.e., does not require capturing and handling of animals), not labour-intensive, and can be programmed to operate 24 hours a day. This allows for both diurnal and nocturnal species to be recorded, especially if their peak activity periods do not overlap with the timings of transect surveys.

Five terrestrial camera traps were deployed for the Study Area, in the areas around the disused ponds. The camera traps were deployed at least 200 m apart within the Study Area and kept at least 20 m away from the transects, whenever possible. They were also stratified across sites to cover all vegetation types. Locations of the camera traps were finalised upon completion of all site reconnaissance surveys.

Each camera trap was set up at approximately 20–30 cm above ground (Figure 6-2). They operated 24 hours a day and were programmed to record 10-second footage per motion trigger with a 10-second quiet period following each trigger. Each camera trap was deployed for 60 days.



Figure 6-2 Example of a camera trap setup.

6.2.2.3.6 Mammals (Bats Only)

Acoustics surveys were carried out for bats along 200-m continuous transects on a sampling route (Figure 6-1) between 2000h and 2300h. The Echo Meter Touch 2 Pro (Wildlife Acoustics, Inc.) were used to record, stream, and attenuate ultrasonic calls between 18 and 192 kHz at a sampling frequency of 384 kHz to low frequency signals below 20 kHz, a range that is audible to the human ear.

Live trapping was carried out for bats. This comprises harp trapping (1930h on Day 1 to 0800h on Day 2) and mist netting (between 1930h and 0000h on Day 1). Harp trapping targets smaller insectivorous bats, while mist netting targets larger fruit and/or nectar bats. Up to three harp-trap-and-mist-net pairs were set up on the same day, where each pair were set up close to each other at suitable locations (Figure 6-1 and Figure 6-3). The traps and nets were checked every 30 minutes throughout the night on Day 1. The survey set consisting of three harp traps and three mist nets were repeated once on a different day at a different location. All trapped bats were identified and released immediately. Simultaneously, bamboo bat roost emergence surveys were carried out at identified bamboo clusters within the Study Area (between 1830h and 2100h). Bamboo bats were identified visually and photographed, and calls were recorded using the Echo Meter Touch 2 Pro detector. Bamboo slits that are at least 1 cm wide and long and are actively used for entry and exit, as well as the number of bats residing within each internode were recorded.



Figure 6-3 Photographs showing examples of A) canopy mist net and (B) ground harp trap deployed during bat trapping.

6.2.2.3.7 Marine Fauna (fish, decapoda and molluscs)

Surveys were carried out during low tide when seawater levels were 0.3 m or less. Quadrat sampling and visual surveys were conducted in both mudflat and intertidal habitats to sample benthic species. Specifically chosen points include those at the mouth of the disused ponds (locations where sediments will leave if there is an erosion of the sediment piles) or areas at or near the presently proposed sediment pile sites (Figure 6-1).

Transects were set up and positioned to overlap with different habitat sub-types in the Study Area as much as possible. Depending on whether the area is a mudflat or an intertidal area, transect lengths were set at 15m and 50m respectively. Quadrats measuring 50 × 50 cm were set up at three randomly generated points along the transects. It was ensured that each mudflat quadrat is spaced at least 1 m apart, and each intertidal quadrat is spaced at least 5m apart, and in an alternate left-right arrangement (Figure 6-4A). Upon setting up a quadrat, all visible fauna on the mud surface were first identified and counted. Thereafter, mud up to a maximum depth of 15 cm were dug out from the quadrat and sieved using a mesh to filter out all benthic fauna. These was repeated for all three quadrats along the transect.

Additional visual surveys were only carried out in mudflat habitats (Figure 6-4B). Using the 15-m transect as the reference diameter, a circular survey zone was sampled for other more mobile fauna not recorded during quadrat sampling, such as decapoda (crustaceans). The visual surveys were carried out by at least one surveyor over a period of 10 minutes per circular zone.

Either cast or seine netting was carried out at specific points along the shoreline to sample marine fish when the tide is high (Figure 6-1).

The cast net was cast three times and immediately taken in and checked for captures. This was then repeated a second time after a 10-min interval because the fish would become habituated to the disturbance and move away from the sampling point. All fishes caught following each cast were counted and identified, then placed in a bucket of water until both sets of cast netting were completed, to prevent double counting. Captured individuals were released back into the waterbody upon completion of the fish-sampling session.

The seine net was deployed parallel to the shore between two people, with each person holding the bottom rope against the substrate (usually with their foot) as firmly as practical and holding the top rope so that it lies along the water surface. The two surveyors walked at equal speed towards the shore, pulling the seine net along. Once the water level is around 0.5 m depth, one surveyor shifted direction and begun to walk towards the other surveyor, walking diagonal to the shoreline, while the other surveyor continued to move straight towards the shore. This process eventually closed the seine net, allowing both surveyors to haul out fauna trapped within.

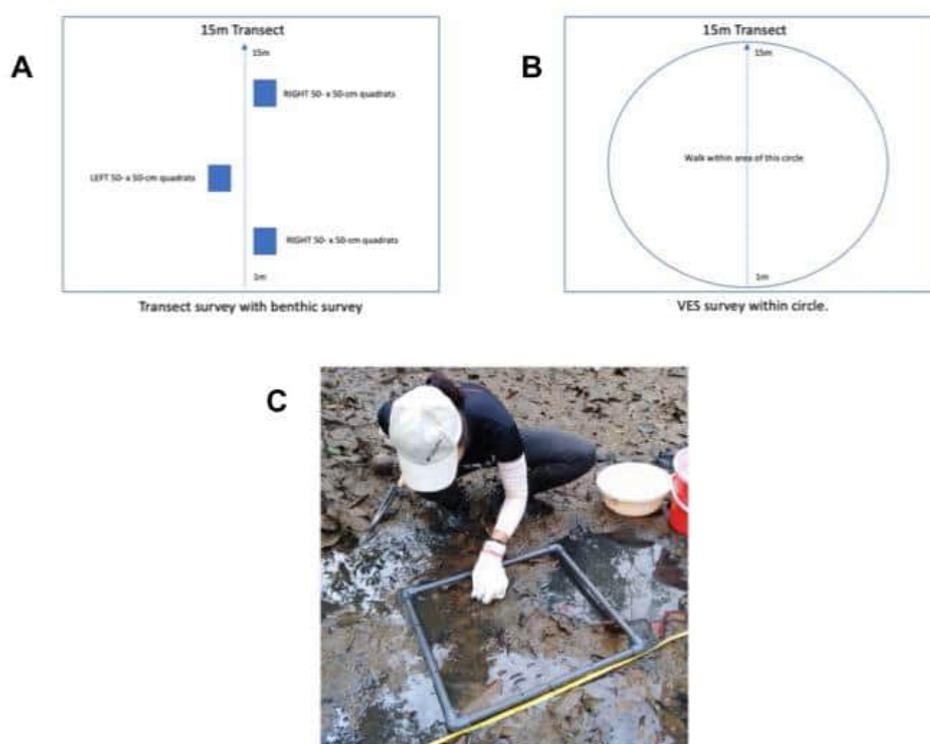

Figure 6-4 (A) Quadrat sampling along 15-m transect, (B) visual survey of the vicinity within the 15-m diameter circle, (C) example of quadrat sampling in the mudflat.

6.2.3 Data Analyses

6.2.3.1 Species Distribution Maps

Locations of species of conservation significance were presented on maps to show their distribution within the Study Area. All maps were prepared and generated using the mapping software QGIS 3.22.4 [O-3].

6.2.3.2 Camera Trapping

Camera trap location, species identity, and the number of individuals were recorded for each video with a positive capture of fauna. An independent detection constitutes a video of one or a group of individuals of the same faunal species occurring within 60 minutes at each camera trap. The number of independent detections was used to calculate the detection rate for each mammalian species.

6.2.3.3 Bat Sound File Analysis

All bat sound files were processed using Kaleidoscope v5.4.6 (Wildlife Acoustics, Inc.) [O-4] to separate extraneous noise from files with bat echolocation calls. The signal parameters for recognising a potential bat echolocation call

were configured as follows: frequency range of 20–200 kilohertz (kHz), duration of 2–500 milliseconds (ms), a maximum inter-syllable gap of 500 ms and a minimum of 2 pulses. These files were visually processed to identify bat species based on call structures, with reference to relevant publications reporting echolocation signatures for bat species in Singapore [P-36, P-37, P-38].

6.2.3.4 Taxon Sampling Curves

Taxon sampling curves were only plotted for taxa with sufficient occurrences during targeted surveys, as large sample sizes are required for a robust estimation of sample coverage [P-39]. Incidence data was used to estimate sample coverage and species richness. Species richness was plotted against sample coverage, as opposed to survey effort. Sample coverage refers to “the proportion of the total number of species in a community that belongs to the species represented in the sample”, i.e., how extensively the species in the community was sampled [P-39].

The taxon sampling curve was extrapolated to provide an estimation of species richness and sample coverage if the sample size was doubled. The associated standard error and 95% confidence interval were also computed. Standard error refers to the range of uncertainty of the estimate, while the 95% confidence interval is the interval in which there is a 0.95 probability of containing the estimated true species richness. As some species will always remain undetected, total species richness had to be estimated via extrapolation. This was done using the Chao estimator. All statistical analyses were carried out in the statistical programming environment R version 3.4.3 [O-5] using the “iNEXT” package 2.0.20 [W-20].

6.3 Baseline Findings

6.3.1 Habitat Types

The flora field assessment found three terrestrial vegetation and two aquatic habitat types within the Study Area. Abandoned-land forest was the most extensive terrestrial vegetation type (24.33%) (Table 6-3; Figure 6-5). While the extent of mangrove forest was comparable at 22.52%, where it was the most dominant habitat along the coastal and intertidal areas of the Study Area (Table 6-3; Figure 6-5). Making the distinction between mangrove and back mangrove forests on site, according to the classification base on Yee et al (2016) [P-32], was not possible as some areas of the mangroves surveyed were too small to provide a conclusive judgement. Therefore, due to the lack of observed zonation, all mangrove habitats identified on site, were broadly classified as as mangrove forests. The remaining delineated terrestrial vegetation comprised of scrubland and herbaceous vegetation (7.35%) (Table 6-3; Figure 6-5) and was mainly observed on the higher portion of the bunds along the disused ponds, as well as along a linear mud track further inland.

The soft-sediment seabed was mainly confined within the disused ponds, comprising 23.13% of the Study Area. While areas outside the disused ponds were considered marine areas (20.60%). This area is also intertidal and exposed during low tides.

Lastly, there were infrastructures such as the kampung houses that still exist within the Study Area and adjacent to Jalan Durian Road which runs along the northern boundary of the Study Area. These comprise 2.07% of the Study Area (Table 6-3; Figure 6-5).

Table 6-3 Area occupied by the various vegetation types.

Vegetation Type	Area (ha)	Percentage of total Study Area (%)
Abandoned-land forest	3.88	24.33
Mangrove forest	3.60	22.52
Scrubland and herbaceous vegetation	1.17	7.35
Soft sediment seabed	3.70	23.13
Marine area	3.29	20.60
Infrastructure	0.33	2.07
Total	15.96	100.00



Legend

- Filled Area
- Overall EIS Study Area
- Mangrove
- Seagrass
- Abandoned-land forest
- Scrubland
- Soft sediment seabed
- Marine area
- Infrastructure

Rev.	Date	By	Description	Chk'd	App'd
-	DEC 2022	SS	EIA Report	NHT	JAG

Qualified Person Endorsement :
NA

NParks Endorsement : NA

Consultant : **AECOM**

Project Title :
**CONTRACT NPARKS/N/39/2017
CONSULTANCY SERVICES FOR SHORELINE
WORKS IN PULAU UBIN
(MANGROVE RESTORATION OF
SUNGEI DURIAN PONDS)**

Designed SS	Checked NHT	Approved JAG
Drawn SS	Date DEC 2022	

Client:

Figure Title:
**Habitats and vegetation distribution within
Study Area**

Figure No. : 6-5	Rev. : -	Sheet : 1 of 1
CAD File Name : NA		A3

6.3.1.1 Abandoned-land Forest

The abandoned-land forest patches observed within Study Area were dominated by non-native crop species such as coconut (*Cocos nucifera*) and betel nut palm (*Areca catechu*) suggesting abandoned-land forest to be abandoned-kampung subtype (i.e. that forest has regrown from land that was previously used for kampungs) [P-32]. *Durio zibethinus*, *Nephelium lappaceum* and *Spathodea campanulata*, were also commonly recorded fruit trees. These species flower and fruit regularly, so their seedlings and saplings are often found in the understorey layer of abandoned-land forests and are good sources of food for fauna. Interestingly, the rambutan (*Nephelium lappaceum*) was previously considered to be nationally Critically Endangered in Singapore [P-8], but has been revised to be Cryptogenic [P-65]—it is speculated that the populations observed within the Study Area were likely relics of past cultivated stock and not dispersed naturally from the native-dominated forests of Singapore. Subsequently, the trees that form the main canopy layer of these abandoned-land forests are also usually remnants from past cultivation, and are mainly of exotic species.

Common native secondary forest trees including wild cinnamon (*Cinnamomum iners*), tembusu (*Cyrtophyllum fragrans*) and native shrub/herb species such as *Centotheca lappacea* and simpoh air (*Dillenia suffruticosa*) were also commonly recorded (Figure 6-6). Recruitment of coastal species of conservation significance like nationally Endangered seashore ardisia (*Ardisia elliptica*) and *Antidesma velutinsum*, and nationally Vulnerable seashore nutmeg (*Knema corticosa*) were observed and recorded throughout the site.



Figure 6-6 Site photos representative of the abandoned-land forest within the Study Area.

6.3.1.2 Mangrove Forest

The mangrove forest recorded in the present study consists of three main patches of mangrove, with the rest of the mangroves scattered along the perimeter of the disused ponds (Figure 6-5 and Figure 6-7). Common mangrove species were observed to be growing on the sides of the bunds, as well as on the top of the bund separating Pond 1 and Pond 2 (Figure 6-8). These include bakau putih (*Bruguiera cylindrica*), large-leaved mangrove (*Bruguiera gymnorhiza*), bakau minyak (*Rhizophora apiculata*), bakau kurap (*Rhizophora mucronata*), and cannonball mangrove (*Xylocarpus granatum*). Other species include small trees and saplings of conservation significant species of nationally Endangered *Ceriops zippeliana* and terentum bunga putih (*Lumnitzera racemosa*) and nipah palm (*Nypa fruticans*).

The establishment of most of the mangrove forest lining the edge of the disused ponds is likely to be after the abandonment of the prawn ponds. Towards the east of Pond 1, mangrove trees observed are of bigger size as compared to mangrove specimens lining the edge of the disused ponds and thus can be inferred to be a relatively mature stand of mangrove forest. This patch is also dominated by common mangrove species such as bakau putih (*Bruguiera cylindrica*), large-leaved mangrove (*Bruguiera gymnorhiza*), bakau minyak (*Rhizophora apiculata*), bakau kurap (*Rhizophora mucronata*), and cannonball mangrove (*Xylocarpus granatum*) (Figure 6-8). Scattered individuals of species of conservation significance include *Ceriops zippeliana* and terentum bunga putih (*Lumnitzera racemosa*).

Subsequently, the other two patches of mangrove forest—(1) north of Study Area, above Pond 1 and (2) north east of Study Area, behind Pond 3—were dominated by nipah palm (*Nypa fruticans*) (Figure 6-5 and Figure 6-9).



Figure 6-7 Site photos representative of the mangrove around the disused ponds within the Study Area.



Figure 6-8 Mangrove forest east of Pond 1.



Figure 6-9 Mangrove dominated by nipah palm (*Nypa fruticans*).

6.3.1.3 Scrubland and Herbaceous Vegetation

Scrubland and herbaceous vegetation were mainly observed on the higher portions of the bunds along the disused ponds, as well as along cleared areas that have formed into a walking trail into Sungei Durian from Jalan Durian (Figure 6-5). Native herbs such as centipede grass (*Ischaemum muticum*) non-native herbs such as smut grass (*Sporobolus indicus*), Javanese flatsedge (*Cyperus javanicus*) dominate, with scattered exotic trees such as albizia (*Falcataria moluccana*) and lead tree (*Leucaena leucocephala*) (Figure 6-10).



Figure 6-10 Site photos representative of the scrubland and herbaceous vegetation within the Study Area.

6.3.1.4 Soft Sediment Seabed

According to NParks (2020) [W-21], such habitats are typically open areas without vegetation and found between mean high-water and mean low-water spring tide datums; it is usually located in estuaries and other low-energy marine environments [P-40]. This habitat was observed within the disused ponds and occupies about 23.13% of the Study Area (Figure 6-5 and Figure 6-10).

Such soft-sediment seabed is the foundation of mangrove forest and if left alone, has the potential to transition to mangrove forest due to evidence of recruitment on site, albeit slow. Additionally, soft-sediment habitats are also associated with high organic waste where most of the biomass is just found below the surface, where these macrobenthos communities serve as an important food source for shore birds.

A small, scattered seagrass patch of 0.078 ha was observed within Pond 2 (Figure 6-5). Only one seagrass species was recorded within this patch, the spoon seagrass (*Halophila ovalis*) (Figure 6-10B).

Seagrass tends to be found within the intertidal and shallow subtidal zones due to the need for sunlight for photosynthesis. Seagrass meadows are an important component of the marine environment, providing vital ecosystem services such as nutrient cycling, food provision, and climate change mitigation [P-41, P-42]. Similarly, if left alone, there is potential for the seagrass patch to increase in size—albeit slow—due to the potential presence of connectivity with the nearby seagrass meadow at Chek Jawa.



Figure 6-11 (A) Site photos representative of the soft sediment seabed within the Study Area and (B) spoon seagrass (*Halophila ovalis*).

6.3.1.5 Marine Area

The Marine Area makes up 20.60% of the Study Area. This area is characterised by a mix of sediment types, including loose deposits of sand, gravel, shells and even some soft-sediment seabed areas (Figure 6-12).

This habitat can also be partially considered intertidal as at very low tides, the seabed does get exposed. This habitat can support a diversity of marine fauna such as snapping shrimps and their symbiotic shrimp gobies. Sting rays, sole fish and sand dollars would also utilise the sandy seabed.

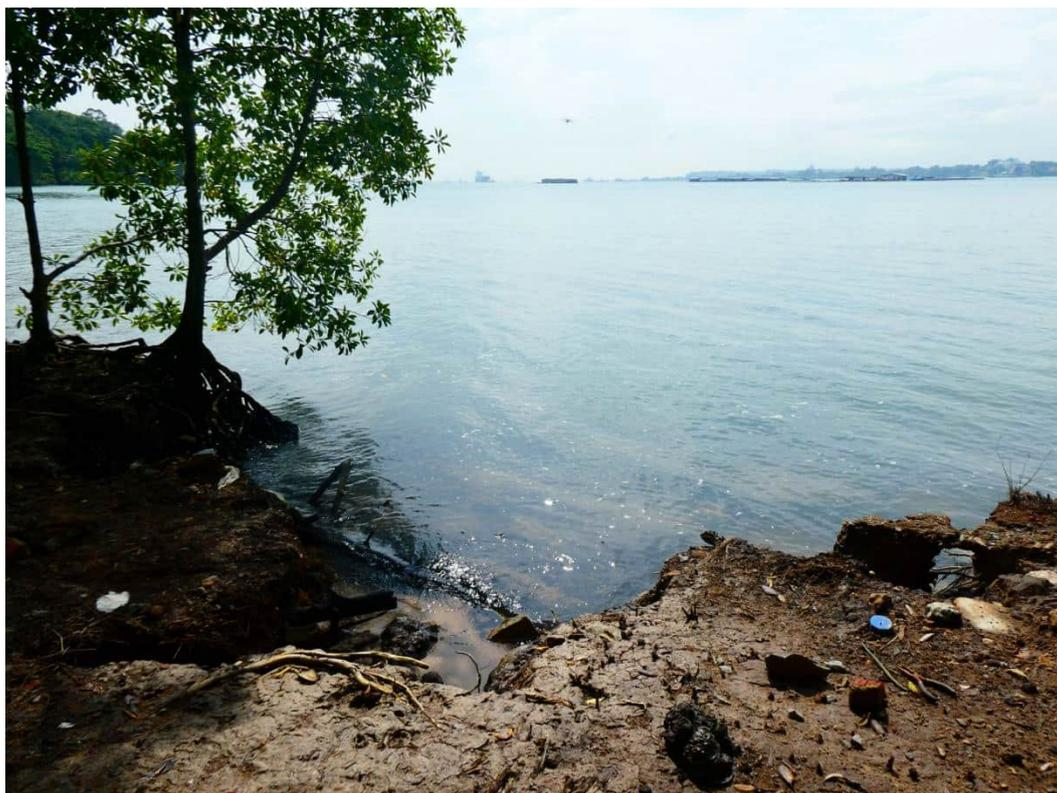

Figure 6-12 Site photos representative of the Marine Area within the Study Area.

6.3.1.6 Infrastructure

Infrastructure makes up the smallest proportion of the Study Area at 0.33 ha (2.07%) (Table 6-3). These areas are kampung houses with some managed planting around them —located northeast of the Study Area—both along the cleared areas that almost form like a trail into Sungei Durian from Jalan Durian. These houses currently have residents staying in them and should not be considered abandoned (Figure 6-13). Jalan Durian Road, which cuts across the Study Area in the north, also forms part of the infrastructure considered within this Study Area (Figure 6-5).



Figure 6-13 Site photos representative of infrastructure within the Study Area.

6.3.2 Flora Inventory

In this survey, a total of 195 species of vascular plants from 72 families were recorded (Appendix A). This consisted of 90 trees, 29 climbers, 35 herbs, 35 shrubs, 4 epiphytes, one strangler and one seagrass. Native species dominated the assemblage with 137 species (70.98%), with three species considered to be persistent through cultivation and not dispersed naturally from the native-dominated forests of Singapore—nationally Critically Endangered *Baccaurea motleyana* and *Gnetum gnemon* var. *gnemon*, and common native *Syzygium polyanthum*. 53 were exotic plant species (26.42%), and 5 (2.59%) were cryptogenic (Table 6-4). Of all the plant species recorded, 18 (9.32%) were true mangrove species according to NParks [W-21].

The inventory of all species recorded within the Study Area is shown in Appendix A. The inventory of true mangrove species recorded is shown in Appendix B.

Table 6-4 Total number of plant species recorded in the Study Area summarised by their native and national status.

Origin	National Status	No. of Species	Percentage of all Species (%)
Exotic		53	26.42
Cryptogenic		5	2.59
Native	Common	85	43.52
	Vulnerable	25	12.95
	Endangered	13	6.74
	Critically Endangered	14*	7.25
	Total		137
Total		195	100.0

* presents of specimen persistent from cultivation.

6.3.2.1 Plants of Conservation Significance

The survey catalogued 52 plant species of conservation significance, representing 28.35% of the total number of plant species recorded. Of these, 50 were non-cultivated conservation significant species--25 were nationally Vulnerable, 13 were nationally Endangered and 12 were nationally Critically Endangered. The other two conservation significant species were specimens considered to be persistent likely through cultivation—both nationally Critically Endangered. The distribution of mangrove species of conservation significance were scattered sparingly throughout the mangrove area. Two areas in the mangrove were observed to be dominated by *Nypa fruticans*, (1) northeast, behind Pond 3 and (2) north of Study Area, above Pond 1 (Figure 6-9). The distribution of the other non-mangrove conservation significant plants were scattered mainly throughout the abandoned-land forest further inland, while a lower concentration of conservation significant species were found in the scrubland and herbaceous vegetation (Figure 6-14; Figure 6-15). A small, scattered seagrass patch was observed within Pond 2 (Figure 6-11).

The locations of the plants of conservation significance are listed in Appendix C.

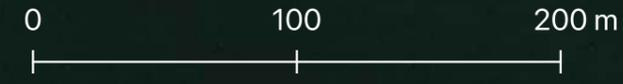

Figure 6-14 Nationally Vulnerable A) *Symplocos fasciculata* and B) *Utania nervosa*.



Conservation Significant Flora Species

- Critically endangered
- Endangered
- Vulnerable



Legend

- Filled Area
- Scrubland
- Overall EIS Study Area
- Soft sediment seabed
- Mangrove
- Marine area
- Seagrass
- Infrastructure
- Abandoned-land forest

Rev.	Date	By	Description	Chk'd	App'd
-	DEC 2022	SS	EIA Report	NHT	JAG

Qualified Person Endorsement :
NA

NParks Endorsement : NA

Consultant : **AECOM**

Project Title :
**CONTRACT NPARKS/N/39/2017
CONSULTANCY SERVICES FOR SHORELINE
WORKS IN PULAU UBIN
(MANGROVE RESTORATION OF
SUNGEI DURIAN PONDS)**

Designed SS	Checked NHT	Approved JAG
Drawn SS	Date DEC 2022	

Client:

Figure Title:
**Distribution of flora species of conservation
significance within Study Area**

Figure No. : 6-15	Rev. -	Sheet 1 of 1
CAD File Name : NA		A3

6.3.2.2 Significant Large Trees

A total of four significant large trees with girth >3m comprising of four species were documented within the Study Area. The significant large trees were all common species, with one specimen each of tembusu (*Cyrtophyllum fragrans*), coastal she-oak (*Casuarina equisetifolia*), white fig (*Ficus caulocarpa*) and Malayan banyan (*Ficus microcarpa*). All the significant large trees were found in the abandoned-land forest (Figure 6-16).

The list of locations of the individual significant large trees is provided in Appendix D.



● Large flora specimens (tree with girth >3m)

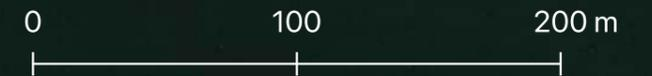

Legend

- Filled Area
- Overall EIS Study Area
- Mangrove
- Scrubland
- Seagrass
- Marine area
- Infrastructure
- Abandoned-land forest
- Soft sediment seabed



Rev.	Date	By	Description	Chk'd	App'd
-	DEC 2022	SS	EIA Report	NHT	JAG

Qualified Person Endorsement : NA

NParks Endorsement : NA

Consultant : **AECOM**

Project Title :
**CONTRACT NPARKS/N/39/2017
 CONSULTANCY SERVICES FOR SHORELINE
 WORKS IN PULAU UBIN
 (MANGROVE RESTORATION OF
 SUNGEI DURIAN PONDS)**

Designed SS	Checked NHT	Approved JAG
Drawn SS	Date DEC 2022	

Client:

Figure Title:
**Distribution of large flora specimens within
 Study Area**

Figure No. : 6-16	Rev. : -	Sheet : 1 of 1
----------------------	-------------	-------------------

CAD File Name : NA

6.3.3 Faunistic Field Findings

6.3.3.1 Overall

A total of 285 species were recorded, 128 terrestrial species and 157 aquatic species. 128 terrestrial faunal species recorded consists of 16 odonates, 29 butterflies, four amphibians, seven reptiles, 58 birds and 14 mammals—of which 17 species are of conservation significance and were widely distributed in the Study Area (Figure 6-17; Table 6-5). 157 aquatic faunal species recorded consist of 23 fish, 26 decapod crustaceans, 107 molluscs and one xiphosurid—of which three are of conservation significance, with distribution confined to the aquatic sampling points (Figure 6-17; Table 6-5).

The inventory of all fauna species recorded within the Study Area is shown in Appendix F.

Table 6-5 All Conservation Significant fauna species found at Sungei Durian

Type	Family	Scientific Name	Common Name	Global Status (IUCN/CITES)	National Status	Distribution/Rarity
Bird	Accipitridae	<i>Nisaetus cirrhatus</i>	Changeable hawk-eagle	Least Concern; CITES protected (Appendix II)	Endangered	Uncommon
Bird	Alcedinidae	<i>Alcedo atthis</i>	Common kingfisher	Least Concern	Vulnerable	Common
Bird	Ardeidae	<i>Ardea cinerea</i>	Grey heron	Least Concern	Vulnerable	Uncommon
Bird	Ardeidae	<i>Ardea sumatrana</i>	Great-billed heron	Least Concern	Critically Endangered	Uncommon
Bird	Muscicapidae	<i>Copsychus malabaricus</i>	White-rumped shama	Least Concern	Critically Endangered	Uncommon
Bird	Muscicapidae	<i>Copsychus saularis</i>	Oriental magpie-robin	Least Concern	Endangered	Uncommon
Bird	Nectariniidae	<i>Leptocoma calcostetha</i>	Copper-throated sunbird	Least Concern	Vulnerable	Uncommon
Bird	Pycnonotidae	<i>Pycnonotus zeylanicus</i>	Straw-headed bulbul	Critically Endangered; CITES protected (Appendix II)	Endangered	Uncommon
Bird	Scolopacidae	<i>Actitis hypoleucos</i>	Common sandpiper	Least Concern	Vulnerable	Common
Butterfly	Nymphalidae (Brush Foots)	<i>Euploea tulliolus ledereri</i>	Dwarf crow	Not Listed	Endangered	Moderately rare
Butterfly	Nymphalidae (Brush Foots)	<i>Polyura moori moori</i>	Malayan nawab	Not Listed	Nationally Extinct (Rediscovered)	Very rare (seasonal migrant)
Damselfly	Coenagrionidae	<i>Mortonagrion arthuri</i>	Arthur's midget	Near Threatened	Vulnerable	Restricted and Rare
Decapod	Thalassinidae	NA	Mud mound lobster	Not Assessed	Endangered	NA
Mammal	Cercopithecidae	<i>Macaca fascicularis</i>	Long-tailed macaque	Vulnerable; CITES protected (Appendix II)	Least Concern	Widespread and Common
Mammal	Felidae	<i>Prionailurus bengalensis</i>	Leopard cat	Least Concern; CITES protected (Appendix I)	Critically Endangered	Restricted and Rare
Mammal	Mustelidae	<i>Lutrogale perspicillata</i>	Smooth otter	Vulnerable; CITES protected (Appendix I)	Endangered	Widespread but Rare
Mammal	Tragulidae	<i>Tragulus napu</i>	Greater mousedeer	Least Concern	Critically Endangered	Restricted and Rare
Mollusc	Neritidae	<i>Clithon oualaniense</i>	NA	Least Concern	Vulnerable	NA

Type	Family	Scientific Name	Common Name	Global Status (IUCN/CITES)	National Status	Distribution/Rarity
Reptile	Typhlopidae	<i>Argyrophis muelleri</i>	White-bellied blind snake	Least Concern	Critically Endangered	Widespread but Rare
Xiphosurid	Limulidae	<i>Carcinoscorpius rotundicauda</i>	NA	Data Deficient	Vulnerable	NA
<p>* There are a total of four species of mud lobster/shrimp—three have national conservation significance of Endangered and one is Not Assessed. For the ease of analysis and reporting, these species will be considered collectively as one species with national conservation significance status of Endangered.</p>						

Conservation Significant Fauna Species

Terrestrial and Marine

- Ardea sumatrana
- Copsychus malabaricus
- Copsychus saularis
- Nisaetus cirrhatus
- Pycnonotus zeylanicus
- Leptocoma calcostetha
- Actitis hypoleucos
- Alcedo atthis
- Ardea cinerea
- Tragulus napu
- Lutrogale perspicillata
- Macaca fascicularis
- ▲ Argyrophis muelleri
- ★ Euploea tulliolus ledereri
- ★ Polyura moori moori
- ▶ Mortonagrion arthuri
- Carcinoscorpis rotundicauda
- ◐ Clithon oualaniense

Global/National Status

- Nationally Extinct (Rediscovered)
- Critically Endangered
- Endangered
- Vulnerable

Sampling methods

Sampling routes

- Transect 1
- Transect 2
- Camera



Legend

- Filled Area
- Overall EIS Study Area
- Mangrove
- Seagrass
- Scrubland
- Soft sediment seabed
- Marine area
- Infrastructure
- Abandoned-land forest



Rev.	Date	By	Description	Chk'd	App'd
-	DEC 2022	SS	EIA Report	NHT	JAG

Qualified Person Endorsement :
NA

NParks Endorsement : NA

Consultant : **AECOM**

Project Title :
**CONTRACT NPARKS/N/39/2017
CONSULTANCY SERVICES FOR SHORELINE
WORKS IN PULAU UBIN
(MANGROVE RESTORATION OF
SUNGEI DURIAN PONDS)**

Designed SS	Checked NHT	Approved JAG
Drawn SS	Date DEC 2022	

Client:

Figure Title:
Locations of faunal species of conservation significance, excluding camera trap records

Figure No. : 6-17	Rev. : -	Sheet : 1 of 1
CAD File Name : NA		A3

6.3.3.1.1 Odonates

A total of 16 species were recorded, of which one is of conservation significance, the nationally Vulnerable, restricted and rare Arthur's midget (*Mortonagrion arthuri*) (Figure 6-18A). This damselfly inhabits back mangrove. Other than Ubin, it is currently known from a few sites in Singapore such as the mangrove area in Admiralty Park, Pulau Semakau and Tekong [P-72]. The species is also globally Near Threatened. In the Study Area, it was found along Transect 2, at the northern section of Pond 1 (Figure 6-17).

Apart from Arthur's midget, two other back mangrove odonates that are nationally Near Threatened due to vulnerability of habitat loss are mangrove marshal (*Pornothemis starrei*) (Figure 6-18B) and mangrove dwarf (*Raphismia bispina*) (Figure 6-18C). The presence of these three species is an indication of a healthy mangrove habitat. The nationally rare and Near Threatened lined forest skimmer dragonfly (*Cratilla lineata*) was also recorded. Pulau Ubin is a stronghold for this species.

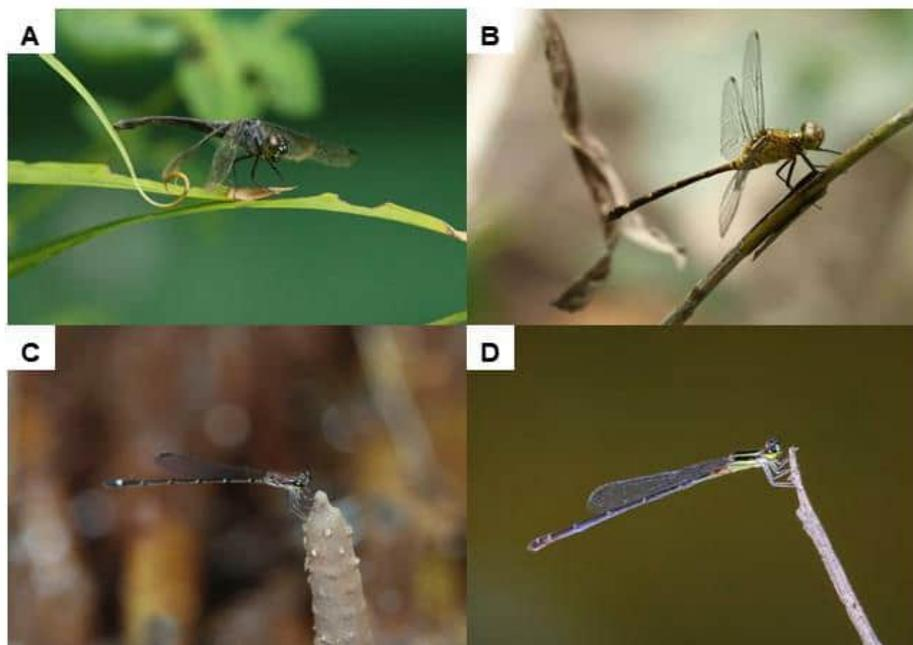

Figure 6-18 Odonates found within Sungei Durian. A) Mangrove dwarf (*Raphismia bispina*), B) mangrove marshal (*Pornothemis starrei*), C) Arthur's midget (*Mortonagrion arthuri*) and D) variable sprite (*Argiocnemis rubescens rubeola*).

6.3.3.1.2 Butterflies

29 species of butterflies were recorded in the Study Area, of which four were identified only to genus level. They are *Miletus* species (Lycaenidae), and three from the Nymphalidae family: *Euploea* species, *Neptis* species and *Polyura* species. There are two species of conservation significance [P-8], the nationally Extinct (rediscovered) Malayan nawab (*Polyura moori moori*) (Figure 6-19A) and the nationally Endangered dwarf crow (*Euploea tulliolus ledereri*). They were recorded along Transect 1, between Pond 2 and 3 in mangrove habitats (Figure 6-17).

The Malayan nawab was rediscovered in Pulau Ubin since 2012 [P-11] and is considered a very rare seasonal migrant [P-12]. It is known to feed on the ripened fruits of *Melastoma malabathricum* which exists within the Study Area. Also rediscovered in Ubin is the moderately rare dwarf crow in 2002 [P-11, P-12]. While rare in mainland Singapore, there is a healthy population in Ubin likely due to the presence of its host plant the burny vine (*Trophis scandens*) [P-49].

The moderately rare common jay (*Graphium doson evemonides*), only recorded in Ubin, was discovered in 2004 [P-12] but have since seem to establish sustainable colony on Pulau Ubin [W-27]. Among its various host plants, the dwarf ylang ylang (*Desmos chinensis*) is abundant in Ubin and appears to be the host of choice on the island. Other known host plants are white champaca (*Michelia alba*) and false ashoka tree (*Polyathia longifolia* var. *pendula*) [W-22].

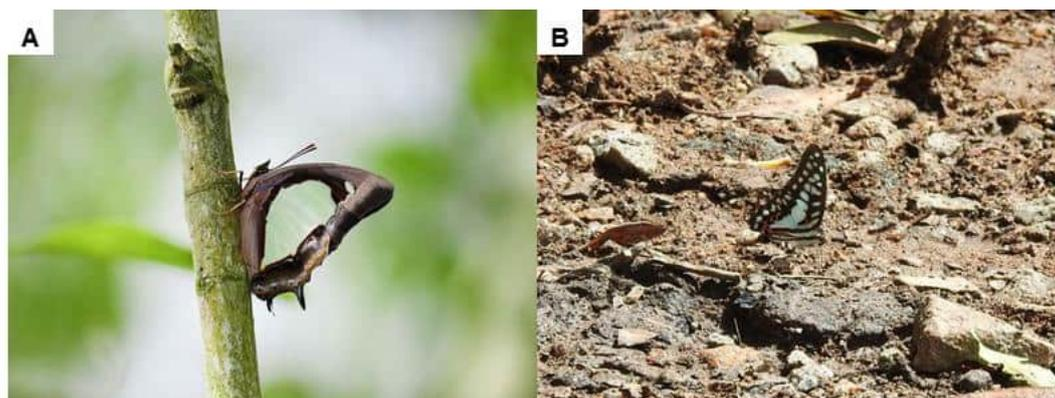

Figure 6-19 Conservation significant butterflies found within Sungei Durian. A) Malayan nawab (*Polyura moori moori*) and B) common jay (*Graphium doson evemonides*).

6.3.3.1.3 Amphibians

Only four amphibian species were recorded: crab-eating frog (*Fejervarya cancrivora*) (Figure 6-20B); dark-sided chorus frog (*Microhyla heymonsi*); four-lined tree frog (*Polypedates leucomystax*) (Figure 6-20A) and Asian toad (*Duttaphrynus melanostictus*). This low diversity is unsurprising given the lack of freshwater habitats in the Study Area. All four species are native, widespread and common [P-2].



Figure 6-20 Frogs found within Sungei Durian A) *Polypedates leucomystax*, B) *Fejervarya cancrivora*.

6.3.3.1.4 Reptiles

Seven species of reptiles were recorded. The majority of the species recorded are widespread and common, or uncommon species. However, one species, the white-bellied blind snake (*Argyrophis muelleri*) (Figure 6-21B) is nationally Critically Endangered, widespread but rare [P-2]. This fossorial snake is highly elusive. Aside from Ubin, it also exists in Central Catchment and Bukit Timah Nature Reserves [W-23]. Additionally, Baker and Choo (2014) [P-50] found an individual in a roadside drain by a secondary forest and plant nursery at Ulu Sembawang. The record from this project was along Transect 1 in the abandoned-land forest north of Pond 3 (Figure 6-17).



Figure 6-21 Snakes found within Sungei Durian A) Striped bronzeback (*Dendrelaphis caudolineatus*), B) White-bellied blind snake (*Argyrophis muelleri*), C) Oriental whip snake (*Ahaetulla prasina*).

6.3.3.1.5 Birds

A total of 58 bird species were recorded from the Study Area. The diversity was composed of 42 largely common or uncommon resident breeders, two each of migrant breeders and introduced resident breeder, one non-breeding visitor, 10 winter visitors and one passage migrant [W-11].

Of the 58 species, nine of them are of conservation significance (Figure 6-17) [P-8]. Two are nationally Critically Endangered, great-billed heron (*Ardea sumatrana*) (Figure 6-22A) and white-rumped shama (*Copsychus malabaricus*). Three are nationally Endangered, changeable hawk-eagle (*Nisaetus cirrhatus*) CITES protected (Appendix II), oriental magpie-robin (*Copsychus saularis*) and straw-headed bulbul (*Pycnonotus zeylanicus*) which is also globally Critically Endangered, CITES protected (Appendix II). Two species is nationally Vulnerable, the grey heron (*Ardea cinerea*) (Figure 6-22B) and spotted wood owl (*Strix seloputo*). These seven species are considered uncommon resident breeders [W-11]. The survey findings do not indicate a distinctive pattern in their distribution within the Study Area except for the great-billed and grey herons which are naturally found closer to the Marine Area.



Figure 6-22 Birds found within Sungei Durian A) Great billed heron (*Ardea sumatrana*), B) Grey heron (*Ardea cinerea*), C) Black capped kingfisher (*Halcyon pileata*) and D) Sunda pygmy woodpecker (*Yungipicus moluccensis*).

6.3.3.1.6 Mammals

14 species of mammals were recorded consisting of eight non-volant and six bat species. Four of the recorded mammals are of conservation significance [W-5]. They are the nationally Critically Endangered leopard cat (*Prionailurus bengalensis*) and greater mousedeer (*Tragulus napu*), nationally Endangered smooth-coated otter (*Lutrogale perspicillata*) (Figure 6-6-23A) which is also globally Vulnerable, and the globally Vulnerable long-tailed macaque (*Macaca fascicularis*). All six species of recorded bats are widespread and common except the widespread but rare black-bearded tomb bat (*Taphozous melanopogon*).

Four observations of two individuals of the restricted and rare leopard cat were made on camera traps CT02 and CT03 (Figure 6-17). The cameras were located at the perimeter of Pond 3 at the transition zone between mangrove and scrubland. Said et al. (2022) [P-51] reported a spate of leopard cat sightings from the island in 2021. Their sightings, together with others from 1997 and 2014, suggest there is likely a resident population [P-51]. Findings from this study lends support to that hypothesis.

Records of the restricted and rare greater mousedeer were mainly along Transect 1 and 2 in the scrubland and abandoned-land forest habitats on the landward side of the three disused ponds. It was also recorded across all four camera traps with CT01 and CT04 having the most captures. The species was first re-discovered on the island in 2008, and subsequent sighting suggests although widely distributed, there appears to be a cluster in both western and eastern forest fragments [P-52]. A first record on mainland Singapore in Western Catchment was reported by Chua (2015) [P-53].

The smooth-coated otter was largely recorded in Transect 1 and 2 on the seaward side of the disused ponds in mangrove habitat. They were also captured in camera traps CT02 and CT03, and observed in the Marine Area during shorebird surveys. Long-tailed macaques were recorded on the landward side of Transect 2 near Jalan Durian during visual surveys. All four cameras also captured the macaques with CT01 having the most observations, thereby indicating the macaques utilised the entire Study Area's terrestrial section.

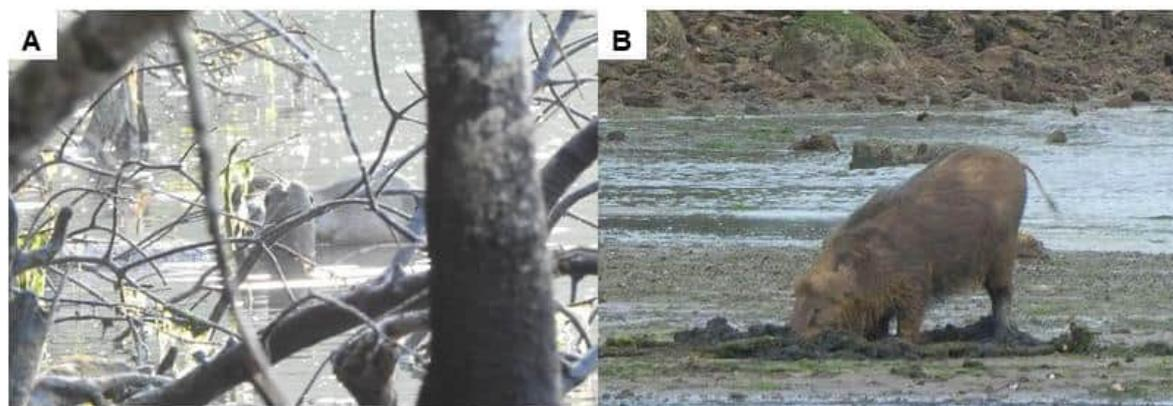

Figure 6-6-23 Mammals found within Sungei Durian. A) Smooth-coated otter (*Lutrogale perspicillata*), B) Wild boar (*Sus scrofa*) foraging in mudflat.

The five camera traps yielded 3014 independent detections and 23 species—13 birds, eight (8) mammals and two (2) reptiles—over 300 trap-nights.

The most commonly recorded non-volant mammalian species was the wild pig (*Sus scrofa*), with 2158 independent detections across all the camera traps. Long-tailed macaque (*Macaca fascicularis*) was the second most frequently recorded with 262 independent detections. CT02-04 all captured 12 species while species richness was lowest at CT01 and CT05 (7-8 species).

A summary of all camera trap captures can be found in Table 6-6. Refer to Appendix G for more detailed information.

Table 6-6 Result summary of camera trap data.

Scientific Name	Common Name	Station	No. of Independent Detections
<i>Acridotheres javanicus</i>	Javan myna	CT03	21
<i>Amaurornis phoenicurus</i>	White-breasted waterhen	CT05	1
<i>Callosciurus notatus</i>	Plantain squirrel	CT04	1
<i>Caprimulgus macrurus</i>	Large-tailed nightjar	CT02	1
<i>Chalcophaps indica</i>	Common emerald dove	CT02, CT04	10
<i>Copsychus malabaricus</i>	White-rumped shama	CT01, CT04	5
<i>Copsychus saularis</i>	Oriental magpie-robin	CT05	2
<i>Felis catus</i>	Feral cat	CT01-04	101
<i>Gallus gallus</i>	Red junglefowl	CT01-04	62
<i>Lutrogale perspicillata</i>	Smooth otter	CT02-03	6
<i>Macaca fascicularis</i>	Long-tailed macaque	CT01-04	262
<i>Paradoxurus musangus</i>	Sumatran palm civet	CT01-05	85
<i>Pcynonotus plumosus</i>	Olive-winged bulbul	CT05	1
<i>Picus vittatus</i>	Laced woodpecker	CT04	2
<i>Pitta moluccensis</i>	Blue-winged pitta	CT04	1
<i>Prionailurus bengalensis</i>	Leopard cat	CT02-03	4
<i>Rhipidura javanica</i>	Malaysian pied fantail	CT01	2

Scientific Name	Common Name	Station	No. of Independent Detections
<i>Spilopelia chinensis</i>	Spotted dove	CT02	1
<i>Strix seloputo</i>	Spotted wood owl	CT03	1
<i>Sus scrofa</i>	Eurasian wild boar	CT01-05	2158
<i>Tragulus napu</i>	Greater mousedeer	CT01-05	228
<i>Varanus nebulosus</i>	Clouded monitor	CT03	3
<i>Varanus salvator</i>	Malayan water monitor	CT02-05	52
			3014

6.3.3.1.7 Fish

A total of 23 species were recorded as part of the baseline study. No conservation significant species was recorded. Due to the conditions of the aquatic habitat in the Study Area, most of the fish species found here were tolerant of large salinity ranges.

Species that were highly tolerant of large salinity ranges include Whitespot (*Aplocheilichthys armatus*), Sunda pygmy halfbeak (*Dermogenys collettei*) and Javanese ricefish (*Oryzias javanicus*). These species can also exist within disturbed freshwater streams with little salinity.

While species such as the gobies (including mudskipper), halfbeaks and archerfish—common mangrove inhabitants—were frequently encountered within the Study Area, especially within the Ponds. The silver-lined and yellow-spotted mudskipper were the most frequent gobies encountered and can be seen during low-tide within the Ponds (Figure 6-24).

At fish sampling points F_01 and F_02 (just outside the Ponds), more marine species were recorded. This includes kops' glass perchlet (*Ambassis kopsii*), slender mojarra (*Gerres oyena*), shortnose gizzard shad (*Anodontostoma chacunda*) and silver sand whiting (*Sillago sihama*). A picklehandle baracacuda (*Sphyræna jello*) was also recorded, albeit of a small size (Figure 6-24).

Refer to Appendix E for the list of recorded species and Appendix F for the location of species recorded.



Figure 6-24 Fish found within Sungei Durian. A) Goby species (*Pseudogobius javanicus*), B) Yellow-spotted mudskipper (*Periophthalmus walailakae*), C) Picklehandle baraccuda (*Sphyræna jello*), and D) Kops' glass perchlet (*Ambassis kopsii*).

6.3.3.1.8 Decapods

A total of 26 species were recorded as part of the baseline study. No freshwater decapod was recorded as there were no suitable habitat within Study Area. All species recorded were typical of mangrove/marine habitats. Out of the 26 species, one “species” of conservation significant species was present—mud mound lobsters (Family Thalassinidae) and/or mud mound shrimps (Family Upogebiidae). It should be noted that, the mud mound lobsters/shrimps species were not sighted as it was difficult to get a sighting of the species due to their elusive lifestyle and complex burrow network. Instead, active mounds (i.e. mud of the mounds were either wet or soft, not dry and in some instance, the mounds had fresh mud around the mouth of the mounds) were used as an indication for presence of these species (Figure 6-25). As such, mounds were seen throughout the Study Area lining the edge of the Ponds and on the bunds between the Ponds, indicating presence of mud mound lobster/shrimps utilising the Study Area. There are a total of four species in the two Family combined—three have national conservation significance of Endangered and one is Not Assessed. For the ease of analysis and reporting, these species will be considered collectively as one species with national conservation significance status of Endangered.

Of the other decapod species recorded, Family Sesamidae had the most number of species records. This is not surprising considering that the Family Sesamidae is one of the most diverse crab family of the marine intertidal and mangrove zones [P-66]; in Singapore, 36 of the 87 mangrove crabs in Singapore belongs to the Family Sesamidae [P-67]. Some of these species include *Episesarma versicolor*, *Selatium brockii*, *Parasesarma rutilimanum* and *Fasciarma fasciatum*. Hermit crabs were also recorded during the survey—commonly found within discarded gastropod shells all over the Ponds (Figure 6-25).

Subsequently, it was also interesting to note that the orange fiddler crab (*Gelasimus vocans*) was recorded in large numbers during low tide within Pond 2 and 3 (Figure 6-25). Both males and females were sighted which may indicate potential breeding ground.

Refer to Appendix E for the list of recorded species and Appendix F for the location of species recorded.

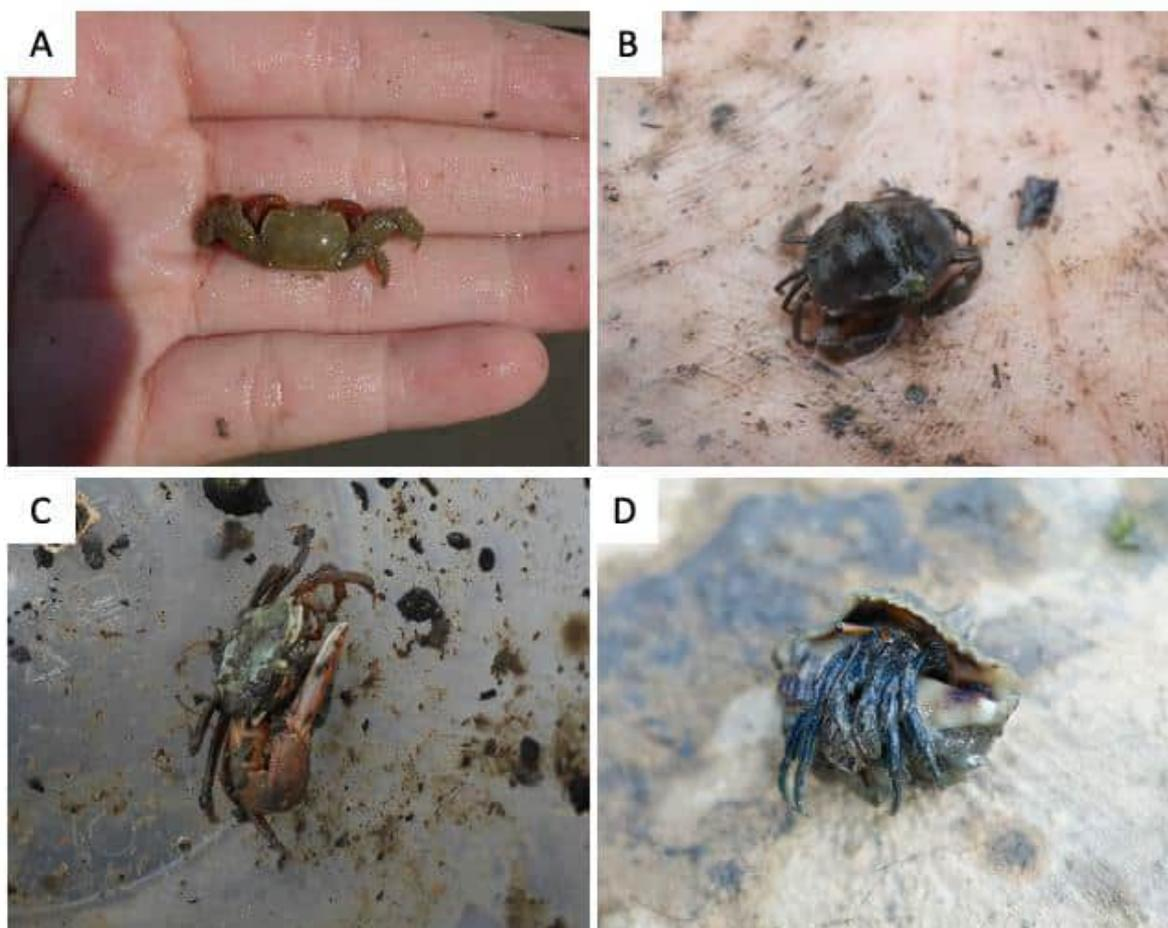

Figure 6-25 Decapods found within Sungei Durian. A) *Clibanarius longitarsus*, B) *Paracleistostoma depressum*, C) *Praosia punctata* and D) *Gelasimus vocans*.

6.3.3.1.9 Molluscs

A total of 107 species were recorded as part of the baseline study, including one species of conservation significance—dubious nerite (*Clithon oualaniense*) (Figure 6-26). This species is considered nationally Vulnerable and was recorded MF03, MF06 and MF07 (Figure 6-17).

One non-marine mollusc was recorded—the golden apple snail (*Pomacea canaliculata*). It is likely that this non-native species was washed down into Study Area from surrounding terrestrial areas.

The rest of the mollusc species recorded were marine and characteristic of mangrove habitats. Commonly encountered bivalve include species from the Veneridae and Arcidae Family (Figure 6-26). While common gastropoda were recorded from Cerithiidae and Potamididae Family (Figure 6-26).

Refer to Appendix E for the list of recorded species and Appendix F for the location of species recorded.

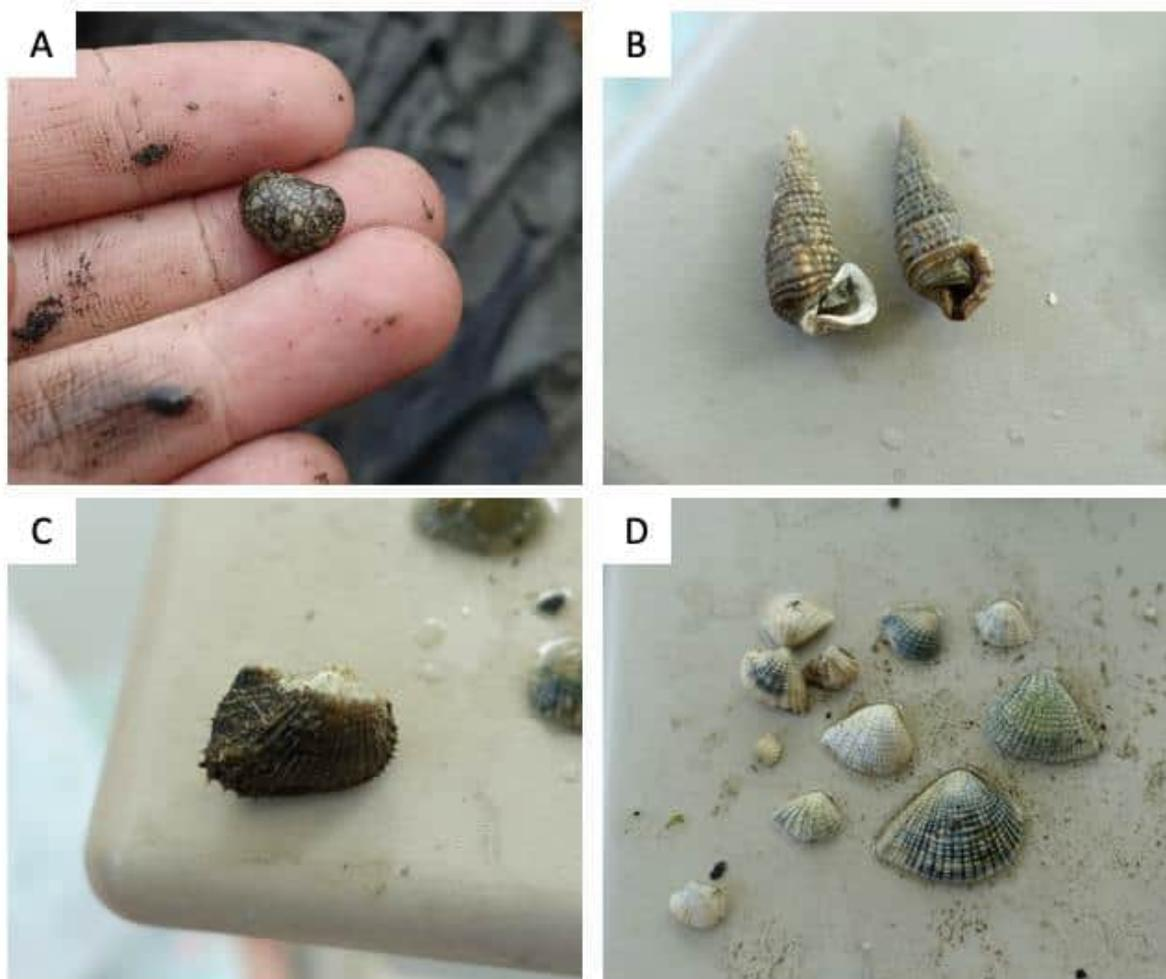

Figure 6-26 Molluscs found within Sungei Durian. A) Dubious nerite (*Clithon oualaniensis*), B) *Pirenella alata* *Pirenella cingulate*, C) *Anadara antiquata* and D) *Anomalocardia squamosa*.

6.3.3.1.10 Xiphosurids

Only one species of xiphosurid was recorded from the surveys: the nationally Vulnerable mangrove horseshoe crab (*Carcinoscorpius rotundicauda*) (Figure 6-27). The species was at MF09 and MF07 (Figure 6-17). Only one individual was recorded at each of the points. Therefore, it is unlikely that species is using this as a breeding ground and is likely to be just passing through.

Refer to Appendix E for the list of recorded species and Appendix F for the location of species recorded.



Figure 6-27 Mangrove horseshoe crab (*Carcinoscorpius rotundicauda*) recorded within Sungei Durian.

6.3.3.2 Taxon Sampling Curves

For transect surveys, sample coverage was generated for the following target taxa: 1) butterflies, 2) odonates (damselflies and dragonflies), 3) amphibians, 4) reptiles, 5) birds, and 6) mammals (including bats). For camera trapping, sample coverage was generated for mammals only. For quadrat sampling, sample coverage was generated for the following taxa: 1) fishes, 2) decapod crustaceans, and 3) molluscs. Sample coverage was not generated for the following methodologies due to their small sample size: roost emergence surveys, shorebird point counts, tray and scoop netting, as well as minnow trapping. Taxon with less than two recorded species, i.e., xiphosurids, were also excluded from the analysis. Sample coverages were mostly above 70%, except transect surveys for reptiles (Table 6-7). The low sample coverage for reptiles is likely due to the low number of observed richness onsite compared to the estimated richness.

Table 6-7 Result summary of taxon sampling analysis table.

Faunal group	Sample coverage (%)	Observed Richness	Estimated Richness (\pm S.E.)	95% Confidence Interval
Transect Surveys				
Butterflies	77.9	26	38.32 \pm 9.19	29.35–71.34
Odonates	85.7	16	19.15 \pm 3.43	16.56–33.81
Amphibians	100	4	4 \pm 0.51	4–5.64
Reptiles	48.4	7	20.13 \pm 11.82	9.90–66.45
Birds	89.6	55	68.16 \pm 8.00	59.38–94.52
Mammals (including bats)	98.9	11	11.11 \pm 0.4	11.00–13.69
Camera Trapping				
Mammals	88.4	23	30.97 \pm 7.46	24.68–60.70
Quadrat Sampling				
Fishes	69.6	9	11.7 \pm 3.2	9.4–25.9

Faunal group	Sample coverage (%)	Observed Richness	Estimated Richness (± S.E.)	95% Confidence Interval
Decapod crustaceans	55.0	5	10.1 ± 6.0	5.8–36.9
Molluscs	81.5	46	80.6 ± 21.2	57.4–150.8

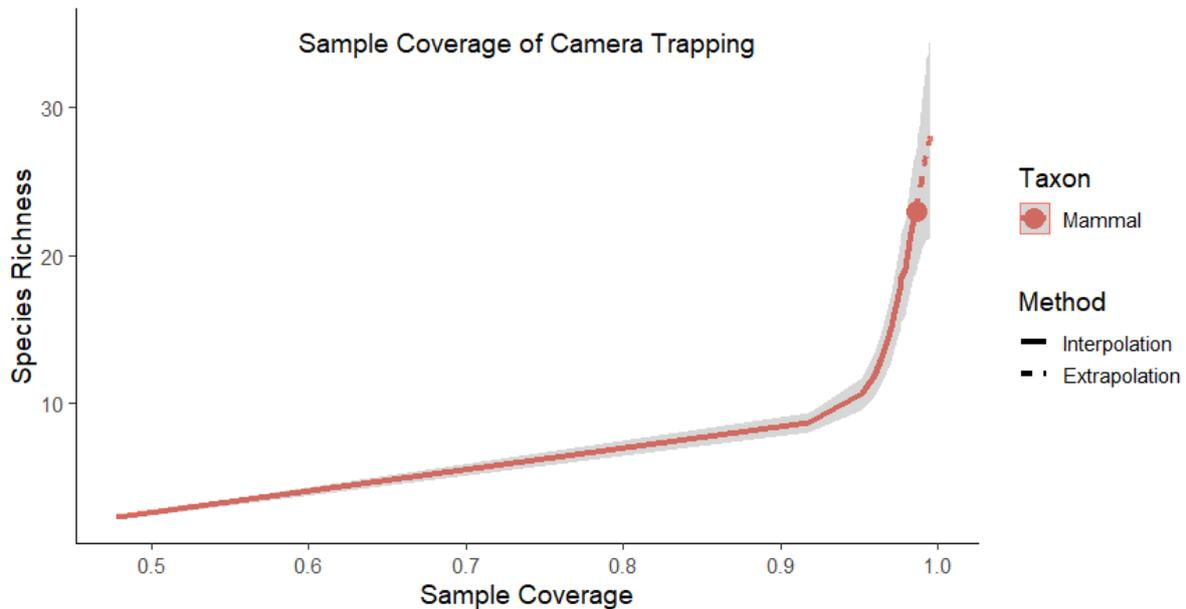
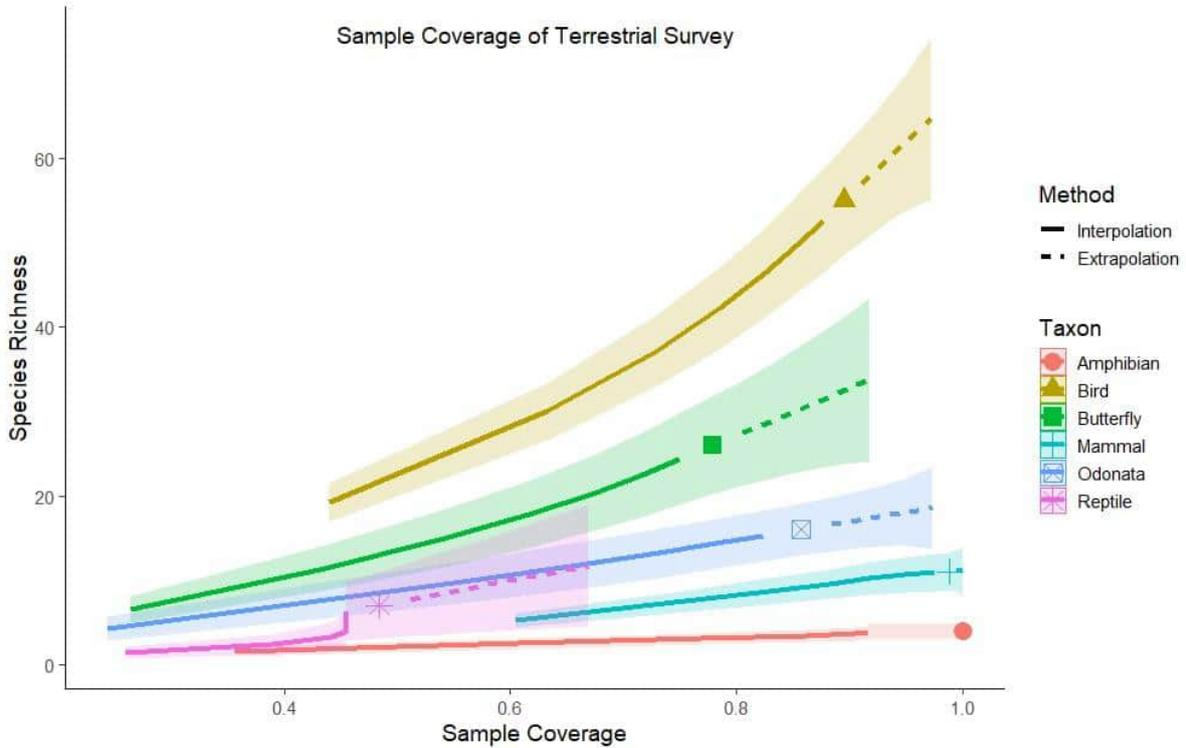

Figure 6-28 Sample coverage curves for each taxon for each survey method.

6.4 Assessment of Ecological Values

Habitats and species within the Study Area were assessed for their ecological value. Habitats and species accorded with higher ecological value were regarded of greater importance for conservation relative to other habitats and species, respectively, within the Study Area. Those of high ecological value were assigned the Priority 1 sensitivity level, while those of moderate or low ecological value were assigned the Priority 2 or 3 sensitivity levels, respectively. The assessment was carried out using biodiversity baseline findings.

The ecological value assessment framework for habitats is described in Table 6-8 and Table 6-9 [R-34; R-35].

Table 6-8 Criteria for assessing the ecological value of habitats.

Criterion	Definition	Classification		
		High	Medium	Low
Size	Area occupied by the habitat relative to the study area or length of a stream	≥ 40%	10–40%	≤ 10%
Naturalness	Degree to which the habitat has been modified or disturbed as a result of human activities	Habitat with minimal human disturbance	Moderately disturbed habitat that has been modified to some extent	Highly disturbed habitat that has been modified to a large extent
Abundance of species of conservation significance	Number of plant specimens recorded within the habitat relative to the Study Area; number of recorded faunal species of conservation significance that able to utilise the particular habitat type in the Study Area	≥ 40%	10–40%	≤ 10%
Abundance of large and other plant specimens of value	Number of large and other plant specimens of value recorded within the habitat relative to the Study Area	≥ 40%	10–40%	≤ 10%
Ecological linkage	The value of a habitat increases if it lies in close proximity and/or links functionally to a highly valued habitat of any type.	Able to connect to high valued habitats within the study Area.	Able to connect to habitats within the Study Area.	Not able to connect to habitats within the Study Area/Isolated.
Difficulty in recreatability	Level of difficulty in re-constructing the habitat through human intervention	Very difficult	Moderately difficult	Easy

All plant species were first accorded with a tentative ecological value, i.e., high, medium, or low, based on the following basic framework:

- High ecological value (Priority 1): Species of conservation significance
- Medium ecological value (Priority 2): All other native species
- Low ecological value (Priority 3): Exotic and cryptogenic species

Species that were tentatively assigned medium (all other native species) or low (exotic and cryptogenic species) ecological value were then evaluated individually based on the criteria listed in Table 6-9. The evaluation of

individual species served to either maintain or raise the pre-assigned ecological value. The following paragraphs detail how each criterion was considered in the evaluation.

Association with important fauna (native, exotic, and cryptogenic species): The ecological value of plant species that directly support the growth and survival of important fauna at one or various life cycle stages were raised to high, irrespective of plant species origin, cultivation intensity and effects, as well as national distribution. Examples of such plant species include caterpillar host plants for rare butterfly species and bamboos that are refugia for nationally threatened bamboo bats. The ecological value of plant species without associations with important fauna was maintained at the original level, i.e., medium or low.

Cultivation intensity and effects (native species only): The ecological value of all native species previously or presently cultivated and/or with populations of relics or escapees, respectively, present in the secondary forests of Singapore were maintained at the medium level. Otherwise, those that are associated with important fauna were raised to high ecological value.

National distribution (non-cultivated native species only): The ecological value of non-cultivated native plant species with restricted national distribution—i.e., largely found in certain forest patches in Singapore or offshore islands, such as the primary and old growth secondary forests of the CCNR—were raised from the original medium level to high. On the other hand, of non-cultivated plant species that are nationally widespread—i.e., occur at several secondary forest patches throughout Singapore—were maintained at the medium level.

There are, however, a few exceptions in which the highest ecological value was automatically assigned to species regardless of the criteria listed below. They are (1) species endemic to Singapore, (2) keystone fig (*Ficus* sp.) and mangrove species as they fruit all year round and provide a steady source of food for frugivores [P-48] and (3) species planted for reforestation and/or previously thought to be extinct and are planted for species reintroduction. Additionally, the exotic rain tree (*Samanea saman*) was also automatically raised from low to medium ecological value given that it often supports the growth of epiphytes that provide habitats for fauna species.

Table 6-9 Criteria for assessing the ecological value of plant species.

Criterion	Definition
Conservation Significance	Listed as nationally threatened, i.e., Vulnerable, Endangered, Critically Endangered, or Extinct, and are considered of conservation significance in this study
Association with Important Fauna	Directly associated with the survival of important fauna at one or various life cycle stages
Cultivation Intensity and Effects	Cultivated previously or presently—for various purposes such as reforestation, landscaping, species reintroduction, commercial sale, etc—and populations of relics and/or escapees are present/absent in forests
National Distribution	Extent of spread and/or occurrence at one or multiple forest patches in Singapore

All recorded faunal species were accorded an ecological value based on its conservation significance and species origin:

- High ecological value (Priority 1): Species of conservation significance
- Medium ecological value (Priority 2): All other native species
- Low ecological value (Priority 3): Exotic and cryptogenic species

6.4.1 Habitat

The ecological value of three terrestrial habitats and two aquatic habitats within the Study Area was assessed. For the assessment of terrestrial habitats, the abundance of flora species of conservation significance and habitat preference of terrestrial faunal were considered, and likewise for the assessment of aquatic habitats. No large plant specimen was recorded from aquatic habitats, however, a small patch (0.078 ha) of spoon seagrass (*Halophila ovalis*) was found in the soft-sediment seabed habitat in Pond 2.

The mature mangrove at Pond 1 was assessed to have an overall high ecological value, i.e., Priority 1. One terrestrial habitat (abandoned-land forest) was assessed to have overall medium ecological value, i.e., Priority 2.

One terrestrial habitat (scrubland and herbaceous vegetation) was assessed to have overall low ecological value, i.e., Priority 3. A summary of the assessment of ecological value is detailed in Table 6-10. The paragraphs below summarise the ecological value for each habitat type.

I. Mangrove (High Ecological Value; Priority 1)

The mangrove forest occupies 3.6 ha (22.52%) of the Study Area. Both of these areas are not accessible to the public and will remain so after mangrove restoration is complete, scoring the habitat high on 'Naturalness'. The nationally Vulnerable nipah palm (*Nypa fruticans*) was observed to be the dominant species behind Jalan Durian. In addition, scattered individuals of species of conservation significance including *Ceriops zippeliana* and terentum bunga putih (*Lumnitzera racemosa*) were found within the mature mangrove stand east of Pond 1.

Given the presence of high numbers of vulnerable native species and the mature mangrove habitat that is difficult to replicate, we assessed this habitat to have high ecological value based on the criteria of 'Abundance of species of conservation significance' and 'Difficulty in recreability'. With three of five criteria assessed to be 'high', the overall ecological value of the habitat is high, i.e. Priority 1.

II. Soft-sediment Seabed (Medium Ecological Value; Priority 2)

The soft-sediment seabed occupies 3.7 ha (23.13%) of the Study Area, giving it a "medium" for size criteria. Due to the past land use history of the disused ponds as prawn farms, this habitat is considered moderately disturbed that has been modified to some extent. There was a low abundance of fauna species of conservation significance (three species) and in part due to past disturbance from the prawn farm. Within the soft-sediment seabed area in Pond 2, a small, scattered seagrass patch—with only one species, *Halophila ovalis*—of 0.078 ha was observed and is considered a specimen of value. The soft-sediment seabed is also considered highly connected as it gets an influx of seawater during high tide—this can bring in mangrove propagules to aid the restoration of mangroves within the disused ponds. Such soft-sediment seabed habitats are easy to recreate.

With three criteria assessed to be medium, one assessed to be high and the last assessed to be low, the overall ecological value of soft-sediment seabed is medium, i.e., Priority 2.

III. Abandoned-land Forest (Medium Ecological Value; Priority 2)

The abandoned-land forest occupies 3.88 ha (24.33%) of the Study Area, the largest single habitat on site. Despite the presence of infrastructures (0.33 ha) and residents present within the abandoned-land forest, it is scored medium on 'Naturalness' since this area is hardly accessed by the public and infrastructure can be considered of low impact. This habitat is high in abundance of conservation significant species which were observed across the site. This habitat also has high abundance of common native secondary forest trees. All four significant large trees of girth >3 m within the Study Area were found within the abandoned-land forest.

This habitat type also supported the largest number of conservation significant fauna species including the nationally extinct and rediscovered Malayan nawab (*Polyura moori moori*) and a few nationally critically endangered species that are rare or extinct on mainland Singapore, for example, the white-bellied blind snake (*Argyrophis muelleri*), greater mousedeer (*Tragulus napu*) and leopard cat (*Prionailurus bengalensis*).

Since an abandoned-land forest needs time for regrowth, the 'Difficulty in recreability' is ranked as 'medium'. Given that this habitat is connected to the high value mature mangrove stand, it is ranked 'medium' for 'Ecological linkage' and assessed to have an overall ecological value of 'medium', i.e. Priority 2, with all five criteria assessed to be medium.

IV. Scrubland and Herbaceous Vegetation (Medium Ecological Value; Priority 2)

The scrubland habitat is found mostly atop the bunds of the disused ponds and in linear patches within the site, occupying a total area of 1.17ha (7.35%), making it the smallest habitat type after infrastructure. A small number of conservation significant plants and no significant large specimens were found within this habitat type. Although some conservation significant fauna were found utilising the scrubland, birds and butterflies consisted the bulk of them and since they are highly mobile species, they likely came from adjacent habitat types. Therefore, this area is assessed to be of 'medium' priority for 'Abundance of species of conservation significance' and 'medium' value

in 'Ecological linkage', since it is adjacent to both the high value mangrove and mudflat habitat and medium value abandoned-land forest and likely to be a connecting habitat.

Grasses and shrubs that make up the scrubland colonise rapidly and can take over land with minimal human intervention, allowing for increased ease of recreatability, hence a 'low' ecological value.

With two criteria assessed to be low and three assessed to be medium, the overall ecological value of scrubland and herbaceous vegetation is medium, i.e., Priority 2.

V. Marine area (Medium Ecological Value; Priority 2)

The Marine Area occupies 3.29 ha (20.60%) of the Study Area, giving it a "medium" for size criteria. Due to the presence of a fish farm in the vicinity and past land use history of the disused ponds as prawn farms, this habitat is considered moderately disturbed that has been modified to some extent. There was a low abundance of fauna species of conservation significance, partially also due to the low number of sampling points. There are no species of conservation significant flora species. The Marine Area is also considered highly connected and easy to recreate.

With two criteria assessed to be low, two assessed to be medium and one assessed to be high, the overall ecological value of the Marine Area is medium, i.e., Priority 2.

Table 6-10 Summary of ecological value of habitats recorded with Study Area.

Criterion	Mangrove	Soft-sediment seabed	Abandoned-land forest	Scrubland and herbaceous vegetation	Marine area
Size	Medium: 22.58% (3.60 ha)	Medium: 23.13% (3.70 ha)	Medium: 24.33% (3.88 ha)	Low: 7.35% (1.17 ha)	Medium: 20.60% (3.29 ha)
Naturalness	High: Habitat with minimal human disturbance	Medium: Moderately disturbed habitat that has been modified to some extent	Medium: Moderately disturbed habitat that has been modified to some extent	Medium: Moderately disturbed habitat that has been modified to some extent	Medium: Moderately disturbed habitat that has been modified to some extent
Abundance of species of conservation significance	High: Flora: 27% (14) Fauna: 50% (9)	High: Fauna: 100% (3)	Medium: Flora: 69% (36) Fauna: 39% (7)	Medium: Flora: 38% (20) Fauna: 61% (7)	Low: Flora: 4% (2) Fauna: 17% (3)
Ecological linkage	Medium: Moderately connected	Medium: Moderately connected	Medium: Moderately connected	Medium: Moderately connected	High: Highly connected
Ease of recreatability	High: Very difficult	Low: Easy	Medium: Moderately difficult	Low: Easy	Low: Easy
Total	High × 3 Medium × 2 Low × 0	High × 1 Medium × 3 Low × 1	High × 0 Medium × 5 Low × 0	High × 0 Medium × 3 Low × 2	High × 1 Medium × 2 Low × 2
Sensitivity	Priority 1	Priority 2	Priority 2	Priority 2	Priority 2

6.4.2 Flora

A total of 195 plant species (including one seagrass species) were assessed for their ecological value in the overall Study Area. 67 plant species were accorded a Priority 1 sensitivity level with high ecological value—of which 14 Priority 2 species were raised to Priority 1 as they were considered specimens of value (i.e. seagrass, mangroves

or large specimens). While 71 species to be of Priority 2 sensitive level, with medium ecological value, and 57 species with a Priority 3 sensitivity level, with low ecological value.

6.4.3 Fauna

The ecological value of 285 faunal species—128 terrestrial species and 157 aquatic species — recorded from the baseline assessment were assessed. All 19 faunal species (3 marine and 16 terrestrial) of conservation significance were accorded a Priority 1 sensitivity level and deemed to be of high ecological value. For terrestrial species, 97 species were assessed to be of Priority 2 sensitive level, with medium ecological value, and 17 species with a Priority 3 sensitivity level, with low ecological value. For marine species, 21 species were assessed to be of Priority 2 sensitive level, with medium ecological value, and 133 species with a Priority 3 sensitivity level, with low ecological value.

6.5 Potential Sources of Biodiversity Impacts

This section discusses possible biodiversity impacts arising from the construction and operational phases of the Project, based on the proposed construction and operational activities.

Main construction activities (i.e. backfilling of disused ponds to desired soil levels) should be confined to the disused ponds. There is a possibility of indirect impacts in terms of sedimentation plume to the surrounding marine areas due to the high connectivity of the waterways. However, no major indirect impacts (i.e., habitat degradation) are expected to occur within the terrestrial environment from the backfilling works. Additionally, there will be some localised works within the terrestrial environment from the construction of low impact infrastructures such as the pavilion, bicycle racks and look our points with education signages. This will likely involve some clearance of vegetation and excavation in the terrestrial habitats. After which, post-construction activities include removal of construction materials and vehicles, withdrawal of personnel and daily operations.

At the operational phase, despite opening the areas up to public, there should not be a significant increase in human traffic/disturbance to the Study Area. Disturbance will predominantly come from increased anthropogenic noise, human activity and presence of built structures.

The impacts for the construction and operational phases were separately assessed for biodiversity sensitive receptors identified in Section 6.6, with a description of potential impacts given in Section 6.8. There are two main categories in which the impacts fall into: (1) direct, i.e., impacts to habitats and species within the worksites and (2) indirect, i.e., impacts to habitats and species outside the worksites but within the impact zone. Impact zones for habitat and plant species receptors are defined as areas within 30 m from worksites of the proposed development [P-43, P-44, P-45, P-46].

The 30-m impact zone is based on the assumption that edge effects in habitats directly adjacent to worksites are the greatest within 30 m from the worksites. While the indirect impact zone for fauna species will consider the entire Study Area as fauna species are mobile and are likely to move throughout the Study Area.

The list of potential environmental impacts during construction and operational phase is summarised in Table 6-11.

Table 6-11 List of potential ecological impacts during construction and operational phases.

Receptor	Impact Type	Description
Construction Phase		
Habitats	Loss of vegetation/habitat	Direct removal of vegetation (with extensive underground root systems that protect against soil erosion)/habitat to create space for construction activities and/or development
	Habitat degradation	Improper disposal of construction waste, accidental release of hazardous materials (such as construction slurry, paint, and/or solvents), increase in dust, noise, and light levels, changes in hydrology
Plant Species	Mortality	Direct removal of vegetation to create space for construction activities
	Decline in plant health and survival	Changes in microclimatic conditions (i.e., dust, noise, and light, temperature, and humidity) and hydrology

Receptor	Impact Type	Description
Faunal Species	Accidental injury or mortality	Collisions with machineries, entrapments in construction materials (such as non-biodegradable erosion control blankets) and structures (such as exposed pits or drains), and accidental kills by construction personnel, including roadkills
	Loss/reduction of ecological connectivity for faunal movement	Habitat fragmentation from the removal of vegetation
	Human-wildlife conflict	Negative consequences of human-wildlife interactions, such as deliberate killing and depopulation of faunal species perceived as nuisances or threats by construction personnel
	Human disturbances	Increase in human traffic flow, such as workers and site personnel
Operational Phase		
Habitat	Habitat degradation	Trampling on vegetation, pollution (e.g., contamination of surface waterbodies, dust, litter) from increased human activities
Faunal	Human-wildlife conflict	Negative consequences of human-wildlife interactions, such as deliberate killing and depopulation of faunal species perceived as nuisances or threats by members of the public
	Human disturbances	Increase in human traffic flow, such as residents and visitors



Conservation Significant Flora Species

- Critically endangered
- Endangered
- Vulnerable

Legend

 Filled Area	 Scrubland
 Overall EIS Study Area	 Soft sediment seabed
 Mangrove	 Marine area
 Seagrass	 Infrastructure
 Abandoned-land forest	 30m impact zone

Rev.	Date	By	Description	Chk'd	App'd
-	DEC 2022	SS	EIA Report	NHT	JAG

Qualified Person Endorsement : NA

NParks Endorsement : NA

Consultant : **AECOM**

Project Title :
**CONTRACT NPARKS/N/39/2017
 CONSULTANCY SERVICES FOR SHORELINE
 WORKS IN PULAU UBIN
 (MANGROVE RESTORATION OF
 SUNGEI DURIAN PONDS)**

Designed SS	Checked NHT	Approved JAG
Drawn SS	Date DEC 2022	

Client:

Figure Title:
Impact zone for habitat and plant species receptors

Figure No. : 6-29	Rev. : -	Sheet : 1 of 1
CAD File Name : NA		A3

6.6 Identification of Biodiversity Sensitive Receptor

6.6.1 Habitats

Following the assessment of ecological value for habitats (Section 6.4.1), all habitats within the worksite and within 30 m from the proposed worksite area were identified as the sensitive receptors for habitats (Figure 6-29).

6.6.2 Flora

Following the assessment of ecological value for all plant species (including seagrasses) (Section 6.4.2), some were selected for the assessment of ecological impacts. The selection was based on the following: (1) species with specimens of conservation significance, large specimens, other specimens of value, and/or trees found inside within 30 m of the proposed worksite area, (2) keystone species, which are the fig, mangrove and seagrass in this study and (3) species associated with important fauna.

A total of 45 species were selected for the assessment of ecological impacts, of which 27 species are of conservation significance and recorded within the 30-m impact zone, four were large specimens, 13 common mangrove species and one seagrass species located within Pond 2. There were a total of 108 specimens recorded within the impact zone—14 specimens (six species) of national Critically Endangered status, 33 specimens (7 species) of national Endangered status and 61 specimens (14 species) of national Vulnerable status. Five species had overlapping criteria of conservation significance, recorded within the 30-m impact zone and a mangrove species. These species were *Ceriops tagal*, *Ceriops zippeliana*, *Lumnitzera littorea*, *Lumnitzera racemosa* and *Nypa fruticans*.

6.6.3 Fauna

Following the assessment of ecological value for faunal species (Section 6.4.3), all species with a Priority 1 sensitivity level were identified as the sensitive receptors. Species of conservation significance deemed of probable occurrence were also identified as sensitive receptors (Appendix E).

A total of 163 sensitive receptors were identified, of which 19 were recorded from the field assessment, and 155 were deemed of probable occurrence. Breaking down the sensitive receptors by taxon, there are 26 butterflies, two odonates, nine reptiles, 33 birds, 12 non-volant mammals, nine bats, 13 fishes, 19 decapod crustaceans, four echinoderms, 23 molluscs, eight marine worms, three cnidarians, and two xiphosurids (Appendix H).

6.7 Minimum Control Measures

This section lists biodiversity-specific minimum controls commonly implemented in Singapore for similar construction and operational activities. Minimum controls for each potential impact occurring from the construction and operational phases are listed in Table 6-12. These measures should be proposed in tandem with other environmental receptors (e.g., air and noise).

Table 6-12 Description of minimum controls implemented at construction and operational phases.

Work Activities	Minimum Controls
Construction phase	
General	<ul style="list-style-type: none"> • Install terrestrial hoarding 300mm into the ground to prevent wild boar intrusion and to delineate worksite; • Avoid fogging by implementing preventive measures for mosquito to remove sources of stagnant water or water-bearing receptacles; • Providing well-maintained pitched roof, clearing discarded items daily, store materials appropriately, level up ground depression/uneven surfaces, ensure effective drainage flow; • Provide a designated eating area (preferably indoors) and prevent access of Eurasian wild boar, long-tailed macaque and rats to food waste by provisioning wildlife-proof bins for food waste disposal;

Work Activities	Minimum Controls
	<ul style="list-style-type: none"> • Daily checks by Environmental Manager on site, to ensure compliance and to check for trapped/ injured/ dead fauna; • Execute wildlife response plan when a trapped/ injured/ dead/ dangerous animal is encountered around or within the worksite according to Section 10 of Wildlife Act [R-32]; and • A biodiversity awareness training should also be conducted for all personnel on site to ensure that they are aware of fauna response and rescue protocol.
Vegetation Clearance	<ul style="list-style-type: none"> • Set up Tree Protection Zones (TPZs) around trees or other plant specimens to be retained within the worksites, within which no construction works are allowed. This should be executed by certified arborists and in accordance with NParks' guidelines [R-33]. • Conduct inspections of fauna prior to felling or removal of vegetation. This should be done by an ecologist who is able to identify wildlife and/or active nesting structures, such as bird nests, tree hollows and/or burrows, and bamboo clusters. • Implement soil erosion control measures as soon as vegetation has been removed and soil is exposed (refer to Section 7 on Marine Water).
Earthworks (Excavation, above and below ground construction) and general construction activities including backfilling	<ul style="list-style-type: none"> • Implement soil erosion control measures (refer to Section 7 on Surface Water Quality). • Ensure proper storage of materials likely to leach harmful chemicals and fuel-powered equipment by storing them away from waterbodies and/or sensitive habitats (refer to Section 7 on Marine Water).
Operational phase	
General	<ul style="list-style-type: none"> • Ensure noise levels are within approved limits. • Ensure dust levels are within approved limits. • Avoid fogging by implementing preventive measures for mosquito to remove sources of stagnant water or water-bearing receptacles, e.g., Providing well-maintained pitched roof, clearing discarded items daily, store materials appropriately, level up ground depression/uneven surfaces, ensure effective drainage flow.

6.8 Prediction and Evaluation of Biodiversity Impact

In this section, the identified biodiversity sensitive receptors were evaluated based on impact intensity and likelihood, in order to derive the impact significance. The various levels of impact intensity and likelihood for each impact type during the construction and operational phases were defined for the biodiversity sensitive receptors. Some assumptions were made in defining the levels of impact intensity, and are detailed in the respective sections below.

For both construction and operational phases, the full list of the priority level, impact intensity, impact consequence, impact likelihood, as well as the resulting impact significance for all biodiversity sensitive receptors is provided in Appendix H.

6.8.1 Positive Impacts

Ecological mangrove restoration (EMR) encourages the natural establishment of mangrove with prior understanding of site conditions and is superior to mangrove sapling planting, which is prone to failure and limited biodiversity; successful projects include places such as Thailand and Indonesia [W-25]. However, this method will involve a longer period of recovery as site conditions are being reconstructed to favourable tidal inundation and substrate levels by improving the local hydrology and promoting sediment accretion.

Given the nature of EMR, short-term loss and degradation of habitats, limited decline in flora health and fauna mortality are to be expected during the construction phase. However, with the creation of a high-valued mangrove habitat in place of the extant soft-sediment seabed, overall net gain in biomass and diversity is expected to surpass the current state at the point of project completion in the operational phase.

6.8.2 Construction Phase

The definitions for impact intensity and likelihood of occurrence for habitat receptors are given in Table 6-13 and Table 6-14 respectively. Two assumptions were made in defining the levels of impact intensity and the likelihood of direct and indirect impacts for habitat receptors:

1. Habitats within 30 m from the worksites are assumed to experience the greatest extent of edge effects (refer to Section 6.5 for the definition of impact zone).
2. The likelihood of habit degradation is presumed to be **Less Likely** for habitat receptors, based on the assumption that all minimum controls (Section 6.7) are adequately and properly implemented.

Table 6-13 Definitions of each level of impact intensity for habitat receptors during construction.

Impact Type	Negligible	Low	Medium	High
Loss of vegetation/habitat	The habitat does not overlap with the worksites	≤ 10% of the habitat overlaps with the worksites	10–40% of the habitat overlaps with the worksites	> 40% of the habitat overlaps with the worksites
Habitat degradation	The habitat does overlap with areas 30 m from the worksites	≤ 10% of the habitat overlaps with areas 30 m from the worksites	10–40% of the habitat overlaps with areas 30 m from the worksites	> 40% of the habitat overlaps with areas 30 m from the worksites

Table 6-14 Definitions of each level of likelihood for habitat receptors during construction.

Likelihood	Loss of Vegetation	Habitat Degradation
Unlikely/Remote	The habitat does not overlap with the worksites	N.A.
Less Likely/ Rare	N.A.	N.A. (see assumption above)
Possible/ Occasional	N.A.	N.A.
Likely/ Regular	N.A.	N.A.
Certain/ Continuous	The habitat overlaps with the worksites	N.A.

The definitions for impact intensity and likelihood of occurrence for flora receptors are given in Table 6-15 and Table 6-16 respectively. One assumption was made in defining the levels of impact intensity for plant and seagrass species receptors during the construction phase:

1. Habitats within 30 m from the worksites are assumed to experience the greatest extent of edge effects, though some studies have shown that edge effects could be up to 150 m (refer to Section 6.5 for the definition of the impact zone). The effects of forest edges may be experienced by species more sensitive to microclimatic changes more than 30 m away from the worksites; these are considered during species-specific impact evaluations.

Table 6-15 Definitions of each level of impact intensity for flora receptors during construction.

Impact Type	Negligible	Low	Medium	High
Mortality	No plant specimens of this	Less than 50% of all plant specimens	More than or exactly 50% of all	All plant specimens of this

Impact Type	Negligible	Low	Medium	High
	species are within the worksites	of this species are within the worksites	plant specimens of this species are within the worksites	species are within the worksites
Decline in plant health and survival	No specimens of this species are within 30 m from the worksites	Less than 50% of all plant specimens of this species are within 30 m from the worksites	More than or exactly 50% of all plant specimens of this species are within 30 m from the worksites	All specimens of this species are within 30 m from the worksites

Table 6-16 Definitions of each level of likelihood for flora receptors during construction.

Likelihood	Mortality	Decline In Plant Health And Survival
Unlikely/Remote	No plant specimens of this species are within the worksites	No formation of forest edges (i.e., construction activities are fully underground and/or in existing built-up areas outside the forest)
Less Likely/ Rare	N.A.	Formation of scrubland edges in scrubland areas only
Possible/ Occasional	No count data and/or locations of specimens of this species is available, but specimens could possibly be within the worksites	Formation of some forest and scrubland edges in a mix of urban vegetation, scrubland and forested areas
Likely/ Regular	N.A.	Formation of new forest edges (i.e., complete clearance within forested areas)
Almost Certain/ Continuous	Plant specimens of this species are within the worksite	N.A.

The definitions for impact intensity and likelihood for faunal species are presented in Table 6-17 and Table 6-18 respectively.

Table 6-17 Definitions of each level of impact intensity for faunal receptors during construction.

Impact Type	Negligible	Low	Medium	High
Accidental injury or mortality	Species with negligible susceptibility to accidental injury/mortality from construction activities (large vehicles, excavation, piling, etc.) and roadkills	Species with low susceptibility to accidental injury/mortality from construction activities (large vehicles, excavation, piling, etc.) and roadkills: – Volant species (e.g., odonates, butterflies, highly volant birds, raptors and most bats) – Aquatic species (most fishes, crabs, shrimps)	Species that are mobile but possibly susceptible to accidental injury/mortality from construction activities (large vehicles, excavation, piling, etc.) and roadkills: – Less volant birds – All amphibians – Some mammals (e.g., squirrels, shrews)	Species with high susceptibility to accidental injury/mortality from construction activities (large vehicles, excavation, piling, etc.) and roadkills: – Reptiles – Some mammals (e.g., Sunda pangolin, long-tailed macaque, smooth otter) – Migratory birds – Nesting birds – Bamboo bats

Impact Type	Negligible	Low	Medium	High
Human-wildlife conflict	Species that are not perceived as nuisances or threats by construction personnel – Odonates – Butterflies – Most birds – Aquatic species	Species that are possibly perceived as both nuisances and threats by construction personnel, less tolerant of human presence and urban environments: – Some reptiles – Most amphibians – Most bats	Species that are typically perceived as nuisances and possibly as threats by construction personnel, highly tolerant of human presence and urban environments, and frequently implicated in human-wildlife conflict: – Smooth otter – Aculeate hymenopterans	Species that are typically perceived as both nuisances and threats by construction personnel, highly tolerant of human presence and urban environments, and are frequently implicated in human-wildlife conflict: – Long-tailed macaque – Some snakes
Loss of/reduction in of ecological connectivity for faunal movement	Not dependent on connected habitats for dispersal and able to traverse urban infrastructure	Slightly dependent on connected habitats for dispersal and adaptable to traverse urban infrastructures if needed	Dependent on connected habitats for dispersal	Highly dependent on connected habitats for dispersal
Human disturbances	Species that are not sensitive to human presence	Species that are slightly sensitive to human presence	Species that are sensitive to human presence	Species that are extremely sensitive to human presence, and nesting birds

Table 6-18 Definitions of each level of likelihood for faunal receptors during construction.

Likelihood	Loss of/ reduction in habitats and food sources	Accidental injury or mortality	Human-wildlife conflict	Loss of/ reduction in ecological connectivity for faunal movement	Light disturbances	Human disturbances
Unlikely/Remote	Impact is not expected to happen during the construction phase of the project					
Less Likely/Rare	Impact is not likely to happen during the construction phase of the project					
Possible/Occasional	Impact could possibly happen or known to occur during the construction phase of the project					
Likely/Regular	Impact is a common occurrence during the construction phase of the project					
Almost Certain/Continuous	Impact is a continual or repeated process during the construction phase of the project					

6.8.2.1 Habitats

Three construction phase impacts were identified and assessed for the habitat receptors: (1) loss of vegetation and (2) habitat degradation. The impact significance ranged from **Negligible** to **Major**. A summary of the key biodiversity habitat receptors impacted during construction phase is shown in Table 6-19.

Loss of vegetation/habitat

There will be some vegetation clearance within the abandoned-land forest and scrubland herbaceous vegetation for the construction of amenities/facilities such as the pavilion, bicycle racks and look our points with education signages. As area cleared is less than 10% of the habitat, intensity and likelihood will be **Low** and **Certain**

respectively. This results in **Minor** impact significance for abandoned-land forest and scrubland herbaceous vegetation.

Though vegetation clearance will not occur within the soft-sediment seabed, this habitat will be lost due to backfilling of more than 40% of Pond 2 and 3 to achieve desired soil levels and restore ideal conditions for mangrove establishment. Therefore, intensity will be **High** and likelihood will be **Certain**, resulting in **Major** impact significance for the low value soft-sediment seabed habitat, which will in future be replaced with a mangrove habitat of high ecological value.

Subsequently, though it is not expected to have vegetation/habitat loss within the mangrove habitat, it is likely that mangrove trees lining the edge of the Ponds be affected indirectly by the backfilling works. This impact will be addressed in Section 6.8.2.2.

Lastly, as there is no need for vegetation clearance or habitat loss in the other habitats, intensity and likelihood will be **Negligible** and **Unlikely** respectively. This results in **Negligible** impact significance for all other habitats within Study Area.

Habitat degradation

For scrubland and herbaceous vegetation and abandoned-land forest, 16% and 41% of the habitat overlaps with areas 30 m from the worksites respectively. However, as the construction works will be confined within the disused ponds, the likelihood of habitat degradation is presumed to be **Unlikely**, resulting impact significance is **Minor**.

However, habitat degradation in the marine environment (i.e., soft-sediment seabed and Marine Area) in terms of sedimentation works differently from the terrestrial system. Any sediment dislodged would affect the surface water quality and impact downstream habitats. Habitat degradation for the marine environment within the Study Area was therefore raised to **Likely** for soft-sediment seabed habitat and Marine Area which are assumed to be interconnected, resulting in an impact significance of **Moderate**. Despite sedimentation in the construction stage, the restored mangrove will reduce surrounding sedimentation in the long run via its tendency to accrete sediment.

Table 6-19 Summary of construction phase impacts to habitat receptors during construction phase.

Habitat receptor	Priority level and other relevant status	Direct impact (% of total habitat type within Study Area)	Indirect impact (% of total habitat type within Study Area)	Most Severe Impact Rating
Mangrove	Priority 1	NA	1.37 ha (37.94%)	Negligible
Soft-sediment seabed	Priority 2	2.99 ha (80.81%)	NA	Major
Abandoned-land forest	Priority 2	NA	0.62 ha (16.08%)	Minor
Marine area	Priority 2	NA	NA	Minor
Scrubland and herbaceous vegetation	Priority 2	NA	0.48 ha (41.03%)	Minor

6.8.2.2 Flora

Two construction phase impacts were identified and assessed for flora receptors: (1) mortality and (2) decline in plant health and survival. The impact significance ranged from **Negligible** to **Moderate**.

A total of 45 sensitive plant species receptors recorded in the Study Area were selected for the assessment of ecological value impacts. The most substantive impact for both flora impact types was **Moderate**. A summary of all the impacts to flora receptors are provided in Table 6-20.

Moderate impact in mortality is expected for seagrass species *Halophila ovalis* as the backfilling of Pond 2 would result in mortality of a small seagrass patch of 0.078 ha. As *H. ovalis* is a common species, it was accorded medium sensitivity. This coupled with **Moderate** intensity and a **Certain** for Likelihood resulted in a Moderate impact significance. Intensity was considered **Moderate** as the seagrass patch was small and scattered. Relative to the

large seagrass meadows at Chek Jawa, the loss of seagrass within Pond 2 is also likely not to affect it. Additionally, the establishment of a mangrove is expected to positively influence adjacent seagrass meadows such as Chek Jawa, due to their synergistic relationship [P-61; P-62; P-63].

Subsequently, the backfilling works within the disused ponds will result in possible mortality, if not likely cause a decline in the plant health for mangrove species— *Lumnitzera racemosa*, *Ceriops zippeliana*, *Lumnitzera littorea* and *Ceriops tagal*, and because these species have more than 50% of all plant specimens of this species within 30 m from the worksites, a **Medium** for intensity was accorded. Together with likelihood of **Likely**, impact significance of **Moderate** is expected. However, it is worthy to note that though plant specimen along the edge of the Pond 3 and 2 will likely be indirectly affected by the backfilling works in the short-term, benefits from the recovery and further recruitment of mangrove plants are expected in the long-term.

Finally, as works are confined to within the disused ponds, all other species though present within the 30-m impact zone—if not within the disused ponds or along the edge of the disused ponds—should not be impacted directly through mortality or indirectly through decline in plant health.

Table 6-20 Summary of construction phase impacts to flora receptors during construction phase.

Impact Type	No. of Species			
	Major	Moderate	Minor	Negligible
Mortality	0	1	4	40
Decline in plant health*	0	4	-	40

* As seagrass assumed to be removed from backfilling, assessing for decline in plant health is not applicable. Therefore, total number of flora receptors for impact type “Decline in plant health” only adds up to 44.

6.8.2.3 Fauna

Four construction phase impacts were identified and assessed for faunal receptors: (1) loss of/reduction in ecological connectivity for faunal movement, (2) accidental injury or mortality, (3) human-wildlife conflict, (4) human disturbances. The impact significance ranged from **Negligible** to **Moderate**. The more substantial impacts arising from each impact type are briefly summarised below. A summary of the impact on fauna receptors is given in Table 6-21.

Table 6-21 Summary of construction phase impacts to fauna receptors.

Impact Type	No. of Species			
	Major	Moderate	Minor	Negligible
Loss/reduction of ecological connectivity for faunal movement	0	0	0	163
Accidental injury or mortality	0	61	0	102
Human-wildlife conflict	0	3	7	153
Human disturbances	0	19	9	135

Loss of/or reduction in ecological connectivity for faunal movement

The backfilling of existing soft-sediment seabed (disused ponds) habitat may hinder the movement of existing organisms in the surrounding habitat. However, the likelihood of the loss of or reduction in ecological connectivity for faunal movement was deemed to be **Unlikely** for all species, including marine species which may utilise the surrounding marine environment for dispersal. The impact significance is hence **Negligible** for all species receptors.

Accidental injury or mortality

The backfilling of existing soft-sediment seabed (disused ponds) habitat may result in accidental injury or mortality of fauna during the construction phase and thus was deemed to be **Likely** for species that predominantly utilises the soft-sediment seabed such as molluscs and crustaceans, resulting in **Moderate** impact significance. Species that also utilise the soft-sediment seabed but are potentially more mobile such as the Xiphosurid species will still be unable to move away in time and are still **Likely** to be impacted by backfilling, especially if sediments are deposited at high rates. The rest of the species (59) not predominantly utilising the soft-sediment seabed are **Unlikely** to be impacted in terms of accidental injury or mortality.

Human-wildlife Conflict

Human-wildlife conflict between faunal species and construction site personnel was deemed to be **Unlikely** for species predominantly utilising the mangrove and disused ponds, **Less Likely** for predominantly ground-dwelling species, and **Possible** for the remainder of species. Human-wildlife interactions may escalate into conflicts for many reasons. Species such as long-tailed macaque (*Macaca fascicularis*) may be attracted to food waste or other materials within the site, and lead to negative interactions with site personnel. A lack of understanding regarding how to safely interact with wildlife may also lead to conflict with these species. Certain species are threats to human safety and may elicit fear in construction personnel when encountered, resulting in conflict. This includes reptiles such as the gold-ringed cat snake (*Boiga melanota*) and king cobra (*Ophiophagus hannah*). The impact significance was hence assessed to be **Moderate** for all above mentioned species.

Human Disturbances

Human disturbance at the construction phase was deemed to be **Unlikely** for non-bird species utilising the mangrove and disused ponds, **Possible** for predominantly ground-dwelling species, and **Less Likely** for the remainder of the species. Most animals are sensitive to human presence and would move away from an approaching human, with extremely sensitive species leaving the site entirely. The impact significance was assessed as **Moderate** for bird species known to forage in the mudflats such as herons (*Ardea* sp.), or surrounding marine habitats, as well as raptor species that may nest in large trees in the area. These species include the crested goshawk (*Accipiter trivirgatus*), grey-headed fish eagle (*Haliaeetus ichthyaetus*), changeable hawk-eagles (*Nisaetus cirrhatus*) and crested serpent eagle (*Spilornis cheela*).

6.8.2.4 Overview

As discussed in the sections above, the evaluation of construction impacts on habitats, flora and fauna are summarised in the Table 6-22.

Table 6-22 Summary of impact evaluation on habitats, flora and fauna receptors.

Receptor Sensitivity	Potential Source of Impacts	Impact Intensity	Consequence	Likelihood	Impact Significance
Habitat (Priority 2 – Priority 1)	Loss of vegetation	Negligible to High	Imperceptible to Medium	Unlikely to Certain	Negligible to Major
	Habitat degradation	Low to High	Very Low to Medium	Unlikely to Likely	Negligible to Moderate
Flora (Priority 2 – Priority 1)	Mortality	Negligible to Medium	Very Low to Low	Unlikely to Certain	Negligible to Major
	Decline in plant health	Negligible to Medium	Very Low to Medium	Unlikely to Likely.	Negligible to Moderate
Fauna (Priority 1)	Loss/reduction of ecological connectivity for faunal movement	Negligible to High	Very Low to High	Unlikely	Negligible

Receptor Sensitivity	Potential Source of Impacts	Impact Intensity	Consequence	Likelihood	Impact Significance
	Accidental injury or mortality	Low to High	Low to High	Unlikely to Likely	Negligible to Moderate
	Human disturbances	Negligible to High	Very Low to High	Unlikely to Possible	Negligible to Moderate
	Human-wildlife conflict	Negligible to High	Very Low to High	Unlikely to Possible	Negligible to Moderate

6.8.3 Operational Phase

The definitions for impact intensity and likelihood of occurrence for habitat receptors are given in Table 6-23 and Table 6-24.

Table 6-23 Definitions of each level of impact intensity for habitat receptors at the operational phase.

Impact type	Negligible	Low	Medium	High
Habitat degradation	Developed area is not accessible to public and no long-term degradation is expected. E.g., core conservation areas with no public access, infrastructure works with no public access	Developed area is designed with the intention for the public to use or visit and will increase human accessibility to the surrounding natural habitats. Limited or controlled degradation is expected near areas of higher human activity. E.g., nature parks	Developed area is designed for members of the public to visit. E.g., parks. Degradation is expected to occur within at least 50% of the habitat	Developed area and surroundings are designed for large groups of people to live or work in the long run. Degradation is expected to occur throughout 100% of the habitat. E.g., residential estates

Table 6-24 Definitions of each level of likelihood for habitat receptors at the operational phase.

Likelihood	Habitat Degradation
Unlikely/Remote	Surrounding natural habitats are not accessible to public
Less likely/Rare	Surrounding natural habitats are accessible but public use is restricted/controlled
Possible/Occasional	Surrounding natural habitats are accessible and have infrastructure for the public to use, such as boardwalks (but people can still stray off track)
Likely/Regular	Surrounding natural habitats are easily accessible and do not have infrastructure for the public to use, such as boardwalks (thus public are off track)
Certain/ Continuous	N.A.

There were no impacts identified to flora at operational phase. Instead—due to the nature of the project—positive impacts are expected and should eventually outweigh the impacts that will be incurred through construction phase. Refer to Section 6.8.3.2 for further information on the expected positive impact of the project.

The definitions for impact intensity and likelihood of occurrence for faunal receptors are given in Table 6-25 and Table 6-26.

Table 6-25 Definitions of each level of impact intensity for faunal receptors at the operational phase

Impact Type	Negligible	Low	Medium	High
Human-wildlife conflict	Species that are not perceived as nuisances or threats by members of the public – Odonates – Butterflies – Most birds – Aquatic species	Species that are possibly perceived as both nuisances and threats by members of the public, less tolerant of human presence and urban environments: – Some reptiles – Most amphibians – Most bats	Species that are typically perceived as nuisances and possibly as threats by members of the public, highly tolerant of human presence and urban environments, and frequently implicated in human-wildlife conflict: – Smooth otter – Red junglefowl – Aculeate hymenopterans	Species that are typically perceived as both nuisances and threats by members of the public, highly tolerant of human presence and urban environments, and are frequently implicated in human-wildlife conflict: – Long-tailed macaque – Some snakes
Human disturbances	Species that are not sensitive to human presence	Species that are slightly sensitive to human presence	Species that are possibly sensitive to human presence	Species that are sensitive to human presence

Table 6-26 Definitions of each level of likelihood for faunal receptors at the operational phase.

Likelihood	Human-wildlife conflict and Human disturbances
Unlikely/Remote	Impact is not expected to happen during the operational phase of the project
Less Likely/Rare	Impact is not likely to happen during the operational phase of the project
Possible/Occasional	Impact could possibly happen or known to occur during the operational phase of the project
Likely/Regular	Impact is a common occurrence during the operational phase of the project
Certain/Continuous	Impact is a continual or repeated process during the operational phase of the project

6.8.3.1 Habitat

One operational phase impact was identified and assessed for habitat receptors: habitat degradation. The impact significance ranged from **Negligible** to **Minor**.

Habitat degradation

Impact intensity for all habitat receptor is deemed to be **Low** as the developed area is designed with the intention for the public to use or visit and will slightly increase human accessibility to the surrounding natural habitats. Controlled degradation is expected as there would be barriers to limit public entry to only localised areas along the bunds. This results in likelihood of habitat degradation to be **Unlikely** for the Marine Area and **Less likely** for mangrove, scrubland and herbaceous vegetation and abandoned-land forest. Therefore, the most substantive impact is **Minor** for mangrove habitat. Soft-sediment seabed habitat was not assessed at operational stage with the assumption that soft-sediment seabed would evolve into a mangrove habitat through EMR.

6.8.3.2 Habitat restoration

Despite the loss of habitat for soft-sediment seabed and likely habitat degradation for Marine Area and soft-sediment seabed during construction period, the overall site condition is expected to be restored and gain biomass and diversity beyond baseline condition over time as it is replaced by a mangrove habitat of high ecological value. While the present mangrove vegetation within/around the disused ponds may deteriorate due to backfilling and a conservation significant mangrove plant (*Lumnitzera racemosa*) may be lost, the mangrove community is expected to regenerate given the known potential for natural recruitment at the Study Area. The resulting mangrove area should be much larger in size and more resilient to sea level rise due to elevated levels with the aid of backfilling and may potentially expand in floral composition over time with opportunistic recruitment of saplings. Human intervention is also viable at this point to aid in increasing floral diversity of the mangrove. The recruitment of a diverse fauna community will then follow the establishment of a resilient mangrove habitat. At present, mangrove stretches are narrow between the disused ponds as they grow only at a suitable inundation level on the bund. With this project achieving the correct substrate height and tidal inundation, the expansion of the mangrove habitat within the disused ponds will improve ecological connectivity for its inhabitants. Additionally, the mangrove will facilitate sediment deposition and reduce sediment erosion into the surrounding marine environment, improving water quality in the long run. Despite the loss of the small seagrass patch in Pond 2 during construction, the establishment of a mangrove is expected to positively influence adjacent seagrass meadows such as Chek Jawa, due to their synergistic relationship [P-61; P-62; P-63]. It is therefore reasonable to assume that all negative impacts will be negated by positive ones in the long-term during the operational stage.

Taking reference from the natural mangrove colonization of regraded reclaimed land at Pasir Ris mangrove, early coloniser species *Avicennia alba* and *Sonneratia alba* may appear as soon as three months after conditions are suitable and may take as short as three years to reach 4 m height (P-57). Succession by *Rhizophora* species was also observed when mangrove sediments reached a depth of 0.6 m (P-58). However, it is to be noted that the study area was small (1ha) and was flanked by mature mangroves and Sungei Tampines, whereas Sungei Durian Ponds are surrounded by less developed mangrove stands and has only a small entry point for inundation and reception of new shoots. The site at Pasir Ris reached a dense stand within five years, while elsewhere in the tropics mangrove expansion rate can reach around 2-4m a year and possibly even faster with appropriate restoration efforts, up to 33-35 ha a year [P-59;P-60] which was achieved by infilling at Pak Phanang, SouthEast Thailand. A similar mangrove restoration project within abandoned prawn farms 33-64 ha in size in Sulawesi, Indonesia recruited two mangrove species within seven months with plant density of 767/ha and reached a density of 2171 plants/ha by the end of 32 months, with seven mangrove species recruited [P-64]. It is likely that Sungei Durian will experience a mangrove colonization rate more similar to that of the local example at Pasir Ris. Given the similarly small size of the ponds at 1.1 and 1.6 ha, Sungei Durian may take around five years to build a sizeable mangrove, but this timeline may be lengthened depending on environmental factors such as availability of new seedlings and ease of establishment in the new environment.

6.8.3.3 Fauna

Two operational phase impacts were identified and assessed for faunal receptors: (1) human-wildlife conflict, (2) human disturbances. The impact significance ranged from **Negligible** to **Moderate**. Only the most substantive impact for each impact type is presented below. A summary of the impact on fauna receptors is given in Table 6-27.

Table 6-27 Summary of operational phase impacts to faunal receptors.

Impact Type	No. of Species			
	Major	Moderate	Minor	Negligible
Human-wildlife conflict	0	1	10	152
Human disturbances	0	0	41	122

Human-wildlife Conflict

The likelihood of human-wildlife conflict during the operational phase was deemed to be **Less Likely** for nesting raptors and terrestrial snakes and **Unlikely** for the rest. The impact significance is assessed to be **Minor – Moderate** for these species.

Human disturbances

Human disturbance at the operational phase was deemed to be **Less likely** for nesting raptor species and birds utilising the mangrove and as well as reptiles and **Unlikely** for the rest. Most species are sensitive to human presence and would move away from an approaching human, with extremely sensitive species leaving the site entirely. Impact significance ranges from **Negligible – Minor**.

6.8.3.4 Overview

As discussed in the sections above, the evaluation of construction impacts on habitats, flora and fauna are summarised in the Table 6-28.

Table 6-28 Summary of impact evaluation on habitats, flora and fauna receptors.

Receptor Sensitivity	Potential Source of Impacts	Impact Intensity	Consequence	Likelihood	Impact Significance
Habitat (Priority 2 – Priority 1)	Habitat degradation	Low	Very Low to Low	Unlikely to Less Likely	Negligible to Minor
Fauna (Priority 1)	Human disturbances	Negligible to High	Very Low to High	Unlikely to Possible	Negligible to Minor
	Human-wildlife conflict	Negligible to High	Very Low to High	Unlikely to Likely	Negligible to Moderate

6.9 Recommended Mitigation Measures

In this section, mitigation measures for future developments are discussed. Mitigation measures are implemented in the following order: (1) avoidance, (2) minimisation, and (3) compensation and enhancement. Avoidance of the impact is first attempted. If avoidance is not possible, the construction impacts will be minimised. Finally, if habitat loss must occur, compensation and enhancement of remaining/nearby habitats should be adopted as a form of impact mitigation. Due to the nature of this project, mitigation measures may not be fully applicable during construction phase and habitat loss is unavoidable, but the creation of a high ecological value habitat from a low value habitat results in a net gain.

It is important to note that the successful implementation of mitigation measures requires the commitment of contractors, arborists and biodiversity specialists. Some of the major concerns around this proposed project include habitat loss and human-wildlife interactions/conflict.

6.9.1 Design Phase

The design of the Project should first be considered in the mitigation as it has the most potential to influence the extent and types of impacts that affect the sensitive biological receptors.

6.9.1.1 Minimise

Major impacts should be confined within the disused ponds—but indirect impacts through sedimentation can result in **Major to Moderate** through the decline in plant health to some plant species. Subsequently, despite incurring only **Minor** impacts in the terrestrial habitat from construction of facilities and amenities, it is still important to ensure that impacts are minimise whenever possible.

Impacts: (1) Loss of vegetation/habitat to habitat receptors, (2) loss of/reduction in habitats and food sources to faunal species receptors, (3) mortality to flora receptors and (4) decline in plant health to flora receptors

Solution: Conduct site walk before commencement of works

Site walk should identify areas for the future facilities and amenities that would avoid the need for vegetation clearance and away for conservation significant species. While site walk along the disused ponds should be conducted to assess possibility of avoiding mortality and decline in plant health to trees along the edge of the disused ponds.

Subsequently, construction methods should also be thought of as part of the design—to ensure that design propose are feasible to be conducted by small machineries/manually and construction access has minimal need for vegetation clearance.

6.9.2 Construction Phase

Major impacts incurred through habitat loss and plant mortality should be addressed through design and planning, at the design phase. At the construction phase, impact mitigation should focus on reducing **Minor** to **Moderate** impacts such as human disturbances and wildlife-human conflict to fauna receptors. Key measures to minimise these impacts are described below and should be implemented as part of the Environmental Monitoring and Management Plan (EMMP) during the construction phase.

6.9.2.1 Minimise

In addition to minimum controls in Section 6.7, Table 6-32 below provides a summary of the key recommended measures to minimise biodiversity impacts during the construction phase.

Table 6-29 Key recommended measures to minimise biodiversity impacts during the construction phase.

Receptors	Impact Types	Mitigation Measures
Habitats	<ul style="list-style-type: none"> Loss of vegetation Habitat degradation 	<ul style="list-style-type: none"> Conduct regular inspections to ensure contractor compliance to the EMMP, with oversight by NParks. Ensure silt fences and other silt control measures along the worksite hoarding are installed and maintained properly. Engage a Qualified Erosion Control Professional (QECP) to formulate and implement an Earth Control Measures (ECM) plan in accordance with PUB requirements. Implement dust control measures such as dust screens and water suppression systems. Conduct monitoring to identify any impacts to habitats adjacent to the worksite. Implement double silt screen, one at the entrance to the disused ponds and another at works boundary. Manual backfilling is recommended over the use of machineries. As much as possible, recommend filling the disused ponds during incoming tide and backfilling during receding tide should be avoided. Care should be taken to ensure the silt fences form a closed environment during outgoing tide as much as possible. The opening of the silt fence should be positioned to receive marine inflow.
Plant species	<ul style="list-style-type: none"> Mortality 	<ul style="list-style-type: none"> Ensure there are no works and disturbances to areas outside of worksite. Engage flora specialists to clearly mark out areas and plants with conservation value before the start of works. This would avoid clearing unnecessary working space, eliminate the need of removing plants of conservation significance as much as possible— <i>Lumnitzera racemosa</i>, <i>Ceriops zippeliana</i>, <i>Lumnitzera littorea</i> and <i>Ceriops tagal</i>. Engage flora specialists to assess if affected species can be harvest/transplanted before the start of works. Collect mangrove propagules and disperse within the Ponds to help with mangrove recruitment. Do not recommend filling from the bunds, instead filling should be from within the disused ponds. Conduct regular inspections to ensure contractor compliance to the EMMP.
Faunal species	<ul style="list-style-type: none"> Accidental injury or mortality Human-wildlife conflict Human disturbances 	<ul style="list-style-type: none"> It is recommended to avoid tree felling and vegetation clearance during peak bird breeding season (March to July) Pre-felling fauna inspection should be conducted before felling any trees or removing any vegetation. This should be planned and overseen by an Ecologist. Any tree found during pre-felling inspection to be harbouring an active nest should be left undisturbed until when the nest is abandoned. Bamboo clusters to be felled will be observed during dusk for bamboo bat activities, as well as during felling, so that roosting bats may be secured and released safely.

Receptors	Impact Types	Mitigation Measures
		<ul style="list-style-type: none"> Quieter construction machinery/equipment should be used over loud and noisy machinery/equipment whenever possible. Night-time works should be avoided to prevent disturbance to nocturnal fauna; recommended to restrict working hours to 0800–1800. Establish a Wildlife Response Plan in consultation with NParks Animal Management Centre and NParks Ubin Management, to be executed during encounters with trapped, injured or dead wildlife, as well as incidents of human-wildlife conflict. Conduct regular site inspections to ensure contractor compliance to EMMP and to identify potential fauna entrapments. Train site personnel on biodiversity awareness and actions to take when encountering wildlife. Ensure good housekeeping controls such as provision of wildlife-proof bins and eating areas to prevent macaques and wild boars from accessing anthropogenic food sources. Reduce use of heavy machinery during backfilling Restrict entry of site personnel to areas outside the worksite. To stagger backfilling of the disused ponds to allow fauna such as birds access to other disused ponds during construction phase.

6.9.3 Operational Phase

The most substantive impacts are **Moderate** impacts incurred through human-wildlife conflict and human disturbances were assessed to impact fauna species at the operational stage. **Negligible** to **Minor** impacts are only incurred to habitats and flora receptors at the operational phase. Key measures to minimise these impacts are described below and should be implemented as part of the post-construction monitoring during operational phase.

As mentioned, regular post-construction monitoring is recommended in the initial phase (12 months) is recommended to ensure that the proposed mitigating measures and mangrove restoration strategies are effective. Monitoring programme should include:

Biodiversity monitoring for targeted key species:

1. Mangrove monitoring: Primarily to monitor recruitment of mangrove species within the disused ponds in terms of distribution and species diversity.
2. Macrobenthos monitoring: To monitor for conservation species such as the mangrove horseshoe crab (*Carcinoscorpius rotundicauda*) and dubious nerite (*Clithon oualaniensis*) re-establishment amongst other common macrobenthos species. Additionally, take note of new conservation significant species that were not recorded during baseline.

6.10 Residual Impacts

6.10.1 Construction Phase

6.10.1.1 Habitats

During the construction phase, **Major** impact may result from loss of vegetation/habitat, affecting the soft-sediment seabed habitats within the disused ponds. Given the end goal of converting the low value soft-sediment seabed habitat to a high value mangrove habitat, there is no feasible mitigation measure that can be applied and both habitat and vegetation loss is unavoidable. However, as detailed in the discussion on habitat restoration (Section 6.8.3.2), the negative impacts of habitat and vegetation loss during construction phase will be recovered upon successful mangrove restoration.

Habitat degradation within the marine environment can be reduced by applying minimum control and mitigation measures such as implementing double silt fence and manual filling.

6.10.1.2 Flora

For the 45 plant species recorded from the Study Area and selected for the assessment of ecological impacts during the construction phase before mitigation measures were deemed to be **Moderate** for five species.

All five species will be impacted by backfilling—*Halophila ovalis* will be removed during the backfilling works resulting in 100% mortality, where impacts of such cannot be reduced as it is impractical to transplant a low biomass of seagrass to the adjacent seagrass meadow at Chek Jawa. However, as mentioned above, Chek Jawa stands to benefit from its synergistic relationship with the mangrove when restoration is completed. While the four other mangrove species, *Lumnitzera racemosa*, *Ceriops zippeliana*, *Lumnitzera littorea* and *Ceriops taga*, seedlings that were harvested should be planted back after construction works are completed or planted to other suitable areas. Special care also be taken to ensure that these species are not affected as much as possible. With such mitigation measure implemented, the intensity can be reduced to **Negligible**, resulting in reduced impact significance to **Minor**.

6.10.1.3 Fauna

A **Moderate** impact may result from accidental injury or mortality, human-wildlife conflict and human disturbances at construction phase pre-mitigation.

Accidental injury or mortality can be reduced with controlled backfilling measures. Studies have reported that mussels and oysters can cope with sediment deposition of 1 to 2 cm and recovery of benthos at dump sites can occur if interval between successive backfilling is sufficiently long [P-70]. However, even before fatal burial depth is reached, benthic animals can be affected, especially when sedimentation rate is higher than the rate at which the animals can maintain their position relative to the sediment-water interface in the newly deposited sediment [P-69]. The impact of accidental injury or mortality is unlikely to be completely mitigated due to the nature of the project and will still result in moderate impact for two horseshoe crab which are both conservation significant species (*Carcinoscorpius rotundicauda* and *Tachypleus gigas*). With successful mangrove restoration, the population of these two species is expected to rebound, given the higher ecological productivity that would result from the improvement of a soft-sediment seabed to a mangrove habitat.

Human-wildlife conflicts occur when there are negative interactions between humans and wildlife, e.g., human injury caused by wildlife. One key driver of human-wildlife conflict is access to anthropogenic food sources. Food is a major attractant for wildlife, and anthropogenic sources of food, e.g., rubbish, tend to be easily accessible, of high yields, and a reliable food source for animals. Wildlife, such as the long-tailed macaques, attracted to these food sources may encounter humans, thus increasing the likelihood of negative human-wildlife interactions. Reducing human-wildlife conflicts would require proper trash management within the development. Site personnel can be discouraged from entering the disused ponds unnecessarily during construction. These measures can be reiterated during regular toolbox briefing to help on-site workers understand sensitivity of habitat and fauna species is within the area and how to react when fauna is encountered.

In addition, human disturbances can be mitigated by staggered filling of the disused ponds to allow shorebirds and mangrove fauna species to utilise the other undisturbed disused ponds during the construction phase.

Thus, overall residual impact significance on fauna due to human-wildlife conflict and human disturbances can be reduced to **Minor**. A summary of residual impacts on fauna receptors is given in Table 6-30.

Subsequently, reducing human-wildlife conflict with wild boars (*Sus scrofa*) is also important. Although not included in the Impact Assessment due to its non-threatened status, it is recognised that human-wildlife conflict with wild boars (*Sus scrofa*) may pose an issue during construction phase due to their aggressive nature, which is of significant risk to human safety. Similar to addressing human-wildlife conflict with the long-tailed macaque (*Macaca fascicularis*), proper trash management and cutting off access to food on site is key to preventing conflict, especially since they were frequently sighted on surveys and in our camera traps.

Table 6-30 Summary of construction phase residual impacts to faunal receptors.

Impact Type	No. of Species			
	Major	Moderate	Minor	Negligible
Accidental injury or mortality	-	2	59	102

Impact Type	No. of Species			
	Major	Moderate	Minor	Negligible
Human-wildlife conflict	-	-	10	153
Loss of/reduction of ecological connectivity for faunal movement	-	-	-	163
Human disturbances	-	-	28	135

6.10.1.4 Overview

As discussed in the sections above, the evaluation of construction impacts on habitats, flora and fauna are summarised in the Table 6-31.

Table 6-31 Summary of impact evaluation on habitats, flora and fauna receptors

Receptor Sensitivity	Potential Source of Impacts	Impact Intensity	Consequence	Likelihood	Impact Significance
Habitat (Priority 2 – Priority 1)	Loss of vegetation	Negligible to High	Imperceptible to Medium	Unlikely to Certain	Negligible to Major
	Habitat degradation	Low to High	Very Low to Medium	Unlikely to Likely	Negligible to Minor
Flora (Priority 2 – Priority 1)	Mortality	Negligible to Low	Very Low to Low	Unlikely to Certain	Negligible to Moderate
	Decline in plant health	Negligible to Low	Very Low to Low	Unlikely	Negligible
Fauna (Priority 1)	Loss/reduction of ecological connectivity for faunal movement	Negligible to High	Very Low to High	Unlikely	Negligible
	Accidental injury or mortality	Low to High	Very Low to High	Unlikely to Less Likely	Negligible to Minor
	Human disturbances	Negligible to High	Very Low to High	Unlikely	Negligible to Minor
	Human-wildlife conflict	Negligible to High	Very Low to High	Unlikely to Less Likely	Negligible to Minor

6.10.2 Operational Phase

6.10.2.1 Habitat

None of the habitat receptors were deemed to have **Major** or **Moderate** impacts during the operational phase.

6.10.2.2 Flora

Not applicable as there are no operational impacts for flora receptors at the operational phase, see Section 6.5.

6.10.2.3 Fauna

Human-wildlife conflict will result in **Minor** to **Moderate** impact to faunal receptors during the operational phase. This is especially so with animals that can be perceived as a threat, such as macaques (*Macaca fascicularis*) and terrestrial snake species. Other instances where fauna may be subjected to human-wildlife conflict is with slow moving fauna that are frequently handled by humans. These includes the horseshoe crabs (Xiphosphurid) and Malayan box terrapin (*Cuora ambionensis*).

Human-wildlife conflict can be reduced by educating the public. Informative signboard should be put up around the area with anticipated increase in human traffic i.e. around the new pavilion to educate the public on managing wildlife encounters to reduce human-wildlife conflict between humans and long-tailed macaques in the area; a no-feeding sign should be put up. Similarly for non-marine snakes, signboards could be a tool for the public to gain

insight into their ecology and aid in guiding them to act appropriately when around snakes, especially venomous ones, so that neither humans or wildlife gets injured during an encounter. Residual impact is now **Minor** to **Negligible**.

There are no mitigation measures for Human disturbances at site during operational phase since the area is largely closed off to public and impact significance is **Negligible** to **Low**.

Other noteworthy issues at the operational phase include:

1. Although the Malayan nawab is not expected to be impacted during operational phase, care should be taken to avoid unnecessarily removing too much of the Malayan nawab (*Polyura moori moori*) host plant, *Melastoma malabathricum* during site maintenance. This will ensure that the Malayan nawab will continue to thrive.
2. Although not included in the Impact Assessment due to its non-threatened status, it is recognised that human-wildlife conflict with wild boars (*Sus scrofa*) may pose an issue during operational phase due to their aggressive nature, which is of significant risk to human safety. Signboards should be placed around the site, especially the pavilion, to inform the public to be vigilant when in the area. It should also inform them of the risks of leaving food unattended, which may attract wild boars and as a result increase their encounter rate.

A summary of residual impacts to fauna receptors is given in Table 6-32.

Table 6-32 Summary of operational phase residual impacts to faunal receptors.

Impact Type	No. of Species			
	Major	Moderate	Minor	Negligible
Human-wildlife conflict	-	-	9	154
Human disturbances	-	-	41	122

6.10.2.4 Overview

As discussed in the sections above, the evaluation of construction impacts on habitats, flora and fauna are summarised in Table 6-33.

Table 6-33 Summary of impact evaluation on habitats, flora and fauna receptors.

Receptor Sensitivity	Potential Source of Impacts	Impact Intensity	Consequence	Likelihood	Impact Significance
Habitat (Priority 2 – Priority 1)	Habitat degradation	Low	Very Low to Low	Unlikely to Less Likely	Negligible to Minor
Fauna (Priority 1)	Human disturbances	Negligible to Low	Very Low to Medium	Unlikely to Less Likely	Negligible to Minor
	Human-wildlife conflict	Negligible to Low	Very Low to Medium	Unlikely	Negligible to Minor

6.11 Cumulative Impacts from Other Major Concurrent Projects

Major concurrent development considers all project mention in Section 3.10 (i.e. all construction projects within 2-km distance).

One concurrent terrestrial project in the vicinity has been identified to be within 2-km radius of Study Area—the enhancement of fire safety infrastructure for Pulau Ubin (in the main village). Works is expected to be of a small

and localise footprint which will result in Negligible cumulative impact to Sungei Durian. Furthermore, overlapping timeline would only be for 5 months, short considering the duration of this Sungei Durian Project.

For works within the Marine Area, impacts considered are largely indirect impacts such as the spread of sedimentation, resulting in increased turbidity, water quality changes and changes in morphology. Therefore, since cumulative impacts for assessed for Marine Water in Section 6.11 is Negligible to Minor. Cumulative impacts for biodiversity would also be Negligible to Minor.

6.12 Summary of Key Findings

Sungei Durian consists of five major habitat types including abandoned-land forest, mangrove forest, scrubland and herbaceous vegetation, soft-sediment seabed and marine area which also harbour a small patch of spoon seagrass (*Halophila ovalis*). 195 flora, 78 marine and 128 terrestrial fauna species were recorded within Sungei Durian, with a total of 55 conservation significant plant species and 19 conservation significant fauna species (including terrestrial and aquatic). Camera trap data reveals the presence of two separate Critically Endangered leopard cat (*Prionailurus bengalensis*) individuals utilising the scrubland and herbaceous vegetation habitats atop the bunds, which are not expected to be affected by the planned works. While mitigation measures can be put in place to reduce much of the impact from construction phase, degradation of mangrove plants surrounding the ponds and of the mortality of spoon seagrass patch as well as aquatic fauna within the soft-sediment seabed cannot be mitigated, although efforts can be made to reduce the impact intensity to mangrove plants and mangrove dwelling fauna. Such measures include staggered backfilling of the ponds, restricted access routes into ponds to reduce vegetation damage and reducing the use of heavy machineries as much as possible. The mangroves are expected to recover more biomass and biodiversity than the current soft-sediment seabed habitat during its operational phase given its high recruitment potential, negating any of the negative impacts from construction phase. The successfully restored mangrove will be diverse in both fauna and flora community, benefit adjacent coastal habitats via synergistic effects, as well as aid in reducing sedimentation in surrounding waters.

7 Marine Water

7.1 Introduction

This section includes the assessment of hydrodynamics, water quality (including sediment plume), morphology, and underwater noise within the Project Site and its vicinity, as well as the evaluation of the impacts arising from the Project's construction and operational phases on the marine waters in the vicinity of the Project Site. Results from the site surveys were presented to establish the baseline conditions, and were subsequently used to analyse the changes that might occur due to impacts associated with the construction and operational activities of the Project. Sensitive receptors were identified and classified according to the sensitivity categorization defined in Section 7.5. The prediction of impacts was conducted by considering the various potential sources of impact from the Project which could affect the identified sensitive receptors. Minimum control measures, which are standard practices that should be implemented on-site during the construction and operational phase, were also described and considered during impact prediction. Thereafter, an impact evaluation was carried out to assess the significance of the predicted impacts, and mitigation measures were proposed when necessary. An EMMP was also developed to specify methods and measures to be implemented during construction and operation of the Project which are necessary to reduce environmental impacts to minimal levels (see Section 13).

The scope of work of the marine water impact assessment is consisted of:

- Reviewing data provided by the Client to understand the topographic characteristics of the Project Site and its vicinity;
- Site reconnaissance survey for a better understanding of the topography, bathymetry, hydrology, hydrodynamics, land cover, and existing waterbodies with their properties (i.e. locations, water flow conditions and bank characteristics) within the Project Site and its vicinity;
- Identification of sampling locations, sampling for in-situ and ex-situ water quality analysis as well as sediment quality sampling and analysis of existing waterbodies located within the Project Site and its vicinity;
- Hydrodynamic, water quality (including sediment plume), morphology, and underwater noise impact analysis to assess the potential impacts of the Project during construction and operational phases; and
- Propose EMMP to mitigate potential impacts of the Project during construction and operational phases.

7.2 Methodology and Assumptions

7.2.1 Marine Water and Sediment Baseline Surveys

The waterbodies within the Project Site and its vicinity were studied through a combination of site survey, visual, in-situ and ex-situ water sampling, sediment sampling and laboratory testing. The baseline water quality, sediment quality, and waterbody characteristics were assessed. Sediment samples were collected from the identified waterbodies within the Project Site and its vicinity and its quality was assessed by ex-situ laboratory testing. These details formed the baseline data which can be referred to, and compared against, when monitoring results are available at the time of construction/ operational stage to establish the extent of environmental impacts from these stages associated with the proposed development.

7.2.1.1 Desktop Research

Desktop research consists of a review of secondary data (including existing topographic data, vegetation cover, existing land use and activities, satellite images, etc.) which aided in understanding the conditions of the waterbodies within the Project Site. The information retrieved during the desktop research comprised of publicly available data from government and technical agencies, existing available data (e.g. rainfall data, online satellite images), as well as published books, relevant articles, and other online sources.

Additional secondary data reviewed includes sediment quality data of sediment sampled from the concurrent Northern Pulau Ubin project site (refer to Section 3.6.2.2 for a detailed description of the sediment source), where the proposed fill material will be sourced for this project. The sediment quality data was analysed and assessed to

determine the level of contaminants present and on whether the proposed fill material would pose environmental hazards should it be utilised for the filling works in this Project.

7.2.1.2 Field Surveys

The activities performed as part of the field assessment included the following:

- Evaluate the accessibility of the waterbodies through site reconnaissance or using topographic survey data;
- Verify the information collected from the available topographic survey as well as satellite images; and
- Assess current water quality conditions in existing waterbodies within the Project Site and its vicinity.

7.2.1.2.1 Hydrological Survey

The hydrological survey was conducted to identify and outline existing waterbodies within the Project Site and its vicinity. A GPS device was used to track the hydrological survey route. The GPS data then synchronised with the photos taken on-site to identify the exact location of identified waterbodies.

Using the available topographic survey data, ArcGIS was used to develop elevation and slope maps for the site to support the hydrological survey. Catchment delineation was carried out for catchment analysis, through which the water sources contributing to the waterbodies and how the water flows within the Project Site and its vicinity could be identified.

The known waterbodies within the Project Site and its vicinity have been identified and presented in Figure 7-2.

7.2.1.2.2 Hydrodynamic Survey

An Acoustic Doppler Current Profiler (ADCP) will be deployed at an offshore location in the vicinity of the Project Site for a period of one month for oceanographic data collection. The measured baseline hydrodynamic conditions (e.g. tide level, current regime including current speed and direction) were used for model calibration. The proposed location for the deployment of ADCP (Latitude: 1°23'58.33"N, Longitude: 103°58'26.39"E) is indicated in Figure 7-1.



Legend

-  Location of ADCP
-  Sungei Durian Ponds Project Site



Rev.	Date	By	Description	Chk'd	App'd
-	AUG 2022	CQA	EIA Report	NHT	JAG

Qualified Person Endorsement :
NA

NParks Endorsement : NA

Consultant : **AECOM**

Project Title :
**CONTRACT NPARKS/N/39/2017
CONSULTANCY SERVICES FOR SHORELINE
WORKS IN PULAU UBIN
(MANGROVE RESTORATION OF
SUNGEI DURIAN PONDS)**

Designed CQA	Checked NHT	Approved JAG
Drawn CQA	Date AUG 2022	

Client: 

Figure Title :
Location of ADCP

Figure No. : 7-1	Rev. : -	Sheet : 1 of 1
---------------------	-------------	-------------------

CAD File Name : NA

A3

7.2.1.2.3 Water Quality Survey

The baseline water quality conditions in the ponds and the surrounding marine waters were assessed. The baseline water quality results were compared with national and/or international water quality standards/criteria relevant to ecological uses. Six (6) water quality sampling locations (refer to Figure 7-2) were identified based on site reconnaissance as well as from the feedback from technical agencies. The rationale behind each water quality sampling location and site photos are presented in Table 7-1.

Generally, the main purpose of a baseline study is to obtain comprehensive water quality baseline data that captures the possible changes in the physicochemical composition of marine water during different tidal conditions in the existing marine environment. Water samples were taken during the spring and neap tides of the tidal cycle, and during each tidal condition, both flood and ebb tides were sampled. A total of twenty-four (24) samples were collected for this Project. For this Study, in-situ water quality parameters were measured using a calibrated multi-parameter digital sensor (YSI ProDSS) with USEPA approved testing methods for water quality parameters and included:

- Temperature;
- pH;
- Salinity/Conductivity;
- Turbidity;
- Dissolved oxygen (DO); and
- Total Dissolved Solids (TDS).

The ex-situ parameters were analysed by Marchwood Laboratory Services Pte Ltd (MLS) and are listed below:

- Total Suspended Solids (TSS);
- Total Nitrogen (TN);
- Ammoniacal Nitrogen (NH₄-N);
- Nitrates (NO₃-N);
- Nitrite (NO₂-N);
- Total Phosphorus (TP);
- Orthophosphate (PO₄-P);
- Heavy metals (As, Ni, Zn, Hg, Cd, Cr [VI], Cu and Pb);
- Tributyltin;
- Cyanide;
- Chlorine;
- Total Phenol;
- Biochemical Oxygen Demand (BOD₅);
- Oil and grease (Total);
- Faecal coliform; and
- *Enterococcus*.

Table 7-1 Rationale for the selected water quality sampling locations with photos.

S/N	Monitoring Location	Justification	Photo of Monitoring Location
WQ1A	Downstream of back mangrove area	To capture the water quality of the downstream of back mangrove area to support ecological findings and water quality impact assessment. This location was sampled during Neap-Ebb, Spring-Ebb, Spring-Flood conditions, as WQ1B had water levels that were too low for sampling.	

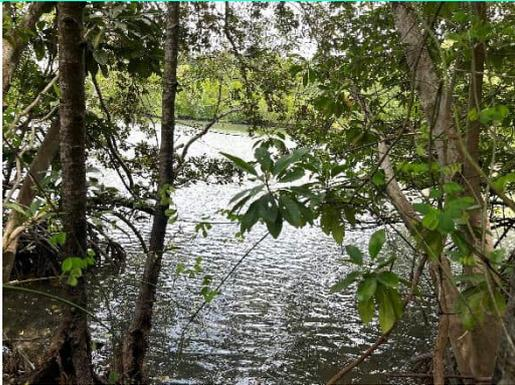
S/N	Monitoring Location	Justification	Photo of Monitoring Location
WQ1B	Upstream of back mangrove area	To capture the water quality of the upstream of back mangrove area to support ecological findings and water quality impact assessment. Samples were collected at this location during Neap-Flood condition, as this sampling point had higher water levels then that were suitable for sampling.	
WQ2	Pond 1	To capture the water quality of Pond 1 to support ecological findings and water quality impact assessment.	
WQ3	Pond 2	To capture the water quality of Pond 2 to support ecological findings and water quality impact assessment.	
WQ4	Pond 3	To capture the water quality of Pond 3 to support ecological findings and water quality impact assessment.	

S/N	Monitoring Location	Justification	Photo of Monitoring Location
WQ5	Coastal area outside of the Ponds	To capture the water quality in coastal water to support ecological findings and water quality impact assessment.	
WQ6	Vicinity of aquaculture farms	To capture the water quality in the vicinity of the aquaculture farms to support impact assessment of these farms.	

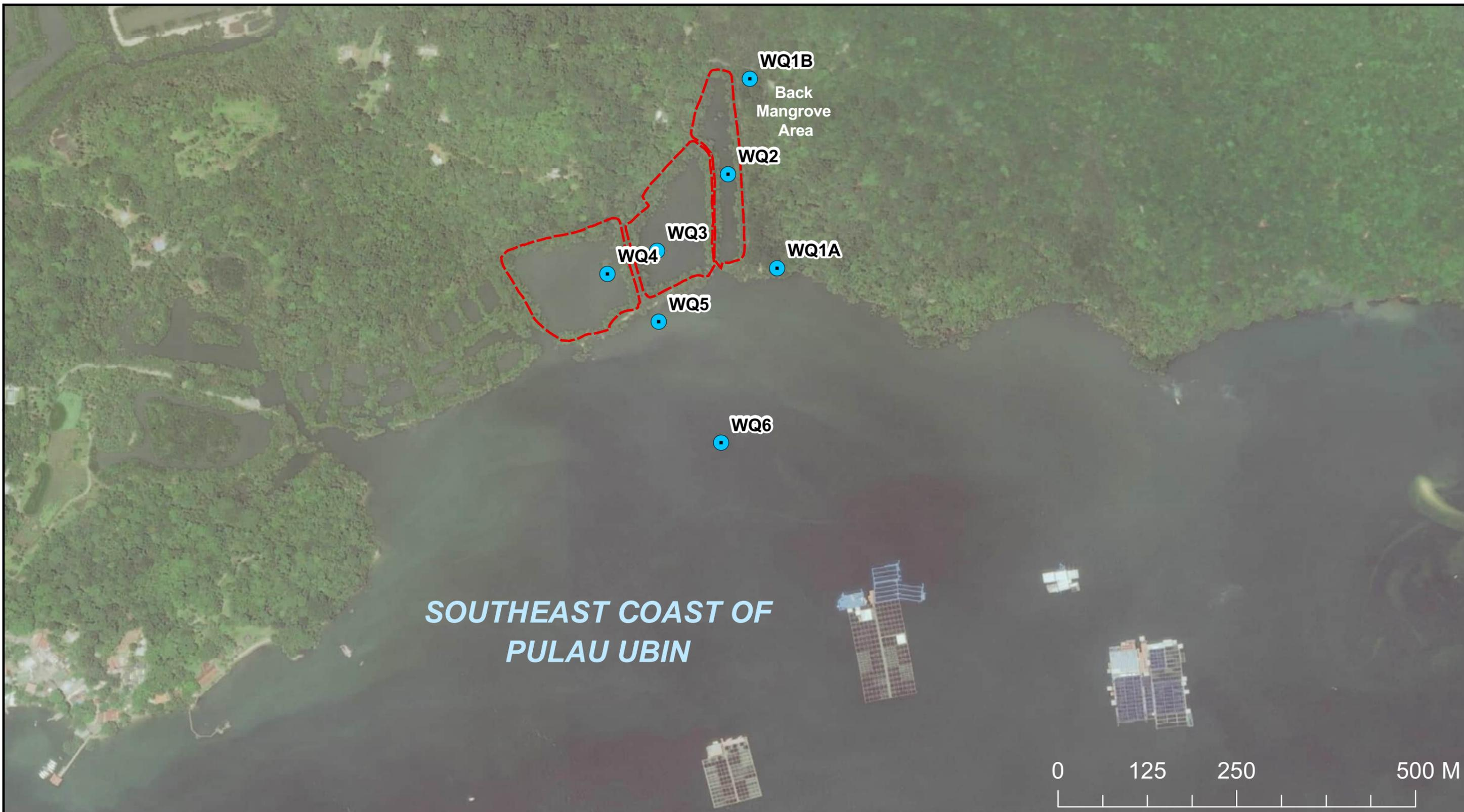

Legend

- Water Quality Sampling Locations
- Sungei Durian Ponds Project Site

N

Rev.	Date	By	Description	Chk'd	App'd
-	AUG 2022	CQA	EIA Report	NHT	JAG

Qualified Person Endorsement :
NA

NParks Endorsement : NA

Consultant : **AECOM**

Project Title :
**CONTRACT NPARKS/N/39/2017
CONSULTANCY SERVICES FOR SHORELINE
WORKS IN PULAU UBIN
(MANGROVE RESTORATION OF
SUNGEI DURIAN PONDS)**

Designed CQA	Checked NHT	Approved JAG
Drawn CQA	Date AUG 2022	

Client:

Figure Title :
Location of water quality sampling points

Figure No. : 7-2	Rev. : -	Sheet : 1 of 1
CAD File Name : NA		A3

7.2.1.2.4 Sediment Quality Survey

Baseline sediment quality survey aims to assess the baseline sediment quality as the existing pollutants accumulated in the sediments (if any) may be resuspended and released to the marine environment during the construction works, and also serves to provide particulate size distribution data for morphological and sediment plume modelling. For this baseline study, sediment samples were taken from the surface of the mudflats with a shovel from eight (8) sampling locations as shown in Figure 7-3. The rationale for the selection of each sediment sampling location is detailed in Table 7-2. The following ex-situ parameters were tested by Marchwood Laboratory Services Pte Ltd (MLS) using American Public Health Association (APHA) and United States Environmental Protection Agency (USEPA) standard methods:

- Particle size grading
- Total Nitrogen (TN);
- Total Phosphorus (TP);
- Heavy metals (As, Cd, Cr, Cu, Pb, Hg, Ni and Zn); and
- Oil and Grease (Total).

Table 7-2 Rationale for the selected sediment quality sampling locations.

S/N	Monitoring Location	Justification
S1	Back mangrove area	To capture the sediment quality of similar established mangrove sites.
S2	North-eastern corner of Pond 1	To capture the sediment quality of the mudflats in Pond 1 and to support sediment plume modelling.
S3	Middle of Pond 1	To capture the sediment quality of the mudflats in Pond 1 and to support sediment plume modelling.
S4	North-western corner of Pond 2	To capture the sediment quality of the mudflats in Pond 2 and to support sediment plume modelling.
S5	Middle of Pond 2	To capture the sediment quality of the mudflats in Pond 2 and to support sediment plume modelling.
S6	Middle of Pond 3	To capture the sediment quality of the mudflats in Pond 3 and to support sediment plume modelling.
S7	North-western corner of Pond 3	To capture the sediment quality of the mudflats in Pond 3 and to support sediment plume modelling.
S8	Coastal area outside of the Ponds	To capture the sediment quality of the coastal area and to support sediment plume modelling.

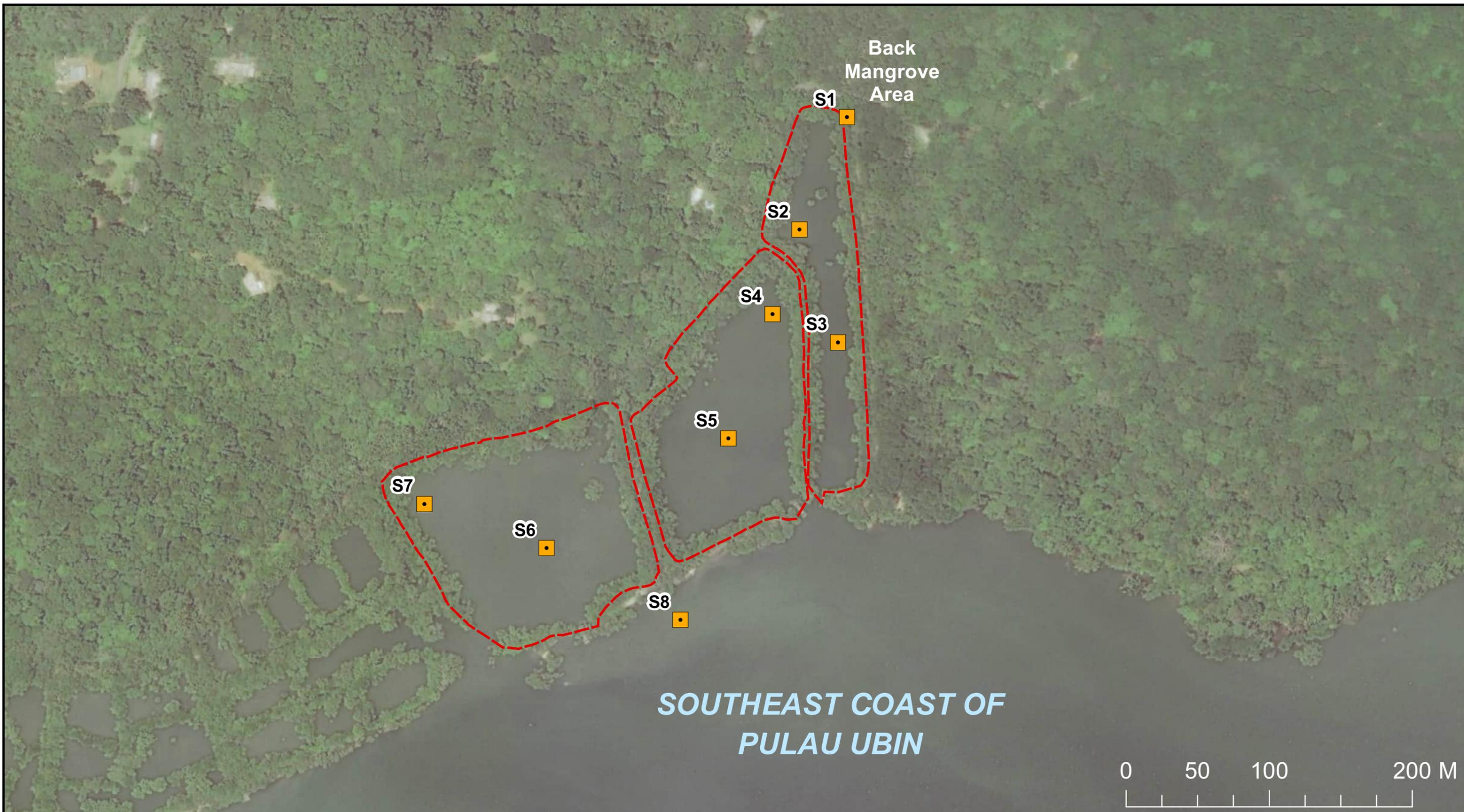

Legend

- Sediment Quality Sampling Locations
- Sungei Durian Ponds Project Site

Rev.	Date	By	Description	Chk'd	App'd
-	AUG 2022	CQA	EIA Report	NHT	JAG

Qualified Person Endorsement :
NA

NParks Endorsement : NA

Consultant : **AECOM**

Project Title :
**CONTRACT NPARKS/N/39/2017
CONSULTANCY SERVICES FOR SHORELINE
WORKS IN PULAU UBIN
(MANGROVE RESTORATION OF
SUNGEI DURIAN PONDS)**

Designed CQA	Checked NHT	Approved JAG
Drawn CQA	Date AUG 2022	

Client:

Figure Title :
Location of sediment quality sampling points

Figure No. : 7-3	Rev. : -	Sheet : 1 of 1
CAD File Name : NA		A3

7.2.2 Underwater Noise

Baseline underwater noise monitoring was conducted to establish the existing underwater noise levels in the vicinity of the Project Site. Underwater noise sensitive receptors (UNSRs) within the vicinity of the Project were hence considered before proposing the baseline monitoring location.

7.2.2.1 Desktop Research

Desktop research consisted of a review of secondary data (including existing land use and ongoing development activities, satellite images, etc.) which aided in determining the baseline underwater noise monitoring location. The information retrieved during the desktop research comprised of publicly available data from government and technical agencies, existing available data, relevant articles, and other online sources.

7.2.2.2 Field Survey

Baseline underwater noise monitoring was conducted at one (1) offshore location to establish the existing underwater noise levels in the vicinity of the Project Site. This monitoring location was selected based on the identified Underwater Noise Sensitive Receptors, such as fauna and habitats of high ecological value as well as fishes in the nearby aquaculture farms.

Unattended underwater noise monitoring was conducted for two separate two-day monitoring events to capture the baseline ambient noise levels along the Serangoon Harbour. The Porpoise Acoustic Recorder hydrophone and datalogger were deployed at an offshore location in the vicinity of the Project Site (refer to Table 7-3 and Figure 7-4). The location was also selected due to its suitable water depth and current conditions for underwater noise monitoring. Detailed survey report can be found in Appendix S.

Table 7-3 Rationale for the selected underwater noise monitoring location.

S/N	Monitoring Location	Justification
N1	Offshore location along Serangoon Harbour, near the aquaculture farms	Aquaculture farms located south of the Project Site and the marine environment of Serangoon Harbour are ecologically sensitive areas that are in the vicinity of the Project Site. The selected location represents the acoustic environment of the ecologically sensitive area in the vicinity of the Project Site.



Legend

- Underwater Noise Monitoring Location
- Sungei Durian Ponds Project Site

N
↑

Rev.	Date	By	Description	Chk'd	App'd
06	FEB 2023	CQA	EIA Report	NHT	JAG

Qualified Person Endorsement :
NA

NParks Endorsement : NA

Consultant : **AECOM**

Project Title :
**CONTRACT NPARKS/N/39/2017
CONSULTANCY SERVICES FOR SHORELINE
WORKS IN PULAU UBIN
(MANGROVE RESTORATION OF
SUNGEI DURIAN PONDS)**

Designed CQA	Checked NHT	Approved JAG
Drawn CQA	Date FEB 2023	

Client:

Figure Title :
Location of underwater noise monitoring point

Figure No. : 7-4	Rev. 06	Sheet 1 of 1
CAD File Name : NA		A3

7.2.3 Baseline Data Analysis and Assessment

7.2.3.1 Hydrology Baseline Assessment

The elevation and slope maps of the Project Site and its vicinity were developed based on surveyed topographic survey data using GIS technique. In order to determine the exact locations of each of the identified waterbodies, GPS data from surveys was synchronised with the photos taken on site. Catchment analysis was conducted based on surveyed topographic data as well as the developed elevation and slope maps. Catchment delineation is key in identifying the main sources of water that feed each of the waterbodies within the Project Site and its vicinity and to provide an understanding of how the runoff flows within the site.

7.2.3.2 Hydrodynamic Baseline Assessment

The hydrodynamic conditions (i.e. tide level, current regime including current speed and direction) will be extracted from the ADCP measurement as mentioned in Section 7.2.1.2.2. The tide level, in terms of water depth, will be analysed for at least one full tidal cycle against a time-series. In addition, the maximum tide range will be generated. For current regime, the current directions and maximum current speeds will be calculated for spring and neap tides for both flood and ebb tides. Both measured tide levels and current regime will be further utilised for hydrodynamic model calibration.

7.2.3.3 Water Quality Baseline Assessment

The baseline water quality of the waterbodies located within the Project Site and its vicinity was determined by comparing the selected parameters against the NEA Trade Effluent Discharge Limits for uncontrolled waterbodies [R-20] and Singapore NEA Water Quality Guidelines for Recreational Beaches [W-24]. This comparison could be used to determine whether the existing baseline water quality of the waterbodies within the Project Site and its vicinity complies with NEA limits or already exceeds these limits. However, the NEA Trade Effluent Discharge limits does not provide targeted criteria for the preservation and growth of aquatic life. To assess the water quality for beneficial uses such as recreational activities, habitats of seagrass and mangroves in the coastal waters, the baseline water quality was compared to ASEAN Marine Water Quality Management Guidelines [R-22]. This ambient water quality criteria provide a benchmark for evaluation of marine environments for aquatic life protection and human health protection. To assess whether the surface water quality within the Project Site and its vicinity is suitable for aquatic life, selected parameters were compared to water quality criteria for aquatic life from other countries such as USEPA [R-18]. The relevant limits and guidelines for water quality parameters were summarised in Table 7-4; however, for parameters without recommended limits, the monitored results would be considered as the minimum criteria to be met during construction and operational phase.

Table 7-4 Water quality guidelines and criteria

Parameter	NEA Trade Effluent Discharge Limits ¹	ASEAN Marine Water Quality Criteria ²	Criteria for Aquatic life ³
pH	6 - 9	-	6.5 – 8.5 (USEPA)
Temperature (°C)	≤ 45	≤ 2°C above the maximum ambient temperature	-
Salinity (PSU)	-	-	-
Conductivity (µS/cm)	-	-	-
Total Dissolved Solids, TDS (mg/L)	-	-	-
Dissolved Oxygen, DO (mg/L)	-	≥ 4.0	-
Turbidity (NTU)	-	-	-
Total Suspended Solids, TSS (mg/L)	50	≤ 10% increase over seasonal average	-
Tributyltin (ng/L)	-	10	-
Total Phosphorous, TP (mg/L)	-	-	Inshore: 0.015 (AGI, 2000) Offshore: 0.010 (AGI, 2000)
Orthophosphate as PO ₄ -P (mg/L)	≤ 1.625 (equivalent to 5 as PO ₄)	Coastal water: ≤ 0.015 (equivalent to 0.045 as PO ₄)	-

Parameter	NEA Trade Effluent Discharge Limits ¹	ASEAN Marine Water Quality Criteria ²	Criteria for Aquatic life ³
Total Nitrogen, TN (mg/L)	-	-	0.1 (AGI, 2000)
Ammonium as NH ₄ -N (mg/L)	-	0.07	-
Nitrite as NO ₂ -N (mg/L)	-	0.055	-
Nitrate as NO ₃ -N (mg/L)	-	0.06	-
Biochemical Oxygen Demand, BOD ₅ (mg/L)	20	-	4 (USEPA)
Total Phenol (mg/L)	-	0.12	-
Free Chlorine (µg/L)	-	-	-
Cyanide, CN ⁻ (mg/L)	-	0.007	-
<i>Enterococcus</i> , (CFU/100ml)	200 ⁴	35	-
Faecal coliform, (CFU/100ml)	-	100	-
Lead, Pb (µg/L)	100	8.5	-
Arsenic, As (µg/L)	-	120	-
Cadmium (µg/L)	-	10	-
Chromium (VI), (µg/L)	-	50	-
Copper, Cu (µg/L)	-	8	-
Nickel, Ni (µg/L)	-	-	Chronic: 8.2 (USEPA) Acute: 74 (USEPA)
Zinc, Zn (µg/L)	-	-	Chronic: 81 (USEPA) Acute: 90 (USEPA)
Mercury, Hg (µg/L)	-	0.16	-
Oil and Grease (Total) (mg/L)	-	0.14	-
Note:			
(1). NEA Trade Effluent Discharge Limits for discharge into an uncontrolled watercourse.			
(2). ASEAN Marine Water Quality Criteria – for aquatic life protection and for human health protection.			
(3). The sources of international water quality criteria for aquatic life include USEPA [R-18].			
(4). Singapore's Water Quality Guidelines for Recreational Beaches [W-24] requires that the <i>Enterococcus</i> count should be less than or equal to 200 counts per 100 millilitres of water at 95% of the time for safe recreational use by the public.			

7.2.3.4 Sediment Quality Baseline Assessment

The baseline sediment quality of the waterbodies located within the Project Site and its vicinity was determined by comparing the selected parameters against the Singapore MPA's General Guidelines on the Requirements for Application on Dredging and Dumping Works. Where the MPA guidelines does not have the necessary limits for comparison, reference has been made to other environmental standards published overseas for guidance, which are summarised in the Table 7-5 below. These sediment quality guidelines include Sediment Quality Assessment Guidelines for Florida Coastal Waters and Ontario Guidelines for the Protection and Management of Aquatic Sediment Quality, which considers the recommended limits for environmental protection and assesses the impact on marine flora and fauna from the full range of natural processes governing the fate and transport of contaminants from the sediment.

Furthermore, the particle size of the sediments at the sampling locations in the Project Site and its vicinity was used as input for morphological and sediment plume modelling works.

Table 7-5 Guideline values (in mg/kg) for sediment quality.

Test Parameters (mg/kg)	Singapore General Guidelines for Dredging/ Dumping Works (XXX)	Sediment Quality Assessment Guidelines for Florida Coastal Waters (FDEP, 1994)		Ontario Guidelines for the Protection and Management of Aquatic Sediment Quality (MEE, 1993)	
		TEL ¹	PEL ²	LEL ³	SEL ⁴
Arsenic	30	7.24	41.6	6	33
Cadmium	1	0.676	4.21	0.6	10
Chromium	50	52.3	160	26	110
Copper	55	18.7	108	16	110
Nickel	35	15.9	42.8	16	75
Lead	65	30.2	112	31	250
Zinc	150	124	271	120	820
Mercury	0.8	0.13	0.696	0.2	2
Total Phosphorus	N.A.	N.A.	N.A.	600	2000
Total Nitrogen	N.A.	N.A.	N.A.	550	4800
Oil & Grease	N.A.	N.A.	N.A.	1500 ⁵	

Notes:

1. TEL – Threshold Effects Level, represents the concentration below which adverse biological effects are expected to occur rarely.
2. PEL – Probable Effects Level, defines the level above which adverse effects are expected to occur frequently.
3. LEL – Low Effects Level
4. SEL – Severe Effects Level
5. Only open water disposal guidelines for Oil & Grease is available.
6. N.A. – Not Available

7.2.3.5 Underwater Noise Baseline Data Analysis and Assessment

The underwater noise baseline data was processed using PAMGuide in MATLAB and was analysed to identify the percentile spectral levels of ambient underwater soundscape for the monitored period. The baseline underwater noise levels were analysed with respect to the known hearing sensitivity ranges of auditory sensitive fauna, such as fish and marine mammals, with reference to technical guides from Acoustic Society of America (ANSI) [R-31], European Commission [R-28], US National Oceanic and Atmospheric Administration (NOAA) [R-27] and other research papers.

Due to the lack of available international and local guidelines for underwater noise, Table 7-6, Table 7-7 and Table 7-8 summarised a few recommended underwater noise criteria for marine mammals and fishes from previous studies [R-31,P-82]. Generally, the source of underwater noise could come from pulse or continuous noise sources. For example, vessel traffic is classified as a continuous noise source while noise generated by certain construction activities such as piling is considered a single or multiple pulse noise source. It is expected that continuous underwater noise sources (i.e. vessel traffic) dominate the East Johor Strait ambient soundscape as there is currently no major underwater construction activities in the vicinity. In addition, during the construction phase of this Project, the underwater noise source is also expected to be limited to engine noise (as continuous noise source) generated by the tugboat towing the fill material to the Project Site (refer to Section 3.7 for the proposed construction activities taking place during construction phase).

Therefore, the underwater noise discussion in this report will mainly focus on continuous noise sources referring to Table 7-6 and Table 7-8.

Table 7-6 Recommended underwater noise criteria for marine mammal from literature review [P-82].

Type of Sound / Criteria Metric	Effect	Marine Mammal Hearing Group	
		All Cetaceans	Pinnipeds
Single Pulses			
Peak pressure level (dB re 1 µPa)	Potential strong behavioural reaction	224	212
Sound Exposure Level ¹ (dB re 1 µPa ² s)		183	171
Multiple Pulses			
Root mean square (RMS) sound pressure level (dB re 1 µPa)	Potential strong behavioural reaction	160	
	Low level marine mammal disturbance	140	
Continuous Sound			
Root mean square (RMS) sound pressure level (dB re 1 µPa)	Potential strong behavioural reaction	120	
Note:			
¹ Sound exposure level (SEL) refers to the measure of the total sound energy of an event or a number of events and is normalised to one second.			
² Root mean square (RMS) sound pressure level used as a description of the average amplitude of the variations in pressure over a specific time window.			

Table 7-7 Recommended underwater noise criteria for fish due to impulsive sound from literature review [R-31].

Type of Animal	Parameter	Mortality and Potential Mortal Injury	Impairment	
			Recoverable Injury	Temporary Threshold Shift ¹
Impulsive Sound				
Fish: no swim bladder (particle motion detection)	SEL ³ , dB re 1 µPa ² s	>219	>216	>>219
	Peak, dB re 1 µPa	>213	>213	-
Fish: where swim bladder is not involved in hearing (particle motion detection)	SEL, dB re 1 µPa ² s	210	203	>186
	Peak, dB re 1 µPa	>207	>207	-
Fish: where swim bladder is involved in hearing (primarily pressure detection)	SEL, dB re 1 µPa ² s	207	203	186
	Peak, dB re 1 µPa	>207	>207	-
Eggs and larvae	SEL, dB re 1 µPa ² s	>210	(Near) Moderate ²	(Near) Moderate
	Peak, dB re 1 µPa	>207	(Intermediate) Low (Far) Low	(Intermediate) Low (Far) Low
Note:				
¹ Temporary threshold shift (TTS) is a temporary reduction in hearing sensitivity caused by exposure to intense sound.				

Type of Animal	Parameter	Mortality and Potential Mortal Injury			Impairment	
		Recoverable Injury		Temporary Threshold Shift ¹		
² Risk is categorised in relative terms such as “high”, “moderate” or “low” at three distances from the source: “near” (i.e. in the tens of meters), intermediate” (i.e. in the hundreds of meters), or “far” *i.e. in the thousands of meters). ³ Sound exposure level (SEL) refers to the measure of the total sound energy of an event or a number of events and is normalised to one second.						

Table 7-8 Recommended underwater noise criteria for fish due to continuous sound from literature review [R-31].

Type of Animal	Mortality and Potential Mortal Injury		Impairment	
	Recoverable Injury		Temporary Threshold Shift ¹	
Fish: no swim bladder (particle motion detection)	(Near) Low ² (Intermediate) Low (Far) Low	(Near) Low (Intermediate) Low (Far) Low	(Near) Moderate (Intermediate) Low (Far) Low	
Fish: where swim bladder is not involved in hearing (particle motion detection)	(Near) Low (Intermediate) Low (Far) Low	(Near) Low (Intermediate) Low (Far) Low	(Near) Moderate (Intermediate) Low (Far) Low	
Fish: where swim bladder is involved in hearing (primarily pressure detection)	(Near) Low (Intermediate) Low (Far) Low	170 dB re 1 µPa (rms) for 48 hours	158 dB re 1 µPa (rms) for 12 hours	
Eggs and larvae	(Near) Low (Intermediate) Low (Far) Low	(Near) Low (Intermediate) Low (Far) Low	(Near) Low (Intermediate) Low (Far) Low	
Note:				
¹ Temporary threshold shift (TTS) is a temporary reduction in hearing sensitivity caused by exposure to intense sound.				
² Risk is categorised in relative terms such as “high”, “moderate” or “low” at three distances from the source: “near” (i.e. in the tens of meters), intermediate” (i.e. in the hundreds of meters), or “far” *i.e. in the thousands of meters).				

7.2.4 Methodology for Marine Water Impact Assessment

AECOM conducted an impact assessment of the key potential environmental impacts that could arise from the proposed construction and operational works and activities, which includes the prediction and evaluation of both positive and negative impacts. The detailed methodology for the prediction and evaluation of Project impacts on marine water during construction and operational phases are described in the following sections.

7.2.4.1 Construction Phase

7.2.4.1.1 Marine Water Quality Impact Assessment

The potential impacts from Project on water quality (excluding sediment plume impacts) were assessed through qualitative approach based on primary and secondary data, technical experiences on previous projects and an understanding of the and the potential environmental parameters affected were identified based on the planned Project’s activities. Using the primary and secondary data from the baseline study, potential sensitive receptors

were identified. The impacts to each sensitive receptor were identified, and the significance of each impact was evaluated based on the assessment criteria as provided in Section 5.4.

7.2.4.1.1 Sediment Plume Impact Assessment

Hydrodynamic models coupled with wave model were set up to simulate the current, tide and wave regimes in the vicinity of Project Site for a full tidal cycle during both Southwest and Northeast Monsoons, i.e. July and January, respectively (refer to Appendix N for details of model setup). Subsequently, a sediment plume model that simulates the dispersion of fine sediment released from the construction activities was carried out based on the hydrodynamic models. The main purpose of carrying out sediment plume modelling is to understand and quantify the effects of sediment plumes from the proposed Project (e.g. suspended sediment concentration [SSC] and increased sedimentation rates) at key marine receptors (e.g. marine sensitive habitats) during the construction phase. The sediment plume impact assessment was carried out using the DELFT3D modelling software, by which the incremental SSC and sedimentation rate were predicted and the impact on sensitive receptors was assessed based on pre-determined tolerance limits as described in Appendix M.

7.2.4.1.2 Underwater Noise Impact Assessment

The potential impacts from Project on underwater noise were assessed through qualitative approach based on primary and secondary data, technical experiences on previous projects and the understanding of the Project's activities during construction phase. The potential sources of Project impacts were identified based on planned Project's activities. Using the primary and secondary data from the baseline study, the potential sensitive receptors were identified. The impacts to each sensitive receptor were identified, and the significance of each impact was evaluated based on the assessment criteria as provided in Section 5.4.

7.2.4.2 Operational Phase

7.2.4.2.1 Hydrodynamic Impact Assessment

Hydrodynamic modelling was conducted to assess the impacts of the proposed development to flow regime, such as flow current and direction in the coastal area surrounding the Project Site during the construction period. The DELFT3D modelling software was used to develop the hydrodynamic model, which was used to assess the existing hydrodynamic conditions and the effects that the operational activities could have on the local flow.

Quantitative methods to evaluate the operational impacts on the hydrodynamics include statistical maps with maximum (95th percentile) flow current for the conditions without/with development, and differences between the without/with development conditions.

7.2.4.2.2 Marine Water Quality Impact Assessment

The potential impacts from Project on water quality were assessed through qualitative approach based on primary and secondary data, technical experiences on previous projects and the understanding of the Project's activities of operational phase. The potential sources of Project impacts were identified based on planned Project's activities. Using the primary and secondary data from the baseline study, the potential sensitive receptors were identified. The impacts to each sensitive receptor were identified, and the significance of each impact was evaluated based on the assessment criteria as provided in Section 5.4.

7.2.4.3 Coastal Morphological Impact Assessment

The proposed development would potentially result in changes in flow currents, which may further lead to morphological changes in the seabed. Morphological modelling was conducted to assess the impacts to the coastal morphology of the proposed development in the long-term. This was carried out using the DELFT3D modelling software, and the impacts were assessed based on the numerical model estimation of the erosion and deposition in the coastal areas surrounding the Project Site.

7.3 Potential Sources of Marine Water Impacts

7.3.1 Construction Phase

Marine water could be potentially exposed to marine water contamination and elevated underwater noise due to the activities taking place during the Project's construction phase. The sources that could potentially impact on the marine water include, but are not limited to, those listed in Table 7-9.

Table 7-9 Potential marine water impacts during the construction phase.

Activity	Potential Source of Impacts	Potential Environmental Parameter Affected and Associated Impacts
Earthworks, pond filling, storage and transportation of filling material transportation	<p>Solid / Toxic Wastes, Liquid Effluent/Stormwater Run-off Generation</p> <ul style="list-style-type: none"> • Elevated suspended solids due to pond filling; • Run-off from exposed soil surface and soil stockpiles; • Run-off from dust suppression sprays; • Elevated suspended solids (e.g. silt and sediment) in site run-off due to heavy rain; • Spoil generation, handling and transport; and • Heavy rain during construction. <p>Marine Construction Noise Sources:</p> <ul style="list-style-type: none"> • Noise generated from vessel traffic. 	<p>Direct impact on marine water quality and indirect impact on nearby ecological sites (e.g. mangrove, seagrass, etc.), aquaculture farm, recreational facilities/activities, etc.:</p> <ul style="list-style-type: none"> • Elevated levels of suspended solids (i.e. sediment plume) leading to increased turbidity and sedimentation rates, solid waste, toxic material, etc; and • Increase in the levels of oil, grease, and other chemical substances. <p>Direct impact on ecology due to elevated underwater noise [R-26]:</p> <ul style="list-style-type: none"> • Mortality, due to damage sustained during sound exposure; • Injury to tissues, disruption of physiology, e.g. internal haemorrhaging, disruption of gas-filled organs such as swim bladders, consequent damage to surrounding tissues. • Damage to auditory system, such as rupture of accessory hearing organs, permanent or temporary auditory threshold shift. • Masking of biologically important sounds, e.g. call of a mate, sound of prey and predators. • Behavioural changes, leading to interruption of normal activities including feeding, schooling, displacement from favoured areas.
Storage and disposal of liquid and solid wastes	<p>Solid / Toxic Wastes, Liquid Effluent/Stormwater Run-off Generation</p> <ul style="list-style-type: none"> • Improper handling, transfer, storage, and disposal of spoil and solid waste (e.g. construction debris); • Improper management of sewage effluents from on-site; and • Inappropriate discharge of domestic sewage and poor maintenance of the portable chemical toilet, storage tanks and septic tanks (e.g. overflow or overload). 	<ul style="list-style-type: none"> • Injury to tissues, disruption of physiology, e.g. internal haemorrhaging, disruption of gas-filled organs such as swim bladders, consequent damage to surrounding tissues. • Damage to auditory system, such as rupture of accessory hearing organs, permanent or temporary auditory threshold shift. • Masking of biologically important sounds, e.g. call of a mate, sound of prey and predators. • Behavioural changes, leading to interruption of normal activities including feeding, schooling, displacement from favoured areas.
Use and storage of chemical substances, and refuelling activities	<p>Improper Management of Chemical Substances</p> <ul style="list-style-type: none"> • Improper handling, transfer, and storage of chemical substances; • Accidental spill and leaks; and • Fuel and lubricants spillage from maintenance of construction vehicles and mechanical equipment. 	<ul style="list-style-type: none"> • Injury to tissues, disruption of physiology, e.g. internal haemorrhaging, disruption of gas-filled organs such as swim bladders, consequent damage to surrounding tissues. • Damage to auditory system, such as rupture of accessory hearing organs, permanent or temporary auditory threshold shift. • Masking of biologically important sounds, e.g. call of a mate, sound of prey and predators. • Behavioural changes, leading to interruption of normal activities including feeding, schooling, displacement from favoured areas.

7.3.2 Operational Phase

Marine can potentially be exposed to hydrodynamic changes, morphological changes, and marine water contamination due to the activities taking place during the Project's operational phase. The sources that could potentially impact on marine water include but are not limited to those listed in Table 7-10.

Table 7-10 Potential hydrology and water quality impacts during the operational phase.

Activity	Potential Source of Impacts	Potential Associated Impacts
Permanent land use change	<ul style="list-style-type: none"> Changes in bathymetry in pond areas 	<p>Marine hydrodynamic and morphological patterns:</p> <ul style="list-style-type: none"> Changes in current regime and reduction of flushing capacity with development (i.e. elevated bathymetry in pond areas); and Modifications of seabed morphology (e.g. bed shear stress) due to the changes in current regime.
Liquid and solid wastes	<p>Improper management of liquid and solid wastes</p> <ul style="list-style-type: none"> Accidental spill and leaks (e.g. during storm event); and Improper handling, transfer, and storage of solid and liquid wastes (e.g. rubbish collection and sewage disposal); 	<p>Surface Water Quality:</p> <ul style="list-style-type: none"> Solid wastes generated from human activities can lead to elevated levels of suspended solids entering waterbodies. The wastes can also block the watercourse and leading to contamination of receiving waterbodies; and Inappropriate discharge of liquid wastes to the watercourse results in contamination of nearby or downstream waterbodies.

7.4 Baseline Findings

The baseline surveys for the Project Site and its vicinity were carried out as per the survey dates stated in Section 5.3.1. This section presents the consolidated baseline findings for hydrology, hydrodynamics, marine sediment quality, water quality from their respective field surveys conducted from September 2021 to September 2022.

7.4.1 Topological and Hydrological Conditions

Topographic survey data was received from the Client on 28th September 2021 and 13th November 2021, and additional topographic survey data was received from the surveyor on 10th November 2021. The topographic data was used to generate elevation and slope maps in ArcGIS for hydrological analysis (Figure 7-5 and Figure 7-6). Using the elevation map, catchment delineation was carried out to identify the catchment areas of the waterbodies in the Project Site and its vicinity and is presented in Figure 7-7.

The elevation map (Figure 7-5) shows three (3) distinctive patches with lower elevations than its immediate surroundings of approximately two metres. The patches with low elevations are approximately -0.5 mSHD and the areas surrounding these patches have approximately +1.5 mSHD. This corresponds with the site observations of a sharp decrease in elevation from the pond bunds to the three (3) ponds. The slope map (Figure 7-6) shows that the slopes that lead downwards towards the Ponds are relatively steep, while the Ponds are mostly flat.

A linear low-lying area located east of Pond 1 can be observed from the elevation and slope maps (Figure 7-5, Figure 7-6). This is where the back mangrove area is located. Furthermore, the elevation and slope maps also show that the Project Site is surrounded by three large hills with steep slopes in the east, north and northwest. The highest point of the hill in the west is approximately +36 mSHD, while the peaks of the northern and north-western hills are both approximately +17 mSHD. These hilly areas contribute runoff into the Project Site.

As shown in Figure 7-7, there are four (4) catchment areas identified to contribute to the three (3) Ponds and the back mangrove area, where Catchment C1 contributes runoff to the back mangrove area, Catchment C2 contributes runoff to Pond 1, Catchment C3 contributes runoff to Pond 2 and Catchment C4 contributes runoff to Pond 3. Catchment C1 has the largest catchment area and is observed to lie entirely outside of the Project Site.

Based on the delineated catchment C1, the runoff from a section of the eastern and northern hills will flow into the back mangrove area. On the other hand, during storm events, Pond 1 receives runoff from a relatively smaller catchment C2. Catchment C3, which feeds Pond 2 during storm events, is slightly larger than C2. Stormwater runoff from Catchment C4 flows into Pond 3, and is observed to have a greater area than Catchment C3. The baseline findings of catchment analysis to support the hydrodynamic modelling.

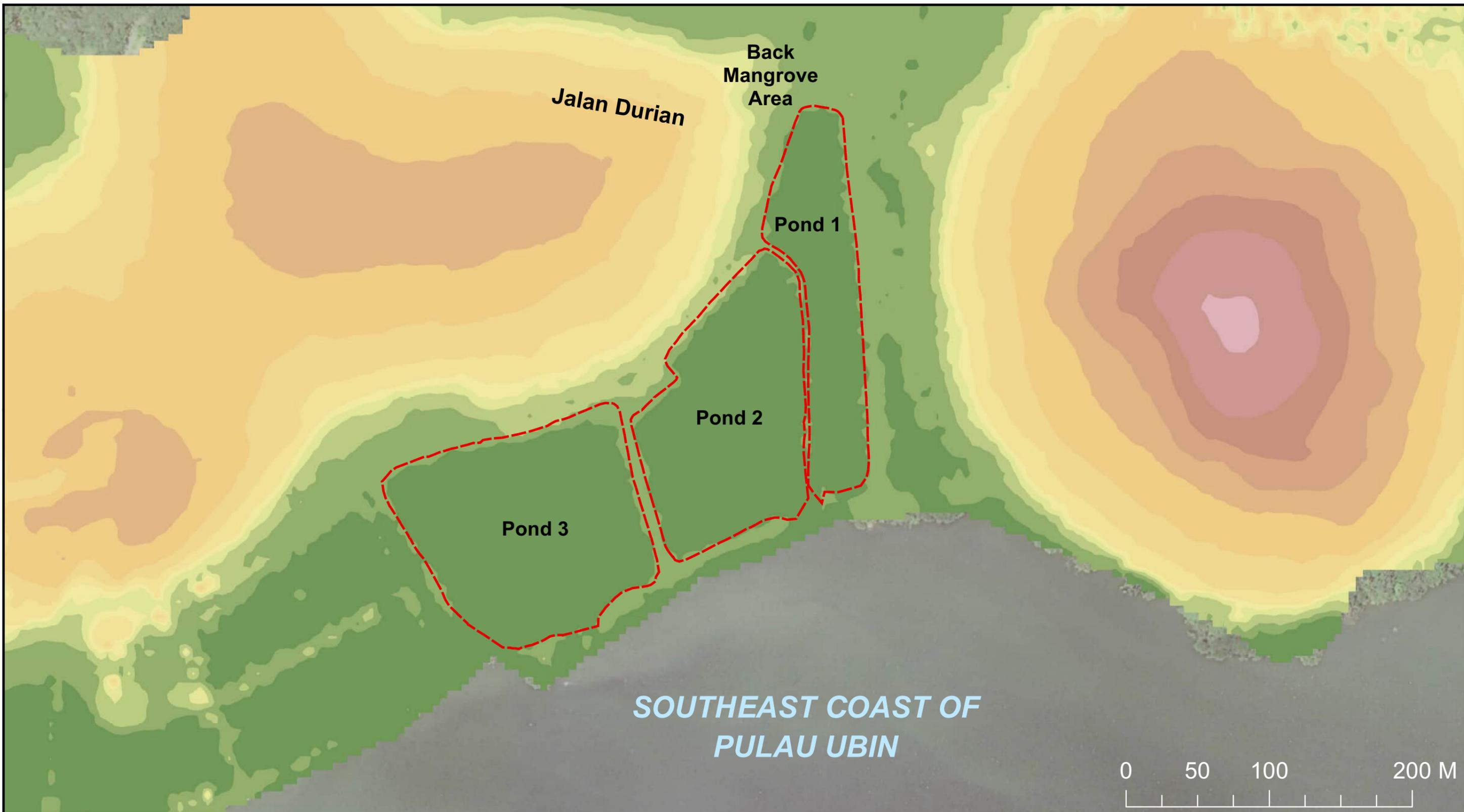

**SOUTHEAST COAST OF
PULAU UBIN**



Legend

Sungei Durian Ponds Project Site

Elevation (mSHD)

-2.0 - +1.0	+10.0 - +15.0
+1.0 - +2.0	+15.0 - +20.0
+2.0 - +3.0	+20.0 - +25.0
+3.0 - +4.0	+25.0 - +30.0
+4.0 - +5.0	+30.0 - +35.0
+5.0 - +7.0	+35.0 - +40.0
+7.0 - +10.0	+40.0 - +45.0
	+45.0 - +50.0

Rev.	Date	By	Description	Chk'd	App'd
-	AUG 2022	CQA	EIA Report	NHT	JAG

Qualified Person Endorsement :
NA

NParks Endorsement : NA

Consultant : **AECOM**

Project Title :
**CONTRACT NPARKS/N/39/2017
CONSULTANCY SERVICES FOR SHORELINE
WORKS IN PULAU UBIN
(MANGROVE RESTORATION OF
SUNGEI DURIAN PONDS)**

Designed CQA	Checked NHT	Approved JAG
	Drawn CQA	Date AUG 2022

Client:

Figure Title :
**Elevation map of the Project
Site and its vicinity**

Figure No. : 7-5	Rev. -	Sheet 1 of 1
CAD File Name : NA		A3

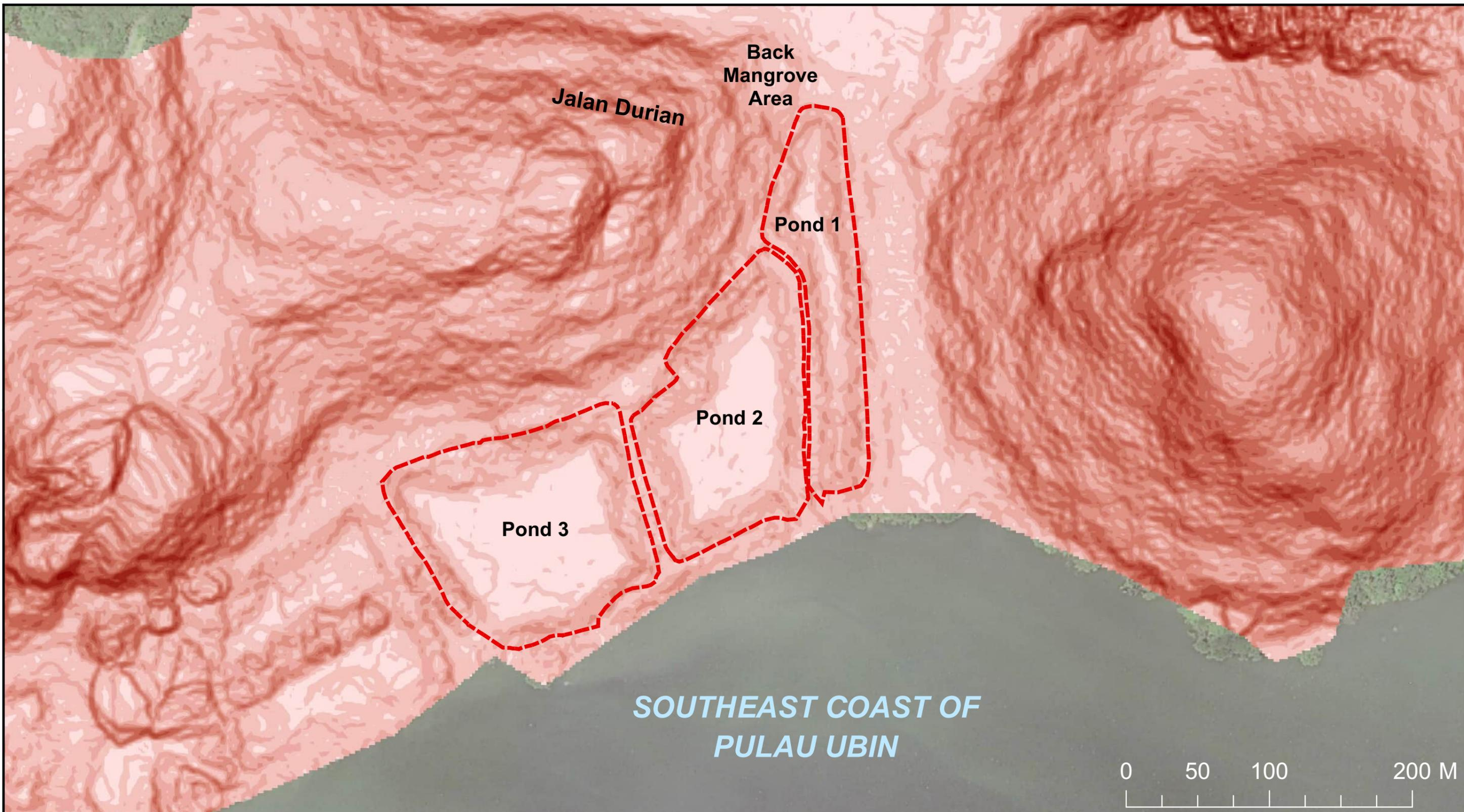

Legend

Sungei Durian Ponds Project Site

Slope (%)

- 0 - 1
- 2 - 5
- 6 - 10
- 11 - 15
- 16 - 20
- 21 - 30
- 31 - 40
- 41 - 50
- 51 - 70
- 71 - 183

N

Rev.	Date	By	Description	Chk'd	App'd
-	AUG 2022	CQA	EIA Report	NHT	JAG

Qualified Person Endorsement :
NA

NParks Endorsement : NA

Consultant : **AECOM**

Project Title :
**CONTRACT NPARKS/N/39/2017
CONSULTANCY SERVICES FOR SHORELINE
WORKS IN PULAU UBIN
(MANGROVE RESTORATION OF
SUNGEI DURIAN PONDS)**

Designed CQA	Checked NHT	Approved JAG
	Drawn CQA	Date AUG 2022

Client:

Figure Title :
**Slope map of the Project
Site and its vicinity**

Figure No. : 7-6	Rev. -	Sheet 1 of 1
CAD File Name : NA		A3

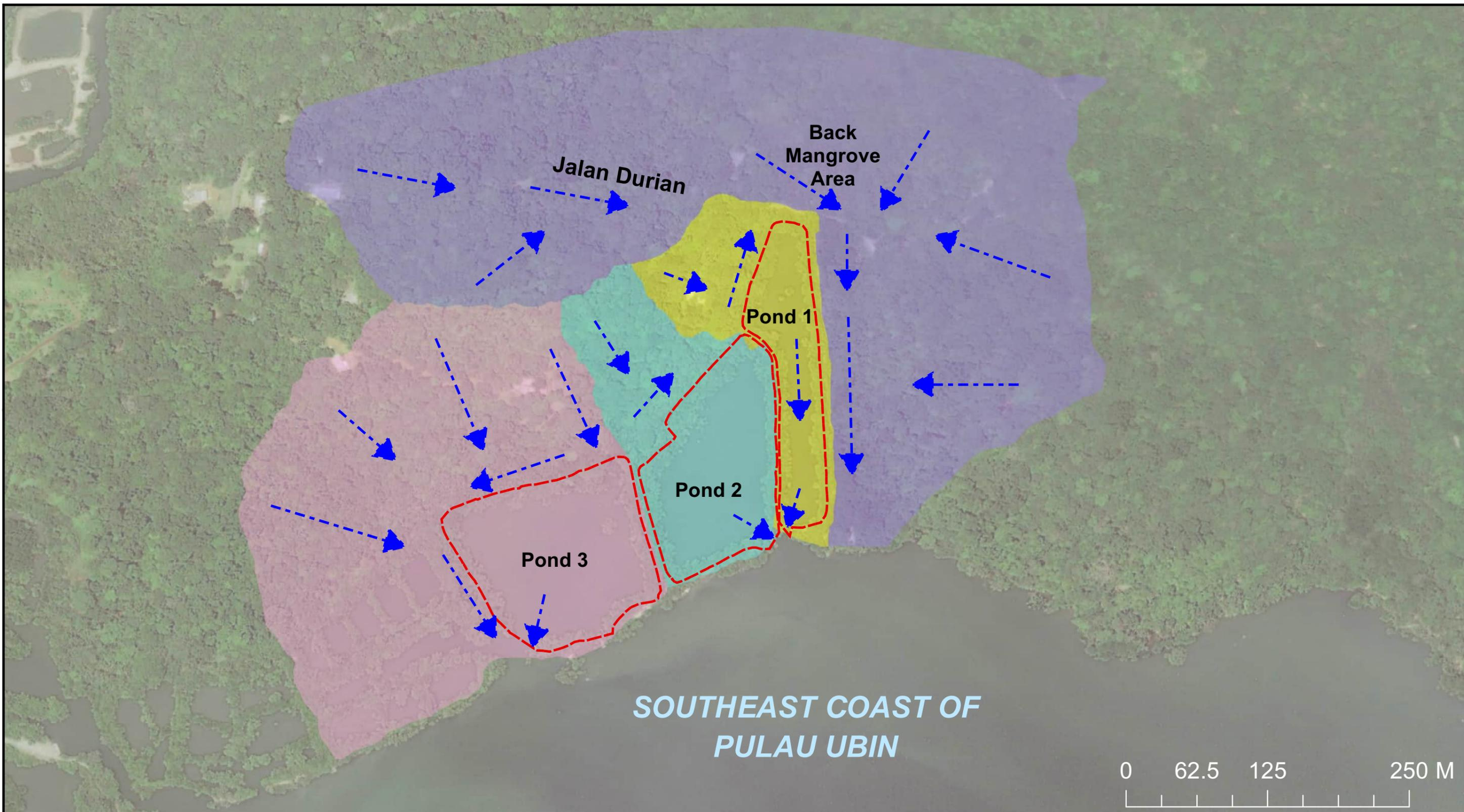

Legend

Sungei Durian Ponds Project Site

Catchment Areas

- C1
- C2
- C3
- C4

Water Flow

N

Rev.	Date	By	Description	Chk'd	App'd
-	AUG 2022	CQA	EIA Report	NHT	JAG

Qualified Person Endorsement :
NA

NParks Endorsement : NA

Consultant :
AECOM

Project Title :
**CONTRACT NPARKS/N/39/2017
CONSULTANCY SERVICES FOR SHORELINE
WORKS IN PULAU UBIN
(MANGROVE RESTORATION OF
SUNGEI DURIAN PONDS)**

Designed CQA	Checked NHT	Approved JAG
	Drawn CQA	Date AUG 2022

Client:

Figure Title :
**Catchment map of the Project
Site and its vicinity**

Figure No. : 7-7	Rev. -	Sheet 1 of 1
CAD File Name : NA		A3

7.4.2 Hydrodynamics

Pulau Ubin is Singapore's second largest offshore natural island (approximately 1,020 ha) located within the Johor Strait near the north-eastern coast of mainland Singapore, just west to the river mouth of Johor River (Figure 7-8). Two monsoon seasons characterise the annual hydrodynamics in Singapore, namely, the Southwest (SW) Monsoon occurring from June to September while the Northeast (NE) Monsoon occurring from December to early March. Late March to May and October to November are inter-monsoon periods with relatively lower wind speed and varying wind directions. During SW Monsoon, the water level in Andaman Sea is higher than that in South China Sea, causing the ingress of water mass from the west, and vice versa during NE Monsoon.

The East Johor Strait is part of the main Johor Strait, a shared waterway between the Singapore mainland and the Malaysian state of Johor Bahru. The East Johor Strait extends from Singapore Strait up to the Singapore-Malaysia causeway (i.e. the Woodland Causeway), at an approximate distance of 4 km. The Woodlands Causeway is a closed bridge structure such that there is no water exchange between the east and west of Johor Strait. Serangoon Harbour refers to the navigation channel along the southern coast of Pulau Ubin.

The overall hydrodynamic study area is shown in Figure 7-8 below.

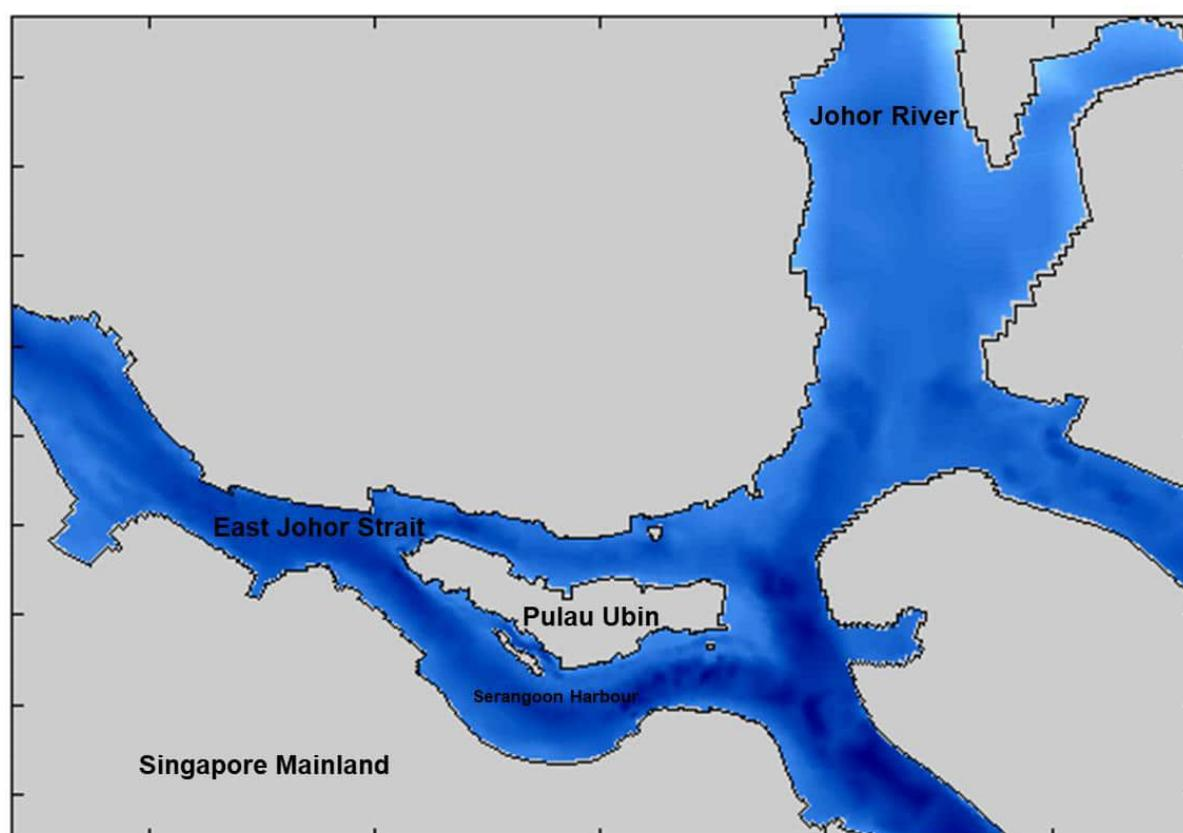

Figure 7-8 Overview of hydrodynamic study area.

7.4.2.1 Bathymetry

Based on the bathymetry survey data provided by client, the bed bathymetry of up to -30 mMSL have been recorded in East Johor Strait. Within the pond areas, the average depth is about -0.4 to -0.3 mMSL, with deepest area of -1.8 mMSL at the opening of Pond 2 (Figure 7-9).

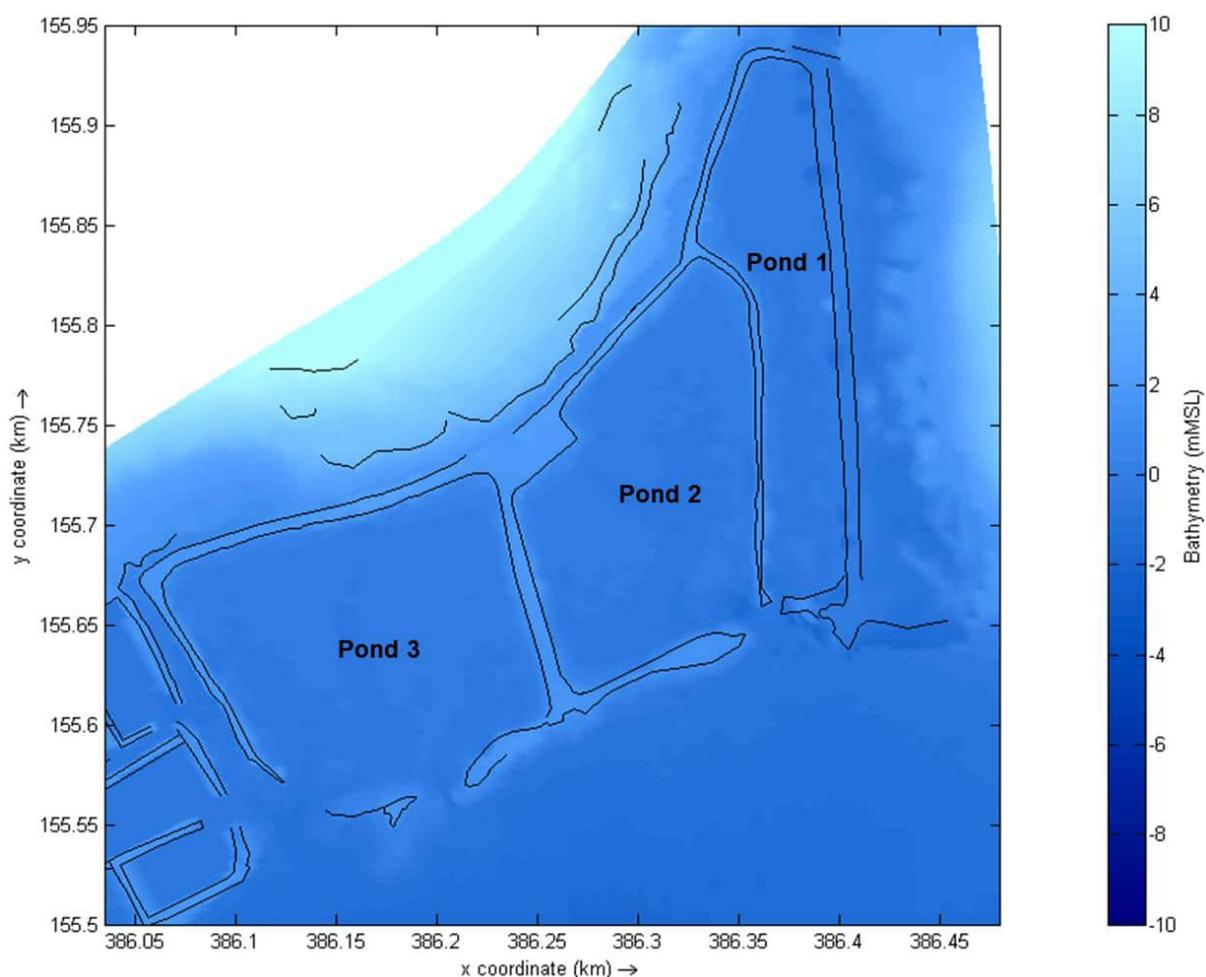

Figure 7-9 Overview of bathymetry of Project Site and its vicinity (mMSL).

7.4.2.2 Current Regime

The hydrodynamic currents of Singapore are dominated by semi-diurnal pattern. Figure 7-10 to Figure 7-13 highlight current characteristics that feature the typical flood and ebb tides during both spring and neap tides. The following results were taken from the well-calibrated and validated hydrodynamic model used in this present study. Further details on the model calibration and validation results can be found in Appendix N. Given the shoreline profile around the Pulau Ubin, currents flow within the Serangoon Harbour are bounded by the narrow waterway and therefore generally flow parallel to the shoreline during both flood and ebb tides. In the vicinity of the Project Site, currents flow in and out of the pond areas along with the tide cycles. During both NE and SW Monsoon seasons, especially at the pond opening areas, the current could reach up to 0.79 m/s during spring tide, while up to 0.56 m/s during neap tide.

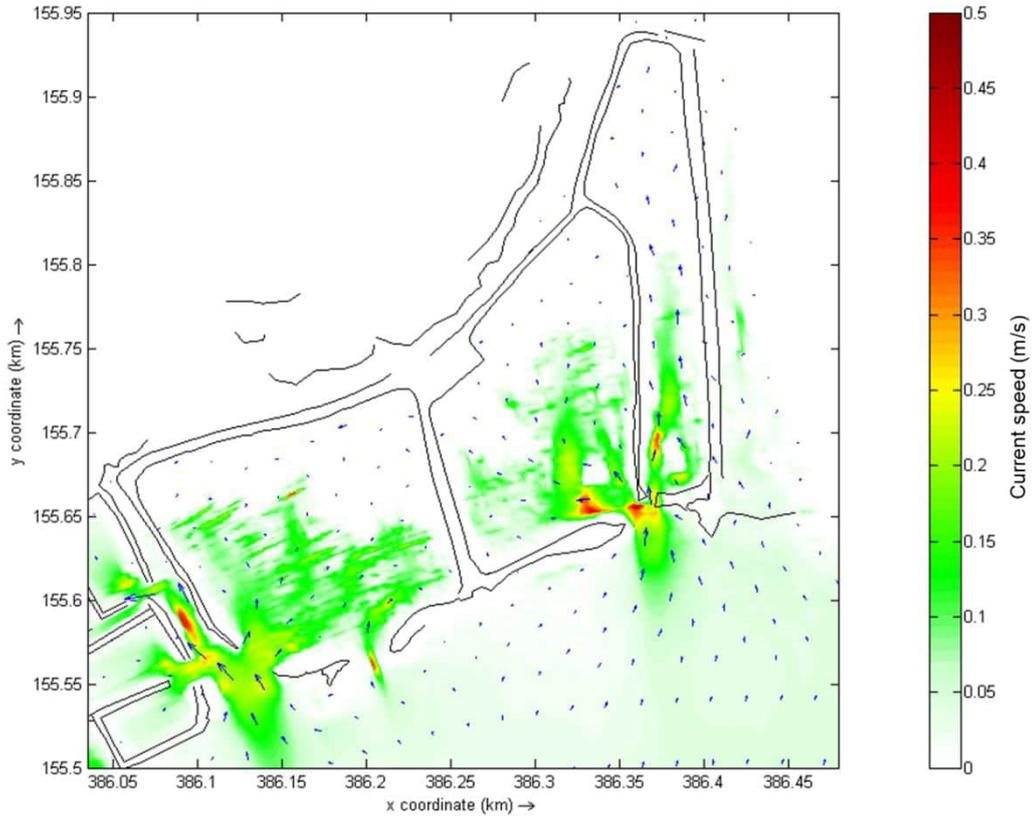

Figure 7-10 Typical spring flood tide currents in the vicinity of Project Site.

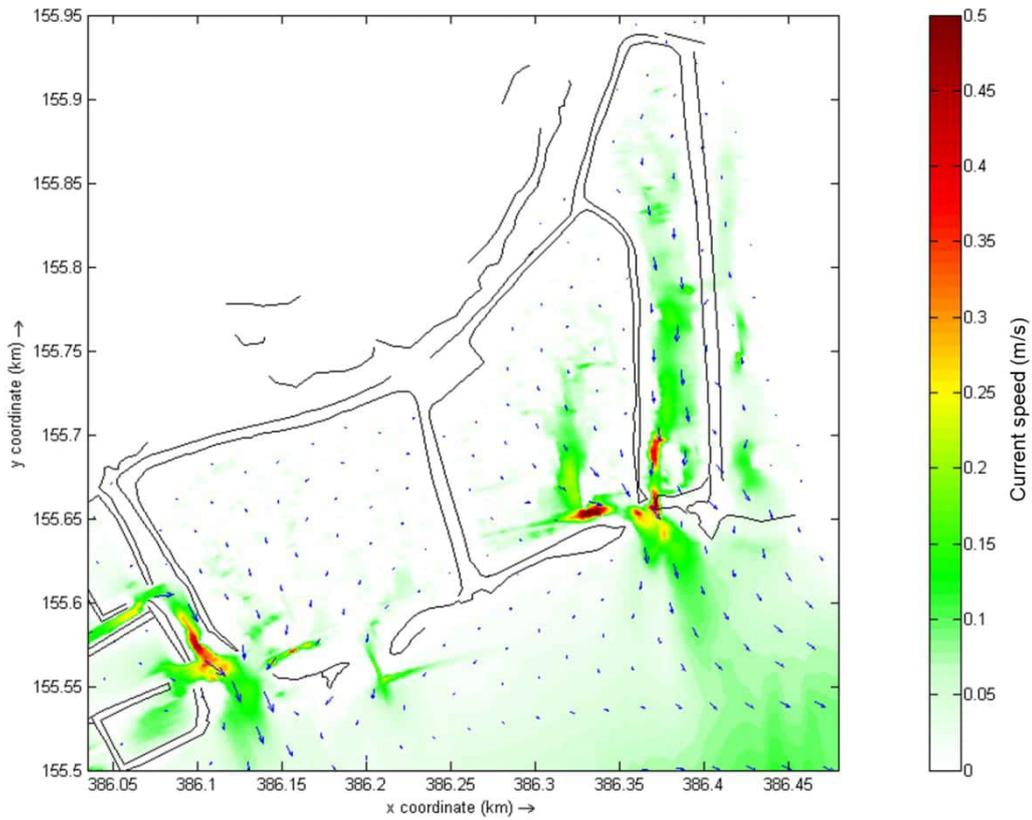

Figure 7-11 Typical spring ebb tide currents in the vicinity of Project Site.

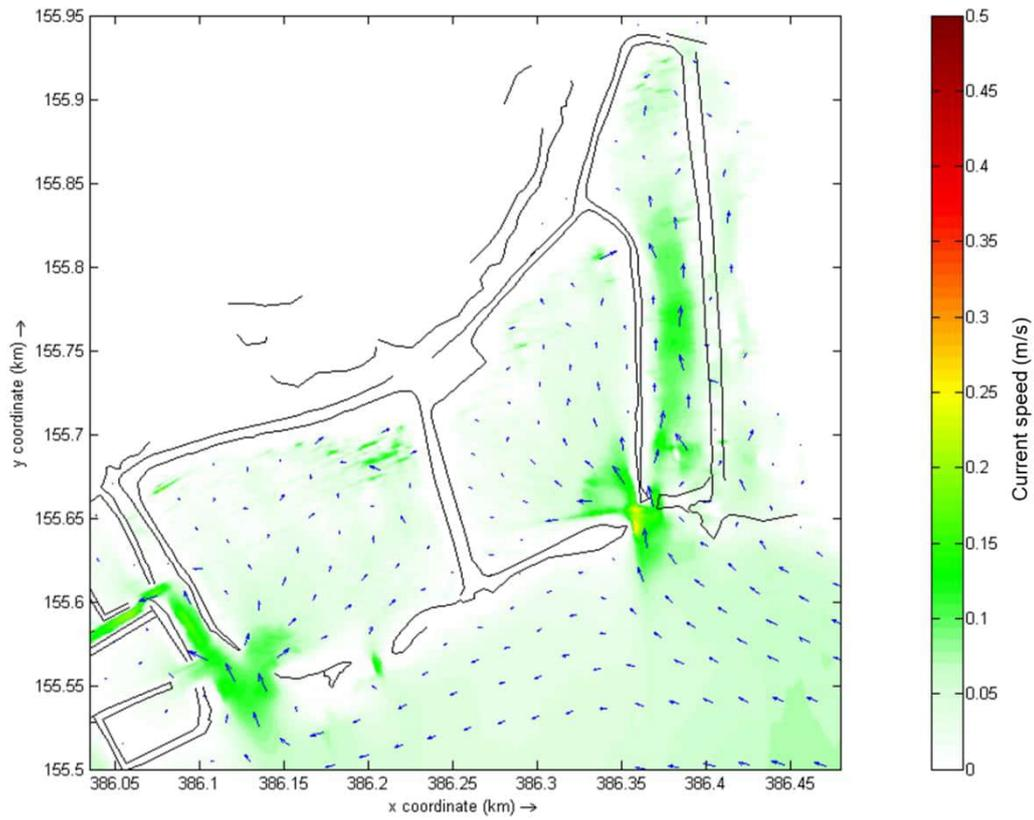

Figure 7-12 Typical neap flood tide currents in the vicinity of Project Site.

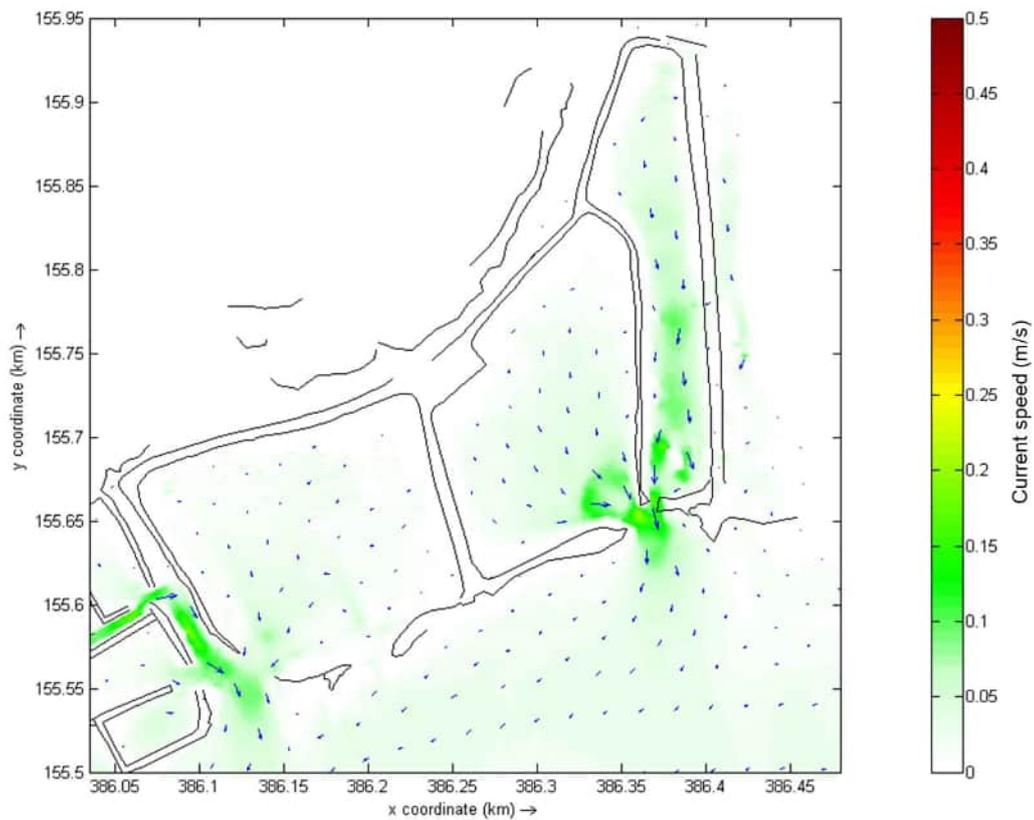

Figure 7-13 Typical neap ebb tide currents in the vicinity of Project Site.

7.4.2.3 Wave Climate

Due to the sheltered location of the whole Singapore, wave penetration to Singapore Strait and Serangoon Harbour is low and the wave climate typically mild. The wave fields have significant wave height levels (i.e. mean wave height of the highest third of the waves) less than 0.5m and confirms the mild wave environment. Environmental wave energy is greatest in the east (Chek Jawa Wetlands), decreasing westward along the shoreline.

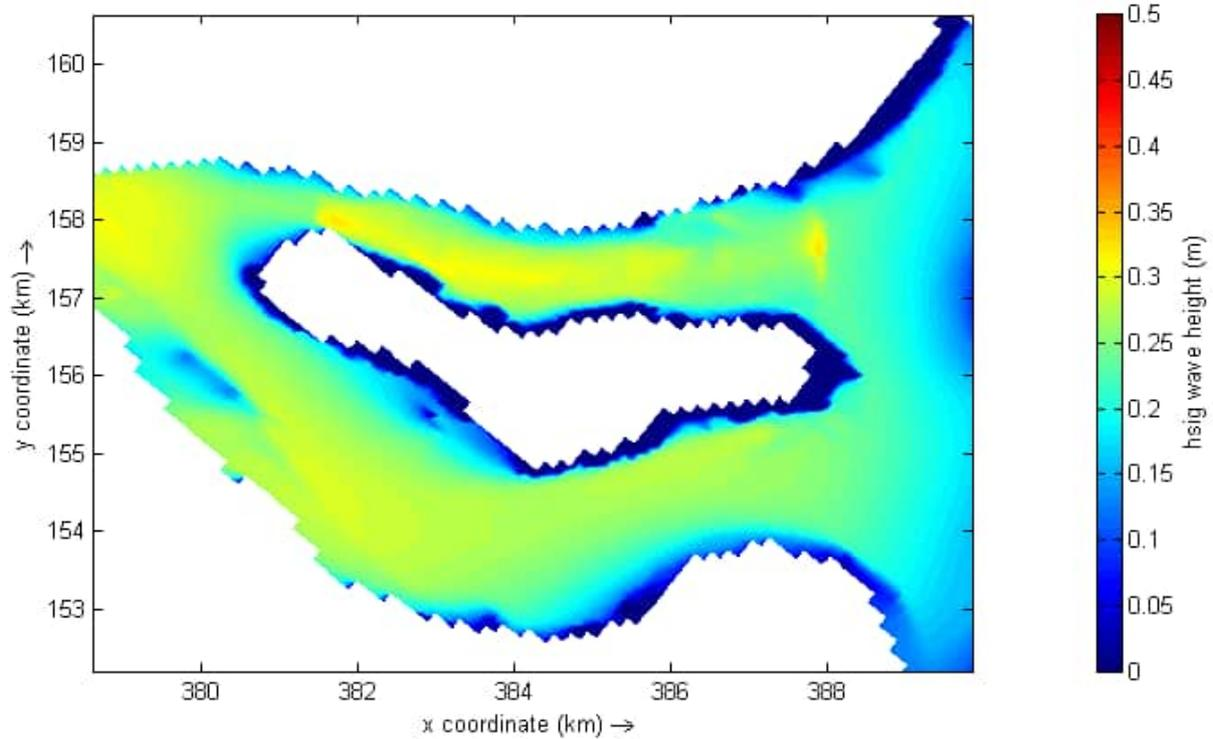

Figure 7-14 Typical wave climate (significant wave height – h_{sig}) surrounding Pulau Ubin.

7.4.2.4 Water Depth

Based on the well calibrated modelling results from well calibrated and validated hydrodynamic model used in present study (refer to Appendix N), the simulated baseline water depth indicates that the area in the vicinity of Project Site experiences a tidal range of around 3.4m (Figure 7-15).

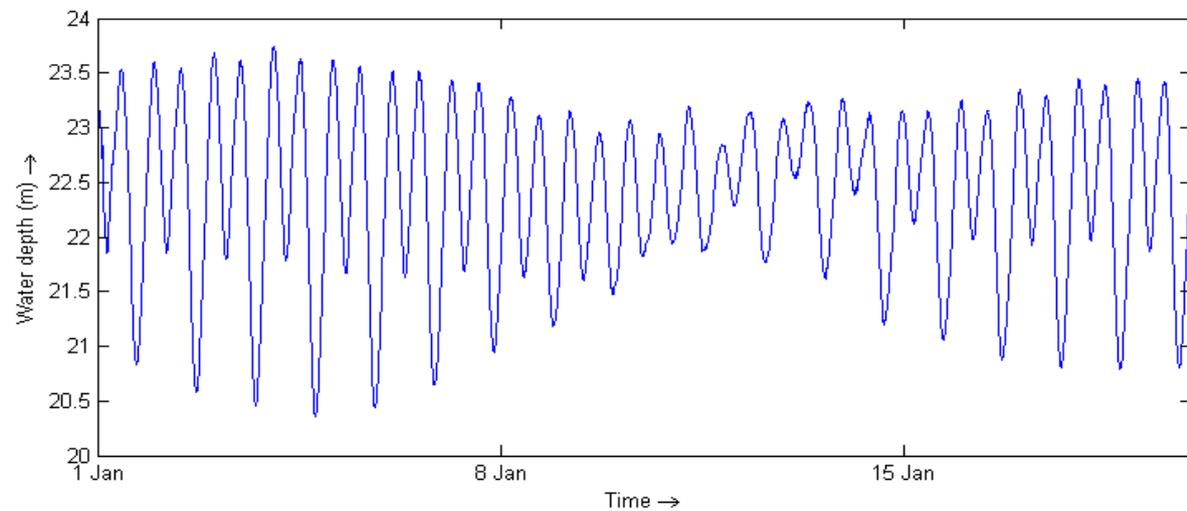

Figure 7-15 Simulated water depth in the vicinity of Project Site.

7.4.3 Marine Sediments

Baseline sediment quality and characteristics were studied for all sampled sediments within the Project Site and its vicinity, and the findings are presented in the sections below. The laboratory reports of the sediment characteristics and quality are consolidated in Appendix P.

7.4.3.1 Sediment Characteristics

The general composition of the sediments across the eight (8) sampling locations are presented in Table 7-11.

Generally, all eight (8) sediment samples have low gravel proportions, which implies that there were no large particulates present across all samples. It was found that the sediments collected from the middle of each pond (i.e. S3, S5, S6) have a higher percentage (>50%) of silt. Samples collected near the bunds (i.e. S1, S2, S7) had relatively equal sand and silt proportions, with an exception of the sediments near the bund in Pond 2 (i.e. S4) which has very high percentage of sand. The coastal area (i.e. S8) was found to have a higher percentage of sand.

Such particle size information of the sediments at these sampling locations in the vicinity of Project Site was further used as inputs for the morphological and sediment plume modelling.

Table 7-11 Particle size distribution (in %) of the sediment at survey locations.

Sampling Location		Soil Composition (%)			
		Gravel	Sand	Silt	Clay
S1	Back mangrove area	0	40	44	16
S2	North-eastern corner of Pond 1	4	40	40	16
S3	Middle of Pond 1	0	16	64	20
S4	North-western corner of Pond 2	9	65	18	8
S5	Middle of Pond 2	5	20	54	21
S6	Middle of Pond 3	9	22	42	27
S7	North-western corner of Pond 3	7	51	31	11
S8	Coastal area outside of the Ponds	8	71	16	5

7.4.3.2 Sediment Quality

The sediment quality of samples collected from the Project Site and secondary data of the sediment proposed fill material source site were analysed below.

7.4.3.2.1 Sediments from Project Site

Sediment quality analysis was carried out on the sediment samples collected on 15th December 2021 and 9th March 2022 at locations shown in Figure 7-3. The results of the sediment quality survey provided information on the potential pollutants that are bound to the sediments. To assess the possible release of pollutants that may arise due to sediment resuspension during construction works, the sediment quality was assessed against Singapore MPA's General Guidelines on the Requirements for Application on Dredging and Dumping Works. Where the MPA guidelines does not have the necessary limits for comparison, reference was made to other standards that were published overseas for guidance. The sediment quality of the Project Site was compared to Sediment Quality Assessment Guidelines for Florida Coastal Waters and Ontario Guidelines for the Protection and Management of Aquatic Sediment Quality to assess the baseline sediment quality relative to recommended limits for environmental protection of aquatic flora and fauna. These criteria were listed in Table 7-5. It should be noted that there are two limits of detection (i.e. 10 mg/kg and 0.1 mg/kg) for the total oil and grease parameter. This is because four (4) of the sediment were sampled during the first round of sampling (i.e. 15th December 2021) for the planning of the engineered soil mix, whereas the other four (4) samples were sampled for this Study (i.e. 9th March 2022). Nevertheless, the amount of oil and grease present in the sample was found to be well below the detection limit.

Most of the tested heavy metals (i.e. Cd, Cr, Cu, Ni, Pb, Zn, Hg) were found to be below the Singapore MPA's guideline values, except for the sediments collected from the back mangrove area (S1) which has a minor exceedance in the limit (i.e. 30 mg/kg) for arsenic at 30.5 mg/kg. The As levels were found to exceed the Threshold Effects Level (TEL) (i.e. 7.24 mg/kg) of sediment guidelines from Florida and Severe Effects Level as well as the Low Effects Level (LEL) (i.e. 6 mg/kg) sediment guidelines from Ontario. However, the concentration of arsenic is still below both the Probable Effects Level (PEL) (i.e. 41.6 mg/kg) as defined in the Florida sediment guidelines and Severe Effects Level (SEL) (i.e. 33 mg/kg) as defined in the Ontario sediment guidelines. Generally, mangrove plants are able to uptake and accumulate arsenic, are known to serve as a sink and source for this heavy metal. High levels of arsenic were also found in mangroves in other countries, such as Brazil (i.e. up to 70 mg/kg) and Australia (i.e. 0.52 to 35 mg/kg) [P-57]. Furthermore, given that the water quality sample collected from the same location (WQ1B) was found to have low arsenic concentrations of 2.84 µg/L which is significantly lower than the water quality limits of 120 µg/L, it is unlikely that there is a transfer of arsenic from the surface of the sediments into the aqueous phase.

Cadmium concentrations at the back mangrove area (S1) was 0.67 mg/kg, which exceeded the LEL of sediment guidelines from Ontario (i.e. 0.6 mg/kg). Copper concentration was found to exceed both sediment guidelines from Ontario and Florida at Pond 1 (S2, S3), middle of Pond 2 (S5) and middle of Pond 3 (S6). Mercury concentrations was also found to exceed the Florida sediment guidelines at the middle of Pond 1 (S3), Pond 2 (S5), Pond 3 (S6), while the mercury levels detected at Pond 1 (S3) also additionally exceeded the Ontario guidelines.

The amount of nutrients (TP, TN) in the sediment samples across all sites was low and was considered far below the LEL and SEL limits of the Ontario sediment guidelines. Oil and grease levels were below the detection limit for all sampling stations, which indicates that there is no accumulation of petroleum hydrocarbons in the sediments.

In conclusion, the sediment quality from the back mangrove area, within the three (3) ponds and near the coastal area south of the Site is relatively good, establishing that any future contamination identified within the Project Site is unlikely to originate from the existing sediments.

Table 7-12 Sediment quality at each sediment sampling location at Project Site.

Location Parameters	Back Mangrove Area	Pond 1			Pond 2		Pond 3		Coastal Area Outside of Ponds	Average	Singapore General Guidelines for Dredging/ Dumping Works	Sediment Quality Assessment Guidelines for Florida Coastal Waters (FDEP, 1994)		Ontario Guidelines for the Protection and Management of Aquatic Sediment Quality (MEE, 1993)	
	S1	S2	S3	S4	S5	S6	S7	S8			TEL ⁵	PEL ⁶	LEL ⁷	SEL ⁸	
Arsenic, As (mg/kg)	30.5	15.5	18.1	13.6	17.4	14.0	17.2	13.3	17.45	30	7.24	41.6	6	33	
Cadmium, Cd (mg/kg)	0.67	0.42	0.49	0.44	0.53	0.42	0.36	0.31	0.46	1	0.676	4.21	0.6	10	
Chromium, Cr (mg/kg)	21.2	21.5	21.4	17.0	23.1	21.8	22.6	9.25	19.73	50	52.3	160	26	110	
Copper, Cu (mg/kg)	15.3	19.2	19.1	13.8	20.0	19.0	15.2	7.74	16.17	55	18.7	108	16	110	
Nickel, Ni (mg/kg)	5.62	12.5	12.8	10.1	14.2	12.9	9.62	4.61	10.29	35	15.9	42.8	16	75	
Lead, Pb (mg/kg)	25.5	22.6	24.4	15.6	25.3	25.9	20.2	11.1	21.33	65	30.2	112	31	250	
Zinc, Zn (mg/kg)	54.0	70.3	67.2	54.4	75.5	68.4	46.2	33.5	58.69	150	124	271	120	820	
Mercury, Hg(mg/kg)	0.13	0.069	0.21	0.046	0.19	0.15	0.059	0.074	0.12	0.8	0.13	0.696	0.2	2	
Total Phosphorus, TP (% by dry mass)	0.065	0.054	0.010	0.044	0.011	0.011	0.043	0.0084	0.031	N.A.	N.A.	N.A.	600	2000	
Total Nitrogen, TN (% by dry mass)	0.24	0.22	0.22	0.16	0.22	0.21	0.25	0.098	0.20	N.A.	N.A.	N.A.	550	4800	

Parameters	Location	Pond 1			Pond 2		Pond 3		Coastal Area Outside of Ponds	Average	Singapore General Guidelines for Dredging/ Dumping Works	Sediment Quality Assessment Guidelines for Florida Coastal Waters (FDEP, 1994)		Ontario Guidelines for the Protection and Management of Aquatic Sediment Quality (MEE, 1993)	
	Back Mangrove Area	S1	S2	S3	S4	S5	S6	S7				S8	TEL ⁵	PEL ⁶	LEL ⁷
Oil & Grease¹⁰ (mg/kg)		<10	<10	<0.1	<10	<0.1	<0.1	<10	<0.1	<10	N.A.	N.A.	N.A.	1500 ⁹	

Notes:

- Brown** values indicates that the data exceeds all three sediment quality guidelines.
- Red** values indicates that the data exceeds the Sediment Quality Assessment Guidelines for Florida Coastal Waters.
- Blue** values indicates that the data exceeds the Ontario Guidelines for the Protection and Management of Aquatic Sediment Quality.
- Purple** values indicates that the data exceeds the Sediment Quality Assessment Guidelines for Florida Coastal Waters and Ontario Guidelines for the Protection and Management of Aquatic Sediment Quality.
- TEL – Threshold Effects Level, represents the concentration below which adverse biological effects are expected to occur rarely.
- PEL – Probable Effects Level, defines the level above which adverse effects are expected to occur frequently.
- LEL – Low Effects Level
- SEL – Severe Effects Level
- Only open water disposal guidelines for Oil & Grease are available.
- '<10' means lower than 10 mg/kg, which is the parameter's detection limit; while '<0.1' means lower than 0.1 mg/kg, which is the parameter's detection limit.

7.4.3.2.2 Sediments from Proposed Fill Material Source Site

Secondary data of the sediment quality of the proposed fill material from Noordin Beach and Mamam Beach at Northern Pulau Ubin was assessed against the three sediment quality guidelines listed in Section 7.2.3.4. The sampling locations and their sampling rationale were presented in Table 7-13. This was to evaluate the potential impacts on marine flora and fauna from the full range of natural processes governing the fate and transport of contaminants that may be leached from the fill material. Six (6) sediment samples were collected from the selected locations of the four (4) headlands at Northern Pulau Ubin, with five (5) samples (N1, N2, N3, N4 and N5) from Noordin Beach and one (1) from Mamam Beach (N6).

Arsenic (As) levels exceeded both the Threshold Effects Level (TEL) of the Ontario guidelines (i.e. 6 mg/kg) and the Low Effect Level (LEL) of Florida guidelines (i.e. 7.24 mg/kg) in samples collected from the site of Headlands 1 and 2 at Noordin Beach (N1, N2 and N3). The As concentration at the site of Headlands 2 at Noordin Beach (N4) (i.e. 6.10 mg/kg) exceeded the LEL of Ontario guidelines. To note, the exceedances of As concentrations were all just slightly above the limit, and these sediment samples were found to have a better sediment quality than the sediments within the Project Site (Table 7-12). This indicates that the potential impacts of the contaminants in the fill material on aquatic life would be negligible compared to the existing conditions. This would be further elaborated in Section 7.7.1.1.1.

Chromium concentrations at the site of Headlands 2 area at Noordin Beach (N4) was also found to exceed the LEL of Ontario guidelines. Lead (Pb) concentration was found to be 77.5 mg/kg at Mamam Beach (N6), which exceeds all three guidelines (i.e. Singapore General Guidelines for Dredging/Dumping works, TEL of Ontario guidelines and LEL of Florida guidelines). Given the exceedance of Singapore's guidelines, the sediments from N6 at Mamam Beach is deemed contaminated and would not be utilised as fill material for this Project. Instead, the dredged sediments would be transported and disposed of in the Pulau Semakau landfill.

Table 7-13 Sediment quality sampling locations at Noordin Beach and Mamam Beach.

S/N	Monitoring Location	Sampling Depth	Justification
N1	Noordin Beach – Headlands 1	4 metres below seabed	To capture the sediment quality of the sediments located 4 metres below the proposed Headlands 1 which would be potentially dredged during construction.
N2	Noordin Beach – Headlands 1	9 metres below seabed	To capture the sediment quality of the sediments located 9 metres below the proposed Headlands 1 which would be potentially dredged during construction.
N3	Noordin Beach – Headlands 2	2 metres below seabed	To capture the sediment quality of the sediments located 2 metres below the proposed Headlands 2 which would be potentially dredged during construction.
N4	Noordin Beach – Headlands 2	7 metres below seabed	To capture the sediment quality of the sediments located 7 metres below the proposed Headlands 2 which would be potentially dredged during construction.
N5	Noordin Beach – Headlands 3	2 metres below seabed	To capture the sediment quality of the sediments located 2 metres below the proposed Headlands 3 which would be potentially dredged during construction.
N6	Mamam Beach – Headlands 4	2 metres below seabed	To capture the sediment quality of the sediments located 2 metres below the proposed Headlands 4 which would be potentially dredged during construction.

Table 7-14 Sediment quality at each proposed fill material source site.

Location	Noordin Beach						Mamam Beach	Average	Singapore General Guidelines for Dredging/ Dumping Works	Sediment Quality Assessment Guidelines for Florida Coastal Waters (FDEP, 1994)		Ontario Guidelines for the Protection and Management of Aquatic Sediment Quality (MEE, 1993)	
	Headland 1		Headland 2		Headland 3	Headland 4	TEL ⁵			PEL ⁶	LEL ⁷	SEL ⁸	
Sample No.	N1	N2	N3	N4	N5	N6							
Arsenic, As (mg/kg)	8.75	8.03	7.84	6.10	1.83	1.38	5.66	30	7.24	41.6	6	33	
Cadmium, Cd (mg/kg)	0.39	0.40	0.43	0.53	0.27	0.34	0.39	1	0.676	4.21	0.6	10	
Chromium, Cr (mg/kg)	20.90	22.90	20.60	29.20	3.54	5.08	17.04	50	52.3	160	26	110	
Copper, Cu (mg/kg)	6.89	7.26	7.26	3.81	16.00	1.68	7.15	55	18.7	108	16	110	
Nickel, Ni (mg/kg)	12.90	14.20	13.90	4.18	1.83	6.51	8.92	35	15.9	42.8	16	75	
Lead, Pb (mg/kg)	24.30	24.00	23.70	6.99	20.40	77.5	29.48	65	30.2	112	31	250	
Zinc, Zn (mg/kg)	44.00	46.60	44.10	9.98	23.70	5.11	28.92	150	124	271	120	820	
Mercury, Hg (mg/kg)	0.060	0.053	0.056	0.062	0.0098	0.062	0.050	0.8	0.13	0.696	0.2	2	
Total Phosphorus, TP (% by dry mass)	0.040	0.021	0.022	0.016	0.007	0.0049	0.0185	N.A.	N.A.	N.A.	600	2000	

Location	Noordin Beach					Mamam Beach	Average	Singapore General Guidelines for Dredging/ Dumping Works	Sediment Quality Assessment Guidelines for Florida Coastal Waters (FDEP, 1994)		Ontario Guidelines for the Protection and Management of Aquatic Sediment Quality (MEE, 1993)	
	Headland 1		Headland 2		Headland 3	Headland 4			TEL ⁵	PEL ⁶	LEL ⁷	SEL ⁸
Sample No.	N1	N2	N3	N4	N5	N6						
Total Nitrogen, TN (% by dry mass)	0.07	0.079	0.079	0.024	0.0064	0.0046	0.0438	N.A.	N.A.	N.A.	550	4800
Oil & Grease¹⁰ (mg/kg)	<10	124	<10	286	<10	127	179	N.A.	N.A.	N.A.	1500 ⁹	

Notes:

- Brown** values indicates that the data exceeds all three sediment quality guidelines.
- Red** values indicates that the data exceeds the Sediment Quality Assessment Guidelines for Florida Coastal Waters.
- Blue** values indicates that the data exceeds the Ontario Guidelines for the Protection and Management of Aquatic Sediment Quality.
- Purple** values indicates that the data exceeds the Sediment Quality Assessment Guidelines for Florida Coastal Waters and Ontario Guidelines for the Protection and Management of Aquatic Sediment Quality.
- TEL – Threshold Effects Level, represents the concentration below which adverse biological effects are expected to occur rarely.
- PEL – Probable Effects Level, defines the level above which adverse effects are expected to occur frequently.
- LEL – Low Effects Level.
- SEL – Severe Effects Level.
- Only open water disposal guidelines for Oil & Grease are available.
- '<10' means lower than 10 mg/kg, which is the parameter's detection limit; while '<0.1' means lower than 0.1 mg/kg, which is the parameter's detection limit.

7.4.4 Water Quality

Water samples were collected at six (6) water quality sampling stations strategically located to assess the baseline water quality in the various waterbodies within and in the vicinity of the Project Site, as well as the coastal and offshore water quality near the sensitive receptors (i.e. aquaculture farms).

Figure 7-2 shows the location of the water quality stations within the Project Site and its vicinity, while Table 7-1 summarises the rationale for the selection of each water quality sampling station. One (1) water quality sampling station (WQ1A/B) was located along the back mangrove area, to capture its existing water quality. During Neap-Flood tide conditions, the upstream of the back mangrove area (WQ1B) had optimal conditions for water quality sampling (i.e. water levels were sufficiently high for sample collection). However, during Neap-Ebb tide conditions, the water levels at the upstream (WQ1B) was deemed too low for sampling, and thus samples were collected further downstream instead (WQ1A). Samples were collected at the downstream (WQ1A) for subsequent Spring-Ebb and Spring-Flood conditions as well. Three (3) sampling stations were located Pond 1 (WQ2), Pond 2 (WQ3) and Pond 3 (WQ4), to capture the water quality from each Pond. Station WQ5 was located at the coastal area just south of the Ponds, to capture the existing water quality of the coastal waters near Serangoon Harbour. Station WQ6 is located offshore, in the vicinity of the aquaculture farms to capture the existing water quality near this sensitive receptor.

For all six (6) sampling stations, the marine water samples were collected during Neap-Flood, Neap-Ebb, Spring-Flood and Spring-Ebb tidal conditions. A total of twenty-four (24) water quality samples were collected from March 2022 to June 2022. Table 7-15 shows the dates of each sampling event.

The surface water quality results were summarised and presented in Table 7-16 and the ex-situ laboratory reports are consolidated in Appendix P. Surface water quality results were assessed against NEA Trade Effluent Discharge limits, ASEAN Marine Water Quality Criteria (AMWQC) and multiple international water quality criteria for aquatic life (as shown in Section 7.2.3.3). The relevant limits and guidelines for water quality parameters were summarised in Table 7-4; however, where no guidelines exist, the monitored results would be considered as the baseline. It should be noted that the surface water quality of any runoff generated from the Project's activities during both construction and operational phases should comply with the NEA allowable limits for discharge into an uncontrolled watercourse.

Table 7-15 Water quality monitoring schedule.

Sampling Event		Neap Tide (Both Flood & Ebb Tide)		Spring Tide (Both Flood & Ebb Tide)	
		9 th March 2022	10 th June 2022	7 th April 2022	15 th June 2022
Sampling Location					
WQ1	Back mangrove area	Sampled	-	Sampled	-
WQ2	Pond 1	Sampled	-	Sampled	-
WQ3	Pond 2	Sampled	-	Sampled	-
WQ4	Pond 3	Sampled	-	Sampled	-
WQ5	Coastal area just south of Project Site	Sampled	-	Sampled	-
WQ6	Offshore area, in the vicinity of aquaculture farms	-	Sampled	-	Sampled

Note:

- '-' indicates that sampling was not carried out on the particular date, but instead was done during another sampling event instead.

Table 7-16 Water quality results

Parameter		WQ1A and WQ1B	WQ2	WQ3	WQ4	WQ5	WQ6	NEA Trade Effluent Discharge Limits ¹	Water Quality Criteria for Aquatic Life ²
Site		Back Mangrove Area	Pond 1	Pond 2	Pond 3	Coastal Area Near Project Site	Offshore Area Near Aquaculture Farms		
pH	Spring Flood	7.40	8.10	8.10	8.10	8.10	7.6	6 – 9	6.5 – 9 (USEPA)
	Spring Ebb	7.70	8.10	8.10	8.10	8.10	7.8		
	Neap Flood	6.40	8.10	8.10	8.00	8.00	8.30		
	Neap Ebb	7.10	8.00	8.20	8.10	8.10	7.90		
	Average	7.15	8.08	8.13	8.08	8.08	7.90		
Temperature (°C)	Spring Flood	26.78	29.61	29.32	29.61	29.89	30.39	≤ 45	≤ 2°C above the maximum ambient temperature
	Spring Ebb	28.39	29.56	29.67	29.56	29.67	30.67		
	Neap Flood	28.61	31.28	30.75	31.82	31.83	32.07		
	Neap Ebb	28.94	30.72	29.83	31.33	31.56	30.50		
	Average	28.18	30.29	29.89	30.58	30.74	30.91		
Salinity (PSU)	Spring Flood	28.97	27.47	27.28	27.37	27.46	27.695	-	-
	Spring Ebb	27.65	27.35	27.42	27.41	27.52	27.82		
	Neap Flood	4.82	28.36	28.24	28.44	28.59	26.68		
	Neap Ebb	28.79	28.12	29.05	28.15	28.26	27.38		
	Average	22.56	27.83	28.00	27.84	27.96	27.39		
Conductivity (µS/cm)	Spring Flood	46,376	46,675	46,139	46,519	42,887	47,709	-	-
	Spring Ebb	45,887	46,428	46,638	46,515	46,785	48,119		
	Neap Flood	9,299	49,536	48,865	50,105	50,357	47,551		
	Neap Ebb	48,102	48,651	49,283	49,218	49,594	47,298		
	Average	37,416	47,823	47,731	48,089	47,406	47,669		
Total Dissolved Solids, TDS (mg/L)	Spring Flood	29,170	27,881	27,700	27,795	27,877	28,110	-	-
	Spring Ebb	28,019	27,772	27,842	27,824	27,931	28,234		
	Neap Flood	5,657	28,740	28,617	28,821	28,962	27,227		
	Neap Ebb	29,064	28,506	29,321	28,546	28,658	27,827		
	Average	22,977	28,225	28,370	28,246	28,357	27,850		
Dissolved Oxygen, DO (mg/L)	Spring Flood	0.13	6.67	6.525	6.61	6.94	5.74	-	≥ 4.0
	Spring Ebb	3.95	7.00	6.79	6.94	7.98	5.94		
	Neap Flood	2.25	6.21	5.86	5.37	5.83	13.64		
	Neap Ebb	1.31	6.06	6.02	6.58	6.40	10.14		
	Average	1.91	6.49	6.30	6.37	6.78	8.86		
Turbidity (NTU)	Spring Flood	104.84	10.12	42.04	41.06	15.76	4.305	-	-
	Spring Ebb	5.53	21.02	17.46	23.86	2.76	2.11		
	Neap Flood	17.64	14.66	12.32	25.24	158.68	3.36		
	Neap Ebb	6.67	6.15	5.88	7.40	9.05	3.35		
	Average	33.67	12.99	19.42	24.39	46.56	3.28		
Total Suspended Solids, TSS (mg/L)	Spring Flood	9.10	31.30	19.00	34.60	59.50	7.30	50	≤ 10% increase over seasonal average
	Spring Ebb	12.00	9.90	8.90	18.30	6.50	5.70		
	Neap Flood	17.00	25.00	19.17	69.30	40.33	10.20		
	Neap Ebb	10.00	10.30	10.70	11.30	13.10	11.00		
	Average	12.03	19.13	14.44	33.38	29.86	8.55		
Tributyltin (ng/L)	Spring Flood	20.0	10.0	50.0	<10	10.0	40.0	-	10
	Spring Ebb	<10	<10	<10	20.0	<10	<10		
	Neap Flood	30.0	20.0	40.0	<10	20.0	30.0		
	Neap Ebb	10.0	<10	<10	30.0	<10	<10		
	Average	20.0	15.0	45.0	25.0	15.0	35.0		
Total Phosphorous, TP (mg/L)	Spring Flood	0.057	0.027	0.016	0.026	0.022	0.019	-	Marine inshore: 0.015 (AGI) Marine offshore: 0.010 (AGI)
	Spring Ebb	0.022	0.020	0.057	0.022	0.023	0.029		
	Neap Flood	0.036	0.027	0.038	0.032	0.038	0.055		
	Neap Ebb	0.032	0.027	0.033	0.036	0.036	0.026		
	Average	0.037	0.025	0.036	0.029	0.030	0.032		

Parameter		WQ1A and WQ1B	WQ2	WQ3	WQ4	WQ5	WQ6	NEA Trade Effluent Discharge Limits ¹	Water Quality Criteria for Aquatic Life ²
Site		Back Mangrove Area	Pond 1	Pond 2	Pond 3	Coastal Area Near Project Site	Offshore Area Near Aquaculture Farms		
Orthophosphate as PO ₄ -P (mg/L)	Spring Flood	0.05	0.01	0.01	0.01	0.01	0.02	≤ 1.625 (equivalent to 5 as PO ₄)	Coastal water: ≤ 0.015 (equivalent to 0.045 as PO ₄)
	Spring Ebb	0.019	0.010	0.011	0.009	0.012	0.015		
	Neap Flood	0.035	0.025	0.037	0.028	0.021	0.007		
	Neap Ebb	0.030	0.025	0.030	0.032	0.030	0.006		
	Average	0.034	0.018	0.022	0.020	0.018	0.012		
Total Nitrogen, TN (mg/L)	Spring Flood	1.50	0.50	0.47	0.72	0.73	0.41	-	0.1 (AGI)
	Spring Ebb	0.66	0.60	0.58	0.78	0.55	0.34		
	Neap Flood	0.60	0.64	0.63	0.47	0.60	0.59		
	Neap Ebb	0.62	0.56	0.40	0.59	0.45	0.47		
	Average	0.85	0.58	0.52	0.64	0.58	0.45		
Ammonium as NH ₄ -N (mg/L)	Spring Flood	0.95	0.12	0.29	0.20	0.05	0.06	-	0.07
	Spring Ebb	0.21	0.02	0.03	0.02	0.02	0.05		
	Neap Flood	0.19	0.14	0.13	0.12	0.06	0.01		
	Neap Ebb	0.22	0.07	0.05	0.07	0.04	<0.01		
	Average	0.39	0.08	0.12	0.10	0.04	0.04		
Nitrite as NO ₂ -N (mg/L)	Spring Flood	<0.02	0.046	0.049	0.049	0.044	0.025	-	0.055
	Spring Ebb	0.036	0.042	0.041	0.039	0.044	0.025		
	Neap Flood	<0.02	0.040	0.042	0.032	0.028	<0.02		
	Neap Ebb	<0.02	0.036	0.039	0.041	0.024	<0.02		
	Average	0.036	0.041	0.043	0.040	0.035	0.03		
Nitrate as NO ₃ -N (mg/L)	Spring Flood	<0.005	0.04	0.03	0.04	0.05	0.06	-	0.06
	Spring Ebb	0.04	0.03	0.02	0.02	0.04	0.06		
	Neap Flood	0.0098	0.033	0.034	0.036	0.033	0.01		
	Neap Ebb	0.0069	0.033	0.034	0.036	0.046	0.01		
	Average	0.017	0.033	0.030	0.033	0.041	0.04		
Biochemical Oxygen Demand, BOD ₅ (mg/L)	Spring Flood	1.07	<1	1.12	1.17	1.10	<1	20	4 (USEPA)
	Spring Ebb	1.20	1.23	1.45	1.62	1.11	<1		
	Neap Flood	<1	1.82	<1	1.52	1.63	<1		
	Neap Ebb	1.91	1.40	<1	<1	<1	<1		
	Average	1.39	1.48	1.29	1.44	1.28	<1		
Total Phenol (mg/L)	Spring Flood	<0.025	<0.025	<0.025	<0.025	<0.025	<0.025	-	0.12
	Spring Ebb	<0.025	<0.025	<0.025	<0.025	<0.025	<0.025		
	Neap Flood	<0.025	<0.025	<0.025	<0.025	<0.025	<0.025		
	Neap Ebb	<0.025	<0.025	<0.025	<0.025	<0.025	<0.025		
	Average	<0.025	<0.025	<0.025	<0.025	<0.025	<0.025		
Faecal Coliform (CFU/100ml)	Spring Flood	220.0	94.0	34.0	58.0	70.0	11.0	-	100
	Spring Ebb	540.0	70.0	79.0	170.0	150.0	2.0		
	Neap Flood	20.0	2.0	17.0	2.0	14.0	63.0		
	Neap Ebb	110.0	10.0	120.0	58.0	8.2	6.0		
	Average	222.5	44.0	62.5	72.0	60.6	20.5		
Free Chlorine (µg/L)	Spring Flood	<0.2	<0.2	<0.2	<0.2	<0.2	<0.2	-	-
	Spring Ebb	<0.2	<0.2	<0.2	<0.2	<0.2	<0.2		
	Neap Flood	<0.2	<0.2	<0.2	<0.2	<0.2	<0.2		
	Neap Ebb	<0.2	<0.2	<0.2	<0.2	<0.2	<0.2		
	Average	<0.2	<0.2	<0.2	<0.2	<0.2	<0.2		
Enterococcus (CFU/100ml)	Spring Flood	160	26	94	62	92	4	200 ⁵	35
	Spring Ebb	340	24	22	68	164	4		
	Neap Flood	152	43	48	124	1200	<1		
	Neap Ebb	236	36	136	202	102	<1		
	Average	222	32	75	114	390	4		

Parameter		WQ1A and WQ1B	WQ2	WQ3	WQ4	WQ5	WQ6	NEA Trade Effluent Discharge Limits ¹	Water Quality Criteria for Aquatic Life ²
Site		Back Mangrove Area	Pond 1	Pond 2	Pond 3	Coastal Area Near Project Site	Offshore Area Near Aquaculture Farms		
Lead, Pb (µg/L)	Spring Flood	<0.5	<0.5	<0.5	<0.5	<0.5	<0.5	100	8.5
	Spring Ebb	<0.5	<0.5	<0.5	<0.5	<0.5	<0.5		
	Neap Flood	<0.5	<0.5	<0.5	<0.5	<0.5	<0.5		
	Neap Ebb	<0.5	<0.5	<0.5	<0.5	<0.5	<0.5		
	Average	<0.5	<0.5	<0.5	<0.5	<0.5	<0.5		
Cyanide, CN ⁻ (mg/L)	Spring Flood	<0.005	<0.005	<0.005	<0.005	<0.005	<0.005	-	0.007
	Spring Ebb	<0.005	<0.005	<0.005	<0.005	<0.005	<0.005		
	Neap Flood	<0.005	<0.005	<0.005	<0.005	<0.005	<0.005		
	Neap Ebb	<0.005	<0.005	<0.005	<0.005	<0.005	<0.005		
	Average	<0.005	<0.005	<0.005	<0.005	<0.005	<0.005		
Arsenic, As (µg/L)	Spring Flood	2.84	2.42	2.36	2.34	2.28	2.96	-	120
	Spring Ebb	2.50	1.90	2.16	2.42	2.08	2.92		
	Neap Flood	2.04	2.22	2.32	2.28	2.25	2.36		
	Neap Ebb	2.26	2.02	2.30	2.33	2.18	2.19		
	Average	2.41	2.14	2.28	2.34	2.20	2.61		
Cadmium (µg/L)	Spring Flood	<0.5	<0.5	<0.5	<0.5	<0.5	<0.5	-	10
	Spring Ebb	<0.5	<0.5	<0.5	<0.5	<0.5	<0.5		
	Neap Flood	<0.5	<0.5	<0.5	<0.5	<0.5	<0.5		
	Neap Ebb	<0.5	<0.5	<0.5	<0.5	<0.5	<0.5		
	Average	<0.5	<0.5	<0.5	<0.5	<0.5	<0.5		
Chromium (VI), (µg/L)	Spring Flood	<25	<25	<25	<25	<25	<25	-	50
	Spring Ebb	<25	<25	<25	<25	<25	<25		
	Neap Flood	<25	<25	<25	<25	<25	<25		
	Neap Ebb	<25	<25	<25	<25	<25	<25		
	Average	<25	<25	<25	<25	<25	<25		
Copper, Cu (µg/L)	Spring Flood	<0.5	0.58	0.65	0.62	0.67	1.16	-	8
	Spring Ebb	0.53	0.60	0.60	0.79	0.57	1.07		
	Neap Flood	0.81	0.79	0.74	0.78	0.71	0.76		
	Neap Ebb	<0.5	0.73	0.78	0.88	0.68	0.86		
	Average	0.67	0.68	0.69	0.77	0.66	0.96		
Nickel, Ni (µg/L)	Spring Flood	1.55	1.89	1.92	1.81	1.73	3.22	-	Chronic: 8.2 (USEPA) Acute: 74 (USEPA)
	Spring Ebb	1.66	1.83	2.97	3.53	2.19	2.23		
	Neap Flood	1.34	1.19	1.16	1.37	1.23	1.18		
	Neap Ebb	1.11	1.29	1.38	1.17	1.22	1.27		
	Average	1.41	1.55	1.86	1.97	1.59	1.98		
Zinc, Zn (µg/L)	Spring Flood	1.10	<0.5	<0.5	0.84	<0.5	2.54	-	Chronic: 81 (USEPA) Acute: 90 (USEPA)
	Spring Ebb	1.02	0.76	<0.5	<0.5	<0.5	<0.5		
	Neap Flood	1.50	1.47	1.52	2.12	0.69	<0.5		
	Neap Ebb	2.41	1.09	3.06	<0.5	1.27	<0.5		
	Average	1.51	1.11	2.29	1.48	0.98	2.54		
Mercury, Hg (µg/L)	Spring Flood	<0.1	<0.1	<0.1	<0.1	<0.1	<0.1	-	0.16
	Spring Ebb	<0.1	<0.1	<0.1	<0.1	<0.1	<0.1		
	Neap Flood	<0.1	<0.1	<0.1	<0.1	<0.1	<0.1		
	Neap Ebb	<0.1	<0.1	<0.1	<0.1	<0.1	<0.1		
	Average	<0.1	<0.1	<0.1	<0.1	<0.1	<0.1		
Oil and Grease (Total) (mg/L)	Spring Flood	0.16	<0.1	<0.1	<0.1	<0.1	<0.1	-	0.14
	Spring Ebb	<0.1	<0.1	<0.1	<0.1	<0.1	<0.1		
	Neap Flood	0.22	<0.1	<0.1	<0.1	<0.1	<0.1		
	Neap Ebb	0.12	<0.1	<0.1	<0.1	<0.1	<0.1		
	Average	0.17	<0.1	<0.1	<0.1	<0.1	<0.1		

Parameter	WQ1A and WQ1B	WQ2	WQ3	WQ4	WQ5	WQ6	NEA Trade Effluent Discharge Limits ¹	Water Quality Criteria for Aquatic Life ²
Site	Back Mangrove Area	Pond 1	Pond 2	Pond 3	Coastal Area Near Project Site	Offshore Area Near Aquaculture Farms		

Note:

1. NEA Trade Effluent Discharge Limits are for uncontrolled watercourses
2. The sources of water quality criteria for aquatic life include ASEAN Marine Water Quality Criteria (i.e. for aquatic life and human health) and United States Environmental Protection Agency (USEPA).
3. **Red** values mean data exceeding the NEA Trade Effluent Discharge Limits; **Blue** values mean data exceeding ASEAN Marine Water Quality Criteria; **Orange** values mean data exceeding both limits of ASEAN Marine Water Quality Criteria and NEA guidelines.
4. '<0.5' means lower than 0.5 µg/L, which is the parameter's detection limit; This similarly applies across for other parameters, such that '<X' means lower than X unit, which is the parameter's detection limit.
5. Singapore's Water Quality Guidelines for Recreational Beaches [W-24] requires that the *Enterococcus* count should be less than or equal to 200 counts per 100 millilitres of water at 95% of the time for safe recreational use by the public.

As shown in Figure 7-16, the variations in temperature across the various sampling stations were attributed to each location's site-specific environmental conditions and were below the NEA limit of 45°C for all stations. The average temperature of the open waters at the offshore area near the aquaculture ponds (WQ6) was 30.91°C, which was about 3°C higher than that of the shaded area at the back mangrove area (WQ1A, WQ1B) which was 28.18°C.

Apart from comparing the baseline water quality to NEA limits for trade effluent regulations, since these waterbodies are supporting ecosystems, the baseline water quality results were compared to ASEAN Marine Water Quality Criteria (AMWQC) and other water quality standards that were defined for conditions that support aquatic life, in order to evaluate their competence in supporting aquatic life. pH at the upstream of the back mangrove area (WQ1B) was found to have a low pH value of pH 6.40, which exceeds suitable pH range of AMWQC (i.e. pH 6.5 – pH 9). Given that the sampling location WQ1B had natural earth bank conditions, the low pH may be due to the presence of higher concentrations of humic acid from decomposing forest debris that was flushed down from the surrounding vegetation.

The average dissolved oxygen (DO) at the back mangrove area (WQ1A, WQ1B) was relatively low at 1.91 mg/L, which was below the recommended AMWQC limits of 4 mg/L, implying that the back mangrove area has conditions less favourable for aquatic life. This low DO is consistent with the site observations of the back mangrove area, which was observed to have very slow or near-stagnant flow, which therefore limits the rate of aeration, at the time of survey. On the other hand, all other sampling stations (WQ2 – WQ6) had DO levels higher than 4 mg/L. This is because the Ponds (WQ2, WQ3, WQ4) are well-mixed due to the constant flooding and ebbing of the tides and that the coastal area (WQ5) and offshore areas (WQ6) were also well-mixed from the wave action.

The conductivity of water is strongly dependent on the number of ions available to participate in the conduction process. This parameter is positively correlated to total dissolved solids (TDS), which measures the total amount of organic and inorganics present in the water, and salinity, which measures the amounts of salts dissolved in water. Generally, the conductivity, TDS and salinity at the upstream of back mangrove area (WQ1B) (i.e. 9299 µS/cm, 5657 mg/L and 4.82 PSU) was significantly lower than that of its downstream (WQ1A) (i.e. average of 46,788 µS/cm, 28,751 mg/L and 28.47 PSU), indicating the presence of brackish water at its upstream. This brackish water is likely to be formed due to mixing of the runoff from the terrestrial area with tidal floods. The conductivity, TDS and salinity results at WQ1A were similar to those of other sampling stations (WQ2 to WQ6), implying that the downstream of the back mangrove area was mainly seawater, and is mostly influenced by the flooding and ebbing of the tides.

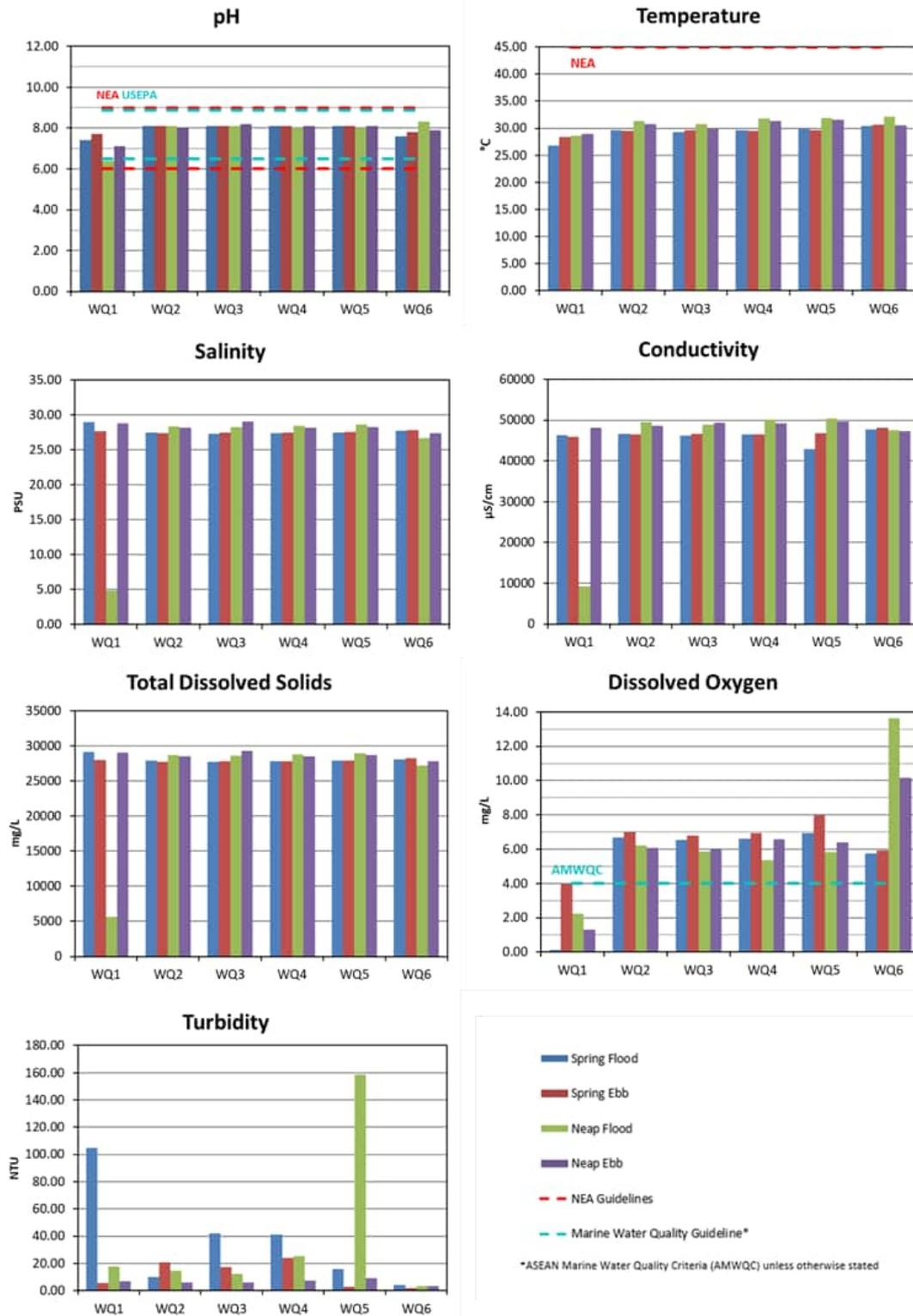

Figure 7-16 Monitoring results of in-situ water quality parameters.

There was exceedance of the total suspended solids (TSS) NEA limits of 50 mg/L at Pond 3 (i.e. WQ4, 69.30 mg/L) and at the coastal area (i.e. WQ5, 59.50 mg/L) during neap-flood and spring-flood conditions, respectively. Furthermore, generally, during both spring and neap tide conditions, the average TSS concentration during flood tides was higher compared to the average TSS concentration during ebb tides (refer to Table 7-16). This suggests that the elevated TSS did not originate from the terrestrial area and was likely due to the flushing of sediments by wave action.

Elevated nutrients levels were observed across all sampling stations. Total phosphorus (TP), orthophosphate (PO₄-P) and total nitrogen (TN) was found to exceed its respective AMWQC limits (i.e. 0.010 mg/L, 0.015 mg/L, 0.1 mg/L) across all six (6) sampling stations, and exceeded the limits for ammonia (NH₄-N) (i.e. 0.07 mg/L) at the back mangrove area and three (3) Ponds (i.e. WQ1, WQ2, WQ3, WQ4). On the other hand, the nitrite (NO₂-N) and nitrate (NO₃-N) concentrations had met the AMWQC criteria. This aligns with previous environmental studies conducted along the Serangoon Harbour [P-76, P-77].

Oil and grease levels were found to exceed the AMWQC limits of 0.14 mg/L at the back mangrove area (WQ1) during spring-flood and neap-flood tides. This suggests that the oil and grease originated from the marine environment, as it occurred during inward-flowing tidal conditions. Apart from the back mangrove area, oil and grease was not observed at other sampling stations (i.e. WQ2, WQ3, WQ4, WQ5, WQ6).

Tributyltin is a class of highly toxic organotin compounds previously used a biocide in anti-fouling paint on ship vessels. With the exception of Pond 3 (i.e. WQ4), tributyltin was found to exceed the AMWQC limits (i.e. 10 ng/L) at most of the water quality stations (i.e. WQ1, WQ2, WQ3, WQ5, WQ6) during both spring-flood and neap-flood tide conditions. This suggests that the pollutant likely originated from the marine environment, which corresponds with its abovementioned usage in ship paints. Furthermore, the navigation channel near the southern coast of Pulau Ubin (i.e. Serangoon Harbour), which is located near the Project Site, is heavily utilised by vessels daily.

Heavy metals, such as arsenic, cadmium, chromium (VI), copper, lead, mercury, nickel and zinc, were found to be well below their respective water quality criteria limits, across all sampling locations. Furthermore, other chemicals such as total phenol, free chlorine and cyanide were found to below their respective detection limits across all six sampling stations. Biochemical oxygen demand (BOD₅), which indicates the presence of biodegradable organic compounds, was also found to be well below the USEPA threshold criteria at all sampling stations.

Biological contaminants, such as *enterococcus* and faecal coliform counts, exceeded the AMWQC for human health protection at the back mangrove area (WQ1), Pond 1, Pond 2, Pond 3 and the coastal areas, indicating that some faecal contamination might have been from the terrestrial environment, possibly from animal faeces. This may be plausible since animal droppings were observed along the bunds during the time of survey. The offshore sampling point (WQ6) near the aquaculture farm recorded relatively lower levels of biological contaminants than other sampling locations. This exceedance of the water quality criteria for human health protection (AMWQC) at these stations may imply that there may be some human health risks should primary contact activities³ be conducted within the waters.

In conclusion, the baseline water quality of the Project Site and its vicinity is relatively favourable for aquatic life, especially since key water quality parameters such as heavy metals were found to be well below the threshold limit. In-situ parameters, such as pH and DO, were found to exceed the AMWQC at the back mangrove area, but this was attributed to its relatively stagnant flow conditions and aquatic fauna was not observed onsite. Although elevated nutrient levels were detected in the Project Site and its vicinity, this observation is aligned with previous studies conducted at Serangoon Harbour which similarly showed elevated nutrient levels [P-76, P-77]. Chemical pollutants that exceeded the guideline limits, such as oil and grease and tributyltin, likely originated from the marine environment, while biological pollutants, such as *enterococcus* and faecal coliform, were likely from the terrestrial environment. This may imply that the baseline water quality may pose human health risks if primary contact activities be conducted within the waters.

³ Primary contact activities include those where: (1) the whole body or the face and trunk are frequently immersed; (2) it is likely that some water will be swallowed. Examples include swimming, wakeboarding, diving, windsurfing, water immersion training (e.g. capsizing training for kayaking and canoeing) [W-26].

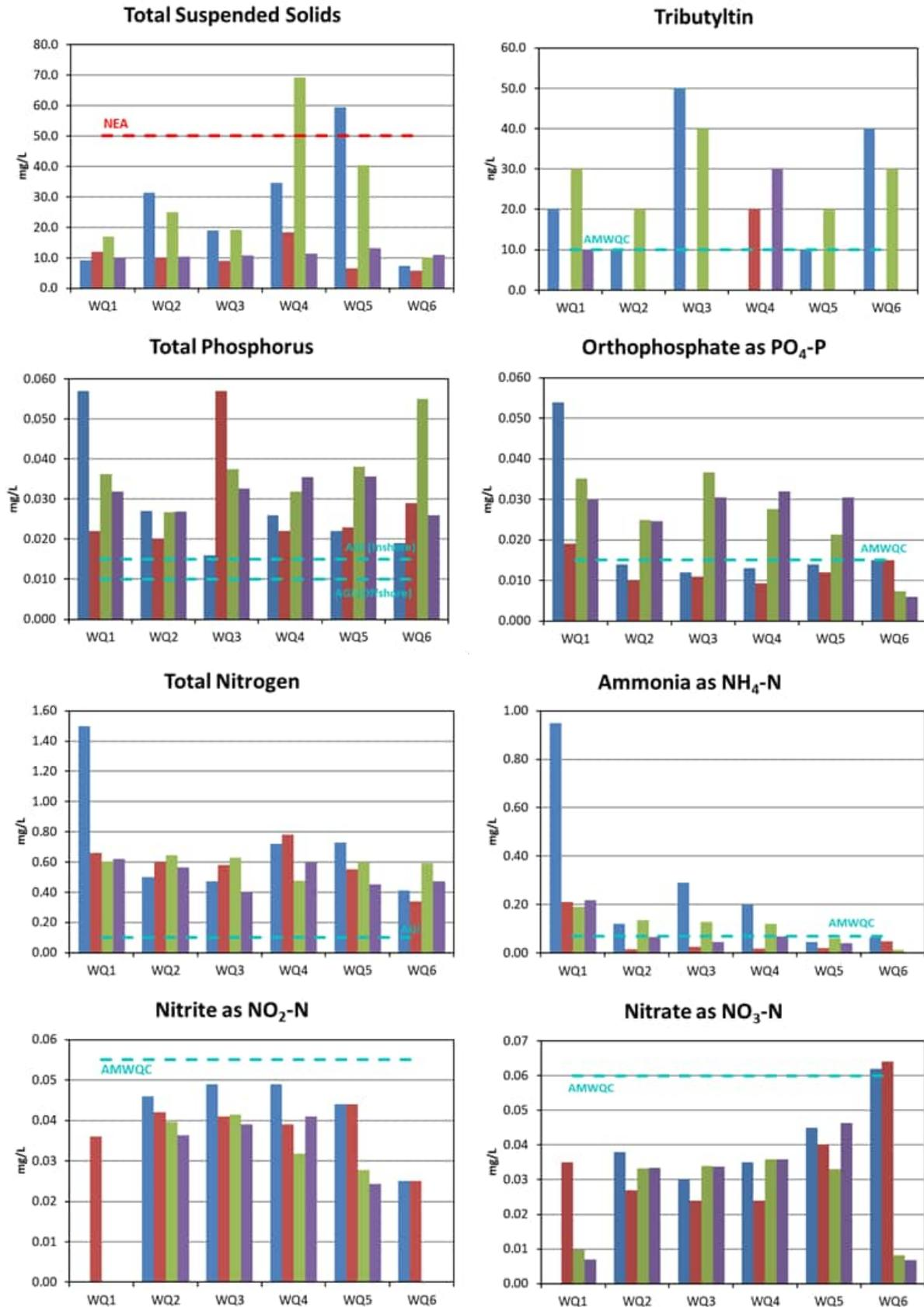

Figure 7-17 Monitoring results of ex-situ water quality parameters (1 of 3). Note: missing bars indicates that the concentration of the measured parameter is below the detection limit.

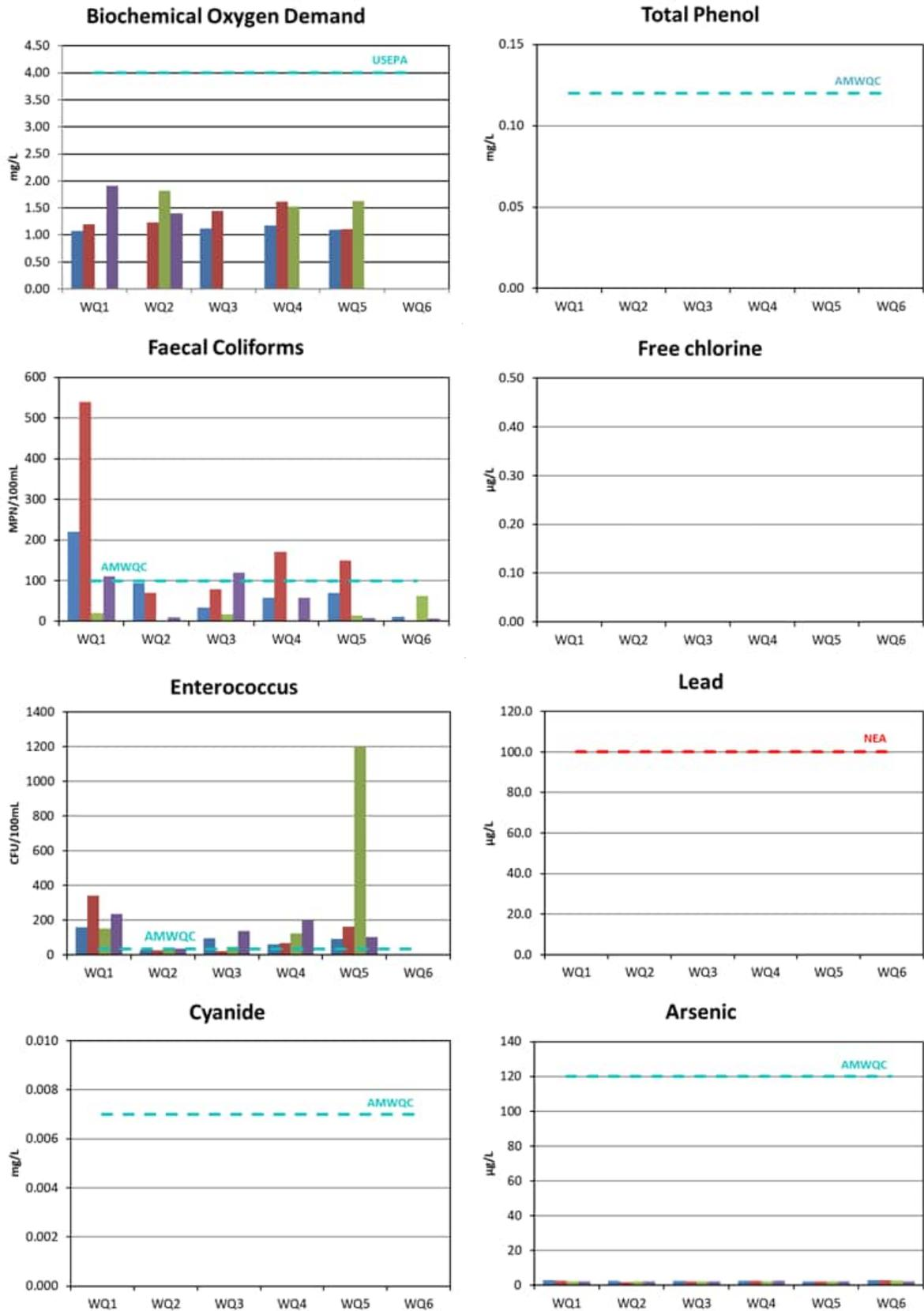

Figure 7-18 Monitoring results of ex-situ water quality parameters (2 of 3). Note: missing bars indicates that the concentration of the measured parameter is below the detection limit.

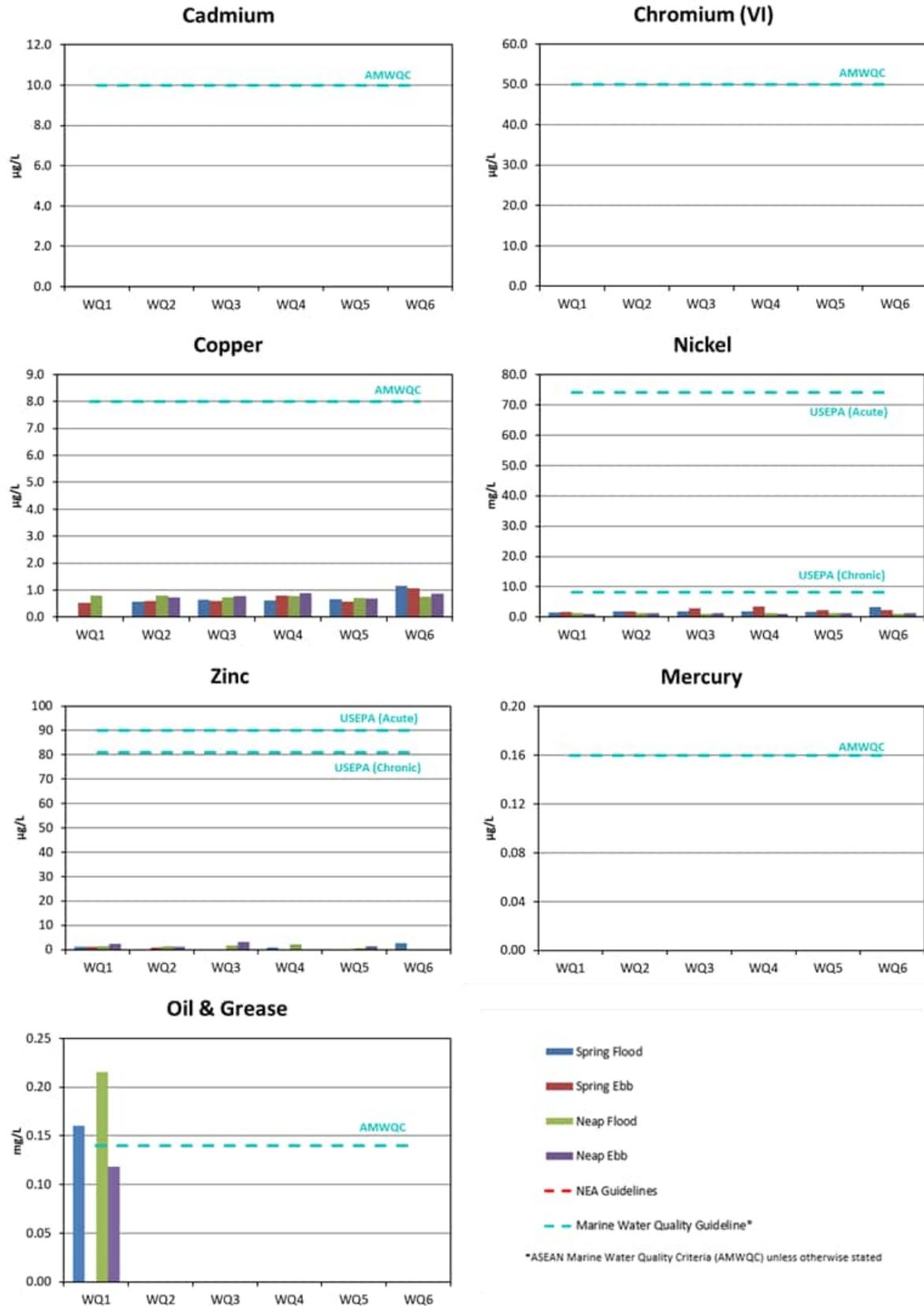

Figure 7-19 Monitoring results of ex-situ water quality parameters (3 of 3). Note: missing bars indicates that the concentration of the measured parameter is below the detection limit.

7.4.5 Underwater Noise

Baseline underwater noise monitoring was conducted at one (1) offshore monitoring location along Serangoon Harbour to assess the sources and characteristics of the ambient underwater soundscape in the vicinity of the Project Site. The first monitoring event was conducted from 13th December 2022 to 15th December 2022, while the second monitoring event was conducted from 4th January 2023 to 6th January 2023.

Spectrograms of the 1/3 octave band-analysis of the first and second monitoring events are depicted in Figure 7-20 and Figure 7-21, respectively. The monitored acoustic spectra is presented as a time series with the time shown along the horizontal axis, with the colour scale on the right vertical axis indicating the sound pressure levels (SPL), and the left vertical axis for the frequency band.

Intense noise levels at frequency of around 1000 Hz, ranging from 105 – 125 dB, with tidal periodicity (i.e. denoted by 'A' in Figure 7-20 and Figure 7-21) was observed due to turbulence caused by tidal flow. The signals recorded during the daytime are likely to be due to the vessel traffic along Serangoon Harbour. Low-frequency ambient noise (20 – 500 Hz) is associated with shipping noise, which is generated by their propulsion system [P-78]. Typically, ships contribute to the low-frequency ambient noise (10 – 100 Hz) [P-79]. Smaller boats, such as those used to ferry visitors from Changi Ferry Terminal to Pulau Ubin Jetty, produce sounds that ranges between 1 – 5 kHz and at moderate noise source levels (i.e. 150 – 180 dB re 1 μ Pa at 1 m from source) [P-78]. As shown by segments labelled 'B' in Figure 7-20 and Figure 7-21, there is a decrease in low-frequency ambient noise, and which corresponds to a decrease in vessel traffic during the night-time. The second monitoring event (Figure 7-21) had higher vessel traffic, as indicated by continuous vertical bands rather than vertical bands with gaps seen in the first monitoring event (Figure 7-20).

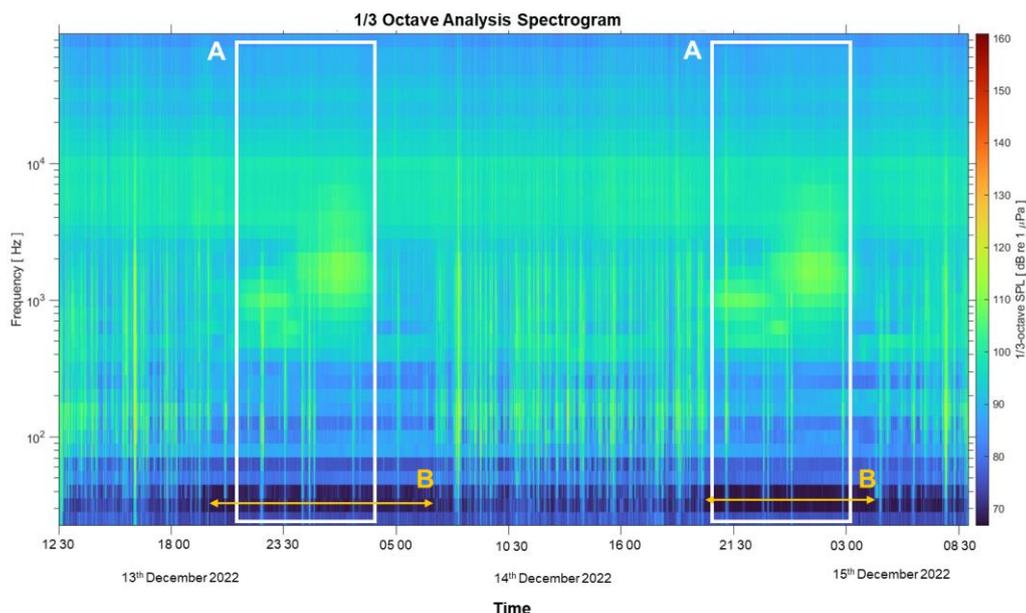

Figure 7-20 Spectrogram of first monitoring event. Segment labelled 'A' highlights the acoustic signature of turbulent pressure fluctuations of currents. Segment labelled 'B' indicates the period with decreased vessel traffic. The horizontal axis indicates time, left vertical axis indicates the frequency and the right vertical axis shows a colour scale of the 1/3-octave sound pressure level (SPL).

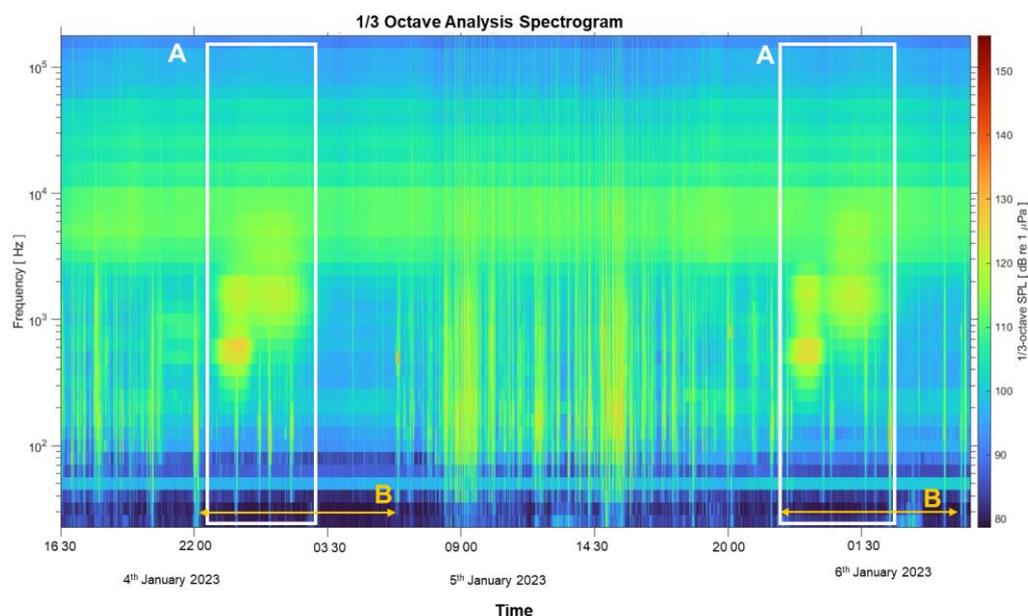

Figure 7-21 Spectrogram of second monitoring event. Segment labelled 'A' highlights the acoustic signature of turbulent pressure fluctuations of currents. Segment labelled 'B' indicates the period with decreased vessel traffic. The horizontal axis indicates time, left vertical axis indicates the frequency and the right vertical axis shows a colour scale of the 1/3-octave sound pressure level (SPL).

Figure 7-22 and Figure 7-23 indicate the percentile spectral levels of ambient noise for the first and second monitoring event respectively. In general, spectral levels increase almost linearly with increasing frequency from 100 Hz to 10 kHz, which is a common characteristic of ambient noise spectral data. There is greater variation in sound pressure levels in the lower frequency spectrum (i.e. 10 Hz to 3 kHz) than the higher frequency spectrum (i.e. >3 kHz) of the ambient noise environment.

The ambient background noise levels at Serangoon Harbour which are within the hearing sensitivities of fishes (i.e. 30 Hz to 5 kHz [P-80]) range between 70 – 110 dB (5th to 95th percentiles). Generally, the baseline ambient underwater noise environment is well below the threshold value of 158 dB re 1 µPa of impairment to fishes (refer to Table 7-8). Background levels within the hearing sensitivities of dugongs (i.e. 1 kHz to 18 kHz [P-81]) – known to be found along the East Johor Strait (refer to Appendix E) – ranges between 90 to 110 dB (5th to 95th percentiles). Currently, little is known about the threshold for detectable auditory responses by dugongs. For cetaceans like Irrawaddy dolphin (*Orcaella brevirostris*), Indo-pacific humpbacked dolphin (*Sousa chinensis*), Indo-pacific bottlenose dolphin (*Tursiops aduncus*) – refer to Appendix E for expected species list near the site – the baseline sound pressure level is within 90 – 105 dB (5th to 95th percentiles) of their hearing range of 150 Hz to 160 kHz [P-82], which is well below the onset threshold of 120 dB RMS for continuous noises (refer to Table 7-6).

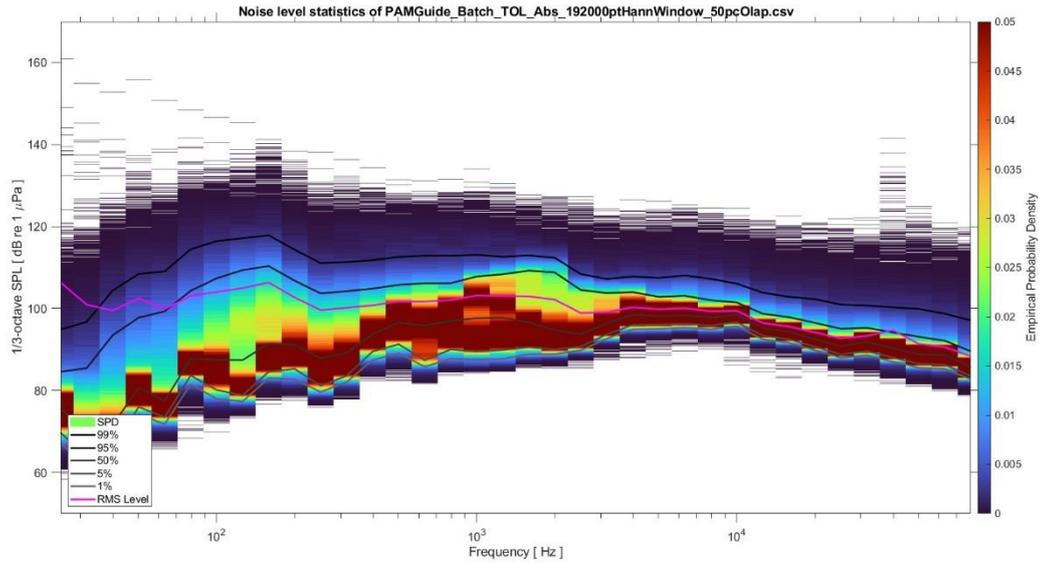

Figure 7-22 Density probability spectrogram for the first monitoring period at the underwater noise monitoring location. The 1st, 5th, 25th, 50th, 95th and 99th percentiles and RMS levels were plotted. The 5th percentile is the minimum, 50th percentile is the median and 95th the maximum. The colour scale represents the spectral probability density (SPD).

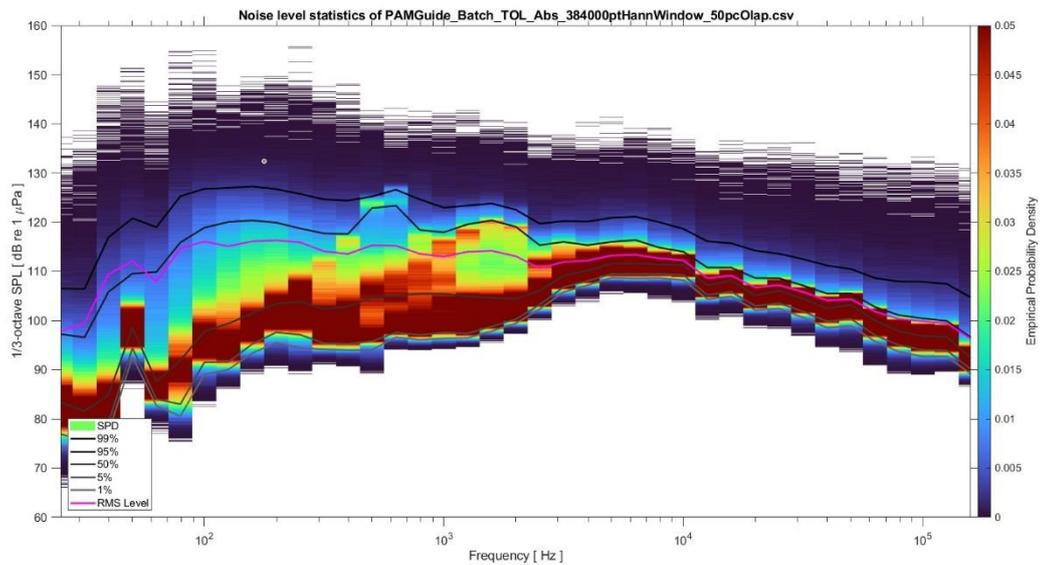

Figure 7-23 Density probability spectrogram for the first monitoring period at the underwater noise monitoring location. The 1st, 5th, 25th, 50th, 95th and 99th percentiles and RMS levels are plotted. The 5th percentile is the minimum, 50th percentile is the median and 95th the maximum. The colour scale represents the spectral probability density (SPD).

7.5 Identification of Marine Water Sensitive Receptor

Receptor screening for marine water was conducted for the Assessment Area for both construction and operational phases. The criteria detailed in Table 5-2 was used to determine the sensitivity of the marine water quality receptors presented in Table 7-17 and Table 7-18.

7.5.1 Construction Phase

During construction phase, the human, ecology and water-dependent socio-economic receptors are identified and classified based on sensitivity classification (Table 5-2) as shown in Table 7-17.

Table 7-17 Classification of marine water sensitive receptors identified within the Assessment Area for construction phase

Sensitive Receptor	Environmental Parameter	Receptor Description	Receptor Classification	Impact Assessment Type
Human Receptors				
On-site construction workers	<ul style="list-style-type: none"> Marine Water Quality 	<ul style="list-style-type: none"> Construction workers will not use marine water within Project Site and its vicinity for any beneficial purpose (i.e. drinking and industrial purposes, irrigation) Construction workers may come in direct contact with marine water during various pre-construction and construction activities (e.g. washing, cleaning, transporting and dumping filling material, etc.) Baseline marine water quality data (refers to Section 7.4.3.2.2) indicates that the water quality poses human health risk, as the indicator indicates that the coastal waters is not suitable for primary contact activities. 	Priority 2	Assessed in qualitative impact assessment (refer to Section 7.7.1.1).
Permanent off-site residents and visitors in the vicinity of the Project Site and its vicinity	<ul style="list-style-type: none"> Marine Water Quality 	<ul style="list-style-type: none"> Permanent off-site residents will not use marine water within Project Site and its vicinity for any beneficial purpose (i.e. drinking and industrial purposes, irrigation) Off-site permanent residents and visitors may be exposed to marine water from the Project Site and its vicinity indirectly, by coming in contact (e.g. dermal contact, inhalation of water particles) with downstream waterbody (i.e. sea) Off-site permanent residents and visitors may visual the sediment plume impact as suspended solid in the vicinity of Project Site Baseline marine water quality data (refers to Section 7.4.3.2.2) indicates that the water quality poses human health risk, as the indicator indicates that the coastal waters is not suitable for primary contact activities. 	Priority 2	Assessed in qualitative and quantitative impact assessment (refer to Section 7.7.1).
Ecological Receptors				

Sensitive Receptor	Environmental Parameter	Receptor Description	Receptor Classification	Impact Assessment Type
Habitats and biocenosis in the vicinity of Project Site	<ul style="list-style-type: none"> Marine Water Quality Underwater Noise 	<ul style="list-style-type: none"> Based on the biodiversity baseline study findings (Section 6.3 of this Report), habitats and biocenosis in the vicinity of Project Site are identified to be of high ecological value. Habitats and biocenosis in the vicinity of Project Site are highly dependent of the quality of marine water and would most likely be disturbed due to the changes in marine water quality Possible presence of marine fauna that relies on underwater acoustics for survival (e.g. for sensing of surroundings, protection against predation, use for courtship and/or mating) in the coastal waters in the vicinity of the Project Site. 	Priority 1	Assessed in qualitative impact assessment (refer to Section 7.7.1).
Seagrass meadow (including the Chek Jawa)	<ul style="list-style-type: none"> Marine Water Quality (sediment plume) 	<ul style="list-style-type: none"> Based on the biodiversity baseline study findings (Section 6.3 of this Report), habitats and biocenosis of marine areas are identified to be of high ecological value. Seagrass presented in the east of Pulau Ubin (including Chek Jawa) are highly dependent of the quality of marine water and would most likely be disturbed by changes in marine water quality (especially sediment plume) 	Priority 1	Assessed in quantitative impact assessment (refer to Section 7.7.1).
Mangrove along the southern shoreline of Pulau Ubin	<ul style="list-style-type: none"> Marine Water Quality (sediment plume) 	<ul style="list-style-type: none"> Based on the biodiversity baseline study findings (Section 6.3 of this Report), habitats and biocenosis of marine areas are identified to be of high ecological value. The mangrove presented along the shoreline of Pulau Ubin and main Singapore island are dependent of the sedimentation rate induced by sediment plume. 	Priority 1	Assessed in quantitative impact assessment (refer to Section 7.7.1).
Water Dependent Socio-Economic Receptors				
Aquaculture farms	<ul style="list-style-type: none"> Marine Water Quality Underwater Noise 	<ul style="list-style-type: none"> Aquaculture farms in the vicinity of Project Site are highly dependent of the quality of marine water and would most likely be disturbed due to the changes in Marine water quality Presence of fishes that relies on underwater acoustics for survival (e.g. for sensing of surroundings, protection against predation, use for courtship and/or mating) and unable to move away from the source of the noise (i.e. fish farms). 	Priority 1	Assessed in qualitative and quantitative impact assessment (refer to Section 7.7.1).
International Boundary (IB) of	<ul style="list-style-type: none"> Marine Water Quality 	<ul style="list-style-type: none"> Maritime boundary between the countries of Singapore and Malaysia. 	Priority 1	Assessed in quantitative impact

Sensitive Receptor	Environmental Parameter	Receptor Description	Receptor Classification	Impact Assessment Type
Singapore and Malaysia		<ul style="list-style-type: none"> Possible to have transboundary impact, which disturbed by changes in marine water quality (including sediment plume) from the proposed development. 		assessment (refer to Section 7.7.1).

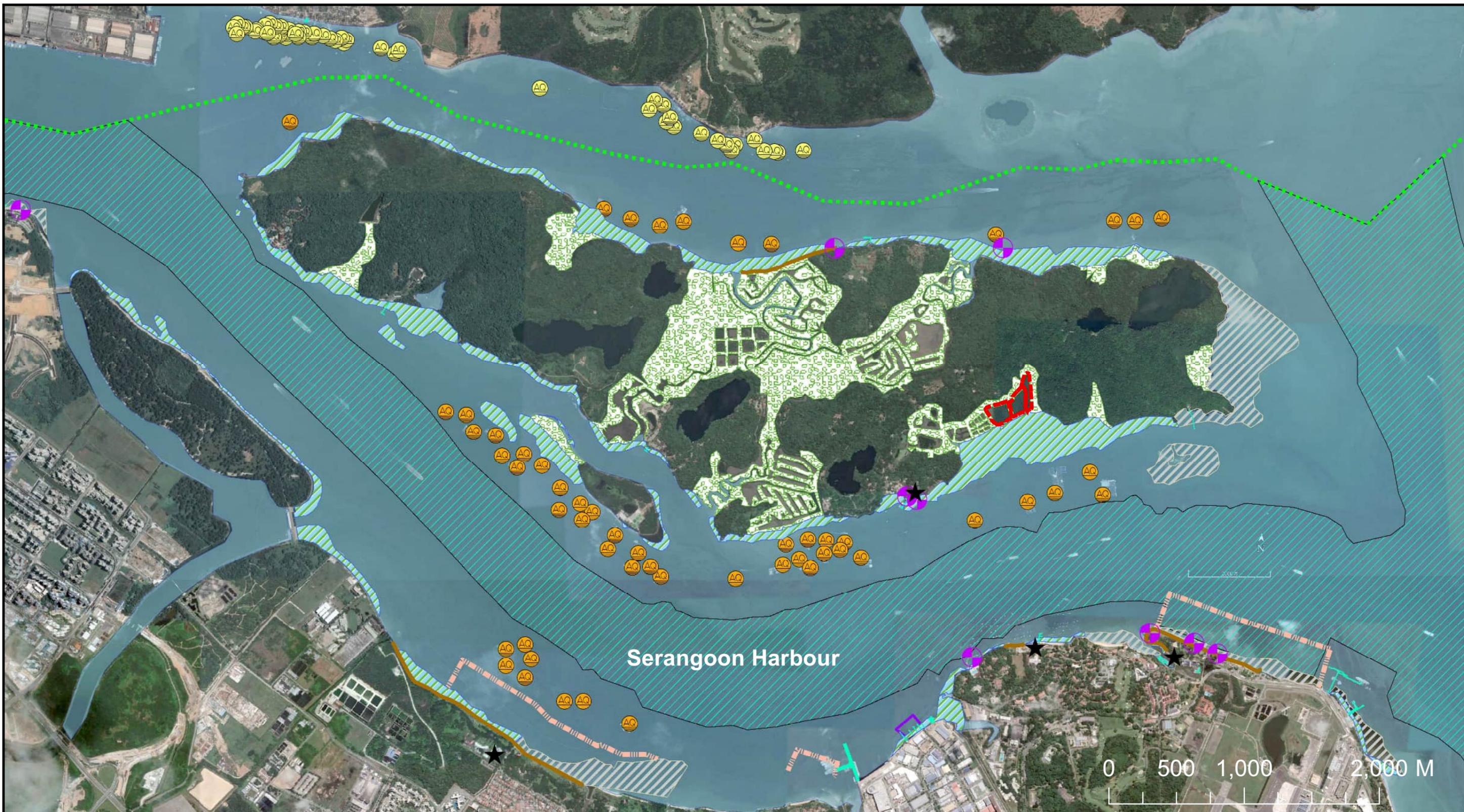

Legend

- Sungai Durian Ponds Project Site
- International Border (Singapore - Malaysia)
- ★ Water Sports Facilities
- Port Boundaries
- Recreational Fishing
- Jetski Designated Areas
- Mangroves
- Recreational Beach
- receptors_navigation_V2_20230801
- Jetties, Wharves and Pontoons
- Aquaculture (Singapore)
- Aquaculture (Malaysia)
- Other Intertidal Habitats
- Intertidal Habitats with Seagrass

Rev.	Date	By	Description	Chk'd	App'd
-	AUG 2022	LAL	EIA Report	NHT	JAG

Qualified Person Endorsement :
NA

NParks Endorsement : NA

Consultant : **AECOM**

Project Title :
**CONTRACT NPARKS/N/39/2017
CONSULTANCY SERVICES FOR SHORELINE
WORKS IN PULAU UBIN
(MANGROVE RESTORATION OF
SUNGEI DURIAN PONDS)**

Designed LAL	Checked NHT	Approved JAG
Drawn LAL	Date AUG 2022	

Client:

Figure Title :
**Potential sensitive receptor locations
within the Study Area
during construction phase**

Figure No. : 7-24	Rev. -	Sheet 1 of 1
CAD File Name : NA		

7.5.2 Operational Phase

During operational phase, the human, ecology and water-dependent socio-economic receptors are identified and classified based on sensitivity classification (Table 5-2) as shown in Table 7-18.

Table 7-18 Classification of marine water sensitive receptors identified within the Assessment Area for operational phase

Sensitive Receptor	Environmental Parameter	Receptor Description	Receptor Classification	Impact Assessment Type
Human Receptors				
Visitors and permanent residents in the vicinity of the proposed development	<ul style="list-style-type: none"> Marine Water Quality 	<ul style="list-style-type: none"> Off-site permanent residents and visitors may be exposed to marine water from the Project Site and its vicinity indirectly, by coming in contact (e.g. dermal contact, inhalation of water particles) with downstream waterbody (i.e. sea) 	Priority 2	Assessed in qualitative impact assessment (refer to Section 7.7.2).
Ecological Receptors				
Habitats and biocenosis in the vicinity of Project Site	<ul style="list-style-type: none"> Marine Water Quality Morphology 	<ul style="list-style-type: none"> Based on the biodiversity baseline study findings (Section 6.3 of this Report), habitats and biocenosis in the vicinity of Project Site are identified to be of high ecological value. Habitats and biocenosis in the vicinity of Project Site are highly dependent of the quality of marine water and would most likely be disturbed due to the changes in Marine water quality Habitats and biocenosis in the vicinity of Project Site (especially at the shoreline areas) are highly dependent on the morphology (i.e. shoreline sedimentation or erosion profile) changes. 	Priority 1	Assessed in qualitative and quantitative impact assessment (refer to Section 7.7.2).
Water-Dependent Socio-Economic Receptors				
Navigation channel near the southern coast of Pulau Ubin (i.e. Serangoon Harbour)	<ul style="list-style-type: none"> Hydrodynamics 	<ul style="list-style-type: none"> The navigation channel could likely be disturbed by changes in hydrodynamics from the proposed development. 	Priority 2	Assessed in quantitative impact assessment (refer to Section 7.7.2).
International Boundary (IB) of Singapore and Malaysia	<ul style="list-style-type: none"> Marine Water Quality Hydrodynamics 	<ul style="list-style-type: none"> Maritime boundary between the countries of Singapore and Malaysia. Possible to have transboundary impact, which disturbed by changes in hydrodynamics and marine water quality from the proposed development. 	Priority 1	Assessed in qualitative and quantitative impact assessment (refer to Section 7.7.2).

7.6 Minimum Controls

This section proposes minimum controls, or standard practices, commonly implemented in Singapore for similar construction and operational activities, which have been assumed to be implemented for the purposes of impact assessment.

7.6.1 Construction Phase

Table 7-19 has a non-exhaustive list of minimum controls for each potential impact identified in Section 7.3.1 for construction phase.

Table 7-19 Minimum controls during the construction phase applicable to marine water quality impact assessment

Potential Source of Impacts	Environmental Parameter Potentially Affected	Minimum Control
<p>Solid & Toxic Wastes Generation</p> <p>(During earthworks, pond filling, storage and transportation of filling material transportation, storage and disposal of solid wastes)</p>	Marine Water Quality	<ul style="list-style-type: none"> • Development of a Standard Operation Procedure (SOP) for safe handling, transfer, storage and disposal of solid waste; • Effective ECM and monitoring implemented as required in the Code of Practice on Surface Water Drainage to ensure that discharge into the stormwater drainage system does not contain TSS in concentrations greater than the prescribed limits under the Sewerage and Drainage (Surface Water Drainage) Regulations; • ECM measures include but are not limited to minimisation of formation of bare soil, use of biodegradable erosion control blankets for the coverage of all bare/erodible surfaces, slope stability, concrete cut-off drains, silt fences/traps along the perimeter cut-off drain, turbidity curtains for works adjacent to waterbodies, etc.; • Implementation of CCTV including SIDS at the public drain to monitor the surface runoff discharges from the sites as per the Public Utilities Board of Singapore's (PUB) circular on Preventing Muddy Waters from the Construction Sites (October 2015); • Protection of stockpiles with biodegradable erosion control blanket coverage and proper scheduling of the demolition and earthworks to reduce the quantity of stockpiles to be stored onsite; • Provision of side flaps on barges and pontoons when transporting fill material to site via sea to prevent spills during transportation. • Provision of enclosed monkey-proof bins and waste disposal facilities cleared up as often as necessary to prevent build-up. Housekeeping checks will be carried out once a day to ensure all litter is cleared from site; • Hazardous substances and toxic wastes should be stored on hard stand, under shelter with a kerb around the storage area; • All wastes will be disposed only in the designated waste disposal facilities and appropriately separated, i.e. by trained workers to properly sort and label the different types of waste (reusable and recyclable waste, toxic and non-toxic waste, etc.); and • Appropriate disposal of any waste listed in the Environmental Public Health (General Waste Collection) Regulations by licensed waste operator/collector.

Potential Source of Impacts	Environmental Parameter Potentially Affected	Minimum Control
<p>Liquid Effluent Generation and Stormwater Runoff</p> <p>(Construction wastewater and stormwater runoff resulting from site clearance, storage, etc.)</p>	<p>Marine Water Quality</p>	<p>Construction wastewater resulting from construction site:</p> <ul style="list-style-type: none"> • A full inventory of all anticipated wastewater streams and volumes should be finalised before the onset of the construction works; • No unmanaged discharge of wastewater stream permitted; • Reduce, reuse, and recycle hierarchy principle to be applied to wastewater on-site; • Regular audits on environmental management procedures will be carried out on-site; • No hazardous liquids to be sent to the detention pond/tank (if any); • Hazardous wastewater (if any), such as oily water, thinners, solvents, or paints should be stored on hard stand, under shelter with a kerb around the storage area. The wastewater should be removed for treatment and disposal off-site by an approved Waste Management Contractor. Hazardous liquids to be handled as Hazardous Waste; • Containment pond/kerbs will be of impervious material and be designed with sufficient capacity to hold volumes of wastewater produced on-site and potential fire-fighting wastewater. Contractor will seek for comment and approval from relevant authorities (e.g. SCDF and NEA) on the treated wastewater to be used for firefighting purpose; • ECM tanks/ponds will be designed in sufficient capacity to hold the turbid stormwater prior to treatment at the ECM facility; • Temporary storage volumes should be provided for overflow situations. Temporary storage with sufficient capacity will capture any expected additional volumes to ensure untreated wastewater is not released to marine water unless it complies with Singapore NEA Guidelines on trade effluent discharge concentrations; • A responsible person (e.g. ECO) to be assigned to oversee the efficient operation of the containment pond/kerbs where 'Good Housekeeping' practices would be adhered to. Also, the area would be carefully managed to avoid spills, leaks, and odour issues, with the containment pond/kerbs checked at least daily to ensure proper functionality; • Daily record volume of wastewater, as well as volumes of sludge and other produced wastes; • Contractor will need to seek approval from relevant authorities (i.e. PUB & NEA) as per PUB Sewerage and Drainage (Trade Effluent) Regulations if the wastewater will be disposed to public sewer or NEA's Trade Effluent Discharge Limits to controlled watercourse if the treated trade effluent will be disposed to surface watercourses. If such discharges are not approved, the trade effluent will be stored, treated or recycled on site and finally disposed off-site; • The discharge of oil or oily mixtures from the construction site is prohibit. • The containment pond/kerbs, as well as wastewater generating areas on-site, to be equipped with spill clean-up kits;

Potential Source of Impacts	Environmental Parameter Potentially Affected	Minimum Control
		<ul style="list-style-type: none"> • Adequate drainage, cut-off drains sump pit, road kerb, piping and toe wall will be designed for channelling of construction process wastewater (e.g. wash water, etc.) and stormwater runoff separately through detailed design for capture and treatment in the containment pond/kerbs. Where applicable (e.g. in the vicinity of liquid storage or refuelling areas), this infrastructure will include oil-water separators to capture inadvertent spills or leaked oils or greases; • Implement a construction EMMP and ensure full preparation of associated plans and procedures including the following: <ul style="list-style-type: none"> • EMMP to include SOPs, an Emergency Response Plan (ERP), an inventory of wastewater streams, training of staff as well as an inspection, maintenance and audit schedule; and • Full development of EMMP Wastewater Management Procedures to include dedicated management and monitoring procedures that covers all eventualities related to the proper operation of the containment pond/kerbs, or any other wastewater discharge location/equipment. • Regular and dedicated procedures for the inspection and maintenance of wastewater (i.e. trade effluent) collection, storage, and treatment infrastructure, such as pipes, oil water separators, silt screens, etc.; • Regular and dedicated procedures for the management of stormwater collection, settling, testing and eventual discharge of 'clean' water to marine water. This should also include associated measures required to prevent high sediment concentration stormwater drainage to marine water; and • A training programme for all on-site workers, including sub-contractors, in relation to their obligations for ensuring proper water quality management; <p>Storage and disposal of domestic liquid wastes:</p> <ul style="list-style-type: none"> • Provision of portable toilets and on-site septic tank; • Regular cleaning of the portable toilets (if any) and clearing of sanitary waste; • Appropriate location of toilet facilities away from any nearby watercourses; • Inspections and audits to ascertain the hygienic conditions onsite; • The toilet facilities will be placed at least 30 m away from any nearby watercourse; • Training of workers on the best practices to contribute in environmental protection; and • Appropriate disposal of any waste listed in the Environmental Public Health (General Waste Collection) Regulations by licensed waste operator/collector regardless the wastes to be disposed off-site or discharged to public sewer.

Potential Source of Impacts	Environmental Parameter Potentially Affected	Minimum Control
		<p>Stormwater Runoff Generation:</p> <p><u>Stormwater Quality:</u></p> <ul style="list-style-type: none"> • ECM measures include but are not limited to minimisation of formation of bare soil, use of biodegradable erosion control blankets for the coverage of all bare/erodible surfaces, concrete cut-off drains, silt fences/traps along the perimeter cut-off drain, turbidity curtains for works adjacent to marine water; • Adequate drainage, piping and/or channelling of stormwater runoff to be assured through detailed design for capture and treatment at ECM tanks/ponds before discharge into marine water; • Regular and dedicated procedures for the inspection and maintenance of stormwater collection, storage, and treatment infrastructure, such as pipes, oil water separation, silt screens, etc.; and • Regular and dedicated procedures for the management of stormwater collection, settling, testing and eventual discharge of 'clean' water to marine water. This should also include associated measures required to prevent high sediment concentration stormwater drainage to marine water. <p><u>Hydrology:</u></p> <ul style="list-style-type: none"> • Runoff within, upstream of, and adjacent to the worksite will be effectively drained away without causing flooding in the vicinity; • Potential increase of peak-flow due to the change in the land use at the worksite can be mitigated by providing detention tanks/ponds within the Project Site. Detention tanks/ponds can capture stormwater during heavy storm events to reduce the peak runoff. • Geotechnical aspect of site's slope stability (such as Earth Retaining and Stabilising structures (ERSS)) to be included in detailed design engineering for the construction stage; and • The design engineers for detailed design may need to ensure that Earth Retaining Stabilisation structures (ERSS) are proposed when the site is cleared and excavated. Concurrently the ECO must ensure that these measures are implemented in the construction phase, as cutting of slopes may result in slope instability.

Potential Source of Impacts	Environmental Parameter Potentially Affected	Minimum Control
<p>Improper Management of Chemical Substances</p> <p>(Use, storage and disposal of chemical substances; refuelling activities; accidental vessel collision)</p>	Marine Water Quality	<ul style="list-style-type: none"> • Development of SOP for safe handling, transfer and storage of toxic waste; housekeeping checks once a day to ensure all toxic waste is cleared from site; • Appropriate tests to ascertain the presence/absence of contamination of the excavated earth and sand; • Appropriate fully sheltered storage area with storage volume to be 110% of the largest volume of chemical substances to be stored (kerb up and enclosed on at least 3 sides, covered and with adequate ventilation); • Appropriate construction material for toxic waste storage containers with leak detection tests conducted periodically; • Provision of secondary containment for all toxic waste stored in bulk as per the requirements in the COPPC/SS593; • Preparation of an emergency response plan, training of the emergency response team (ERT) to be competent in the response mechanism and provision of response kits for any spillages; • Consignment notification/tracking system and transport emergency response plan for transport of toxic waste; • Appropriate disposal of toxic waste as per required in the Environmental Public Health (Toxic Industrial Waste) Regulations by licensed waste operator/collector. • Vessels to be equipped with spill kits and crew to receive proper training on their use; and • Contractor to establish an Emergency Response Plan (ERP) to manage a collision situation, and establish the necessary protocols and procedures.
<p>Underwater Noise Generation</p> <p>(During earthworks, pond filling, storage and transportation of filling material transportation)</p>	Underwater Noise	Currently there are no standard practices mandated for underwater noise.

7.6.2 Operational Phase

Table 7-20 has a non-exhaustive list of minimum controls for each potential impact identified in Section 7.5.2 for operational phase.

Table 7-20 Minimum controls during the operational phase applicable for marine water quality impact assessment

Potential Source of Impact	Environmental Parameter Potentially Affected	Minimum Control
Improper management of liquid and solid wastes	Marine Water Quality	<ul style="list-style-type: none"> • To prepare sufficient monkey-proof disposal bins surrounding of the Project to avoid improper disposal of waste; • To conduct regular inspection on wastes' storage system of the Project;

Potential Source of Impact	Environmental Parameter Potentially Affected	Minimum Control
		<ul style="list-style-type: none"> To monitor the proposed waterbodies and its surroundings with CCTV surveillance regularly to ensure no contamination occurred; To develop an emergency response plan and conduct adequate training to maintenance workers to cope the accidental water contamination; and Raising awareness of various stakeholders with community/stakeholder engagement (e.g. signage boards, warning signs, etc.)
Permanent land use change (changes in bathymetry in pond area)	Marine Hydrodynamic and Morphological patterns	No minimum controls are required by any relevant regulatory framework, international standards and guidelines. Depending on the final impact (either positive or significant negative impact), mitigation measures will be proposed if applicable.

7.7 Prediction and Evaluation of Marine Water Impact

7.7.1 Construction Phase

7.7.1.1 Marine Water Quality Impact Assessment

During the construction phase, direct discharge of wastewater into the open sea is strictly not allowed as there are ecologically sensitive habitats (e.g. intertidal habitats, sea grass at Chek Jawa Wetlands, etc) in the vicinity of the Project Site (refer to Section 7.5.1). However, potential marine water quality impacts may still arise indirectly from solid and toxic waste generation, liquid effluent and stormwater run-off generation, improper management of chemical substances, suspended sediment concentration and other elevated contaminants leaking from seabed sediment due to construction activities. Contamination in marine water quality might further pose socio-economic impact on surrounding aquaculture farms, recreational fishing activities, etc, as identified in Section 7. The sources of impacts will be assessed qualitatively using the risk matrix method as presented in Section 5.4. It should be noted that while the baseline water quality had high biological pollutant concentrations (i.e. *enterococcus*, faecal coliform), the construction works and other recreational activities conducted within the Site are not considered primary contact activities, and therefore the baseline water quality is unlikely to pose human health risks to human receptors such as on-site construction workers and nearby permanent off-site residents and visitors.

7.7.1.1.1 Solid & Toxic Waste Generation

Solid waste (includes domestic waste and construction waste) and toxic waste are expected to be generated by the construction activities of the Project. Improper handling, transfer, storage and disposal of solid and toxic wastes may potentially pollute the waterbodies through littering, overflow of toxic stormwater leachate collected in the uncapped waste storage containers, etc. However, the quantity of the wastes stored on-site (e.g. chemical waste, construction debris, etc.) is expected to be limited, the wastes would be periodically removed by the licensed waste management contractors, and there would be a SOP developed for safe handling, transfer, storage and disposal of solid waste, as stipulated in the minimum controls in Table 7-19. Hence, with the implementation of the abovementioned minimum control measures, it is expected that no contaminants from the construction worksite should enter the waterbodies in the Project Site and its vicinity, and there would not be an increase in turbidity, nutrients and organic contaminants in the waterbodies. Hence, the impact intensity of the solid and toxic waste generated on a change in water quality would be Medium.

In addition, another source of solid and toxic waste generation is the potential leaching of chemicals from the fill material used into the environment. The contaminated sediments sampled from Mamam Beach (N6) which exceeded the MPA guidelines would not be utilised for this Project and would be disposed of at Pulau Semakau landfill, thus minimising the potential leaching of chemicals from the fill material. As assessed in Section 7.4.3.2.2, while there were small exceedances of the As concentrations in the fill material dredged from Noordin Beach, the

concentration of As was lower than that of the existing sediments within the Sg. Durian Ponds. This implies that the potential leaching impact intensity of the contaminants in the fill material was assessed to be Negligible, compared to the existing background concentrations.

Since both human receptors such as on-site construction workers and nearby permanent off-site residents and visitors (i.e. residents at the Malay Kampung, and visitors and/or beach goers of recreational sites at Pulau Ubin) have been categorized as Priority 2 sensitive receptors, impact consequence would be Low (refer to the Table 5-8). Given that the likelihood of occurrence of spillages and leakages from the generated solid and toxic wastes is Unlikely, the impact significance on the on-site construction workers is expected to be Negligible. As the wastes will be disposed only in the designated waste disposal facilities on-site, the likelihood of this impact on nearby permanent off-site residents and visitors is considered Unlikely, and the impact significance would be Negligible (based on Impact Significance Matrix in Table 5-10).

The ecologically sensitive habitats and biocenosis in the vicinity of the Project Site may also potentially be affected by water quality contamination from solid and toxic wastes. These habitats and biocenosis are considered Priority 1 sensitive receptors, and thus the impact consequence would be Medium based on Table 5-8. Given that the likelihood of occurrence of spillages and leakages from the generated solid and toxic wastes impacting the surrounding habitats and biocenosis is Unlikely, the impact significance on the nearby habitats and biocenosis is expected to be Negligible (based on Impact Significance Matrix in Table 5-10).

The international boundary (IB) is located relatively far away from the Project Site (i.e. located closer the coastline of northern Pulau Ubin) and is considered a Priority 1 sensitive receptor. Hence, the impact consequence is expected to be Medium. Given that the IB is situated significantly far from the Project Site, the likelihood of the deterioration of water quality from solid and toxic waste generated impacting the IB is Unlikely, the impact significance on the IB would be Negligible.

7.7.1.1.1 Suspended Sediments from Construction Activities

As described in Section 3.7, the main construction activities include earth filling works at Ponds, which will cause seabed disturbance, leading to excess suspended sediment concentration (SSC) and sedimentation rates in the surrounding marine water environment if the construction works are not properly controlled. The sediment plume models have assumed the worst-case scenarios to provide a conservative assessment of environmental impacts from the sediment plume, which includes:

- The assessment was based on the peak filling rates for whole construction duration. In reality, these will only occur for a short period of time.
- The calculations of loss rates of sediment to suspension were based on conservative estimates for the types of equipment and methods of working (refer to Appendix N); and
- Assume 8 working hours/day and 7 working days/week.

Sediment plume modelling works have been carried out for the main construction activities (i.e. earth filling works) during both southwest and northeast monsoon seasons. As there will be earth filling works at Pond 2 and Pond 3 (refer to Section 3.7.2), three (3) filling scenarios, namely A-start of pond filling, B-50% of pond filling is completed, and C-end of pond filling, were set up for each pond (Figure 7-25). Hence, there are fourteen (14) simulated scenarios in total as summarised in Table 7-21.

The details of sediment plume modelling setup have been described in Appendix N.

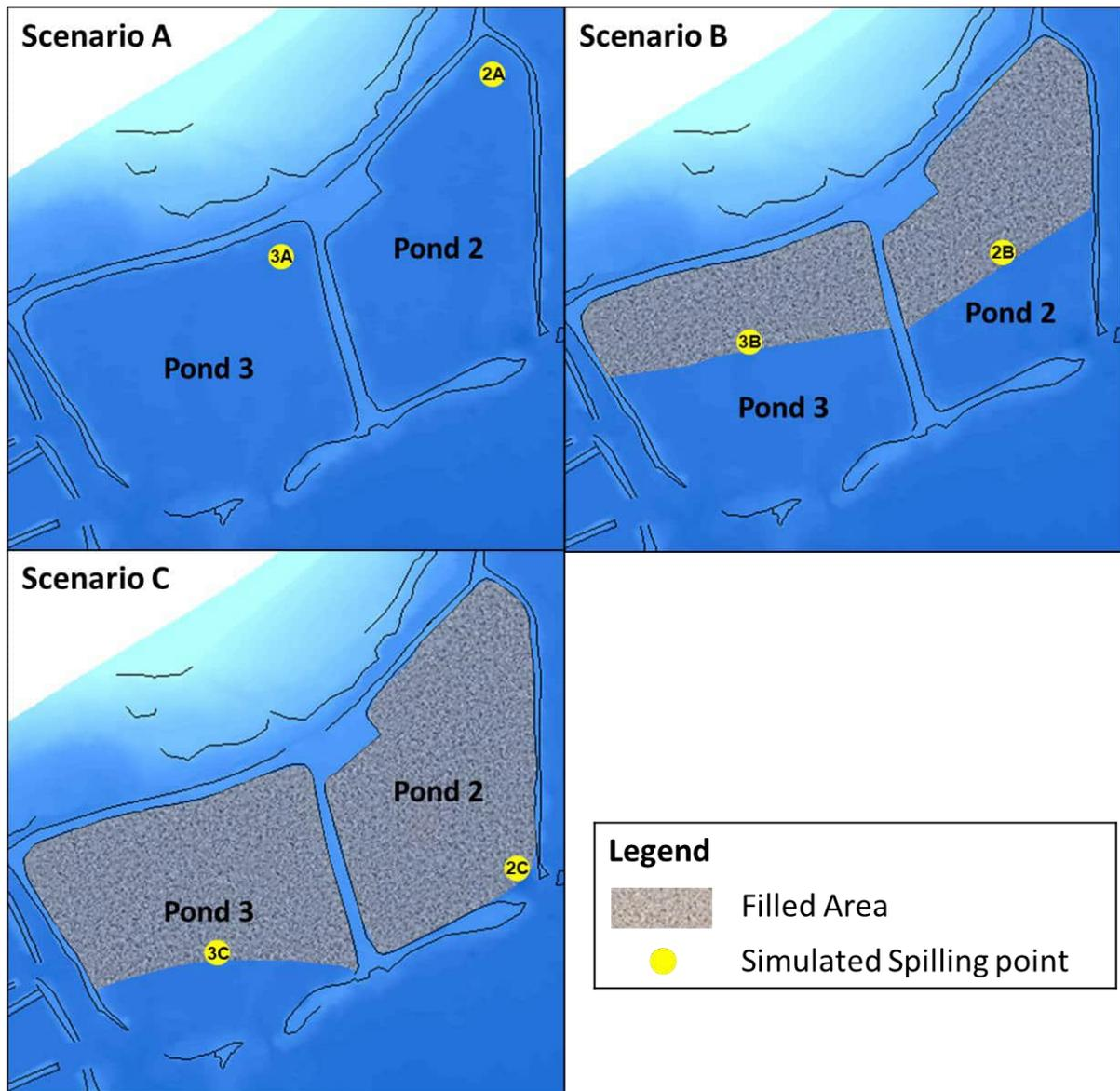

Figure 7-25 SSC spilling locations of sediment plume modelling scenarios.

Table 7-21 Sediment plume modelling scenarios.

Monsoon	No Filling Activities	With Filling Activities		
Southwest (SW)	SW-Base	A: start of pond filling	SW2A	SW3A
		B: 50% of pond filling is completed	SW2B	SW3B
		C: end of pond filling	SW2C	SW3C
Northeast (NE)	NE-Base	A: start of pond filling	NE2A	NE3A
		B: 50% of pond filling is completed	NE2B	NE3B
		C: end of pond filling	NE2C	NE3C

The assessment criteria for excess SSC and sedimentation rates are summarized in Table 7-22 and Table 7-23, with details described in the following sections. By comparing with Table 7-22 and Table 7-23, the impact significance on sensitive receptors can be predicted directly.

Table 7-22 Marine water quality impact assessment criteria on excess SSC.

Impact Significance	Seagrass	Sensitive Receptors		Visual Impact (including international boundary and recreational facilities)
		Mangrove	Aquaculture Farm	
No Negative Impact	Excess SSC > 5 mg/L for less than 20% of the time	Fully tolerant to SSC loads	Excess SSC < 5 mg/L for 95% of the time	Excess SSC < 2.6 mg/L for all the time
Slight Negative Impact	Excess SSC > 5 mg/L for more than 20% of the time, and Excess SSC > 10 mg/L for less than 20% of the time		5 mg/L < Excess SSC < 10 mg/L for 95% of the time	Excess SSC < 5 mg/L for 95% of the time
Minor Negative Impact	Excess SSC > 25 mg/L for less than 5% of the time		10 mg/L < Excess SSC < 25 mg/L for 95% of the time	Excess SSC > 5 mg/L for more than 5% of the time; and Excess SSC > 25 mg/L for less than 1% of the time
Moderate Negative Impact	Excess SSC > 25 mg/L for more than 20% of the time, and Excess SSC > 75 mg/L for more than 1% of the time		25 mg/L < Excess SSC < 200 mg/L for 95% of the time	Excess SSC > 25 mg/L for more than 1% of the time
Major Negative Impact	Excess SSC > 75 mg/L for more than 20% of the time		Excess SSC > 200 mg/L for 95% of the time	
Note:				
1. In this Study, “No” negative impacts were categorized as “Negligible” impacts, while “Slight” and “Minor” negative impacts were categorized as “Minor” impacts from SSC.				

Table 7-23 Marine water quality impact assessment criteria on mean sedimentation rate

Impact Significance	Seagrass	Sensitive Receptors	
		Mangrove	
No Negative Impact	Sedimentation < 0.1 kg/m ² /day (< 0.25 mm/day)	< 0.03 mm/day	
Slight Negative Impact	Sedimentation < 0.25 kg/m ² /day (< 0.63 mm/day)		
Minor Negative Impact	Sedimentation < 0.5 kg/m ² /day (< 1.25 mm/day)	0.03 mm/day to 1.16 mm/day	
Moderate Negative Impact	Sedimentation < 1.0 kg/m ² /day (< 2.5 mm/day)	> 1.16 mm/day	
Major Negative Impact	Sedimentation > 1.0 kg/m ² /day (> 2.5 mm/day)		
Note:			
1. In this Study, “No” negative impacts were categorized as “Negligible” impacts, while “Slight” and “Minor” negative impacts were categorized as “Minor” impacts from sedimentation rates.			

1) Suspended Sediment Concentration (SSC)

Based on the sediment plume modelling results, the predicted construction activities induced excess SSCs with minimum controls (i.e. before any mitigation measures are implemented) are summarised in Table 7-24. Typical induced suspended sediment plumes (predicted maximum at 95th percentile during a full tidal cycle) as a result of filling activities at Pond 2 and Pond 3 were shown in Figure 7-26 to Figure 7-27. The full plots of suspended sediment plumes for the simulation scenarios are presented in Appendix O.

Compared predicted excess SSC with minimum controls in Table 7-24 with assessment criteria as listed in Table 7-22. The construction activities would pose negligible negative impacts on aquaculture farms nearby, while minor negative impacts on seagrass areas (including Chek Jawa) and recreational facilities (including Serangoon Harbour, jetties, Jelutong Campsite, etc.) in the vicinity. The international boundary (IB) is to the north of Pulau Ubin, while the Project Site is in the south of Pulau Ubin, thus the chances of excess SSC expanding till northern Pulau Ubin is extremely low. Therefore, no sediment plume impact on the IB is expected.

Table 7-24 Predicted construction activities induced excess SSC with minimum control at water quality receptors during both southwest (SW) and northeast (NE) monsoon seasons.

Construction Scenarios	Predicted Excess SSC with Minimum Controls (mg/L)					
	Aquaculture (95 th percentile)		Seagrass including Chek Jawa (80 th percentile)		Recreational Facilities (i.e. Serangoon Harbour, Jetty, Jelutong Campsite, etc.)	
	SW	NE	SW	NE	SW	NE
2A	0.46	0.74	4.48	0.87	1.24	0.75
2B	1.44	0.74	5.35	1.38	3.92	0.75
2C	2.31	1.40	5.66	2.50	4.58	1.27
3A	0.58	0.74	4.86	0.88	2.86	0.92
3B	0.95	0.66	5.08	0.95	4.52	1.40
3C	1.32	0.74	5.24	1.31	5.28	1.76

Note: Any **Red values** mean the impact significance is at least moderate (refer to Table 7-22).

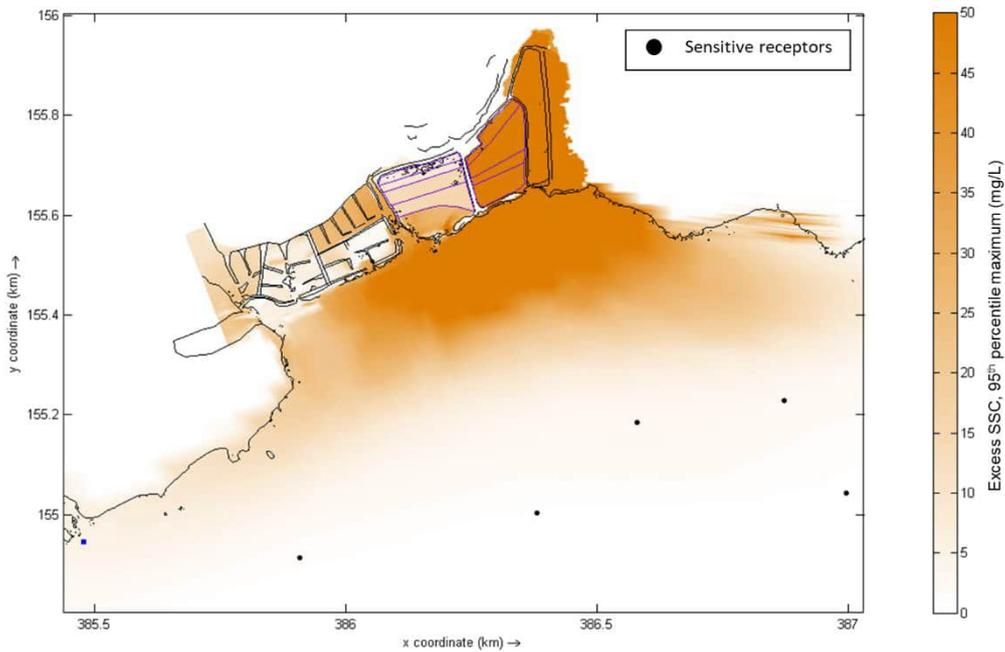

Figure 7-26 Typical maximum (95th percentile) excess SSC levels predicted from filling activities at Pond 2 with minimum controls during a full tidal cycle of southwest monsoon (SW2C).

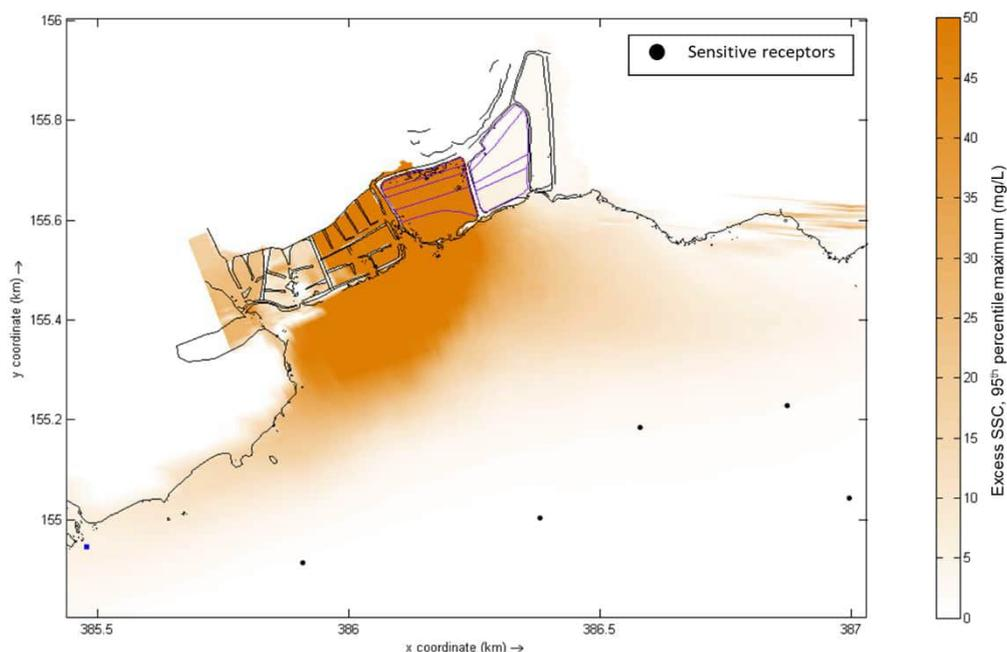

Figure 7-27 Typical maximum (95th percentile) excess SSC levels predicted from filling activities at Pond 3 with minimum controls during a full tidal cycle of southwest monsoon (SW3C).

2) Sedimentation Rate

Sediment plume models also provide the predicted construction activities induced mean sedimentation rates with minimum controls are summarized in Table 7-25.

Typical plots of mean excess sedimentation rates as a result of filling activities at Pond 2 and Pond 3 were shown in Figure 7-28 to Figure 7-29. The full plots of mean excess sedimentation rates for different simulation scenarios are presented in Appendix O.

Compared predicted mean excess sedimentation rates with minimum controls in Table 7-25 with assessment criteria as listed in Table 7-23. The construction activities would pose negligible to minor negative impacts on seagrass (including Chek Jawa). However, Minor to Major negative impacts are expected on mangroves along southern shoreline of Pulau Ubin, especially the mangrove areas just outside of the Project Site.

Table 7-25 Predicted construction activities induced mean excess sedimentation rates with minimal control at water quality receptors during both southwest (SW) and northeast (NE) monsoon seasons.

Construction Scenarios	Predicted Mean Excess Sedimentation Rates with Minimal Control (mm/day)			
	Mangrove Area (Shoreline along South Pulau Ubin)		Seagrass Area (including Chek Jawa)	
	SW	NE	SW	NE
2A	0.9	0.9	0.0	0
2B	9.3	3.2	0.2	0
2C	19.4	18.6	0.0	0
3A	0.3	0.2	0.2	0
3B	1.1	0.8	0.2	0
3C	2.0	2.9	0.3	0

Note: Red values mean the impact significance is at least moderate (refer to Table 7-23).

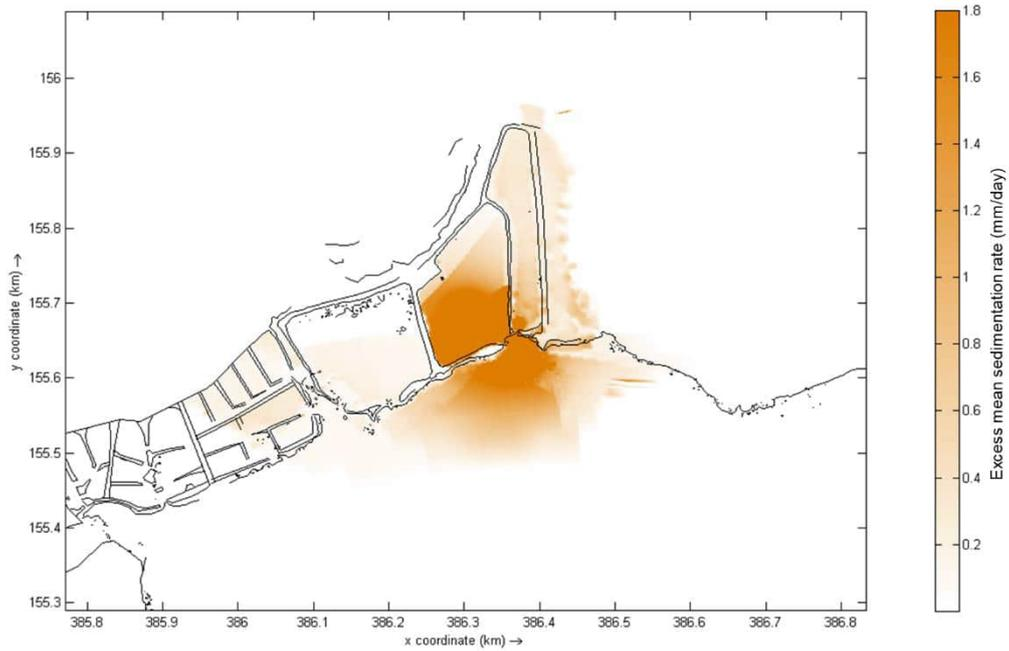

Figure 7-28 Typical mean excess sedimentation rate predicted from filling activities at Pond 2 with minimum controls during a full tidal cycle of southwest monsoon (SW2B).

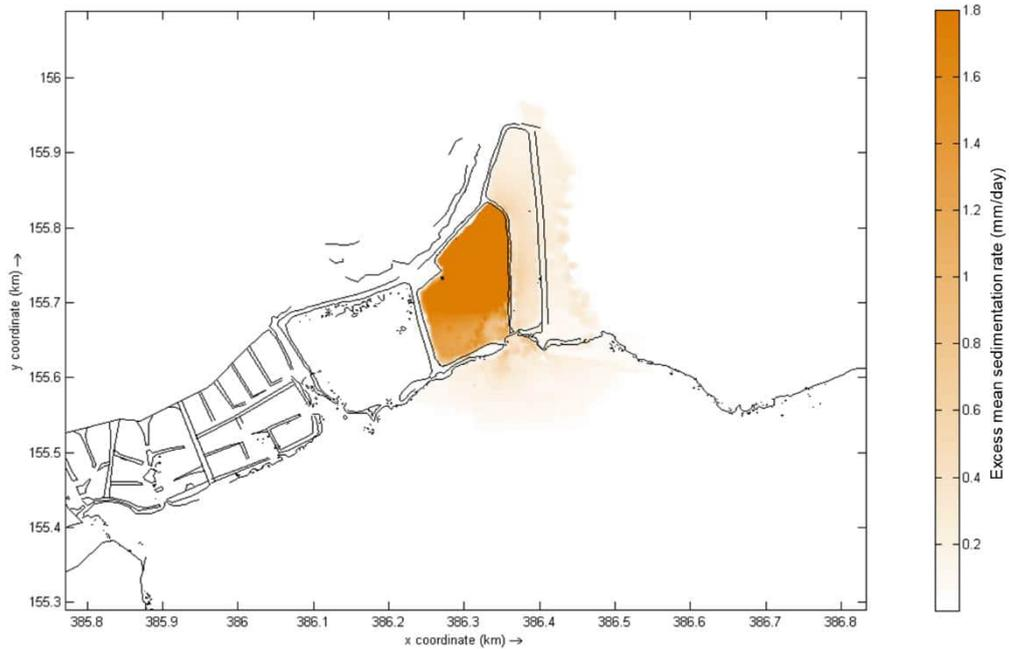

Figure 7-29 Typical mean excess sedimentation rate predicted from filling activities at Pond 3 with minimum controls during a full tidal cycle of southwest monsoon (SW3C).

7.7.1.1.2 Liquid Effluent and Stormwater Run-off Generation

Liquid effluents generated from the construction activities commonly include extracted groundwater, sanitary discharges, and stormwater runoff from exposed and unstable slopes, especially from the stockpile areas. For sanitary discharges, portable toilets will be installed as part of the minimum controls and sanitary effluents from portable toilets will be collected every week by the appointed contractor for disposal. Management controls are also expected to be implemented, such as regular inspection and housekeeping. The elevated suspended solids of liquid effluents will lead to increased turbidity and sedimentation rates within the Project Site. Given that all dredged material transported to the Project Site is expected to have met the Singapore General Guidelines on the Requirements for Application on Dredging and Dumping, the silty runoff from the stockpile area is unlikely to contain high levels of toxic heavy metals. Furthermore, since ECM will be strictly implemented within the Site and that there will not be any unmanaged discharge of wastewater streams into the waterbodies as per the minimum controls, the impact intensity of a change in water quality is expected to Medium.

Since both human receptors such as on-site construction workers and nearby permanent off-site residents and visitors have been categorized as Priority 2 sensitive receptors, the impact consequence would be Low (refer to the Table 5-8). The likelihood of occurrence of water quality contamination impacting the on-site construction worker is expected to be Unlikely. With reference to the Impact Significance Matrix in Table 5-10, the impact significance on the on-site construction workers is expected to be Negligible. On the other hand, the nearby permanent off-site residents and visitors are unlikely to be near the waterbodies during the construction phase, and thus the likelihood of occurrence of water quality contamination impacting the nearby permanent off-site residents and visitors is Unlikely, and thus the impact significance would be Negligible.

The ecologically sensitive habitats and biocenosis in the vicinity of the Project Site may also potentially be affected by water quality contamination from contaminated effluent discharge. Given that these habitats and biocenosis are considered Priority 1 sensitive receptors, and thus the impact consequence would be Medium based on Table 5-8. Given that all minimum controls from Table 7-19 are in place, and that precautionary management controls are implemented onsite (i.e. includes routine monitoring and inspections), the likelihood of occurrence of contamination of the waterbodies by liquid effluent and contaminated stormwater runoff is Unlikely, the impact significance on the nearby habitats and biocenosis is expected to be Negligible (based on Impact Significance Matrix in Table 5-10).

The international boundary (IB) is located relatively far away from the Project Site (i.e. located closer the coastline of northern Pulau Ubin) and is considered a Priority 1 sensitive receptor. Hence, the impact consequence is expected to be Medium. Given that the IB is situated significantly far from the Project Site, the likelihood of the deterioration of water quality from liquid effluent and contaminated stormwater runoff impacting the IB is Unlikely, the impact significance on the IB would be Negligible.

7.7.1.1.3 Improper Management of Chemical Substances

There are two sources of improper management of chemical substances considered for this Study, which includes the accidental mishandling of chemicals onsite and the possible subsequent oil spill that may occur due to vessel collision. Generally, the amount of chemicals utilised within the Site is expected to be in small quantities, and thus any accidental mishandling onsite may not have severe consequences. However, the potential impacts of oil spills from vessel collision would likely be more severe, and hence the worst-case scenario was assumed for this assessment. Hence, the impact intensity of a change in water quality due to accidental spillage or leakage of chemical substances would be Medium.

Since both human receptors such as on-site construction workers and nearby permanent off-site residents and visitors have been categorized as Priority 2 sensitive receptors, the impact consequence would be Low (refer to the Table 5-8). To ensure that any spillage occur onsite or within the marine waters can be contained and mitigated immediately and effectively, a detailed emergency response plan (ERP) and spill kits should prepared onsite, as well as to conducted training of an emergency response team that is competent in the response procedure. Moreover, the provision of secondary containment for all chemical waste stored in bulk, which would undergo frequent leakage detection tests, as well as the implementation of a detailed SOP to ensure the proper handling, transfer and storage of chemical substances, will also contribute to reducing the frequency and extent of impacts from chemical spillage. Additional ERP should be developed to manage a vessel collision and to establish all necessary protocols. With the implementation of these minimum controls, as well as others listed in Table 7-19, the likelihood of occurrence of such accidental chemical spills and leaks would be Unlikely. With reference to the Impact Significance Matrix in Table 5-10, the impact significance on the on-site construction workers and off-site residents and visitors caused by water quality contamination would be Negligible.

The ecologically sensitive habitats and biocenosis in the vicinity of the Project Site may also potentially be affected by water quality contamination from contaminated effluent discharge. Given that these habitats and biocenosis are considered Priority 1 sensitive receptors, and thus the impact consequence would be Medium based on Table 5-8. Given that all minimum controls from Table 7-19 are in place, the likelihood of occurrence of a deterioration in water quality by chemical spillage and leakage is Unlikely, the impact significance on the nearby habitats and biocenosis is expected to be Negligible (based on Impact Significance Matrix in Table 5-10).

The international boundary (IB) is located relatively far away from the Project Site (i.e. located closer the coastline of northern Pulau Ubin) and is considered a Priority 1 sensitive receptor. Hence, the impact consequence is expected to be Medium. Given that the IB is situated significantly far from the Project Site, the likelihood of the deterioration of water quality from spillage and leakage of chemicals impacting the IB is Unlikely, the impact significance on the IB would be Negligible.

7.7.1.1.4 Overview of Water Quality Impact

As discussed in the sections above, the evaluation of impacts on water quality and socio-economic receptors were summarized in Table 7-26.

Table 7-26 Summary of impact evaluation on water quality and socio-economic receptors.

Potential Source of Impacts	Receptor Sensitivity	Impact Intensity	Consequence	Likelihood	Impact Significance
Solid & toxic waste generation (General except SSC and sedimentation rate)	On-site construction workers (Priority 2)	Medium	Low	Unlikely	Negligible Negative
	Nearby permanent off-site residents and visitors (Priority 2)	Medium	Low	Unlikely	Negligible Negative
	Habitats and biocenosis in the vicinity of the Project Site (Priority 1)	Medium	Medium	Unlikely	Negligible Negative
	IB (Priority 1)	Medium	Medium	Unlikely	Negligible Negative
Solid & toxic waste generation (excess SSC)	Aquaculture farms (Priority 1)	N.A.	N.A.	N.A.	Negligible Negative
	Seagrass area including Chek Jawa (Priority 1)	N.A.	N.A.	N.A.	Minor Negative
	Recreational Facilities (i.e. Serangoon Harbour, Jetty, Jelutong Campsite, etc.) (Priority 3)	N.A.	N.A.	N.A.	Minor Negative
	IB (Priority 1)	N.A.	N.A.	N.A.	Negligible Negative
Solid & toxic waste generation (excess sedimentation rate)	Seagrass area including Chek Jawa (Priority 1)	N.A.	N.A.	N.A.	Negligible to Minor Negative
	Mangrove along shoreline of south Pulau Ubin (Priority 1)	N.A.	N.A.	N.A.	Minor to Major Negative
Liquid effluent and stormwater run-off generation	On-site construction workers (Priority 2)	Medium	Low	Unlikely	Negligible Negative
	Nearby permanent off-site residents and visitors (Priority 2)	Medium	Low	Unlikely	Negligible Negative
	Habitats and biocenosis in the vicinity of the Project Site (Priority 1)	Medium	Medium	Unlikely	Negligible Negative
	IB (Priority 1)	Medium	Medium	Unlikely	Negligible Negative
Improper management of chemical substances	On-site construction workers (Priority 2)	Medium	Low	Unlikely	Negligible Negative
	Nearby permanent off-site residents and visitors (Priority 2)	Medium	Low	Unlikely	Negligible Negative

Potential Source of Impacts	Receptor Sensitivity	Impact Intensity	Consequence	Likelihood	Impact Significance
	Habitats and biocenosis in the vicinity of the Project Site (Priority 1)	Medium	Medium	Unlikely	Negligible Negative
	IB (Priority 1)	Medium	Medium	Unlikely	Negligible Negative
Note:					
1. NA – “Not Applicable”. As the impact significance was assessed based on modelling results directly, the impact assessment matrix listed in Section 5.4 was not followed for assessment on excess SSC and sedimentation rates.					

7.7.1.2 Underwater Noise Impact Assessment

Noise from marine construction activities, such as general vessel traffic, is expected to be generated during construction phase, which can cause disturbance to fish, marine mammals and sea turtles, etc. Underwater noise generated during the construction phase is dependent on the type of construction works (i.e. marine piling, dredging, etc) and equipment used (e.g. size of vessel engine). Prolonged exposure to underwater noise can potentially disrupt the health and ecology of marine fauna, by causing injury (i.e. damage to body tissue), damaging the auditory system, masking of biologically important sounds (i.e. call of a mate, sound of prey/ predatory) and can also cause behaviour changes.

Based on the description of the proposed construction activities during construction phase (as listed in Section 3.7), it is confirmed that there are no planned major marine construction works (i.e. marine piling, dredging) to be conducted for this Project, which are typically known to generate high levels of underwater noise. In fact, the main underwater noise source during construction phase is the increased vessel traffic within the coastal areas of the Project Site. This increase in vessel traffic is attributed to the delivery of fill material and construction equipment from both mainland Singapore and from the north of Pulau Ubin to the Site for the construction works.

As described in Section 3.7.2.1, one (1) tugboat and its connected flattop barge will be used to transport the fill material. Typically, the larger the vessel, the lower the frequencies produced which therefore results in the emitted noise travelling greater distances. However, the tugboat proposed for this Project is considered a small vessel (i.e. defined as less than 50 m in length) [R-26], which is known to generate smaller underwater noise impacts due to its smaller engine. The vessel engine is characterised as a single short-term intermittent noise source, as it is assumed that there will be limited trips to the Project Site per day.

As shown in Section 7.4.5, the noise from shipping activities is a significant contributor to the underwater noise ambient environment along Serangoon Harbour, especially since Serangoon Harbour is a heavily utilised navigation channel, by both large and small cargo vessels. Hence, the marine fauna in the vicinity of the Project Site, especially those that are non-mobile – such as fish from aquaculture farms – are likely already frequently exposed to the noise generated by boat traffic.

Since the habitats and biocenosis in the vicinity of the Project Site are exposed to elevated ambient underwater noise levels, they might have adapted to such ambient conditions. Furthermore, given that the size of the tugboat (i.e. 8.5 m in length, capacity of 12.7 tonnes) is significantly smaller than other large container ships (i.e. up to 400m in length, with average capacity of 220,000 tonnes) that utilise the navigation channel, the impact intensity of underwater noise due to increased vessel traffic would be Very Low. Since the habitats and biocenosis in the vicinity of the Project Site are considered Priority 1 receptors, the impact consequence would be Very Low. Although there will be minimum controls implemented, such as turning off the engine when the boat is idle and/or during off-loading the fill material into the pontoon barge, the transportation of materials to the Site will likely be frequent throughout the construction period. Hence, the likelihood of occurrence of impacts to the habitats and biocenosis in the vicinity of the Project Site would be Regular, and hence the impact significance is Minor.

With respect to the fish farm, the estimated off-loading point of the flattop barge is nearly equidistant from the busy navigation channel. This indicates that the fish in the aquaculture farms are currently exposed to a higher ambient noise environment. Furthermore, given that the size of the tugboat is significantly smaller than other large container ships that utilise the navigation channel, the impact intensity of underwater noise due to increased vessel traffic would be Very Low. Since aquaculture farms are considered Priority 1 receptors, the impact consequence would be Very Low. Although there will be minimum controls implemented, the transportation of materials to the Site will

likely be on a regular basis throughout the construction period. Hence, the likelihood of occurrence of impacts to the fish in the fish farms would be Regular, and hence the impact significance to the fish farms is Minor.

7.7.2 Operational Phase

7.7.2.1 Hydrodynamics Impact Assessment

The hydrodynamic model applied to the Project Site and its vicinity describes the effect of the mangrove restoration works within Pulau Ubin on the marine current regime. Model simulations were performed using a full 14-day spring-neap tidal cycle. Model scenarios includes both without development (baseline) and with development phases of the proposed mangrove restoration works (after the pond filling is completed). Detailed description of the model set-up is presented in Appendix N. Changes to currents were analysed based on maximum (i.e. 95th percentile) current speed.

7.7.2.1.1 Changes to 95th Percentile Current Speed in the Vicinity of Project Site

The maximum (95th percentile) current speeds without and with development in the vicinity of Project over one tidal cycle are presented in Figure 7-30. Differences in the maximum (95th percentile) current speeds between the respective without and with development phases are presented in Figure 7-31. In Pond 2, the maximum current speed could be reduced slightly by less than 0.17 m/s within the pond due to the reduction of flow capacity of ponds after the filling activities, while increased slightly by less than 0.15 m/s at the pond opening area due to the proposed gabion block structure. In Pond 3, the maximum current speed could be reduced slightly by less than 0.1 m/s all over the pond due to the reduction of flow capacity of ponds after the filling activities. Generally, the changes in current speed are mainly localised within the ponds or at the opening of the pond areas, while there are almost no changes (around 0 m/s) in the southeast coast of Pulau Ubin (i.e. Serangoon Harbour) (Figure 7-31). Hence, the proposed mangrove restoration works will have negligible impact on the vessel navigation nearby.

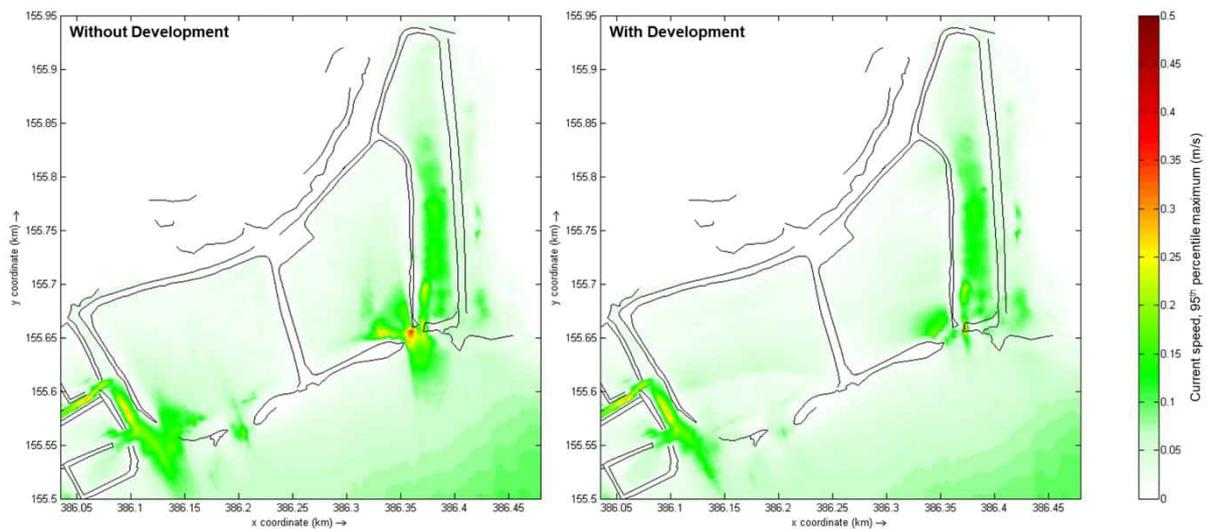

Figure 7-30 Maximum (95th percentile) current speed in the vicinity of Project Site during one tidal cycle of without and with development phases.

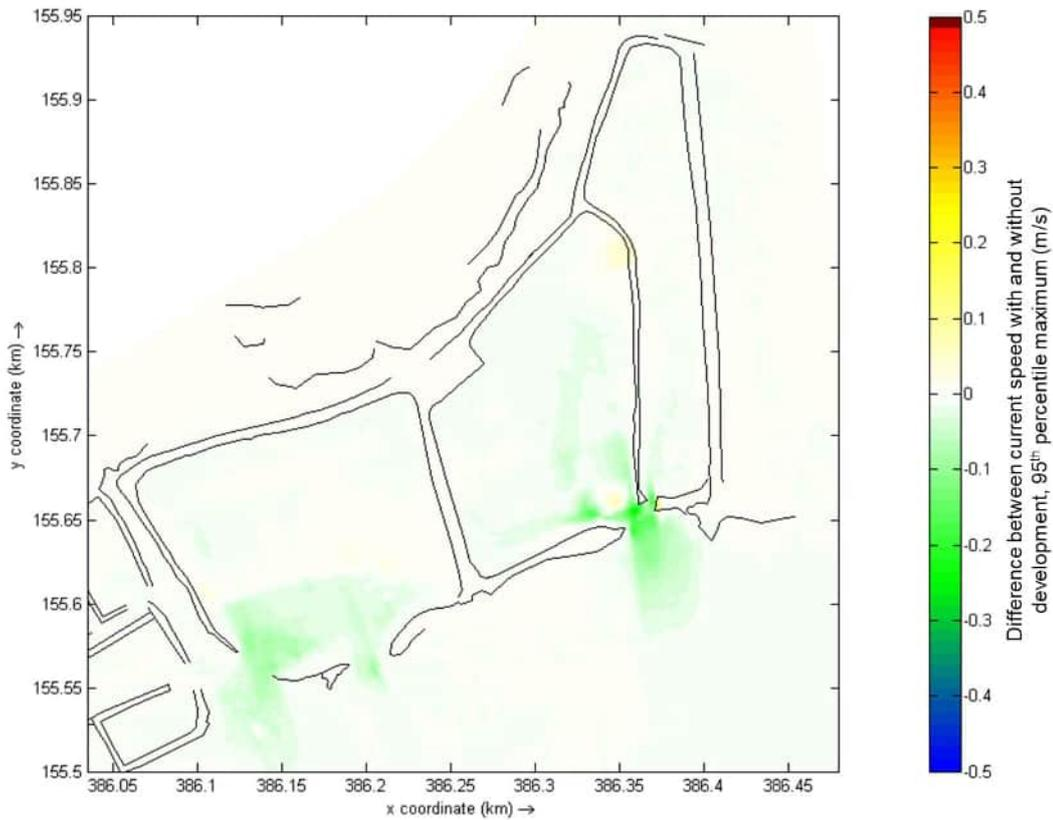

Figure 7-31 Difference in maximum (95th percentile) current speed in the vicinity of Project Site during one tidal cycle between without and with development phases.

7.7.2.1.2 Hydrodynamic Impacts to International Boundary (IB)

Based on model results already presented in Figure 7-31, the intensity of change in offshore maximum current speed (almost 0 m/s) to the south of Pulau Ubin as a result of the mangrove restoration works will have no/negligible impact to the international boundary to the north of Pulau Ubin.

7.7.2.1.3 Overview of Hydrodynamic Impact

As described in section above, the proposed mangrove restoration works will not result in any impact on the navigation channel to the south of Pulau Ubin (i.e. Serangoon Harbour), as the changes in current speed are mainly localised within the ponds or at the opening of the pond areas.

Table 7-27 Summary of impact evaluation on hydrodynamics.

Potential Source of Impacts	Receptor Sensitivity	Impact Intensity	Consequence	Likelihood	Impact Significance
Changes in Current Regime	Navigation Channel to the south Pulau Ubin (i.e. Serangoon Harbour) (Priority 3)	Negligible	Imperceptible	Unlikely	Negligible Impact
Note: 'Negligible' is equivalent to 'No Negative Impact'.					

7.7.2.2 Marine Water Quality Impact Assessment

As described in Table 7-10, the major sources of impacts on marine water quality during operational phase are improper management of liquid and solid wastes. The contamination of marine water quality may lead to potential socio-economic impacts (i.e. impacts to IB) and possible human health risks to visitors and permanent residents in the vicinity of the proposed development, as per the sensitive receptors identified in Table 7-18. The sources of impacts will be assessed qualitatively using the risk matrix method as presented in Section 5.4.

7.7.2.2.1 Improper Management of Liquid and Solid Wastes

During operational phase, with the successful reestablishment of mangrove in the long-term, the mangrove roots could help to trap sediments and prevent sediment erosion within the Ponds. This will lead to positive impacts on both human and ecological sensitive receptors from the proposed development.

However, the Project Site will be also opened for visitors to observe the mangrove restoration progress, and thus it is expected that there would be an increase in human traffic within the Site. This may lead to an associated increase in solid and liquid waste generated at the Site, which may imply that the surrounding waterbodies may become contaminated due to inappropriate disposal and discharge of such wastes onsite. The impact intensity of the deterioration of water quality from such solid and liquid wastes would be Low.

Since the visitors and permanent residents in the vicinity of the proposed have been categorized as Priority 2 sensitive receptors, the impact consequence would be Very Low (refer to the Table 5-8). Given that there will be provision of sufficient monkey-proof waste disposal bins, there will also be sufficient training provided for maintenance workers to immediately and effectively contain and mitigate any accidental water contamination, and that the public will have limited access into the Ponds, the likelihood of occurrence of being in contact with the contaminated waters (if any) would be Unlikely. With reference to the Impact Significance Matrix in Table 5-10, the impact significance on the on-site construction workers is expected to be Negligible.

The ecologically sensitive habitats and biocenosis in the vicinity of the Project Site may also potentially be affected by water quality contamination from the improper storage and disposal of solid and liquid wastes onsite. Given that these habitats and biocenosis are considered Priority 1 sensitive receptors, and thus the impact consequence would be Low based on Table 5-8. Given that there would be warning signages installed within the Project Site and its vicinity and that the waterbodies would be monitored via CCTV surveillance regularly to ensure no contamination as well as the implementation of other minimum controls from Table 7-20, the likelihood of occurrence of an impact on the surrounding habitats and biocenosis due to a deterioration in water quality by improper solid and liquid waste management is Unlikely, the impact significance on the nearby habitats and biocenosis is expected to be Negligible (based on Impact Significance Matrix in Table 5-10).

The international boundary (IB) is located relatively far away from the Project Site (i.e. located closer the coastline of northern Pulau Ubin) and is considered a Priority 1 sensitive receptor. Hence, the impact consequence is expected to be Low. Given that the IB is situated significantly far from the Project Site, the likelihood of the deterioration of water quality from the improper management of solid and waste impacting the IB is Unlikely, the impact significance on the IB would be Negligible.

7.7.2.2.2 Overview of Water Quality Impact

As discussed in the sections above, the evaluation of impacts on water quality and socio-economic receptors were summarized in Table 7-26.

Table 7-28 Summary of impact evaluation on water quality and socio-economic receptors.

Potential Source of Impacts	Receptor Sensitivity	Impact Intensity	Consequence	Likelihood	Impact Significance
Improper Management of Liquid and Solid Wastes	Visitors and permanent residents in the vicinity of the proposed development (Priority 2)	Low	Very Low	Unlikely	Negligible Negative to Positive
	Habitats and biocenosis in the vicinity of the Project Site (Priority 1)	Low	Low	Unlikely	Negligible Negative to Positive

Potential Source of Impacts	Receptor Sensitivity	Impact Intensity	Consequence	Likelihood	Impact Significance
	International Boundary (IB) (Priority 1)	Low	Low	Unlikely	Negligible Negative to Positive

7.7.2.3 Coastal Morphological Impact Assessment

Morphology involves the study of the seabed condition as a result of induced hydrodynamic changes and sediment transportation. In this study, 5-year changes in bathymetry level (erosion and sedimentation profiles) in the vicinity of Project Site were simulated with morphology modelling.

7.7.2.3.1 Morphological Impact to Project Site

Figure 7-32 presents the difference in predicted 5-year changes in the bathymetry levels between with and without mangrove restoration works. Within the ponds, the increased bed level in both Ponds 2 and 3 is due to pond filling works. At the opening of Pond 3, the erosion becomes less with proposed development compared with the condition without proposed development due to its reduced flow capacity and current speed in the Pond 3, which is deemed a positive impact there. In addition, if the future mangrove propagation progresses well as planned, mangroves will help to trap the sediments and prevent erosion within the pond, which again suggests the overall mangrove restoration works will have positive impact in the surrounding marine morphology. Outside of the pond areas, the proposed mangrove restoration works will not have any impact on the southern shoreline of Pulau Ubin as shown in Figure 7-32.

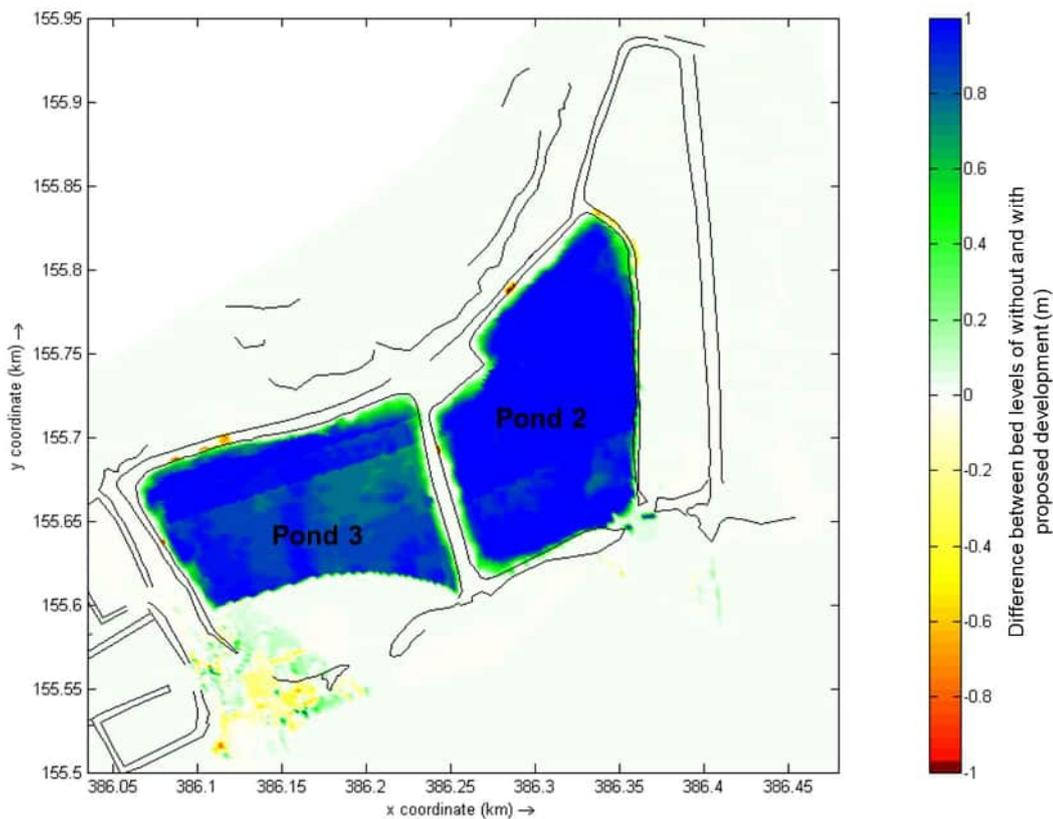

Figure 7-32 Difference in predicted bed levels after five (5) years at Sg Jelutong area between without and with development scenarios (note: positive values – increase in bed level compared to baseline condition; negative values – reduce in bed level compared to baseline condition).

7.7.2.3.2 Morphological Impact to International Boundary (IB)

As discussed in section above, morphological changes were more likely to be localised at the proposed development area. Hence, its impact intensity on IB was also expected to be negligible.

7.7.2.3.3 Overview of Morphological Impact

As described in section above, morphological changes will be more likely to be localised at the proposed development area. The proposed development will result in slight positive impact at the opening of Pond 3, while negligible negative impact in the vicinity of Project Site and IB.

Table 7-29 Summary of impact evaluation on morphology.

Potential Source of Impacts	Receptor Sensitivity	Impact Intensity	Consequence	Likelihood	Impact Significance
Erosion or sedimentation due to changed current	Pond Areas (Priority 1)	Negligible Negative	Very Low Negative	Unlikely	Negligible Negative to Positive
	Southern Shoreline of Pulau Ubin (Priority 1)	Negligible Negative	Very Low Negative	Unlikely	Negligible Negative
	IB (Priority 1)	Negligible Negative	Very Low Negative	Unlikely	Negligible Negative
Note: For positive impact, no impact assessment matrix was applied.					

7.8 Recommended Mitigation Measures

In this section, mitigation measures were proposed to further minimise the adverse impacts on the environment where impact significance were assessed to be Moderate or Major during both construction and operational phases.

7.8.1 Construction Phase

During construction phase, the construction activities were expected to have mainly negligible to minor negative impacts on underwater noise, marine water quality in terms of solid and toxic waste generation (including SSC), liquid effluent and stormwater run-off generation, as well as management of chemical substances. Hence, no additional mitigation measures other than the minimum controls identified and incorporated in the construction plans are required. However, the predicted induced sedimentation rates from sediment plume would have minor to major negative impacts on the surrounding sensitive receptors, especially the mangrove area immediately outside of the pond areas.

7.8.1.1 Minimise

To minimize the transportation of induced suspended sediments during construction period, Cage Type Grab Dredger, which can reduce sediment spill, should be used. During the filling activities, double layers of silt curtains should be added surrounding the working areas to prevent sediment plume impact, especially to reduce the sedimentation rates of SSC. In addition, water quality monitoring plan should be set up during construction period.

While underwater noise impacts were expected to be minor negative, to further reduce the underwater noise generated by the boat engine, it is recommended that the boat engine is switched off when transferring the fill material from the flattop barge to the modular barge.

7.8.2 Operational Phase

During operational phase, the operational activities will have only negligible negative to even some positive impacts on marine water as assessed in previous section. Hence, no additional mitigation measures other than the minimum controls identified and incorporated in the construction plans are required.

7.9 Residual Impacts

A residual impact assessment has been undertaken assuming the mitigation measures recommended for construction phase in the previous section have been implemented. No residual impacts were assessed for operational phase as no mitigation measures are required.

As shown in Table 7-30, with the implementation of the recommended mitigation measures in conjunction with the identified minimum controls, the mean excess sedimentation rates will be reduced to below 0.4 mm/day at the mangrove areas during both SW and NE Monsoons. Typical plots of mean excess sedimentation rates as a result of filling activities at Pond 2 and Pond 3 after implementation of mitigation measures as mentioned above were shown in Figure 7-28 to Figure 7-29. Hence, the residual impact on marine water can be reduced to Negligible to Minor negative impact during construction phase as summarised in Table 7-31.

Furthermore, by ensuring that the engine is switched off when onloading and offloading of the fill material, the underwater noise impact significance to both habitat and biocenosis and aquaculture farms can be reduced from minor to negligible negative.

Table 7-30 Predicted construction activities induced mean excess sedimentation rates with mitigation measures (double layers of silt curtains) at water quality receptors during both southwest (SW) and northeast (NE) monsoon seasons.

Construction Scenarios	Predicted Mean Excess Sedimentation Rates with Mitigation Measures – double layers of silt curtains (mm/day)			
	Mangrove Area (Shoreline along South Pulau Ubin)		Seagrass Area (including Chek Jawa)	
	SW	NE	SW	NE
2A	0.0	0.0	0	0
2B	0.1	0.1	0	0
2C	0.4	0.4	0	0
3A	0.0	0.0	0	0
3B	0.0	0.0	0	0
3C	0.0	0.1	0	0

Note: Red values mean the impact significance is at least moderate (refer to Table 7-23).

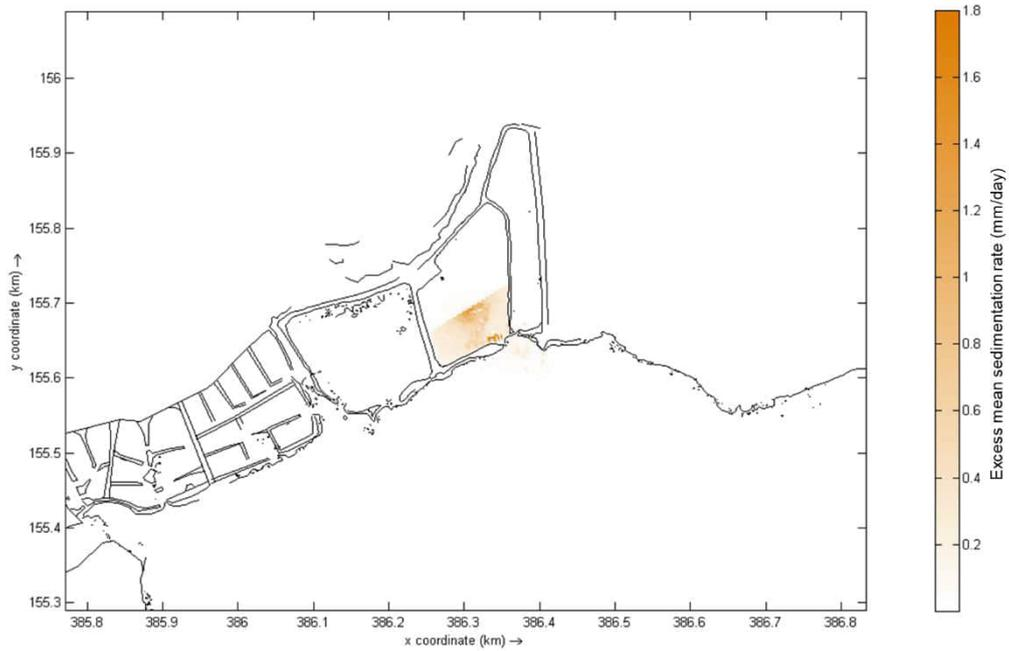

Figure 7-33 Typical mean excess sedimentation rate predicted from filling activities at Pond 2 with mitigated measures during a full tidal cycle of southwest monsoon (SW2B).

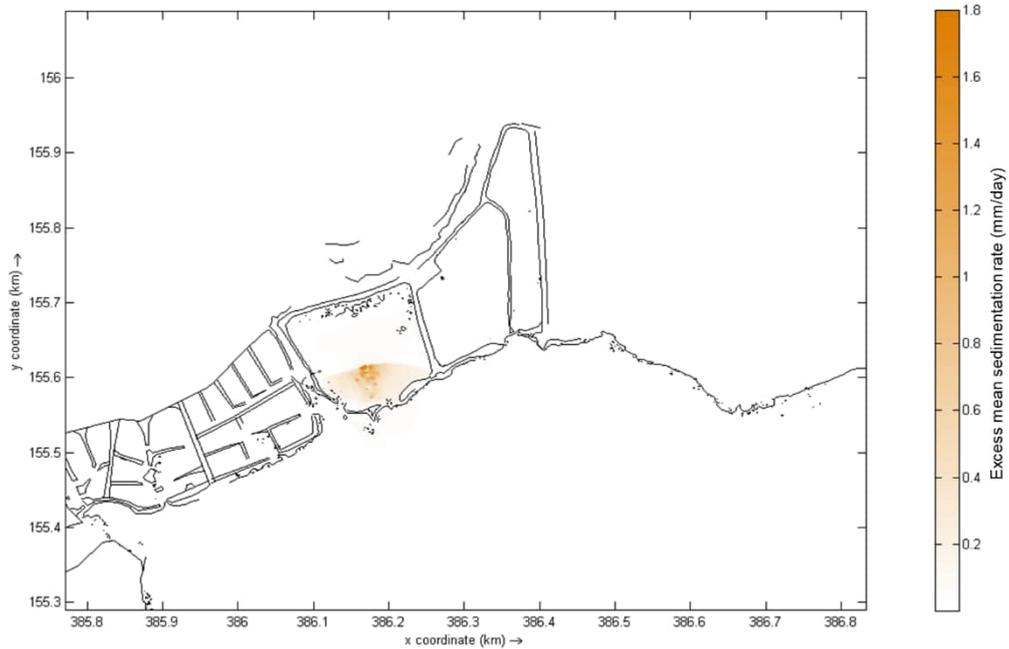

Figure 7-34 Typical mean excess sedimentation rate predicted from filling activities at Pond 3 with mitigated measures during a full tidal cycle of southwest monsoon (SW3C).

Table 7-31 Summary of residual impacts and its mitigation measures.

Activity	Receptor Sensitivity	Impacts	Impact Significance (with minimum controls)	Mitigation Measures	Significance of Residual Impact (with mitigation measures)
During construction phase: • Earthworks, pond filling, storage and transportation of filling material transportation	Mangrove Area (Priority 1)	Increased sedimentation rates due to induced SSC	Minor to Major	<ul style="list-style-type: none"> To use Cage Type Grab Dredger To install double layers of silt curtains surrounding the working areas when pond filling activities are carried out 	Negligible to Minor
	Habitats and biocenosis in the vicinity of Project Site (Priority 1)	Increased underwater noise levels	Minor	<ul style="list-style-type: none"> Switch off boat engine during onloading/offloading of fill material. 	Negligible
	Aquaculture farms (Priority 1)				

7.10 Cumulative Impacts from Other Major Concurrent Projects

During construction phase, there are two (2) main projects whose construction phase is taking place concurrently within 2-km radius of this Project (refer to Section 3.10).

The enhancement of fire safety infrastructure for Pulau Ubin at the Malay Kampung and Main Village is a land-based project, with no construction works to be carried out in the marine environment. As such, the abovementioned concurrent project will not contribute to cumulative impacts on this Project. The other concurrent project includes the shoreline restoration works at Pulau Ubin. While major construction works will be carried out in the marine waters at Noordin Beach and Mamam Beach, these works are located at a significant distance away from this Project Site. Generally, this Project only involves minor construction works within marine waters (i.e. pond filling only), and thus the impacts to marine water quality and ecology are largely localised. Hence, other water-based construction projects such as shoreline restoration works will have negligible to minor negative cumulative impacts on this mangrove restoration Project Site.

7.11 Summary of Key Findings

The marine water baseline surveys determined the marine hydrodynamics, water quality, and sediment quality and size distribution in the vicinity of Project Site.

The annual hydrodynamic conditions in the vicinity of Project Site are characterised by the two monsoon seasons, namely, the Southwest (SW) Monsoon occurring from June to September while the Northeast (NE) Monsoon occurring from December to early March. The hydrodynamic currents of Singapore are dominated by semi-diurnal pattern. In the vicinity of Project Site, currents flow in and out of the pond areas along with the tide cycles with a tidal range of around 3.4m in the offshore area. During both NE and SW Monsoon seasons, especially at the pond opening areas, the current could reach up to 0.79 m/s during spring tide, while up to 0.56 m/s during neap tide.

The waterbodies in the Project Site and its vicinity were surveyed during four tidal conditions – Spring-Flood, Spring-Ebb, Neap-Flood, Neap-Ebb, to capture the possible changes in the physicochemical composition of marine water during different tidal conditions. The six (6) water quality sampling stations are located at the back mangrove area at the east of Project Site, Pond 1, Pond 2, Pond 3, coastal area just south of the Project Site and an offshore area near the aquaculture farms. Generally, the baseline water quality across all sampling stations were relatively suitable for aquatic life, with minimal variation across the stations. DO was found to be below the ASEAN marine water quality guidelines for aquatic life at the back mangrove area, due to its relatively stagnant flow conditions and

aquatic fauna was not observed onsite. Its upstream was found to have brackish waters, while its downstream was seawater. It was found that there was generally high nutrients concentration for all water quality sampling stations, which was consistent with previous studies within the Serangoon Harbour. The presence of other chemical compounds was relatively low across all sampling locations and were well within their respective criteria limits. However, tributyltin was found to exceed the AMWQC limits at all stations, and the source was likely from the marine environment. Biological pollutants (i.e. *enterococcus* and faecal coliform) was found to exceed the AMWQC for human health protection at sampling stations near the Project Site, which implies that it was likely contributed from animal faecal matter in the terrestrial environment. This may imply that the baseline water quality may pose human health risks if primary contact activities be conducted within the waters.

Sediment samples were collected at eight (8) sampling locations, from the back mangrove area, near the bunds and middle of each Pond and the coastal area just south of the Project Site. Generally, the sediments from the middle of each Pond had a higher composition of fine sediments. The sediments collected near the bunds generally had relatively equal sand and silt composition, while the coastal area had a high proportion of sand. The sediment quality mostly met MPA General Guidelines on the Requirements for Application on Dredging and Dumping Works, with only a slight exceedance in arsenic concentrations at the back mangrove area. This was attributed to the characteristics of mangrove soils to uptake and accumulate arsenic. The baseline sediment quality established that any future contamination identified within the Project Site is unlikely to originate from the existing sediments.

Underwater noise monitoring was conducted at one (1) offshore location along Serangoon Harbour in the vicinity of the Project Site. The ambient background noise levels at Serangoon Harbour which are within the hearing sensitivities of fishes (i.e. 30 Hz to 5 kHz [P-80]) range between 70 – 110 dB (5th to 95th percentiles). Generally, the baseline ambient underwater noise environment is well below the threshold value of 158 dB re 1 µPa of impairment to fishes (refer to Table 7-8). Background levels within the hearing sensitivities of dugongs (i.e. 1 kHz to 18 kHz [P-81]) – known to be found along the East Johor Strait (refer to Appendix E) – ranges between 90 to 110 dB (5th to 95th percentiles). Currently, little is known about the threshold for detectable auditory responses by dugongs. For cetaceans like Irrawaddy dolphin (*Orcaella brevirostris*), Indo-pacific humpbacked dolphin (*Sousa chinensis*), Indo-pacific bottlenose dolphin (*Tursiops aduncus*) – refer to Appendix E for expected species list near the site – the baseline sound pressure level is within 90 – 105 dB (5th to 95th percentiles) of their hearing range of 150 Hz to 160 kHz [P-82], which is well below the onset threshold of 120 dB RMS for continuous noises (refer to Table 7-6).

Based on the assessment of marine water-related impacts on the various sensitive receptors, the findings have been summarised in Table 7-32 below.

In the long-term, once the mangroves are successfully regenerated throughout the Project Site as planned, the mangroves will help to trap the sediments and prevent soil erosion within the Ponds. This suggests that the overall mangrove restoration works will have a positive impact on the morphology of the Project Site and the surrounding coastal areas.

The activities of construction and operational phases were predicted to impact water quality (excluding impacts from sediments) in the marine environment. However, upon impact evaluation, these impacts were assessed to cause **Negligible Negative – Positive** impacts on human receptors and the habitat and biocenosis near the Project Site during construction and operational phases, with implemented minimum controls.

However, for the water quality impacts related to the suspended solids generated in this Project, the impacts to the mangroves along the southern shoreline of Pulau Ubin during construction phase was predicted to be **Minor – Major Negative**, especially for the mangrove areas just outside the Project Site. As such, mitigation measures such as the use of Cage Type Grab Dredger should be used to minimise sediment spills and two layers of silt curtains should be installed around the working areas to mitigate the impacts of sediment plumes and to reduce the sedimentation impact of the SSC on the surrounding receptors. An effective water quality monitoring plan should also be implemented during the construction phase. With these measures in place, the residual impacts are expected to be reduced to **Negligible – Minor Negative**.

Furthermore, the impact significance of the increased underwater noise levels generated during the construction phase in this Project was assessed to be **Minor Negative**, but after mitigation measures such as switching off the boat engine when offloading the fill material, the impact significance on the habitats and biocenosis in the vicinity of Project Site and aquaculture farms is expected to be reduced to **Negligible Negative**.

There are two (2) concurrent construction projects with overlapping construction periods with this Project, but were not found to contribute to cumulative impacts on this Project. This is because the project on the enhancement of

fire safety infrastructure in the Malay Kampung and Main Village are in-land projects, therefore does not contribute to marine impacts on this Project. Furthermore, the shoreline restoration project at Noordin Beach and Mamam Beach are located far away from the Project Site, and therefore the construction impacts on the water quality will have **Negligible – Minor Negative** cumulative impacts to this Project.

Table 7-32 Summary of marine water impact assessment.

Environmental Parameter	Sensitive Receptor	Impact Significance with Minimum Control	Key Mitigation Measures (if any)	Residual Impact Significance with Mitigation Measures (if required)
Construction phase				
Marine Water Quality (excluding sediment plume)	On-site construction workers	Negligible Negative	N.A.	N.A.
	Off-site residents and visitors (recreational facilities including Serangoon Harbour, jetties, Jelutong Campsite, etc.)	Negligible Negative	N.A.	N.A.
	Habitats and biocenosis in the vicinity of Project Site	Negligible Negative	N.A.	N.A.
	International Boundary (IB)	Negligible Negative	N.A.	N.A.
Sediment Plume	Off-site residents and visitors (recreational facilities including Serangoon Harbour, jetties, Jelutong Campsite, etc.)	Minor Negative	N.A.	N.A.
	Seagrass (including Chek Jawa)	Minor Negative	N.A.	N.A.
	Mangrove along the southern shoreline of Pulau Ubin	Minor to Major Negative	<ul style="list-style-type: none"> To use Cage Type Grab Dredger To install double layers of silt curtains surrounding the working areas when pond filling activities are carried out 	Negligible to Minor Negative
	Aquaculture farms	Negligible Negative	N.A.	N.A.
	International Boundary (IB)	Negligible Negative	N.A.	N.A.
Underwater Noise	Habitats and biocenosis in the vicinity of Project Site	Minor Negative	<ul style="list-style-type: none"> Switch off boat engine when onloading/ 	Negligible Negative

Environmental Parameter	Sensitive Receptor		Impact Significance with Minimum Control	Key Mitigation Measures (if any)	Residual Impact Significance with Mitigation Measures (if required)
	Aquaculture farms		Minor Negative	offloading fill material.	Negligible Negative
Operational Phase					
Marine Quality	Water	Off-site residents and visitors	Negligible Negative to Positive	N.A.	N.A.
		Habitats and biocenosis in the vicinity of Project Site	Negligible Negative to Positive	N.A.	N.A.
		International Boundary (IB)	Negligible Negative to Positive	N.A.	N.A.
Hydrodynamic	Navigation channel near the southern coast of Pulau Ubin (i.e. Serangoon Harbour)		Negligible Negative	N.A.	N.A.
	International Boundary (IB)		Negligible Negative	N.A.	N.A.
Morphology	Habitats and biocenosis in the vicinity of Project Site		Negligible Negative to Positive	N.A.	N.A.
	International Boundary (IB)		Negligible Negative	N.A.	N.A.
Note:					
1. N.A. – as the negative impact significance is below moderate, no mitigation measures are required and no residual impact was assessed.					

8 Environmental Monitoring and Management Plan

The proposed Environmental Monitoring and Management Plan (EMMP) is prepared for environmental impacts of the construction and operational phases associated with the Project, and that were assessed in this EIA study, namely biodiversity, marine water quality, underwater noise, hydrodynamics and morphology. The EMMP details how the recommended mitigation measures prepared for the impact assessment are to be implemented and specifies recommended monitoring measures to assess the effectiveness of the mitigation measures. This document is also intended to provide a broad framework for the Environmental Control Officer (ECO) to develop a contract-specific EMMP, as per their responsibilities in Section 8.4.5. Since the Project will evolve over time, the EMMP is an adaptive document meant to be amended where necessary. Copies of the EMMP must be kept on-site for reference at all times.

This section outlines the objectives of the EMMP, the Project organisation, describes the roles and responsibilities relevant to implementation of the EMMP, and summarises the EMMP requirements for each discipline.

8.1 EMMP Objectives

The EMMP details the implementation and deliverables of the key mitigation measures recommended from the impact assessment for each technical discipline. The EMMP progressively scrutinises construction and operational activities as they ensue and applies flexible monitoring and management procedures to protect the Project's environmental values throughout the Project period. The objective of the EMMP is twofold:

- a) Environmental monitoring focuses on overseeing those impacts to the Project's environmental values from construction and operational phases are within the anticipated level and tackle unforeseen impacts that may arise; and
- b) It also tracks the effectiveness of the recommended mitigation measures to allow amendment or review of the mitigation measures to better address any issues faced during construction and operational phases of the Project.

Environmental management employs a more active approach to ensure those impacts on flora and fauna, and human beings are directly avoided through documentation, auditing and enforcement.

8.2 Project Organisation during the Construction Phase

The roles and responsibilities of the various parties responsible for implementing the EMMP during the construction phase are outlined below. The proposed Project organization and lines of communication with respect to environmental protection works are presented in Figure 8-1.

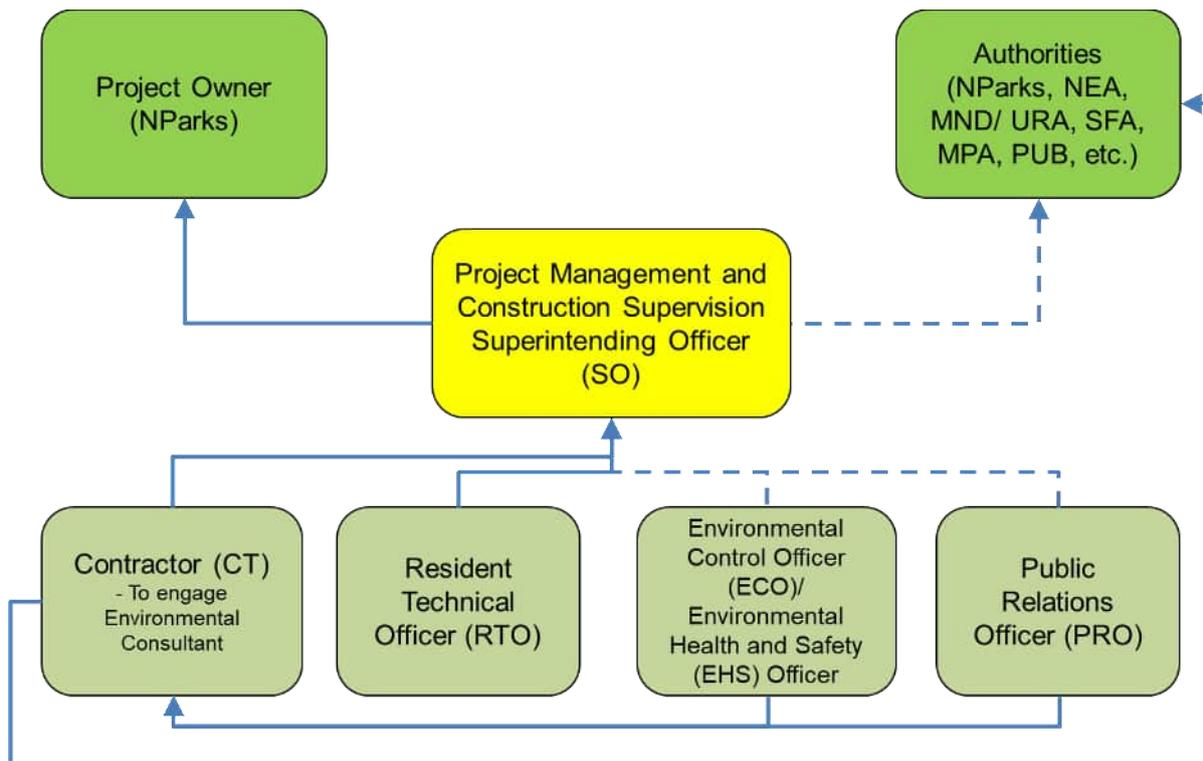

Figure 8-1 Project organization and lines of communication during the construction phase.

8.3 Project Organisation during the Operational Phase

The roles and responsibilities of the various parties responsible for implementing the EMMP during the operational phase are outlined below. The proposed Project organization and lines of communication with respect to environmental protection works are presented in Figure 8-2.

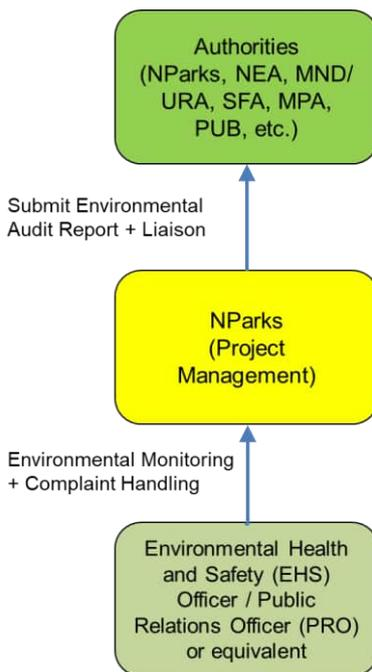

Figure 8-2 Project organization and lines of communication during the operational phase.

8.4 Roles and Responsibilities of the EMMP for the Construction Phase

8.4.1 Technical Agencies

Technical agencies constitute but are not limited to NParks, PUB, NEA, MPA and URA. These agencies shall assess and approve the detailed EMMP for the construction phase prior to commencement of works and where required during the course of the Project.

8.4.2 Project Owner (NParks) and Resident Technical Officer

NParks, being the Project owner oversees the construction phase of the Project in accordance with the design. NParks, in conjunction with the Resident Technical Officer (RTO) (Contractor), are required to:

- Ensure resources are available to achieve the requirements of the EMMP;
- Provide leadership in the development and implementation of the EMMP;
- Ensure all environmental incidents and near misses are promptly investigated and reported;
- Resolve any non-compliance issues;
- Record, respond to, and action any complaints from members of the public, if any, with inputs from the Technical Agencies, if required; and
- Reporting to the Technical Agencies regarding implementation of the EMMP.

8.4.3 The Superintending Officer (SO)

The Superintending Officer is responsible for overseeing the construction works undertaken by various staff, Contractors and sub-contractors. The SO should ensure that the construction works are performed by the Contractors and personnel in accordance with the specification, contractual requirements, and EMMP. The SO should also:

- Communicate the requirements of this plan to all staffs, Contractors and sub-contractors
- Monitor all staffs, Contractor's and sub-contractor's compliance with contract specifications and regulatory requirements, including the implementation of the environmental mitigation and monitoring measures and ensure their effectiveness, and other aspects of the environmental audit program;
- Coordinate with the Project's EM/ECO to monitor and participate in the implementation of the environmental audit program, and ensure that the requirements in the environmental audit program are correctly followed;
- Implement measures to reduce impacts where emission/discharge levels are exceeded;
- Coordinate with the Project Owner and RTO for submission of environmental audit reports;
- Carry out any complaint investigations with PRO per Section 8.8;
- Resolve any non-compliance issues; and
- Promote environmental awareness and responsibility and lead by example.

8.4.4 The Contractor

The term "Contractor" refers to all construction Contractors and sub-contractors working onsite at any time, which also the "Occupier of Construction Site" as defined by NEA. In addition to reporting to the SO, the Contractor should:

- Work under the relevant contract scope, specifications, and other tender conditions;

- Ensure that the roles of RTO, Superintending Officer (SO), Environmental, Health and Safety Officer (EHS Officer), Environmental Control Officer (ECO), Certified Arborist, and Fauna Specialist/s are adequately resourced;
- Participate in the required environmental site audits (via the SO) undertaken by the ECO and undertake any corrective actions;
- Provide up-to-date information and advice to the RTO, SO, ECO, Certified Arborist, and Fauna Specialist/s regarding any work activities which may contribute or continuously create adverse environmental conditions, or any changes to the work plan;
- Implement measures to reduce impacts where emission/discharge levels are exceeded;
- Prepare a detailed contract-specific EMMP, incorporating the relevant mitigation measures and monitoring works recommended in this EIA report and seek technical agencies' approval prior to the commencement of any works. This detailed EMMP shall include, as a minimum, a Standard Operating Procedure (SOP) detailing:
 - Handling and storage of hazardous chemicals;
 - Biodiversity management plan;
 - Individual environmental management plans as detailed in the NEA's SHE Specifications (air, vector, waste, noise, water pollution management plans);
 - Monitoring plans (including but not limited to ecology and water pollution);
 - Existing legislation and environmental best practices to be implemented; and
 - Contingency planning during emergency situations.

8.4.5 The Environmental Control Officer (ECO)

The Environmental Control Officer (ECO) Scheme was launched by NEA on 1 April 2000 to advocate good environmental practices within construction sites. Under the Environmental Public Health Act (EPHA), a part-time ECO working at least 15hr/week is required for construction sites with contract sum of between \$10 million and \$50 million, whereas a full-time ECO working at least 40hr/week must be engaged by construction sites with contract sum exceeding \$50 million.

The main role of a registered ECO is to advise the Occupier of the construction site on what needs to be done, which include advising construction site's Contractors on environmental remediation measures, facilitating compliance with the environmental laws, carrying out site inspections and engagement of stakeholders for environmental lapses, as well as educating workers on maintaining good environmental health standards. NEA has also specified that the role of ECO(s) in general would comprise the following aspects:

- Disease-bearing insects and rodents;
- Proper disposal of construction waste/ marine clay;
- Noise, air and water pollution;
- Earth littering;
- Siltation of drains;
- Food hygiene in on-site canteens (if any);
- Proper maintenance of septic tank(s)/ holding tank(s), chemical/ portable toilet(s) and other sanitary facilities; and
- Any other environmental health matters.

The registered ECO(s) shall be employed by the Occupier of the construction site (the Contractor) but may not be in any way as an associated body of the Contractor, the SO, or the Project's SHE team.

8.4.6 The Environmental, Health and Safety Officer (EHS Officer)

The Environmental, Health and Safety Officer is responsible for the overall environmental, health and safety during the construction phase of the Project. With respect to the EMMP, their duty is to:

- Carry out monitoring of environmental parameters and conduct laboratory analysis;
- Conduct regular site inspections, report monitoring results, and audit environmental performance as required in the EMMP;
- Coordinate with the SO and ECO regarding equipment, locations, and schedule of monitoring and auditing works;
- Analyse environmental monitoring data and audit findings, review the adequacy of implementation of mitigation measures, identify adverse environmental impacts, and liaise with the SO and ECO;
- Formulate and implement the environmental audit program and carry out regular site audits against the Contractor's site practices, equipment and work methodologies with respect to pollution control and environmental mitigation, and effect proactive actions to pre-empt problems in coordination with the SO and ECO;
- Monitor compliance with conditions in the EMMP, relevant environmental protection, pollution prevention and control regulations and contract specifications; and
- Report the results of the environmental monitoring program, and any required changes to meet the requirements of the EMMP and legal obligations to the SO and ECO in a timely manner.

8.4.7 Arborist, Floral Specialist and Fauna Specialist

These roles play an important part of the construction process with respect to management of flora and fauna. A Certified Arborist and flora specialist are required to monitor and manage all matters related to the adequate and successful conservation of trees and flora within and adjacent to the contract boundary. Fauna specialists are required for regular fauna monitoring during the construction period and to conduct tree-felling inspections and respond to any fauna incidents/rescue where required. A detailed list of the responsibilities for each role is provided in Section 8.9.

8.5 Roles and Responsibilities of the EMMP for the Operational Phase

8.5.1 Technical Agencies

Consultation and engagement with the technical agencies (e.g. NParks, PUB, NEA, etc) may be required if there are any major environmental concerns affecting their property, land boundary and/or related to the respective scope of responsibilities, or when inputs from technical agencies are necessary in addressing any major public complaints due to environmental incidents arising during the operational phase (if any) of this Project.

8.5.2 Project Owner

The developer/ developing agent is responsible for overseeing and managing the environmental monitoring detailed in the EMMP for the operational phase. The developer/ developing agent is required to:

- Ensure resources and appropriate personnel are available to achieve the requirements of the EMMP;
- Provide leadership in the implementation of the EMMP;

- Ensure all environmental incidents and near misses are promptly investigated and reported;
- Resolve any non-compliance issues;
- Record, respond to, and action any complaints from members of the public, if any, with inputs from the Technical Agencies, if required; and
- Reporting to the Technical Agencies and the developer/ developing agent regarding implementation of the EMMP.

8.5.3 Environmental Health and Safety Officer (or Equivalent)

The Environmental Health and Safety (EHS) officer will be appointed by the developer/ developing agent and is responsible for the overall environmental, health and safety during the operational phase of the project. With respect to the EMMP, the EHS Officer is required to:

- Carry out monitoring of environmental parameters and conduct any required laboratory analysis;
- Conduct site inspections, report monitoring results, and coordinate environmental auditing as stipulated in the EMMP;
- Coordinate with the developer regarding equipment, locations, and schedule of monitoring and auditing works;
- Analyse environmental monitoring data and audit findings, review the adequacy of implementation of mitigation measures, identify adverse environmental impacts, and liaise with the developer;
- Monitor compliance with conditions in the EMMP, relevant environmental protection and control regulations; and
- Report the results of the environmental monitoring program, and any required changes, to meet the requirements of the EMMP to the developer in a timely manner.

8.6 Construction Site Audit

8.6.1 Internal Site Inspection/Audit by ECO

Site surveillance provides a direct means to assess and ensure the Project's environmental protection and pollution control measures are in compliance with the contract specifications and the EMMP. The ECO should inspect the construction activities regularly and routinely to ensure that the appropriate environmental protection and pollution control mitigation measures are properly and timely implemented, based on the EMMP's recommendations. With well-defined pollution control and impact mitigation measures outlined, and a well-established efficient remedial action reporting system, the site inspection is an effective "tool" to ensure acceptable environmental performance at the construction site.

The ECO is responsible to formulate environmental site inspections, deficiencies and the remedial action reporting system, and to carry out the site inspections. After consultation with Project's EHS Officer and SO, the ECO should prepare a procedure for the site inspections, deficiencies, remedial action, and reporting requirements. This documentation shall be agreed to by the RTO and Contractor representative, and approved by the Project Owner within 21 days of the commencement of the construction contract.

Regular site inspections should be carried out at least once weekly for all the work areas during the construction phase. The inspections should cover the onsite environmental situation, pollution control and mitigation measures. Offsite environmental situations, which may be affected by onsite activities, (directly or indirectly) should also be reviewed.

8.6.2 External Environmental Audit by Independent EMMP Consultant

It is suggested for the Project Owner to engage an independent EMMP consultant to perform monthly environmental audit (for all assessed environmental parameters) throughout the construction period.

The external environmental audit exercise would also include the documentation review of on-site monitoring records against the proposed measures and findings in the study. This is to ensure proper implementation of minimum control measures, mitigation measures and EMMP proposed in this report, as well as to identify and/or resolve potential environmental incompliances and potential gaps with the findings in report, if any observed during the audit.

8.7 Operational Phase Audit

During the operation of the project, annual monitoring (minimum frequency) for all environmental parameters should be conducted to ensure that all implemented measures are meeting their intended purpose, and that any potential changes in project conditions such as funicular maintenance issues, increased traffic, track lighting, etc are not having an adverse impact over and above the impacts identified in this assessment. A log tracking all maintenance procedures of equipment and carrying out of audits should be maintained by the Project Owner and the EHS Officer.

A minimum of annual monitoring periods also enables the Project Owner and EHS Officer to address any potential issues, not originally identified during the current impact assessment, that may arise during the course of the project. In this instance, the Project Owner should consider the impacts and, in consultation with the Technical Agencies and qualified professionals, develop measures to mitigate any identified impacts.

Meanwhile, it is suggested for the Project Owner to engage an independent EMMP consultant to perform monthly environmental audit in parallel to the EMMP implementation. This is to inspect the effectiveness of EMMP implementation during operational phase.

8.8 Complaint Handling

The Public Relation Officer (PRO) is responsible for handling complaints and managing feedback and investigative work. The PRO shall be supported by the Project Owner, ECO, Contractor representatives, and any other relevant party.

8.8.1 Construction Phase

During the construction phase, upon receipt of complaints, the PRO should undertake the following procedures:

- Log the complaint and record the date when the complaint is received onto the complaint database and inform the Project Owner, SO, and EHS Officer immediately;
- Investigate the complaint with the ECO to determine its validity and assess whether the source of the problem is due to construction works;
- If a complaint is valid and due to construction works, liaise with the ECO and EHS Officer on the mitigation measures and seek agreement from SO;
- Review the current situation and the ECO's and SO's implementation of the mitigation measures;
- Engage the ECO to undertake additional monitoring and auditing to verify the complaint if necessary. Ensure that any valid reasons for complaints do not re-occur by revising the work methods, procedures, machines and/or equipment, etc.;
- Submit a complaint report (as well as the implementation of mitigation measures and the effectiveness of the mitigation measures as advised by the ECO) to the Project Owner, RTO and the SO; and
- Log a record of the complaint, investigation, follow-up actions and the results in the environmental audit reports.

The ECO, EHS Officer, and SO should provide all the necessary information and assistance to the PRO in order to complete the complaint investigation. Following the investigation, the Contractor should promptly undertake the mitigation measures. The PRO and SO should ensure that the measures have been appropriately implemented. The Contractor, RTO, and SO should also be responsible for the reporting of complaint investigation results and

followed up actions to the Project Owner. The complaint investigation report and corrective action plan should be prepared and approved by NParks and/or other relevant Authorities within 24 hours upon receipt of complaints.

8.8.2 Operational Phase

During the operational phase, upon receipt of complaints, the PRO should undertake the following procedures:

- Log the complaint and record the date when the complaint is received onto the complaint database and inform the Project Owner and EHS Officer immediately;
- Investigate the complaint with the ECO to determine its validity and assess whether the source of the problem is due to construction works;
- If a complaint is valid and due to construction works, liaise with the ECO and EHS Officer on the mitigation measures and seek agreement from SO;
- Review the current situation and the ECO's and SO's implementation of the mitigation measures;
- Engage the ECO to undertake additional monitoring and auditing to verify the complaint if necessary. Ensure that any valid reasons for complaints do not re-occur by revising the work methods, procedures, machines and/or equipment, etc.;
- Submit a complaint report (as well as the implementation of mitigation measures and the effectiveness of the mitigation measures as advised by the ECO) to the Project Owner, RTO and the SO; and
- Log a record of the complaint, investigation, follow-up actions and the results in the environmental audit reports.

The PRO should work with the Project Owner and EHS Officer to gather all the necessary information and resources necessary to complete a complaint investigation. Following the investigation, the Project Manager and EHS Officer to undertake appropriate mitigation measures. Follow-up is required by the PRO to ensure that the mitigation measures have been appropriately implemented. The complaint investigation report and corrective action plan should be prepared and approved by NParks and/or other relevant Authorities within 24 hr upon receipt of complaints.

8.9 Biodiversity Monitoring Program Requirements

At the construction phase, EMMP for both flora and fauna are essential in minimising and managing construction impacts.

8.9.1 Construction Phase

8.9.1.1 Flora Monitoring Programme

The flora monitoring aims to identify impacts arising from the construction to vegetation and habitats, such as tree health, unauthorised and/or excessive vegetation removal, edge effects, habitat degradation from soil erosion, and rubbish dumping. Mitigation measures to address these impacts should be provided where necessary.

Flora Monitoring Programme should include the following works:

- Monthly flora inspections shall be conducted within the worksite boundary and in forested areas adjacent to the worksite up to 15 m from the hoarding.
- Identification of any unauthorised removal of flora within areas of conservation or beyond the demarcated development worksite (Figure 8-3).
- Identification of direct/indirect impacts to sensitive vegetation and habitats. Such impacts include soil erosion and degradation that have resulted from construction activities, and unauthorised dumping of waste material, construction debris or oil/chemical leakage.

- Identification of forest edge effects and recommendation of mitigation measures where necessary.
- Assessment of the status of invasive flora species and weeds and recommendation to remove them where necessary.
- Inspection of areas cleared of weeds to detect any seedlings of invasive species.
- Monitoring of the health of all retained and planted flora, including identification of diseases and recommendations for treatment.



Figure 8-3 Monitoring of vegetation and trees along the hoarding line for unauthorised vegetation clearance and forest edge effects

8.9.1.2 Flora Management Programme

The flora management programme aims to manage all matters related to the adequate and successful conservation of trees and vegetation within and adjacent to the contract boundary (up to 15-m from the contract boundary).

Flora Management Programme should include the following works:

- Verification and Review of Footprints for Hoarding, Access Roads and Soil Investigation Works
 - After the worksite hoarding has been installed, the Flora Specialist shall conduct an inspection to verify that the footprint is as proposed, and that no excessive vegetation and tree removal has occurred because of deviations in the hoarding alignment.
 - The Flora Specialist shall review the proposed locations for the soil investigation works and the alignment of the construction access roads with the Client/Contractor. Feasible alternatives, if possible, shall be proposed to minimise vegetation and tree clearance.
- Weed and Invasive Species Management
 - Weeds and invasive species shall be cleared from the Project Site progressively and shall be separated and transported to an appropriate disposal location. Transport shall occur within a covered vehicle to ensure seed/vegetative matter does not dislodge. All vegetative matter and seeds will be rendered inert at the disposal location through incineration at a licensed waste disposal facility. The Project Site shall be carefully cleared of all remaining vegetative matter from

the weeds/invasive species. Herbicides may be used to render any stumps/root systems inert. The cleared area shall be inspected monthly to detect any seedlings of invasive species. These seedlings shall be killed using approved herbicides or removed by hand weeding. Any seedlings or vegetative matter that may sprout will be disposed of at a licensed waste management facility.

- Specific measures shall be undertaken to control and manage flora species within the Project area that have been identified to be invasive (i.e., *Spathodea campanulata*, *Cecropia pachystachya*, *Falcataria moluccana*). The Ecologist shall be consulted when managing *Falcataria moluccana* groves as tall trees may serve as nesting sites for birds of prey. The Ecologist shall also be consulted for other weed and invasive species that may also provide important foraging resources. Material imported into the Project area shall be checked for contamination from weeds/invasive species seeds/vegetative matter at source. This is particularly important for imported building materials, such as clay and soil. Source site shall be inspected to determine presence of weeds/invasive species. Where weeds or invasive species are identified, alternative supply sources or decontamination shall occur before the material is transported to site.
- Infill Planting Palette and Plant Salvaging for Reforestation and Landscaping
 - The planting palette including all flora and grasses used for reforestation and other landscape planting shall be from native indigenous stock or non-native species that are not listed as weeds or invasive species or have a low seeding rate.
 - All trees transplanted into the Project area shall have local provenance or will be from within the Johor region for all SRDB and IUCN listed species. Other species shall be obtained within the larger Sunda region. Due diligence shall be conducted on suppliers to ensure that the trees are obtained by legal means and are able to be exported/imported to Singapore. All imported trees shall be inspected and/or undergo quarantine if required to reduce the chance of transmission of weeds and soil pathogens.
 - The success of planting within landscape features shall be monitored. Where a planting strategy is not working, an alternative planting strategy shall be developed suitable for the location. Temporary measures shall be employed to reduce stress on planted individuals. The removal of sources of stress (such as dust) may also be required. If disease outbreaks are present, methods shall be used to control the outbreak or remove the diseased individual.
 - The flora specialist shall also identify other plant material, including ferns, epiphytes, orchids, shrubs, grasses, etc. that are of conservation value and work with NParks for the extraction of these plants by NParks to other sites.
 - The flora specialist shall formulate a salvaging protocol in consultation with NParks if salvaging of plant material is being carried out on site.

The flora specialists engaged should meet the expected qualifications as described in Section 8.4.7.

Subsequently, if there is a need for the following works stated below, an arborist should be engaged and should meet the expected qualifications as described in Section 8.4.7.

- Sapling Harvesting
 - Viable saplings and conservation significant trees that are suitable for harvesting shall be identified by the Arborist. Saplings or trees suitable for transplanting should:
 - Exhibit good physiological health and vigour
 - Have no structural defects
 - Have good branch form
 - The root ball size to be extracted shall be based on the girth of the saplings or trees to be harvested as specified in Table 8-1.
 - Prior to transplanting, dead branches and climbers shall be cleared from the plant and canopy load and spread will be reduced where necessary, in consultation with the Arborist.
 - Manual trenching shall be carried out to determine the shape and size of root ball to be extracted. Where possible, feeder roots shall be retained without cutting.

- The root ball shall be burlapped with cellophane sheet to reduce desiccation effects. When directed by the Flora specialist or Arborist, leaves of the canopy may also need to be enclosed and covered by cellophane or clear plastic bags.
- The root ball shall be secured to the trunk to reduce risk of root ball disintegrating.
- When handling/carrying the plant, care shall be taken not to damage any vegetative parts.
- Tree Transplanting
 - Where trees and vegetation are moved or translocated within the Project area, the Arborist shall review the method statement proposed by the tree transplanting contractor and advise on additional recommendations necessary to ensure the tree's health during transplanting. The transplanting contract shall ensure in their best effort, intact and secured root balls at the point of extraction, during the lifting processes and during the installation at the receiving site. The transplant effort shall be documented for each individual tree to show intact root balls at all the stages mentioned. Transplanted trees shall be managed through adequate watering and monitoring of their health to ensure their long-term survival. Advice shall be sought from the Arborist if the tree exhibit signs of stress, e.g. peeling bark, withered leaves.
- Site Clearance and Tree Felling
 - The Contractor's method statements for site clearance, tree felling and setting up of TPZ shall be reviewed by the Arborist to ensure compliance to the specifications. The site clearance and tree removal method statements shall consider directional felling methods with a hinge and back cut. Trees shall not be removed by pushing with an excavator or other heavy machinery. Cranes shall be deployed to offset the tension of trunks in the direction of the drop. Interlocking canopy branches shall be pruned prior to tree felling.
 - In cases where design changes may affect additional trees or the retained trees, the Arborist shall work with the structural engineers and recommend solutions that will meet NParks guidelines.
 - Whenever reasonable and practicable, cleared vegetation at sloped areas shall be covered with mulch or with 100% biodegradable fauna-friendly ECBs to control erosion of exposed soil. Closed turving to the exposed areas where possible and maintain proper storage of soil stockpiles to stabilise surfaces and minimise re-entrainment of dust and potential for erosion of waste spoil to watercourses.
 - Clearance activities on-site shall not occur during rainfall or when storm events are forecast to occur within the vicinity to protect forest edge from wind throw. Where forest edges are exposed to wind, temporary measures (e.g., additional hoarding) shall be discussed with the Arborist, and put in place to protect the forest edge during storm events.
 - During site clearance, care will be taken when removing trees in riparian zones to reduce impacts to the bed and banks of waterways.
 - Where practicable, saplings, seeds and seed banks will be retained within the soil profiles for use in forest restoration.
 - Horticultural waste shall be removed on the same day. This is essential to reduce risk of fauna taking refuge within the cleared waste if left overnight.
- Tree Maintenance and Care
 - Where disease outbreaks are identified, the Arborist and/or Flora Specialist shall advise measures to manage them. Measures can include using selected insecticides/fungicides to control outbreaks; reduction of stressors (dust, water, etc.). The plant may be removed or quarantined if it poses a threat to surrounding individuals.
 - Where forest edges are exposed following site clearance and where impacts to vegetation are evident (e.g., vegetation shows signs of drying out), additional watering shall be carried out to improve moisture differentials around forest edges.
 - The use of herbicides, pesticide shall be minimised. If herbicides or pesticides are used within the Project area, techniques that limit spray or non-target spray drift shall be used. These techniques include but are not limited to cut and paint techniques and drilling injection. All use of herbicides

and pesticides shall be conducted in accordance with the relevant Material Safety Data Sheet (MSDS). Any incidents of off label use, spillage or damage to non-target species shall be reported and investigated.

- When the site experiences seven continuous days without rainfall, the Contractor shall carry out additional watering of conserved trees within the TPZs and at the forest edge (up to 10 m) around the development boundary.
- Post heavy rainfall, any snapped hanging branches that pose imminent hazards to workers within the site should be removed immediately

Table 8-1 Minimum root ball diameter to girth requirements

Girth (m)	Minimum root ball diameter to extract (m)
<0.1	0.4
0.1–0.2	0.6
0.2–0.3	0.8
0.3–0.4	1.2
0.4–0.5	1.5
>0.5	To be determined by Arborist

Additionally, the Contractor should fulfil the following:

- The Contractor and the attending arborist shall complete the 'Verification of Tree Protection Checklist' prior to the start of site clearance (refer to Appendix I: Annex A); and
- The Contractor shall instil discipline and raise awareness amongst all personnel on measures and mitigations to prevent damage to retained and protected trees throughout construction by including reminders on tree conservation guidelines within their daily toolbox briefings to workers and crane/excavator operators.

8.9.1.3 Fauna Monitoring Programme

Fauna monitoring surveys should comprise of monthly diurnal surveys beginning one month prior to construction and ending two months after reinstatement.

Faunistic surveys are recommended to be conducted along terrestrial sampling routes and aquatic sampling points as conducted during baseline, and should target the following fauna groups: 1) butterflies, 2) odonates (damselflies and dragonflies), 3) amphibians, 4) reptiles, 5) birds, 6) mammals (including bats), 7) fishes, 8) decapod crustaceans, 9) molluscs, and 10) xiphosurids (horseshoe crabs). Comparison of species presence can be made with the baseline studies, where appropriate, to provide an indication of the changes in fauna diversity.

The methodology for the faunistic surveys should closely follow that implemented in the biodiversity baseline studies, so as to ensure that the data collected can be used to compare against the baseline data.

Further details of the surveys should be determined in consultation with NParks and should take into account construction phases, final construction footprint, final development hoarding plan, and baseline studies.

8.9.1.4 Fauna Management Programme

Fauna management will consist of managing fauna within and around all designated work areas. It consists of (1) monthly site inspections, (2) pre-site clearance inspections, (3) biodiversity awareness training, and (4) fauna response plan in event of animal encounters. The objectives of fauna management are to (1) minimise negative impacts to fauna, particularly to species of conservation significance and (2) prevent human wildlife conflicts.

The following should be inspected for during monthly fauna site inspections (Figure 8-4):

- Visual inspection of sensitive habitats in the vicinity (e.g., mangrove forest and Ponds) to determine if the construction has damaged or affected them
- Presence of trapped/injured/dead fauna

- Potential fauna entrapments (e.g., ECBs, TPZs, pits, drains, ponds, trenches, tanks)
- Gaps in hoarding that may allow entry of ground-dwelling fauna
- Improperly disposed/stored food and food packaging
- Reporting and documentation of all findings and recommendations (Appendix J)



Figure 8-4 Photographs showing monthly fauna monitoring and inspection on-site

Pre-site Clearance Fauna Inspection

Part of pre-site clearance involves pre-felling inspections. This is to minimize fauna injury and mortality during tree felling and vegetation clearance. Site clearance should be executed outside of the key bird breeding season (March to July) where possible. Refer to Figure 8-5 for pre-felling inspection protocol, and Appendix K for Pre-felling Inspection Form.

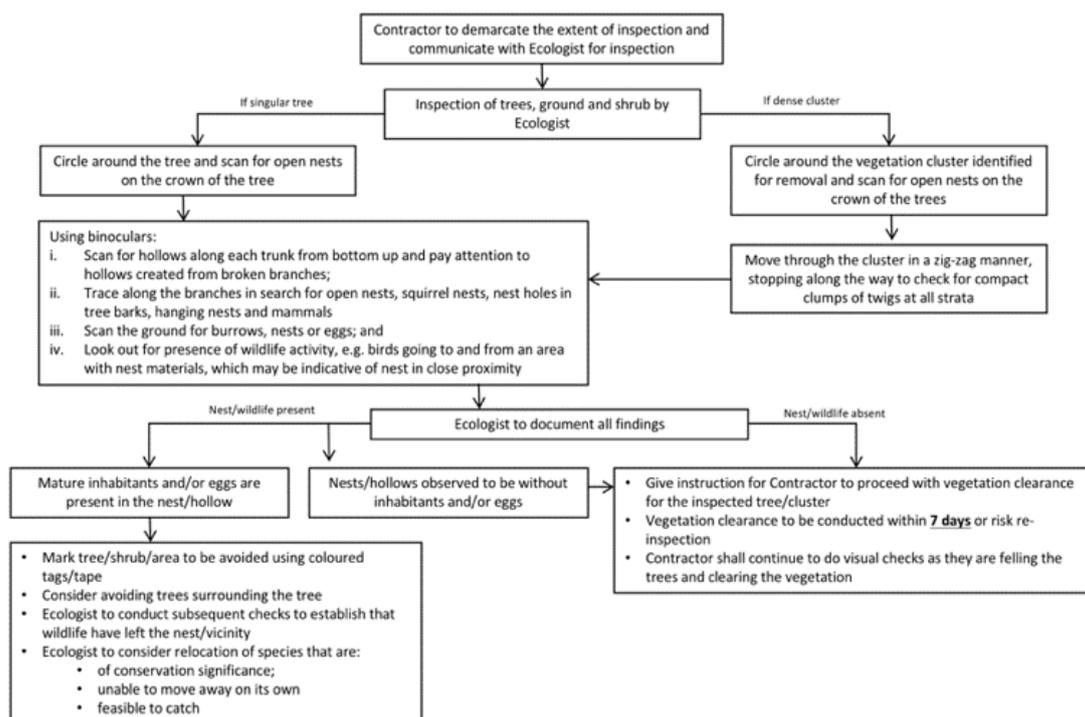

Figure 8-5 Example of pre-felling inspection protocol

Biodiversity Awareness Training

The Ecologist shall conduct toolbox briefings on biodiversity awareness to inform site personnel of but not limited to the following:

- Ecological value of the site and its surrounding habitats
- Types of fauna present
- Biodiversity protection strategies
- Site personnel's responsibilities towards biodiversity
- How to respond to fauna encounters
- No feeding of wildlife
- Inspection of trees before felling

All site personnel shall undergo biodiversity awareness training prior to commencing work at on-site, and regularly (every six months) throughout the duration of the construction. Documentation of such trainings and briefings shall be maintained.

Fauna Response Plan

The Fauna Response Plan should be formulated by an Ecologist and enacted when a trapped/injured/dead/dangerous animal is encountered around or within the worksite. The objective of the wildlife response plan is to minimise animal injury and mortality by responding appropriately to the different scenarios in Figure 8-7. The plan should also detail the chain of command, personnel involved, and the roles of the various stakeholders. This should be emphasized during the toolbox briefings. All wildlife encounters are to be documented within 24 hours using the Wildlife Incident Form (Appendix L).

Where species of conservation significance are affected by the development, relocation works should be planned (e.g., bamboo bats). Where fauna is trapped on-site, options should be explored to remove them from site (e.g., partitioning worksite, use of one-way exit door) (Figure 8-6).

In scenarios where certain animal groups are encountered around or within the worksite, external specialists may be contacted to handle the animal. These scenarios are shown below:

- For encounters with snakes that require relocation/handling, a snake specialist should be contacted.
- For animal carcasses that require disposal, an animal carcass disposal service should be contacted.
- For injured animals that require medical attention, a veterinarian should be contacted.



Figure 8-6 Example of one-way flap door to allow fauna to exit independently.

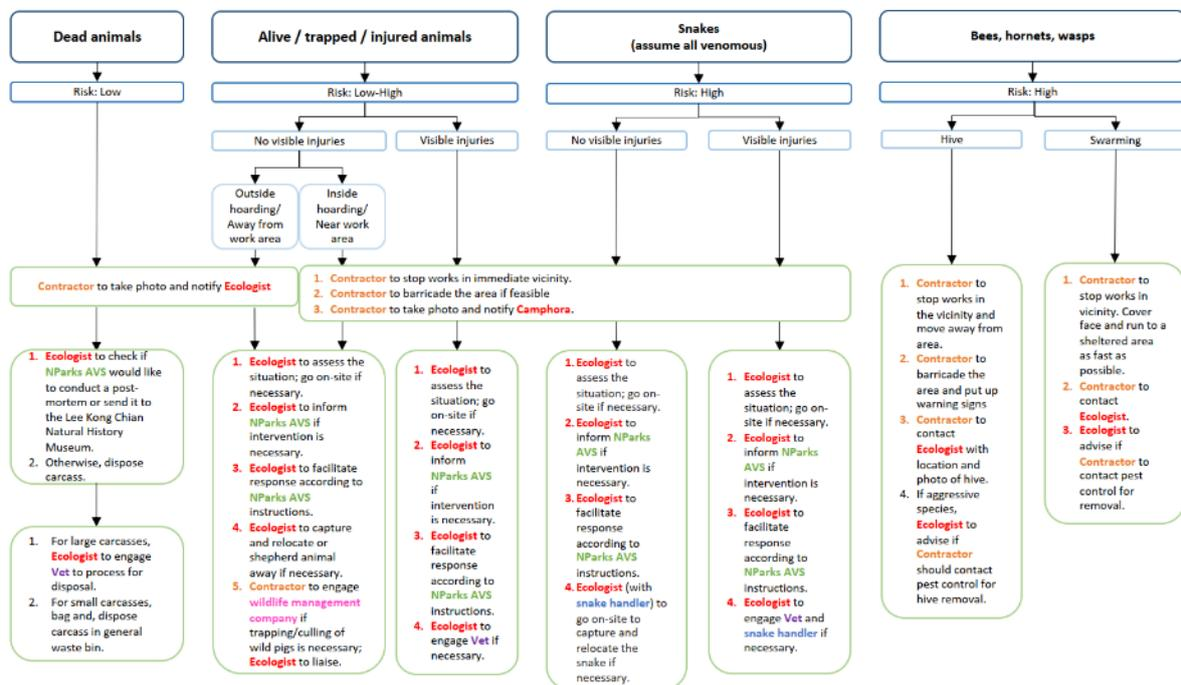

Figure 8-7 A flow chart of wildlife response plan.

8.9.2 Operational Phase

At the operational phase, it is important to monitor the flora and fauna for at least a year into the operational phase. This will help to determine the effectiveness of mitigation measures proposed during the design phase, identify and rectify biodiversity issues that arise due to operational activities.

8.9.2.1 Flora Monitoring Programme

The flora monitoring aims to identify impacts arising from operational activities to the Study Area, and rectify issues when identified. The programme should include the following:

- Assess impact of operational activities on the physiological health and structural stability of vegetation and trees at proximity to the development;
- Determine whether there has been excessive and unauthorized removal of vegetation and trees beyond the development boundary;
- Monitor and assess potential edge effects (e.g., predictable failures, accelerated growth of climbers on canopy, change in species composition at the edge) within vegetation adjacent to the development;
- Determine if there was unauthorized dumping of rubbish (e.g., food materials), oil/chemical leakage that may contaminate soil and waterbodies.

8.9.2.2 Fauna Monitoring Programme

The fauna monitoring aims to identify impacts arising from operational activities to fauna residing within the Study Area, and rectify issues when identified. The programme should include faunistic surveys. Faunistic surveys are recommended to be conducted along terrestrial sampling routes and aquatic sampling points, and should target the following fauna groups: 1) butterflies, 2) odonates (damselflies and dragonflies), 3) amphibians, 4) reptiles, 5) birds, 6) mammals (including bats), 7) fishes, 8) decapod crustaceans, 9) molluscs, and 10) xiphosurids (horseshoe crabs). Comparison of species presence can be made with the baseline studies and construction phase monitoring studies, where appropriate, to provide an indication of the changes in fauna diversity. The methodology for the faunistic surveys should closely follow that implemented for the EBS, so as to ensure that the data collected can be used for comparison.

8.10 Marine Water Monitoring Program Requirements

8.10.1 Construction Phase

In order to ensure that procedures are followed appropriately, the construction phase of the Project should be accompanied by an EMMP. Water quality monitoring is essential as discharge of excess contaminants, especially pH, nutrients and heavy metals, may lead to severe consequences (e.g. algae blooms).

There may be wastewater discharges generated from the planned works during the construction phase, therefore monitoring of discharge water is recommended to be undertaken to complement water quality results to assure compliance with the relevant standards. Water quality parameters and specifications should refer to this EIA for guidance. Monthly audits of the site should also be carried out by an EMMP consultant. The water quality at the two (2) proposed monitoring locations (refer to Figure 8-8) should also be recorded and compared with the ASEAN Marine Water Quality Criteria as listed in Table 7-4 to make sure the water quality will not be impact by the operational activities.

Recommended standards/guidelines are shown in Table 8-2 and Table 8-3.

Table 8-2 Recommended standards and guidelines for water quality monitoring.

Aspect	Standard and Guideline
Discharge Points	NEA's Allowable Limits for Trade Effluent Discharge into Watercourse
Marine Water Quality	ASEAN Marine Water Quality Criteria

Table 8-3 Recommended water quality specifications and parameters during construction phase.

Aspect	Test	Parameter	Monitoring Recommendation and Frequency	
Discharge Points*	In-situ	Temperature	<ul style="list-style-type: none"> Online real-time monitoring for turbidity at known discharge points* throughout the construction period. The exact locations are to be defined by contractor during the construction period. Monthly monitoring for temperature and pH at all the discharge point locations throughout the construction period. 	
		pH		
		Turbidity		
Marine Water Quality	In-situ	Temperature		<ul style="list-style-type: none"> Monthly monitoring for all in-situ parameters at the proposed monitoring locations (refer to Figure 8-8) throughout the construction period.
		pH		
		Salinity		
		Conductivity		
		Turbidity		
		Dissolved Oxygen (DO)		
	Total Dissolved Solids (TDS)			
Ex-situ	Total Suspended Solids (TSS)	<ul style="list-style-type: none"> Monthly monitoring for all the ex-situ parameters at the proposed monitoring 		
	Total Nitrogen (TN)			

Aspect	Test	Parameter	Monitoring Recommendation and Frequency
		Ammoniacal Nitrogen (NH ₄ -N)	locations (refer to Figure 8-8) throughout the construction period.
		Nitrates (NO ₃ -N)	
		Nitrite (NO ₂ -N)	
		Total Phosphorus (TP)	
		Orthophosphate (PO ₄ -P)	
		Arsenic (As)	
		Nickel (Ni)	
		Zinc (Zn)	
		Mercury (Hg)	
		Cadmium (Cd)	
		Chromium (VI) (Cr VI)	
		Copper (Cu)	
		Lead (Pb)	
		Tributyltin	
		Cyanide (CN ⁻)	
		Free Chlorine	
		Total Phenol	
		Biological Oxygen Demand (BOD ₅)	
		Oil & Grease (Total)	
		Faecal Coliform	
		<i>Enterococcus</i>	

Note:

* Discharge points refer to immediate areas (i.e. surrounding waters) just outside of the silt curtains. As the filling works are likely to commence near the northern-most edge of the pond before moving southwards during the construction phase, the silt curtains that are used to surrounding the working areas would also likely change based on the work progress. Hence, the real-time turbidity monitoring at these discharge points are expected to move along to newly defined working areas as well.



**SOUTHEAST COAST OF
PULAU UBIN**



Legend

- Proposed water quality monitoring locations
- ▭ Sungei Durian Ponds Project Site

N

Rev.	Date	By	Description	Chk'd	App'd
-	AUG 2022	CQA	EIA Report	NHT	JAG

Qualified Person Endorsement :
NA

NParks Endorsement : NA

Consultant : **AECOM**

Project Title :
**CONTRACT NPARKS/N/39/2017
CONSULTANCY SERVICES FOR SHORELINE
WORKS IN PULAU UBIN
(MANGROVE RESTORATION OF
SUNGEI DURIAN PONDS)**

Designed CQA	Checked NHT	Approved JAG
Drawn CQA	Date AUG 2022	

Client: 

Figure Title :
**Proposed water quality monitoring locations
during construction and operational phases**

Figure No. : 8-8	Rev. : -	Sheet : 1 of 1
CAD File Name : NA		A3

8.10.2 Operational Phase

The operational phase of the projects should be accompanied by an EMMP to ensure the proposed development will have minor impact on the surrounding waterbodies. Water quality monitoring is essential as discharge of excess contaminants, especially pH and suspended solids may lead to severe consequences (e.g. water with less clearance) due to the operational activities. It was recommended to monitor their water quality during the first three (3) months of operational period to ensure minor operational impacts on their water quality. The water quality at the two (2) proposed monitoring locations (refer to Figure 8-8) should also be recorded and compared with the ASEAN Marine Water Quality Criteria as listed in Table 7-4 to make sure the water quality will not be impact by the operational activities.

Table 8-4 Recommended water quality specifications and parameters during operational phase.

Test	Parameter	Monitoring Recommendation and Frequency
In-situ	Temperature	<ul style="list-style-type: none"> Monthly monitoring for all the in-situ parameters at the proposed monitoring locations (refer to Figure 8-8), during the first three (3) months of the operational period.
	pH	
	Salinity	
	Conductivity	
	Turbidity	
	Dissolved Oxygen (DO)	
	Total Dissolved Solids (TDS)	
Ex-situ	Total Suspended Solids (TSS)	<ul style="list-style-type: none"> Monthly monitoring for all the ex-situ parameters at the proposed monitoring locations (refer to Figure 8-8), during the first three (3) months of the operational period.
	Total Nitrogen (TN)	
	Ammoniacal Nitrogen (NH ₄ -N)	
	Nitrates (NO ₃ -N)	
	Nitrite (NO ₂ -N)	
	Total Phosphorus (TP)	
	Orthophosphate (PO ₄ -P)	
	Arsenic (As)	
	Nickel (Ni)	
	Zinc (Zn)	
	Mercury (Hg)	
	Cadmium (Cd)	
	Chromium (VI)	
	Copper (Cu)	
	Lead (Pb)	
	Tributyltin	
	Cyanide (CN ⁻)	
Free Chlorine		
Total Phenol		

Test	Parameter	Monitoring Recommendation and Frequency
	Biological Oxygen Demand (BOD ₅)	
	Oil & Grease (Total)	
	Faecal Coliform	
	<i>Enterococcus</i>	

Monthly audit on the site should be carried out by EMMP consultant during the first three (3) months of operation period.

8.11 Proposed EMMP

The framework for the proposed EMMP is detailed below; however, it is important to note that this is not an exhaustive list of potential impacts, monitoring requirements, and triggers. This EMMP is intended to be a living document and should be reviewed thoroughly by the Client/ Project Owner and the Contractor (CT) prior to implementation. Development of the following inputs, that have not been addressed in this report, by the CT are also required, including but not limited to:

- Stakeholder Communications Plan;
- Air Pollution Control Plan;
- Site log for all monitoring activities and complaints;
- Construction Logistics Plan;
- Standard Operating Procedures for processes identified in Table 8-5 and Table 8-6 below;
- Emergency Response Plan;
- Inventory of wastewater streams;
- Training protocols for staff, where appropriate; and
- Maintenance and Audit Schedules.

8.11.1 Construction Phase

The EMMP for construction phase of the project is described in Table 8-5 below.

Table 8-5 Proposed environmental monitoring and management plan for the construction phase.

Environmental Parameter	Environmental Issue	Minimum Control Measures	Mitigation Measures	Monitoring Parameter	Monitoring Locations	Recommended Frequency of Monitoring	Monthly Reporting	Site Responsibility	Triggers ^{4,5}
Biodiversity	Minimisation of construction impacts to flora/vegetation	<ul style="list-style-type: none"> Mark out site boundary Set up Tree Protection Zones (TPZs) around trees or other plant specimens to be retained within the worksites Tag trees (with or without TPZs) meant to be protected or transplanted to avoid accidental removal 	<ul style="list-style-type: none"> Record locations, species and quantity of transplant candidates that are affected by construction 	Flora and Arboriculture	Within development boundary	Prior to site clearance	-	CT, ECO, Floral Specialist	N/A
		<ul style="list-style-type: none"> Establishment of TPZs Inspect the integrity of the TPZ hoarding Assess tree physiological health and vigour Check for mechanical damage on trees that may impair stability Review method statements of construction works in proximity to retained trees Implement soil erosion control measures as soon as vegetation has been removed and soil is exposed 	<ul style="list-style-type: none"> Identify excessive or unauthorized tree removal Identify trees that require management and maintenance such as tree care and pruning Determine if there are any unauthorized removal of flora within areas of conservation (if any) or beyond the demarcated worksite Identify areas with soil erosion and degradation that have resulted from construction activities Determine if there are unauthorized dumping of waste material, construction debris or oil/chemical leakage that may contaminate the soil and waterbodies, and/or be detrimental to the vegetation Identify areas that are responding poorly due to the development impacts 		Within development boundary and 15m beyond hoarding line	Monthly for duration of construction	To be included in monthly report	CT, ECO, Floral Specialist, Arborist	
	Minimisation of construction impacts to fauna	-	<ul style="list-style-type: none"> Implementation of pre-site clearance fauna inspection 	Fauna	Within development boundary	Prior to site clearance	To be included in monthly report	CT, ECO, Ecologist	
		<ul style="list-style-type: none"> Ensure proper storage of machineries likely to leech harmful chemicals and fuel-powered equipment; Store the aforementioned equipment away from waterbodies and/or sensitive habitats. 	<ul style="list-style-type: none"> Assess habitat quality (e.g., water quality, excessive vegetation removal); Check for presence of trapped/injured/dead fauna, potential fauna entrapments and gaps in site hoarding; and Conduct toolbox briefings on biodiversity awareness. 		Within development boundary	Monthly for duration of construction	To be included in monthly reports.	CT, ECO, Ecologist	
		-	<ul style="list-style-type: none"> Conduct biodiversity survey to monitor construction impacts on fauna activity and presence Recording of number of occurrences of human-wildlife conflict 		Adjacent to development boundary	Monthly for duration of construction	To be included in monthly report	CT, ECO, Ecologist	
Marine Water (including water quality)	<ul style="list-style-type: none"> Solid & Toxic Waste Generation 	<ul style="list-style-type: none"> Development of a Standard Operation Procedure (SOP) for safe handling, transfer, storage and disposal of solid waste; 	<ul style="list-style-type: none"> To use Cage Type Grab Dredger To install double layers of silt curtains surrounding the 	All water quality parameters	Discharge points (defined by contractor during the construction period)	<ul style="list-style-type: none"> Real-time turbidity monitor installed at every discharge point Implementation of CCTV including a SIDS at every discharge outlet to monitor 	To be included in	CT, ECO	Investigation and corrective actions to be taken, when:

⁴ Resident Technical Officer (RTO) and Site Officers (SO, WSHO and ECO) check the Study Area for construction progress and implementation of environmental mitigation measures.

⁵ If there is trigger then all the mitigation and management measures should be audited in detail for compliance and corrective action must be taken in liaison with the Project Owner.

Environmental Parameter	Environmental Issue	Minimum Control Measures	Mitigation Measures	Monitoring Parameter	Monitoring Locations	Recommended Frequency of Monitoring	Monthly Reporting	Site Responsibility	Triggers ^{4,5}
		<ul style="list-style-type: none"> Effective ECM and monitoring implemented as required in the Code of Practice on Surface Water Drainage to ensure that discharge into the stormwater drainage system does not contain TSS in concentrations greater than the prescribed limits under the Sewerage and Drainage (Surface Water Drainage) Regulations; ECM measures include but are not limited to minimisation of formation of bare soil, use of biodegradable erosion control blankets for the coverage of all bare/erodible surfaces, slope stability, concrete cut-off drains, silt fences/traps along the perimeter cut-off drain, turbidity curtains for works adjacent to watercourses, etc.; Implementation of CCTV including SIDS at the public drain to monitor the surface runoff discharges from the sites as per the Public Utilities Board of Singapore's (PUB) circular on Preventing Muddy Waters from the Construction Sites (October 2015); Protection of stockpiles with biodegradable erosion control blanket coverage and proper scheduling of the demolition and earthworks to reduce the quantity of stockpiles to be stored onsite; Provision of side flaps on barges and pontoons when transporting fill material to site via sea to prevent spills during transportation. Provision of enclosed monkey-proof bins and waste disposal facilities cleared up as often as necessary to prevent build-up. Housekeeping checks will be carried out once a day to ensure all litter is cleared from site; Hazardous substances and toxic wastes should be stored on hard stand, under shelter with a kerb around the storage area; All wastes will be disposed only in the designated waste disposal facilities and appropriately separated, i.e. by trained workers to properly sort and label the different types of waste (reusable and recyclable waste, toxic and non-toxic waste, etc.); and Appropriate disposal of any waste listed in the Environmental Public Health (General Waste Collection) Regulations by licensed waste operator/collector. 	working areas when pond filling activities are carried out	identified in Table 8-3.	and proposed marine water quality monitoring locations (refer to Figure 8-8).	the surface run-off discharges from the worksites. <ul style="list-style-type: none"> Monthly water quality monitoring for all discharge points and proposed monitoring locations (refer to Figure 8-8) throughout the construction phase. Intensity of the laboratory analysis will be increased (e.g. fortnightly, weekly) if in-situ measurements and/or monthly laboratory results indicate deterioration in the water quality. Intensified monitoring will be carried out until in-situ measurements and/or laboratory results indicate 'normality'/consistency with earlier monitored conditions; and Daily inspection on perimeter drains to ensure no surface runoff flowing out from the site untreated done by the site officer with monthly audit done by EMMP consultant. 	monthly report		<ul style="list-style-type: none"> The following documentation are found inadequate/missing: <ul style="list-style-type: none"> ECM Plan; Monitoring Log; Training Log; Audit Reports; If the monitored parameters exceed applicable values of either NEA's Allowable Limits for Trade Effluent Discharge into Watercourse or ASEAN Marine Water Quality Criteria as listed in Table 7-4; If the monitored parameters exceed applicable values of criteria as mentioned above or existing baseline conditions in Table 7-4 and Table 7-16 (whichever is higher) at identified sensitive receptors; If complaints are received due to project activities; and If visual non-compliance to any of the minimum control or mitigation measures are observed on-site.
	<ul style="list-style-type: none"> Liquid Effluent and stormwater run-off Generation 	Construction wastewater resulting from construction site: <ul style="list-style-type: none"> A full inventory of all anticipated wastewater streams and volumes should be finalised before the onset of the construction works; No unmanaged discharge of wastewater stream permitted; Reduce, reuse, and recycle hierarchy principle to be applied to wastewater on-site; Regular audits on environmental management procedures will be carried out on-site; No hazardous liquids to be sent to the detention pond/tank (if any); Hazardous wastewater (if any), such as oily water, thinners, solvents, or paints should be stored on hard stand, under shelter with a kerb around the storage area. The wastewater should be removed for treatment and disposal off-site by an approved Waste Management Contractor. Hazardous liquids to be handled as Hazardous Waste; 	N.A.		N.A.				

Environmental Parameter	Environmental Issue	Minimum Control Measures	Mitigation Measures	Monitoring Parameter	Monitoring Locations	Recommended Frequency of Monitoring	Monthly Reporting	Site Responsibility	Triggers ^{4,5}
		<ul style="list-style-type: none"> Containment pond/kerbs will be of impervious material and be designed with sufficient capacity to hold volumes of wastewater produced on-site and potential fire-fighting wastewater. Contractor will seek for comment and approval from relevant authorities (e.g. SCDF and NEA) on the treated wastewater to be used for firefighting purpose; ECM tanks/ponds will be designed in sufficient capacity to hold the turbid stormwater prior to treatment at the ECM facility; Temporary storage volumes should be provided for overflow situations. Temporary storage with sufficient capacity will capture any expected additional volumes to ensure untreated wastewater is not released to marine water unless it complies with Singapore NEA Guidelines on trade effluent discharge concentrations; A responsible person (e.g. ECO) to be assigned to oversee the efficient operation of the containment pond/kerbs where 'Good Housekeeping' practices would be adhered to. Also, the area would be carefully managed to avoid spills, leaks, and odour issues, with the containment pond/kerbs checked at least daily to ensure proper functionality; Daily record volume of wastewater, as well as volumes of sludge and other produced wastes; Contractor will need to seek approval from relevant authorities (i.e. PUB & NEA) as per PUB Sewerage and Drainage (Trade Effluent) Regulations if the wastewater will be disposed to public sewer or NEA's Trade Effluent Discharge Limits to controlled watercourse if the treated trade effluent will be disposed to surface watercourses. If such discharges are not approved, the trade effluent will be stored, treated or recycled on site and finally disposed off-site; The discharge of oil or oily mixtures from the construction site is prohibit. The containment pond/kerbs, as well as wastewater generating areas on-site, to be equipped with spill clean-up kits; Adequate drainage, cut-off drains sump pit, road kerb, piping and toe wall will be designed for channelling of construction process wastewater (e.g. wash water, etc.) and stormwater runoff separately through detailed design for capture and treatment in the containment pond/kerbs. Where applicable (e.g. in the vicinity of liquid storage or refuelling areas), this infrastructure will include oil-water separators to capture inadvertent spills or leaked oils or greases; Implement a construction EMMP and ensure full preparation of associated plans and procedures including the following: <ul style="list-style-type: none"> EMMP to include SOPs, an Emergency Response Plan (ERP), an inventory of wastewater streams, training of staff as well as an inspection, maintenance and audit schedule; and Full development of EMMP Wastewater Management Procedures to include dedicated management and monitoring procedures that covers all eventualities related to the proper operation of the containment pond/kerbs, or any other wastewater discharge location/equipment. Regular and dedicated procedures for the inspection and maintenance of wastewater (i.e. 							

Environmental Parameter	Environmental Issue	Minimum Control Measures	Mitigation Measures	Monitoring Parameter	Monitoring Locations	Recommended Frequency of Monitoring	Monthly Reporting	Site Responsibility	Triggers ^{4,5}
		<p>trade effluent) collection, storage, and treatment infrastructure, such as pipes, oil water separators, silt screens, etc.;</p> <ul style="list-style-type: none"> Regular and dedicated procedures for the management of stormwater collection, settling, testing and eventual discharge of 'clean' water to marine water. This should also include associated measures required to prevent high sediment concentration stormwater drainage to marine water; and A training programme for all on-site workers, including sub-contractors, in relation to their obligations for ensuring proper water quality management; <p>Storage and disposal of domestic liquid wastes:</p> <ul style="list-style-type: none"> Provision of portable toilets and on-site septic tank; Regular cleaning of the portable toilets (if any) and clearing of sanitary waste; Appropriate location of toilet facilities away from any nearby watercourses; Inspections and audits to ascertain the hygienic conditions onsite; The toilet facilities will be placed at least 30 m away from any nearby watercourse; Training of workers on the best practices to contribute in environmental protection; and Appropriate disposal of any waste listed in the Environmental Public Health (General Waste Collection) Regulations by licensed waste operator/collector regardless the wastes to be disposed off-site or discharged to public sewer. <p>Stormwater Runoff Generation:</p> <p><u>Stormwater Quality:</u></p> <ul style="list-style-type: none"> ECM measures include but are not limited to minimisation of formation of bare soil, use of biodegradable erosion control blankets for the coverage of all bare/erodible surfaces, concrete cut-off drains, silt fences/traps along the perimeter cut-off drain, turbidity curtains for works adjacent to marine water; Adequate drainage, piping and/or channelling of stormwater runoff to be assured through detailed design for capture and treatment at ECM tanks/ponds before discharge into marine water; Regular and dedicated procedures for the inspection and maintenance of stormwater collection, storage, and treatment infrastructure, such as pipes, oil water separation, silt screens, etc.; and Regular and dedicated procedures for the management of stormwater collection, settling, testing and eventual discharge of 'clean' water to marine water. This should also include associated measures required to prevent high sediment concentration stormwater drainage to marine water. <p><u>Hydrology:</u></p> <ul style="list-style-type: none"> Runoff within, upstream of, and adjacent to the worksite will be effectively drained away without causing flooding in the vicinity; Potential increase of peak-flow due to the change in the land use at the worksite can be 							

Environmental Parameter	Environmental Issue	Minimum Control Measures	Mitigation Measures	Monitoring Parameter	Monitoring Locations	Recommended Frequency of Monitoring	Monthly Reporting	Site Responsibility	Triggers ^{4,5}
		<p>mitigated by providing detention tanks/ponds within the Study Area. Detention tanks/ponds can capture stormwater during heavy storm events to reduce the peak runoff.</p> <ul style="list-style-type: none"> • Geotechnical aspect of site's slope stability (such as Earth Retaining and Stabilising structures (ERSS) to be included in detailed design engineering for the construction stage; and • The design engineers for detailed design may need to ensure that Earth Retaining Stabilisation structures (ERSS) are proposed when the site is cleared and excavated. Concurrently the ECO must ensure that these measures are implemented in the construction phase, as cutting of slopes may result in slope instability. 							
	<ul style="list-style-type: none"> • Improper Management of Chemical Substances 	<ul style="list-style-type: none"> • Development of SOP for safe handling, transfer and storage of toxic waste; housekeeping checks once a day to ensure all toxic waste is cleared from site; • Appropriate tests to ascertain the presence/absence of contamination of the excavated earth and sand; • Appropriate fully sheltered storage area with storage volume to be 110% of the largest volume of chemical substances to be stored (kerb up and enclosed on at least 3 sides, covered and with adequate ventilation); • Appropriate construction material for toxic waste storage containers with leak detection tests conducted periodically; • Provision of secondary containment for all toxic waste stored in bulk as per the requirements in the COPPC/SS593; • Preparation of an emergency response plan, training of the emergency response team (ERT) to be competent in the response mechanism and provision of response kits for any spillages; • Consignment notification/tracking system and transport emergency response plan for transport of toxic waste; • Appropriate disposal of toxic waste as per required in the Environmental Public Health (Toxic Industrial Waste) Regulations by licensed waste operator/collector. • Vessels to be equipped with spill kits and crew to receive proper training on their use; and • Contractor to establish an Emergency Response Plan (ERP) to manage a collision situation, and establish the necessary protocols and procedures. 	N.A.						
Underwater Noise	Noise from construction machines and equipment, includes marine vessels.	Currently, there are no standard practices mandated for underwater noise.	Switch off boat engine when onloading/ offloading fill material.	N.A.	N.A.	N.A.	N.A.	N.A.	N.A.

8.11.2 Operational Phase

The EMMP for operational phase of the project is described in Table 8-6 below.

Table 8-6 Proposed environmental monitoring and management plan for the operational phase.

Environmental Parameter	Environmental Issue	Minimum Control Measures	Mitigation Measures	Monitoring Parameter	Monitoring Locations	Recommended Frequency of Monitoring	Site Responsibility	Triggers ^{6,7}
Biodiversity	Minimisation of operational impacts to flora/vegetation	-	<ul style="list-style-type: none"> Identify of areas that are responding poorly due to operational activities Ensure that post-construction planting is responding well to development surrounding 	Flora and Arboriculture	Softscape of operational boundary	Monthly for duration of 1 year	CT, EHS, Floral Specialist, Arborist	N.A.
		-	<ul style="list-style-type: none"> Ensure integrity of adjacent forest (if any) Identify signs of edge effects on new forest edge of adjacent forest (if any) 		Adjacent forest to development boundary			
	Minimisation of operational impacts to fauna	<ul style="list-style-type: none"> Ensure water quality minimum control measures listed below are adhered to. 	<ul style="list-style-type: none"> Assessment of habitat quality (e.g., water quality, excessive vegetation removal) Inspection for presence of trapped/injured/dead fauna, potential fauna entrapments and gaps in site hoarding Recording of number of number of occurrences of human-wildlife conflict Conduct biodiversity survey to monitor construction impacts on fauna activity and presence 	Fauna	Adjacent forest to development boundary		CT, EHS, Ecologist	
Marine Water (including hydrology, hydrodynamics, water quality and morphology)	<ul style="list-style-type: none"> Permanent land use change Improper management of liquid and solid wastes 	<ul style="list-style-type: none"> To prepare sufficient disposal bins surrounding of the Project to avoid improper disposal of waste; To conduct regular inspection on wastes' storage system of the Project; To monitor the proposed waterbodies and its surroundings with CCTV surveillance regularly to ensure no contamination occurred; To develop an emergency response plan and conduct adequate training to maintenance workers to cope the accidental water contamination; and Raising awareness of various stakeholders with community/stakeholder engagement (e.g. signage boards, warning signs, etc.) 	N.A.	All parameters identified in Table 8-4.	Identified marine water quality monitoring locations (refer to Figure 8-8).	Monthly inspection for the marine water quality during first three (3) month of operational period.	EHS Officer	Investigation and corrective actions to be taken, when: <ul style="list-style-type: none"> The following documentation are found inadequate/missing: <ul style="list-style-type: none"> ECM Plan; Monitoring Log; Training Log; Audit Reports; If the monitored parameters exceed applicable values of either NEA's Allowable Limits for Trade Effluent Discharge into Watercourse or ASEAN Marine Water Quality Criteria as listed in Table 7-4; If the monitored parameters exceed applicable values of criteria as mentioned above or existing baseline conditions in Table 7-4 or Table 7-16 (whichever is higher) at identified sensitive receptors; If complaints are received due to project activities; and If visual non-compliance to any of the minimum control or mitigation measures are observed on-site.

⁶ Resident Technical Officer (RTO) and Site Officers (SO, WSHO and ECO) check the Study Area for construction progress and implementation of environmental mitigation measures.

⁷ If there is trigger then all the mitigation and management measures should be audited in detail for compliance and corrective action must be taken in liaison with the Project Owner.

9 Stakeholder Engagement

Multiple stakeholder engagements and consultations with experts and Agencies were conducted throughout the duration of this Project.

Dr. Daniel Friess, who is both a member of R.U.M. and the principal investigator of the completed feasibility study, was appointed as the technical advisor for the design and planning phase of this Project. Through numerous rounds of technical consultations, Dr. Friess reviewed the proposed preliminary conceptual design and provided some suggestions for AECOM design team's consideration.

A presentation was conducted on 19 August 2022 to provide an overview of the conceptual design to the FUN work group on the Project. The slides included details of the proposed scope of works and design layout. Next, a second stakeholder engagement session was carried out on 29 November 2022 to present the updates to the conceptual design, environmental impact assessment findings and to seek their feedback and suggestions. During this session, the FUN work group members queried on the social impacts to the Kampong Durian villagers living near the Site. AECOM noted that the impacts to the local residents were also considered during both the design and EIA stages. The recommended mitigation measures for fauna protection, such as avoidance of night-time works and recommendation of restricting working hours to 0800–1800, can also similarly minimise potential impacts to the quality of life of the villagers. Furthermore, a well-developed noise management plan should be implemented during the construction phase to minimise any noise pollution from the worksites. In addition, the worksite would also be hoarded up to ensure the safety of the villagers and the public. NParks would also engage the villagers before and during the construction to address any concerns, inconveniences or disturbances faced due to the proposed works.

Apart from FUN, AECOM has consulted other stakeholders including Ministry of National Development (MND), Maritime and Port Authority (MPA), Singapore Food Agency (SFA), the National Environment Agency (NEA), and Urban Redevelopment Authority (URA) during the inception stage and has enhanced the impact study scope based on their feedback. The impact study findings were also submitted for review and comment by the Agencies.

Based on the stakeholders', Agencies' and expert groups' comments on the environmental impact assessment study, the report was further revised and prepared for final public disclosure.

10 Conclusion

This section will present the summary of conclusions and recommendations from the assessed potential environmental impacts. The unmitigated impact significance and potential residual impact significance of the assessed environmental aspects are summarised in Table 10-1 below.

Table 10-1 Summary of impact significance for construction and operational phases

Environmental Parameter	Sensitive Receptor	Impact Significance with Minimum Control	Key Mitigation Measures (if any)	Impact Significance After Implementation of Mitigation Measures (if required)
Construction phase				
Biodiversity	Habitats	<ul style="list-style-type: none"> Mostly Negligible Only Major and Moderate to soft-sediment seabed due to habitat loss and habitat degradation 	<ul style="list-style-type: none"> Conduct regular inspections to ensure contractor compliance to the EMMP, with oversight by NParks. Engage flora specialists to assess if affected species can be harvest/transplanted before the start of works, including the seagrass species within the worksite that will be impacted. Soil to be filled manually/low impact machinery. This will help reduce fauna mortality and sedimentation. Limited access point for backfilling to an area where least vegetation will be affected. Stagger backfilling of the Ponds to allow fauna usage. Night works should be avoided to prevent disturbance to nocturnal fauna; recommended to restrict working hours to 0800-1800. Establish a Wildlife Response Plan in consultation with NParks Animal Management Centre and NParks Ubin Management, to be executed during 	<ul style="list-style-type: none"> Mostly Negligible Moderate impact due to habitat degradation drop to Minor However, Major due to habitat loss remains
	Flora	<ul style="list-style-type: none"> Largely Minor to Negligible Only Moderate to 5 species: <ul style="list-style-type: none"> <i>Halophila ovalis</i> due to mortality <i>Ceriops tagal</i>, <i>Ceriops zippeliana</i>, <i>Lumnitzera littorea</i>, <i>Lumnitzera racemosa</i> due to decline in plant health 		<ul style="list-style-type: none"> Largely Minor to Negligible <i>Halophila ovalis</i> remains as Moderate <i>Ceriops tagal</i>, <i>Ceriops zippeliana</i>, <i>Lumnitzera littorea</i>, <i>Lumnitzera racemosa</i> drop to Minor
	Fauna	<ul style="list-style-type: none"> Moderate to marine species residing within Ponds and mud mound lobster due to accidental injury or mortality Moderate to terrestrial species and mud mound lobster due to human-wildlife conflict and human disturbances 		<ul style="list-style-type: none"> Largely decreased to Minor Moderate for horseshoe crab due to mortality remains

Environmental Parameter	Sensitive Receptor	Impact Significance with Minimum Control	Key Mitigation Measures (if any)	Impact Significance After Implementation of Mitigation Measures (if required)
			<p>encounters with trapped, injured or dead wildlife, as well as incidents of human-wildlife conflict.</p> <ul style="list-style-type: none"> • Train site personnel on biodiversity awareness and actions to take when encountering wildlife. • Ensure good housekeeping controls such as provision of wildlife-proof bins and eating areas to prevent macaques from accessing anthropogenic food sources. 	
Marine Water Quality (excluding sediment plume)	On-site construction workers	Negligible Negative	N.A.	N.A.
	Off-site residents and visitors (recreational facilities including Serangoon Harbour, jetties, Jelutong Campsite, etc.)	Negligible Negative	N.A.	N.A.
	Habitats and biocenosis in the vicinity of Project Site	Negligible Negative	N.A.	N.A.
	International Boundary (IB)	Negligible Negative*	N.A.	N.A.
Sediment Plume	Off-site residents and visitors (recreational facilities including Serangoon Harbour, jetties, Jelutong Campsite, etc.)	Minor Negative	N.A.	N.A.

Environmental Parameter	Sensitive Receptor	Impact Significance with Minimum Control	Key Mitigation Measures (if any)	Impact Significance After Implementation of Mitigation Measures (if required)
	Seagrass (including Chek Jawa)	Minor Negative	N.A.	N.A.
	Mangrove along the southern shoreline of Pulau Ubin	Minor to Major Negative	<ul style="list-style-type: none"> To use Cage Type Grab Dredger To install double layers of silt curtains surrounding the working areas when pond filling activities are carried out 	Negligible to Minor Negative
	Aquaculture farms	Negligible Negative	N.A.	N.A.
	International Boundary (IB)	Negligible Negative*	N.A.	N.A.
Underwater Noise	Habitats and biocenosis in the vicinity of Project Site	Minor Negative	<ul style="list-style-type: none"> Switch off boat engine when onloading/offloading fill material. 	Negligible Negative
	Aquaculture farms	Minor Negative		Negligible Negative
Operational Phase				
Biodiversity	Habitats	Negligible to Minor	<ul style="list-style-type: none"> Put up informative signboards at high traffic area such as the pavilion to educate the public on healthy interactions with wildlife, such as macaques and snakes which may be perceived as threats. No feeding and no handling signboards should also be erected around the mangrove 	Minor Negative to Positive
	Fauna	<ul style="list-style-type: none"> Largely Negligible Only Moderate to Macaques due to human-wildlife conflict 		Negligible Negative to Minor Negative
Marine Water Quality	Off-site residents and visitors	Negligible Negative to Positive	N.A.	N.A.
	Habitats and biocenosis in the vicinity of Project Site	Negligible Negative to Positive	N.A.	N.A.
	International Boundary (IB)	Negligible Negative* to Positive	N.A.	N.A.

Environmental Parameter	Sensitive Receptor	Impact Significance with Minimum Control	Key Mitigation Measures (if any)	Impact Significance After Implementation of Mitigation Measures (if required)
Hydrodynamic	Navigation channel near the southern coast of Pulau Ubin (i.e. Serangoon Harbour)	Negligible Negative	N.A.	N.A.
	International Boundary (IB)	Negligible Negative*	N.A.	N.A.
Morphology	Habitats and biocenosis in the vicinity of Project Site	Negligible Negative to Positive	N.A.	N.A.
	International Boundary (IB)	Negligible Negative*	N.A.	N.A.
<p>Note:</p> <ol style="list-style-type: none"> * – As per Table 5-6 and Table 5-7, 'Negligible Negative' is equivalent to 'No expected changes / No contamination or likely to be well within regulatory limits / No detectable change'. Hence, there are no transboundary impacts. N.A. – as the negative impact significance is below moderate, no mitigation measures are required and no residual impact was assessed. 				

11 References

11.1 Legislations, Standards and Guidelines

- R-1. National Parks Board (NParks). Conserving Our Biodiversity – Singapore's National Biodiversity Strategy and Action Plan (NBSAP). 2019.
https://www.nparks.gov.sg/-/media/nparks-real-content/biodiversity/national-plan/singapore_2009-nbsap_updated-may-2019_national-targets.pdf
- R-2. Legislation Division of Attorney General's Chambers of Singapore. Wild Animals and Birds Act. 2000.
<https://sso.agc.gov.sg/Act/WABA1965>
- R-3. Legislation Division of Attorney General's Chambers of Singapore. Parks and Trees Act. 2006.
<https://sso.agc.gov.sg/Act/PTA2005>
- R-4. Legislation Division of Attorney General's Chambers of Singapore. Parks and Trees Regulations. 2006.
<https://sso.agc.gov.sg/SL/PTA2005-RG1>
- R-5. Legislation Division of Attorney General's Chambers of Singapore. Parks and Trees (Heritage Road and Green Buffers) Order. 2006.
<https://sso.agc.gov.sg/SL/PTA2005-OR2?DocDate=20061130&ValidDate=20061130>
- R-6. Legislation Division of Attorney General's Chambers of Singapore. Parks and Trees (Preservation of Trees) Order. 1998.
<https://sso.agc.gov.sg/SL/PTA2005-OR1?DocDate=20171117>
- R-7. IUCN I (2012) Red List of Threatened Species: Version 2011.2.
- R-8. Hong Kong Environmental Protection Department. Environmental Impact Assessment Ordinance - Technical Memorandum. 2011.
<https://www.epd.gov.hk/eia/english/legis/index3.html>
- R-9. National Parks Board, 2020. Biodiversity Impact Assessment (BIA) Guidelines.
<https://www.nparks.gov.sg/-/media/nparks-real-content/biodiversity/bia-guidelines.pdf?la=en&hash=67BBB6F740AE7CCE941D82B261BB3DAF9CF537B1>
- R-10. Legislation Division of Attorney General's Chambers of Singapore. Environmental Protection and Management Act. 2020
<https://sso.agc.gov.sg/Act/EPMA1999>
- R-11. Legislation Division of Attorney General's Chambers of Singapore. Environmental Protection and Management (Trade Effluent) Regulations. 2008.
<https://sso.agc.gov.sg/SL/EPMA1999-RG5>
- R-12. Singapore Standards SS593:2013. Code of Practice for Pollution Control (COPPC). 2013.
- R-13. Legislation Division of Attorney General's Chambers of Singapore. Sewerage and Drainage Act (Chapter 294). 2001.
<https://sso.agc.gov.sg/Act/SDA1999>
- R-14. Legislation Division of Attorney General's Chambers of Singapore. Sewerage and Drainage (Trade Effluent) Regulations. 2007.
<https://sso.agc.gov.sg/SL/SDA1999-RG5?DocDate=20161003>
- R-15. Legislation Division of Attorney General's Chambers of Singapore. Sewerage and Drainage (Surface Water Drainage) Regulations. 2007.
<https://sso.agc.gov.sg/SL/SDA1999-RG4?DocDate=20070515>

- R-16. Public Utilities Board (PUB), 2018, Code of Practice on Surface Water Drainage.
https://www.pub.gov.sg/Documents/COP_Final.pdf
- R-17. Public Utilities Board, Singapore (PUB), 2015, Preventing Muddy Waters from the Construction Sites.
<https://www.pub.gov.sg/Documents/Circular2015Oct28.pdf>
- R-18. United States Environmental Protection Agency, United States (USEPA), 2017, Water Quality Standards Handbook.
<https://www.epa.gov/wqs-tech/water-quality-standards-handbook>
- R-19. National Environment Agency of Singapore (NEA), 2021, Singapore's Water Quality Guidelines for Recreational Beaches.
<https://www.nea.gov.sg/our-services/pollution-control/water-quality/recreational-beaches>
- R-20. National Environment Agency, Singapore (NEA). Allowable Limits for Trade Effluent Discharge to Watercourse or Controlled Watercourse.
<https://www.nea.gov.sg/our-services/pollution-control/water-quality/allowable-limits-for-trade-effluent-discharge-to-watercourse-or-controlled-watercourse>
- R-21. Legislation Division of Attorney General's Chambers of Singapore, 2018, Environmental Protection and Management (Chapter 94A).
<https://sso.agc.gov.sg/Act/EPMA1999#xv->
- R-22. Association of Southeast Asian Nations (ASEAN). ASEAN Marine Water Quality Management Guidelines and Monitoring Manual. 2008
<https://environment.asean.org/wp-content/uploads/2015/07/ASEAN-MarineWaterQualityManagementGuidelinesandMonitoringManual.pdf>
- R-23. Maritime and Port Authority of Singapore (MPA), 2020, Port Marine Circular No. 033 of 2020, Annex A.
<https://www.mpa.gov.sg/web/wcm/connect/www/7d113fd3-fc0f-40c2-87dc-7e58d3c3972a/pc20-033.pdf?MOD=AJPERES>
- R-24. Legislation Division of Attorney General's Chambers of Singapore, 2017, Prevention of Pollution of the Sea Act (Chapter 243).
<https://sso.agc.gov.sg/Act/PPSA1990?ProvIds=xv-#xv->
- R-25. Legislation Division of Attorney General's Chambers of Singapore, 2002, Fisheries Act (Chapter 111).
<https://sso.agc.gov.sg/Act/FA1966>
- R-26. United Nations, Conservation on Migratory Species of Wild Animals (CMS), 2017, Technical Support Information to the CMS Family Guidelines on Environmental Impact Assessments for Marine Noise-generating Activities.
https://www.cms.int/sites/default/files/basic_page_documents/CMS-Guidelines-EIA-Marine-Noise_TechnicalSupportInformation_FINAL20170918.pdf
- R-27. United States Department of Commerce, National Marine Fisheries Service, 2018, Technical Guidance for Assessing the Effects of Anthropogenic Sound on Marine Mammal Hearing: Underwater Thresholds for Onset of Permanent and Temporary Threshold Shifts.
<https://tethys.pnnl.gov/sites/default/files/publications/NMFS2018.pdf>
- R-28. European Commission, 2010, Marine Strategy Framework Directive.
<https://publications.jrc.ec.europa.eu/repository/handle/JRC58105>
- R-29. Ecological Impact Assessment (EiA). EIANZ Guidelines for use in New Zealand: terrestrial and freshwater ecosystems. 2nd Edition. May 2018.
<https://www.eianz.org/document/item/4447>
- R-30. CIEEM (2018) Guidelines for Ecological Impact Assessment in the UK and Ireland: Terrestrial, Freshwater, Coastal and Marine. Chartered Institute of Ecology and Environmental Management, Winchester.

- R-31. Popper, et al. 2014. Sound Exposure Guidelines for Fishes and Sea Turtles: A Technical Report prepared by ANSI-Accredited Standards Committee S3/SC1 and registered with ANSI. SpringerBriefs in Oceanography, ASA Press, ISSN 2196-1220, ISBN 978-3-319-06658-5 Springer Cham Heidelberg New York Dordrecht London
- R-32. Singapore Statutes Online - Wildlife Act 1965, Section 10. <https://sso.agc.gov.sg/Act/WA1965#top>
- R-33. National Parks Board (2018) Guidelines on Greenery Provision and Tree Conservation for Developments.
- R-34. Crosher I, Gold S, Heaver M, Heydon M, Moore L, Panks S, Scott S, Stone D & White N (2019) The Biodiversity Metric 2.0: auditing and accounting for biodiversity value. User guide (Beta version, July 2019). Natural England.
- R-35. Hong Kong Environmental Protection Department. Environmental Impact Assessment Ordinance - Technical Memorandum. 2011.

11.2 Websites

- W-1. Conceicao JL (2009) Singapore Golf Club. Singapore infopedia.
https://eresources.nlb.gov.sg/infopedia/articles/SIP_1519_2009-05-11.html
- W-2. iNaturalist (2021). iNaturalist.
<https://www.inaturalist.org/>
- W-3. Gill F & Donsker D (2021) IOC World Bird List (v 10.1).
<https://www.worldbirdnames.org/new/>
- W-4. Lee Kong Chian Natural History Museum (2021) Biodiversity of Singapore.
<https://singapore.biodiversity.online>
- W-5. National Parks Board (2021) Flora and Fauna Web.
<https://www.nparks.gov.sg/florafauweb/>
- W-6. National University of Singapore Lee Kong Chian Natural History Museum (2021) Singapore Biodiversity Records Archives.
<https://lkcnhm.nus.edu.sg/publications/nature-in-singapore/singapore-biodiversity-records-archives/>
- W-7. Royal Botanic Gardens, Kew (2021) Plants of the World Online.
www.plantsoftheworldonline.org
- W-8. Royal Botanic Gardens, Kew (2021) World Checklist of Selected Plant Families.
<http://wcsp.science.kew.org/>
- W-9. Singapore Birds (2021) Birds of Singapore.
<http://singaporebirds.blogspot.com>
- W-10. Singapore Bird Group (2021) Singapore Bird Group.
<https://singaporebirdgroup.wordpress.com>
- W-11. Singapore Birds Project (2021) Singapore Birds Project.
<https://singaporebirds.com/>
- W-12. Singapore Land Authority (2015) Height Datum & Height Determination using GNSS in Singapore.
https://fig.net/resources/proceedings/2015/2015_07_vrfp_comm5/5A_Khoo_Singapore_Height_Datum.pdf

- W-13. Tan B (2019) Singapore Turf Club. Singapore infopedia.
https://eresources.nlb.gov.sg/infopedia/articles/SIP_136_2004-12-30.html
- W-14. The Biodiversity of Singapore (2021) The Biodiversity of Singapore.
<https://singapore.biodiversity.online/>
- W-15. World Register of Marine Species (2021) An authoritative classification and catalogue of marine name.
<http://marinespecies.org/>
- W-16. National Heritage Board of Singapore (Roots)
<https://www.roots.gov.sg/resources-landing/online-exhibitions/pulau-ubin>
- W-17. Singapore Infopedia
https://eresources.nlb.gov.sg/infopedia/articles/SIP_219_2004-12-13.html
- W-18. National Parks Board and Friends of Ubin Network (FUN). (2018)
<https://www.nparks.gov.sg/-/media/ubin/ubin-tide/npb-eng-enewsletterissue2.pdf>
- W-19. National Parks Board. Centre for Urban Greenery & Ecology. (2015). Sustainable Landscape
<https://www.nparks.gov.sg/-/media/cuge/ebook/sustainable-landscape/sustainable-landscape.pdf>
- W-20. Hsieh TC, Ma KH & Chao A (2020) Package 'iNEXT'.
<https://cran.r-project.org/web/packages/iNEXT/iNEXT.pdf>
- W-21. National Parks Board (2020) Flora and Fauna Web.
<https://www.nparks.gov.sg/florafaunaweb/>
- W-22. Tan, H (2011) Life History of the Common Jay.
<https://butterflycircle.blogspot.com/2011/06/life-history-of-common-jay.html?m=0>
- W-23. NParks (2019) Flora and Fauna Web. Typhlops muelleri.
<https://www.nparks.gov.sg/florafaunaweb/fauna/8/1/812>
- W-24. National Environment Agency (2021). Singapore's Water Quality guidelines for Recreational Beaches.
<https://www.nea.gov.sg/our-services/pollution-control/water-quality/recreational-beaches>
- W-25. L Mangrove Action Project (2022) "CBEMR" Mangrove Restoration.
<https://mangroveactionproject.org/mangrove-restoration/>
- W-26. National Environment Agency (2022). Beach Short-term Water Quality Information.
<https://www.nea.gov.sg/our-services/pollution-control/water-quality/recreational-beaches/beach-short-term-water-quality-information>
- W-27. Lepidoptera exotica: The Non-Natives Exotic butterfly species in Singapore.
<https://butterflycircle.blogspot.com/2020/03/lepidoptera-exotica.html>

11.3 Publications

- P-1. Ascher JS & Pickering J (2018) Discover Life bee species guide and world checklist (Hymenoptera: Apoidea: Anthophila).
- P-2. Baker N and Lim KKP (2012) Wild Animals of Singapore: A Photographic Guide to Mammals, Reptiles, Amphibians and Freshwater Fishes (2nd edition). Draco Pub and Distribution, Singapore.

- P-3. Brook BW, Sodhi NS & Ng PK (2003) Catastrophic extinctions follow deforestation in Singapore. *Nature*, 424(6947): 420-426.
- P-4. Cai Y, Ng PKL & Choy S (2007) Freshwater shrimps of the family Atyidae (Crustacea: Decapoda: Caridea) from Peninsular Malaysia and Singapore. *Raffles Bulletin of Zoology*, 55: 277–309.
- P-5. Chong KY, Tan HT, & Corlett RT (2009) A checklist of the total vascular plant flora of Singapore: native, naturalised and cultivated species. *Raffles Museum of Biodiversity Research*, Singapore.
- P-6. Chua MAH & Lim KKP (2011) Mammals: A – Z entries. In: Ng PKL, Corlett RT & Tan HTW (eds.) *Singapore Biodiversity: An Encyclopedia of the Natural Environment and Sustainable Development*. Editions Didier Millet (Singapore), pp. 552.
- P-7. Corlett RT (1992) The ecological transformation of Singapore. *Journal of Biogeography*, 19: 411–420. P-42.
- P-8. Davison GWH, Ng PKL & Ho HC (2008) *The Singapore Red Data Book: Threatened Plants and Animals of Singapore*. 2nd edition. Nature Society (Singapore), Singapore.
- P-9. Giam XL, Ng TH, Lok AFS & Ng HH (2011) Local geographic range predicts freshwater fish extinctions in Singapore. *Journal of Applied Ecology*, 48(2): 356-363.
- P-10. Ho JK, Ramchunder SJ, Memory A, Theng M, Li T, Clews E, Cai Y, Tan HH, & Yeo DC (2016) *A Guide to the Freshwater Fauna of Nee Soon Swamp Forest*. Lee Kong Chian Natural History Museum & Tropical Marine Science Institute, National University of Singapore.
- P-11. Jain A, Khew SK, Cheong WG & Webb EL (2018) Butterfly extirpations, discoveries and rediscoveries in Singapore over 28 years. *Raffles Bulletin of Zoology*, 66: 217–257.
- P-12. Khew SK (2015) *A Field Guide to the Butterflies of Singapore* (2nd edition). Ink Communications Pte Ltd, Singapore.
- P-13. Kottelat M (2013) The fishes of the inland waters of Southeast Asia. A catalogue and core bibliography of the fishes known to occur in freshwaters, mangroves and estuaries. *Raffles Bulletin of Zoology*, Supplement 27: 1–663.
- P-14. Lane DJW, Kingston T & Lee BPYH (2006) Dramatic decline in bat species richness in Singapore, with implications for Southeast Asia. *Biological Conservation*, 131: 584–593.
- P-15. National Heritage Board (2018) *Bukit Timah Heritage Trail: A Companion Guide*. National Heritage Board.
- P-16. Ngiam RWJ & Cheong LF (2016) The dragonflies of Singapore: an updated checklist and revision of the national conservation statuses. *Nature in Singapore*, 9: 149–163.
- P-17. Ng PKL (1997) The conservation status of freshwater prawns and crabs in Singapore with emphasis on the nature reserves. *Gardens' Bulletin Singapore*, 49: 267–272.
- P-18. Ng PKL & Lim KKP (1997) The diversity and conservation status of fishes in the nature reserves of Singapore. *Gardens' Bulletin Singapore*, 49(2): 245–265.
- P-19. Ng PKL, Corlett R and Hugh TW Tan (2011). *Singapore Biodiversity: An Encyclopedia of the Natural Environment and Sustainable Development*. Raffles Museum of Biodiversity Research, National University of Singapore.
- P-20. Nor ANM, Corstanje R, Harris JA, Grafius DR & Siriwardena GM (2017) Ecological connectivity networks in rapidly expanding cities. *Heliyon*, 3(6), e00325.

- P-21. Pyšek, P, DM Richardson, M Rejmánek, GL Webster, M Williamson & J Kirschner (2004) Alien plants in checklists and floras: towards better communication between taxonomists and ecologists. *Taxon*, 53 (1): 131–143.
- P-22. Soh ZWW & Ascher JS (2020) A Guide to the Bees of Singapore. National Parks Board, Singapore.
- P-23. Soh ZWW & Ngiam RWJ (2013) Flower-visiting bees and wasps in Singapore Parks (Insecta: Hymenoptera). *Nat. Singapore* 6: 153–172.
- P-24. Soh M, Ng M & Ngiam RWJ (2019) New Singapore record of a dragonfly, *Indothemis carnatica* with an updated Singapore Odonata checklist. *Singapore Biodiversity Records*, 2019: 10–17.
- P-25. Suzuki T, Shibukawa K, Senou H, Chen I-S (2015) [issued 2016] Redescription of *Rhinogobius similis* Gill 1859 (Gobiidae: Gobionellinae), the type species of the genus *Rhinogobius* Gill 1859, with designation of the neotype. *Ichthyological Research*, 63: 227–238.
- P-26. Tan HH, Lim KKP, Liew JH, Low BW, Lim RBH, Kwik JTB & Yeo DCJ (2020) The non-native freshwater fishes of Singapore: an annotated compilation. *Raffles Bulletin of Zoology*, 68: 150–195.
- P-27. Tang HB, Wang LK & Hämäläinen M (2010) A Photographic Guide to the Dragonflies of Singapore. Raffles Museum of Biodiversity Research, National University of Singapore.
- P-28. Teo RCH & Rajathurai S (1997) Mammals, reptiles and amphibians in the nature reserves of Singapore – diversity, abundance and distribution. *The Gardens' Bulletin Singapore*, 49(4): 353–425.
- P-29. Theng M, Jusoh WFA, Jain A, Huertas B, Tan DJX, Tan HZ, Kristensen NP, Meier R & Chisholm RA (2020) A comprehensive assessment of diversity loss in a well-documented tropical insect fauna: almost half of Singapore's butterfly species extirpated in 160 years. *Biological Conservation*, 242(108401).
- P-30. Wowor D & Ng PKL (2010) On two new genera of Asian prawns previously assigned to *Macrobrachium* (Crustacea: Decapoda: Caridea: Palaemonidae). *Zootaxa*, 2372, 37–52.
- P-31. Gaw LY, Yee AT, Richards DR (2019) A High-Resolution Map of Singapore's Terrestrial Ecosystems. *Data* 4(3): 116–127
- P-32. Yee AT, Chong KY, Neo L & Tan HT (2016) Updating the classification system for the secondary forests of Singapore. *Raffles Bulletin of Zoology*.
- P-33. Yee ATK, Chong KY, Seah WW, Lua HK & Yang S (2019) Vegetation of Singapore. *Flora of Singapore* (1): 47-70.
- P-34. Yeo DCJ (2010) Introduced decapod crustaceans in Singapore's reservoirs. *Cosmos* 6(1):85–90.
- P-35. Friess, D & Leng, G (2017) Ecological Mangrove Restoration on Pulau Ubin: Site suitability surveys.
- P-36. Collen AL (2012) The evolution of echolocation in bats: a comparative approach. Doctoral thesis, University College London.
- P-37. Hughes A, Satasook C, Bates PJJ, Soisook P, Sritongchuay T, Jones G & Bumrungsri (2011) Using echolocation calls to identify Thai bat species: Vespertilionidae, Emballonuridae, Nycteridae and Megadermatidae. *Acta Chiropterologica*, 13(2): 447–455.
- P-38. Pottie SA, Lane DJW, Kingston T & Lee BPY-H (2005) The microchiropteran bat fauna of Singapore. *Acta Chiropterologica*, 7(2): 237–247.
- P-39. Chao A & Jost L (2012) Coverage-based rarefaction and extrapolation: standardizing samples by completeness rather than size. *Ecology*, 93(12): 2533–2547.
- P-40. Dyer KR, Christie MC and Wright EW (2000) The classification of intertidal mudflats. *Continental Shelf Research*, 20(10): 1039–1060.

- P-41. Waycott M, Duarte CM, Carruthers TJB, Orth RJ, Dennison WC, Olyarnik S, Calladine A, Fourqurean JW, Heck KL Jr, Hughes AR, Kendrick GA, Kenworthy WJ, Short FT, and Williams SL (2008) Accelerating loss of seagrasses across the globe threatens coastal ecosystems. *Proceeding of National Academy of science of United States of America*, 106(30): 12377–81.
- P-42. Orth RJ, Carruthers TJB, Dennison WC, Duarte CM, Fourqurean JW, Heck KL, Hughes AR, Kendrick GA, Kenworthy WJ, Olyarnik S, Waycott, M Short FT, and Williams SL (2006) A global crisis for seagrass ecosystems. *Bioscience* 56: 987–996.
- P-43. Paton PW (1994) The effect of edge of avian nest success: how strong is the evidence? *Conservation biology*, 8(10), 17–26.
- P-44. Murcia C (1995) Edge effects in fragmented forests: implications for conservation. *Trends in Ecology & Evolution*, 10(2): 58–62.
- P-45. Didham RK (1997) An overview of invertebrate responses to forest fragmentation. *Forests and insects*, 303–320.
- P-46. Laurance WF & Bierregaard RO (1997) *Tropical forest remnants: ecology, management, and conservation of fragmented communities*. University of Chicago Press, Chicago.
- P-47. Tan DJX, Yong DL, Low BW, Owyong A & Chia A (2017) Anthropogenic sources of non-migratory avian mortalities in Singapore. *The International Journal of Tropical Veterinary and Biomedical Research*, 2(2): 17–27.
- P-48. Lok AFSL, Ang WF, Ng BYQ, Leong TM, Yeo CK & Tan HT (2013) Native fig species as a keystone resource for the Singapore urban environment. Singapore: Raffles Museum of Biodiversity Research, National University of Singapore.
- P-49. Gan CW & Tea YK (2018) The dwarf crow butterfly, *Euploea tulliolus*, in Singapore. *Singapore Biodiversity Records 2018*: 139–141.
- P-50. Baker N and BC Ng (2014) White-bellied blind snake at Ulu Sembawang. *Singapore Biodiversity Records 2014*: 257.
- P-51. Said F, Yu K, Tan R, Henricksen M & Chua MAH (2022) Biodiversity Record: Recent sightings of mainland leopard cats on Pulau Ubin. *Nature in Singapore*, 15: e2022013. DOI: 10.26107/NIS-2022-0013
- P-52. Chua MAH, Sivasothi N & Teo R (2009) Rediscovery of greater mouse deer, *Tragulid napu* (Mammalia: Artiodactyla: Tragulidae) in Pulau Ubin, Singapore. *Nature in Singapore*. 2: 373–378.
- P-53. Chua, MAH (2015) Greater mousedeer in Western Catchment Area. *Singapore Biodiversity Records*. 2015: 8.
- P-54. Lewis III, R. R. (2001) Mangrove Restoration - Costs and Benefits of Successful Ecological Restoration. In: *Mangrove Valuation Workshop*.
- P-55. Laulikitnont, P. (2022). *Evaluation of Mangrove Ecosystem Restoration Success in Southeast Asia*. University of San Francisco.
- P-56. Brown, B., Fadillah, R., Nurdin, Y., Soulsby, I., & Ahmad Gaëll Mainguy, R. (2022). CASE STUDY: Community Based Ecological Mangrove Rehabilitation (CBEMR) in Indonesia. *Sapiens*, 7(2). Retrieved 1 July 2022, from <https://journals.openedition.org/sapiens/1589>.
- P-57. Friess, DA (2017) Mangrove rehabilitation along urban coastlines: A Singapore case study, *Regional Studies in Marine Science*, 16: 1279-289.
- P-58. Lee, SK, Tan, WH, Havanond, S (1996) Regeneration and colonisation of mangrove on clay-filled reclaimed land in Singapore. *Hydrobiologia*, 319: 23-25.

- P-59. Panapitukkul, N, Duarte, CM, Thampanya, U, Kheowvongsri, P, Srichai, N, Geertz-Hansen, O, Terrados, J, Boromthananarath, S (1998) Mangrove colonization: mangrove progression over the growing Pak Phanang (SE Thailand) mud flat. *Estuarine, Coastal and Shelf Science*, 47(1): 51-61.
- P-60. Thampanya, U, Vermaat, JE, Sinsakul, S, Panapitukkul, N (2006) Coastal erosion and mangrove progradation of Southern Thailand. *Estuarine, coastal and shelf science*, 68(1-2), pp.75-85.
- P-61. Mishra, AK, & Apte, D (2019) Ecological association between seagrass and mangrove ecosystems increases seagrass population longevity in island ecosystem. *bioRxiv*, p.707745.
- P-62. Carlson, RR, Evans, LJ, Foo, SA, Grady, BW, Li, J, Seeley, M, Xu, Y & Asner, GP (2021) Synergistic benefits of conserving land-sea ecosystems. *Global Ecology and Conservation*, 28: e01684.
- P-63. Hidayah, N, Ng, CT, Arina, N, Fairouz, M & Rozaimi, M (2022) Macroalgal and mangrove provenances demonstrate their relevance in contributing to the blue carbon pool of a tropical seagrass meadow. *Ecological Research*, 37(1), pp.21-32.
- P-64. Brown, B., Fadillah, R., Nurdin, Y., Soulsby, I & Ahmad, R (2014) CASE STUDY: Community Based Ecological Mangrove Rehabilitation (CBEMR) in Indonesia. From small (12-33 ha) to medium scales (400 ha) with pathways for adoption at larger scales (> 5000 ha). *SAPI EN. S. Surveys and Perspectives Integrating Environment and Society*(7.2).
- P-65. Lindsay et al. (2022) Flora of Singapore: Checklist and bibliography. *Gardens' Bulletin Singapore* 74(1), pp. 3-860.
- P-66. Schubart CD & Ng PKL (2020) Revision of the intertidal and semiterrestrial crab genera *Chiromantes* Gistel, 1848, and *Pseudosesarma* Serène & Soh, 1970 (Crustacea: Brachyura: Sesarmidae), using morphology and molecular phylogenetics, with the establishment of nine new genera and two new species. *Raffles Bulletin of Zoology*, 68: 891–994.
- P-67. Lee BY, Ng NK & Ng PKL (2015) The taxonomy of five species of *Episesarma* De Man, 1895, in Singapore (Crustacea: Decapoda: Brachyura: Sesarmidae). *Raffles Bulletin of Zoology*, 31: 199–215.
- P-68. Wu, G., Hong, H., & Yan, C. (2015). Arsenic Accumulation and Translocation in Mangrove (*Aegiceras corniculatum* L.) Grown in Arsenic Contaminated Soils. *International Journal Of Environmental Research And Public Health*, 12(7), 7244-7253. Retrieved 1 July 2022, from <https://doi.org/10.3390/ijerph120707244>.
- P-69. Teaioro I (1999). The Effects of Turbidity on Suspension Feeding Bivalves. *Environmental Science*.
- P-70. Karel E (1999). Ecological effects of dumping of dredged sediments; options for management. *Journal of Coastal Conservation*, 5, pp. 69-80.
- P-71. Lindsay S, Middleton DJ, Ho BC, Chong KY, Turner IM, Ali Ibrahim, Alonso-García M, Ang WF, Ashton PS, Athen P, Atkins S, Bazilah Ibrahim, Beentje HJ, Boo CM, Boyce PC, Bramley GLC, Buerki S, Callmander MW, Chantanaorrapint S, Cheek M, Chen C-W, Chen J, Chen LMJ, Chew PT, Chong R, Choo LM, Chung RCK, Coode MJE, Chua SC, Cicuzza D, de Kok RPJ, Davison GWH, de Wilde WJJO, Duistermaat H, Dubéarnès A, Duyfjes BEE, Ellis LT, Esser H-J, Gajurel PR, Gale SW, Ganesan SK, Gardner EM, Geiger DL, Harwood RK, Hassan Ibrahim, He S, Henderson A, Hovenkamp PH, Hughes M, Zaki Jamil, Jebb MHP, Johnson DM, Kartonegoro A, Kiew R, Knapp S, Koh SL, Kurzweil H, Lee S, Leong PKF, Leong-Škorničková J, Levin GA, Liew DCH, Lim RCJ, Lim WH, Loo AHB, Low YW, Lua HK, Lum S, Mabblerley DJ, Mahyuni R, Maslin B, Murray NA, Neo L, Ng XY, Ngo KM, Niissalo MA, Ong PT, Pannell CM, Phang A, Prance GT, Promma C, Puglisi C, Rodda ML, Rubasinghe SCK, Saunders RMK, Savinov IA, Saw LG, Schuiteman A, Seah WW, Simpson DA, Strijk JS, Sukkharak P, Sugumaran M, Syahida-Emiza S, Tan JPC, Taylor NP, Teo YKL, Thomas DC, Trias-Blasi A, Utteridge T, van Welzen PC, Veldkamp JF, Vermeulen J, Wang R, Wilkie P, Wei Y-M, Wong SY, Wong KM, Yaakub S, Yam TM, Yang S, Yao TL, Ye W, Yee ATK, Yeo CK, Yeoh YS, Yong C, Yong KT, Zerega NJC, Zhu R-L & Er KBH (2022) Flora of Singapore: Checklist and bibliography. *Gardens' Bulletin Singapore*, 74 (Supplement 1): 3–860.

- P-72. Ngiam R and Ng M (2022) A Photographic Field Guide to the Dragonflies & Damselflies of Singapore.
- P-73. Sofawi, A.B., Nazri, M.N., Rozainah, M.Z. (2017). Nutrient Variability in Mangrove Soil: Anthropogenic, Seasonal and Depth Variation Factors. *Applied Ecology and Environmental Research*: 15(4)
- P-74. Satyanarayana, B., Farid, I., Mohamad, K. A., Dahdouh-Duebas, F. (2010). Mangrove species distribution and abundance in relation to local environmental settings: A case-study at Tumpat, Kelantan Delta, east coast of peninsular Malaysia. *Botanica Marina*, 53(1): 79-88
- P-75. Cadiz PL, Calumpong HP and Chotikarn P. (2020) Carbon storage potential of natural and planted mangals in Trang, Thailand. *Applied ecology and environmental research*, 18(3): 4383-4403.
- P-76. Chuah, AL. (1998) Water Quality Study of the East Johor Strait. [Master's thesis, National University of Singapore].
- P-77. Gin, K. Y.-H., Lin, X., Sheng, Z. (2000). Dynamics and size structure of phytoplankton in the coastal waters of Singapore. *Journal of Plankton Research*, 22(8), 1465–1484. <https://doi.org/10.1093/plankt/22.8.1465>.
- P-78. Hildebrand, J. A. (2009). Anthropogenic and natural sources of ambient noise in the Ocean. *Marine Ecology Progress Series*, 395, 5–20. <https://doi.org/10.3354/meps08353>
- P-79. Erbe, C., Marley, S. A., Schoeman, R. P., Smith, J. N., Trigg, L. E., & Emling, C. B. (2019). The effects of ship noise on marine mammals—a review. *Frontiers in Marine Science*, 6. <https://doi.org/10.3389/fmars.2019.00606>
- P-80. Cruz, E. Lloyd, T., Bosschers, J., Lafeber, F.H., Vinagre, P. Vaz, G., (2021). Study on inventory of existing policy, research and impacts of continuous underwater noise in Europe. EMSA report EMSA/NEG/21/2020. WavEC Offshore Renewables and Maritime Research Institute Netherlands.
- P-81. Anderson, P. K., & Barclay, R. M. (1995). Acoustic signals of solitary dugongs: Physical characteristics and behavioral correlates. *Journal of Mammalogy*, 76(4), 1226–1237. <https://doi.org/10.2307/1382616>
- P-82. Southall, B.; Bowles, A.; Ellison, W.; Finneran, J.; Gentry, R.; Greene, C. Jr.; Kastak, D.; Ketten, D.; Miller, J.; Nachtigall, P.; Richardson, W.; Thomas, J.; Tyack, P. (2008). Marine Mammal Noise Exposure Criteria: Initial Scientific Recommendations. *Aquatic Mammals*, 33(4), 273-275. <https://doi.org/10.1080/09524622.2008.9753846>

11.4 Maps

- M-1. National Archives of Singapore (2021) Maps and Building Plans. https://www.nas.gov.sg/archivesonline/maps_building_plans/
- M-2. National University of Singapore Libraries (2021) Historical Maps of Singapore. <https://libmaps.nus.edu.sg/>
- M-3. OneMap (2021) Singapore Historical Map. <https://www.onemap.gov.sg/hm/>

11.5 Others

- O-1. Google Inc. (2013) Google Earth 7.1.2.2041. Google Inc., California.
- O-2. AECOM. Consultancy Services for Mangrove Restoration of Sungei Durian Ponds Environmental Impact Assessment (EIA) Inception Report – Rev 03, 02 March 2022.
- O-3. Quantum GIS Development Team (2017) Quantum GIS Geographic Information System. Open Source Geospatial Foundation Project. Version 2.18.14. <http://qgis.osgeo.org>.
- O-4. Wildlife Acoustics, Inc. (2021) Kaleidoscope Version Pro 5.4.6. <https://www.wildlifeacoustics.com>.

- O-5. R Development Core Team (2016) R Development Core Team R: A Language and Environment for Statistical Computing R Foundation for Statistical Computing, Vienna, Austria (<http://www.R-project.org>)

Appendix A
Flora Species List

Pulau Ubin Durian Appendix A - Flora Species List

Species	Family	Nativeness	National Conservation Status	Habit
<i>Acacia auriculiformis</i>	Fabaceae	Exotic	-	Tree
<i>Acrostichum aureum</i>	Pteridaceae	Native	Common	Shrub
<i>Adenanthera pavonina</i>	Fabaceae	Exotic	-	Tree
<i>Adiantum latifolium</i>	Adiantaceae	Exotic	-	Herb
<i>Allophylus cobbe</i>	Sapindaceae	Native	Common	Shrub
<i>Alstonia angustiloba</i>	Apocynaceae	Native	Common	Tree
<i>Alyxia reinwardtii</i>	Apocynaceae	Native	Common	Shrub
<i>Cyclosorus interruptus</i>	Thelypteridaceae	Native	Common	Herb
<i>Andrographis paniculata</i>	Acanthaceae	Exotic	-	Herb
<i>Antidesma velutinsum</i>	Phyllanthaceae	Native	Endangered	Tree
<i>Archidendron ellipticum</i>	Fabaceae	Native	Endangered	Tree
<i>Ardisia elliptica</i>	Primulaceae	Native	Endangered	Tree
<i>Areca catechu</i>	Arecaceae	Exotic	-	Tree
<i>Artabotrys suaveolens</i>	Annonaceae	Native	Common	Climber
<i>Artocarpus heterophyllus</i>	Moraceae	Exotic	-	Tree
<i>Artocarpus integer</i>	Moraceae	Cryptogenic	-	Tree
<i>Asplenium longissimum</i>	Aspleniaceae	Native	Common	Epiphyte
<i>Asplenium nidus</i>	Aspleniaceae	Native	Common	Epiphyte
<i>Averrhoa carambola</i>	Oxalidaceae	Exotic	-	Tree
<i>Avicennia alba</i>	Acanthaceae	Native	Common	Tree
<i>Avicennia officinalis</i>	Acanthaceae	Native	Common	Tree
<i>Avicennia rumphiana</i>	Acanthaceae	Native	Common	Tree
<i>Axonopus compressus</i>	Poaceae	Exotic	-	Herb
<i>Baccaurea motleyana*</i>	Phyllanthaceae	Native	Critically Endangered	Tree
<i>Bambusa heterostachya</i>	Poaceae	Exotic	-	Shrub
<i>Barringtonia racemosa</i>	Lecythidaceae	Native	Critically Endangered	Tree
<i>Bridelia stipularis</i>	Phyllanthaceae	Native	Vulnerable	Shrub
<i>Bruguiera cylindrica</i>	Rhizophoraceae	Native	Common	Tree
<i>Bruguiera gymnorhiza</i>	Rhizophoraceae	Native	Common	Tree
<i>Buchanania arborescens</i>	Anacardiaceae	Native	Common	Tree
<i>Caesalpinia crista</i>	Fabaceae	Native	Common	Climber
<i>Calamus cf. erinaceus</i>	Arecaceae	Native	Vulnerable	Climber
<i>Calophyllum inophyllum</i>	Calophyllaceae	Native	Endangered	Tree
<i>Canavalia rosea</i>	Fabaceae	Native	Common	Climber
<i>Cansjera rheedii</i>	Opiliaceae	Native	Vulnerable	Climber
<i>Caryota mitis</i>	Arecaceae	Native	Common	Tree
<i>Casuarina equisetifolia</i>	Casuarinaceae	Native	Common	Tree
<i>Centotheca lappacea</i>	Poaceae	Native	Common	Herb
<i>Ceriops tagal</i>	Rhizophoraceae	Native	Vulnerable	Tree
<i>Ceriops zippeliana</i>	Rhizophoraceae	Native	Endangered	Tree
<i>Euphorbia hirta</i>	Euphorbiaceae	Exotic	-	Herb
<i>Champereia manillana</i>	Opiliaceae	Native	Common	Tree
<i>Chassalia curviflora</i>	Rubiaceae	Native	Vulnerable	Tree
<i>Christella dentata</i>	Thelypteridaceae	Cryptogenic	-	Herb
<i>Cinnamomum iners</i>	Lauraceae	Native	Common	Tree
<i>Claoxylon indicum</i>	Euphorbiaceae	Native	Common	Tree
<i>Clausena excavata</i>	Rutaceae	Native	Common	Tree
<i>Miconia crenata</i>	Melastomataceae	Exotic	-	Shrub
<i>Cocos nucifera</i>	Arecaceae	Exotic	-	Tree
<i>Colubrina asiatica</i>	Rhamnaceae	Native	Common	Shrub
<i>Combretum indicum</i>	Combretaceae	Exotic	-	Climber
<i>Commersonia bartramia</i>	Malvaceae	Native	Common	Tree
<i>Cordyline fruticosa</i>	Asparagaceae	Exotic	-	Shrub
<i>Curculigo latifolia</i>	Hypoxidaceae	Native	Vulnerable	Herb
<i>Cynometra ramiflora</i>	Fabaceae	Native	Critically Endangered	Tree
<i>Cyperus iria</i>	Cyperaceae	Native	Common	Herb
<i>Cyperus javanicus</i>	Cyperaceae	Native	Common	Herb
<i>Cyperus mindorensis</i>	Cyperaceae	Native	Common	Herb
<i>Cyperus sphacelatus</i>	Cyperaceae	Exotic	-	Herb
<i>Cyperus trialatus</i>	Cyperaceae	Native	Common	Herb
<i>Cyrtococcum patens</i>	Poaceae	Native	Vulnerable	Herb
<i>Cyrtophyllum fragrans</i>	Gentianaceae	Native	Common	Tree
<i>Dalbergia candenatensis</i>	Fabaceae	Native	Common	Climber

Pulau Ubin Durian Appendix A - Flora Species List

<i>Davallia denticulata</i>	Davalliaceae	Native	Common	Epiphyte
<i>Derris trifoliata</i>	Fabaceae	Native	Common	Climber
<i>Dasymaschalon dasymaschalum</i>	Annonaceae	Native	Critically Endangered	Shrub
<i>Dianella ensifolia</i>	Hemerocallidaceae	Native	Common	Shrub
<i>Dieffenbachia seguine</i> var. <i>seguine</i>	Araceae	Exotic	-	Herb
<i>Dillenia suffruticosa</i>	Dilleniaceae	Native	Common	Shrub
<i>Dolichandrone spathacea</i>	Bignoniaceae	Native	Critically Endangered	Tree
<i>Dracaena braunii</i>	Ruscaceae	Exotic	-	Shrub
<i>Dracaena reflexa</i>	Ruscaceae	Exotic	-	Shrub
<i>Dracaena surculosa</i>	Ruscaceae	Exotic	-	Shrub
<i>Durio zibethinus</i>	Malvaceae	Exotic	-	Tree
<i>Echinochloa colona</i>	Poaceae	Native	Common	Herb
<i>Eclipta prostrata</i>	Asteraceae	Exotic	-	Herb
<i>Elaeis guineensis</i>	Arecaceae	Exotic	-	Tree
<i>Elaeocarpus pedunculatus</i>	Elaeocarpaceae	Native	Common	Tree
<i>Elephantopus mollis</i>	Asteraceae	Exotic	-	Tree
<i>Embelia ribes</i>	Myrsinaceae	Native	Common	Climber
<i>Erycibe tomentosa</i>	Convolvulaceae	Native	Common	Climber
<i>Eulophia graminea</i>	Orchidaceae	Cryptogenic	-	Herb
<i>Excoecaria agallocha</i>	Euphorbiaceae	Native	Common	Tree
<i>Falcataria falcata</i>	Fabaceae	Exotic	-	Tree
<i>Ficus caulocarpa</i>	Moraceae	Native	Endangered	Strangler
<i>Ficus</i> cf. <i>stricta</i>	Moraceae	Native	Critically Endangered	Tree
<i>Ficus microcarpa</i>	Moraceae	Native	Common	Tree
<i>Ficus religiosa</i>	Moraceae	Exotic	-	Tree
<i>Ficus variegata</i>	Moraceae	Native	Common	Tree
<i>Fimbristylis acuminata</i>	Cyperaceae	Native	Common	Herb
<i>Fimbristylis dichotoma</i>	Cyperaceae	Native	Common	Shrub
<i>Flagellaria indica</i>	Flagellariaceae	Native	Common	Climber
<i>Flemingia strobilifera</i>	Fabaceae	Native	Critically Endangered	Shrub
<i>Glochidion zeylanicum</i> var. <i>zeylanicum</i>	Phyllanthaceae	Native	Vulnerable	Tree
<i>Gnetum gnemon</i> var. <i>gnemon</i> *	Gnetaceae	Native	Critically Endangered	Tree
<i>Gnetum</i> sp. (Climber)	Gnetaceae	Native	Critically Endangered	Climber
<i>Grona heterocarpos</i> var. <i>strigosa</i>	Fabaceae	Native	Vulnerable	Shrub
<i>Guioa pleuropteris</i>	Sapindaceae	Native	Vulnerable	Tree
<i>Guioa pubescens</i>	Sapindaceae	Native	Vulnerable	Tree
<i>Gynochthodes coriacea</i>	Rubiaceae	Native	Common	Climber
<i>Gynochthodes rigida</i>	Rubiaceae	Native	Vulnerable	Climber
<i>Gynochthodes umbellata</i>	Rubiaceae	Native	Common	Climber
<i>Halophila ovalis</i>	Hydrocharitaceae	Native	Common	Seagrass
<i>Spermacoce remota</i>	Rubiaceae	Exotic	-	Herb
<i>Hevea brasiliensis</i>	Euphorbiaceae	Exotic	-	Tree
<i>Hibiscus tiliaceus</i>	Malvaceae	Native	Common	Tree
<i>Hoya diversifolia</i>	Apocynaceae	Native	Vulnerable	Climber
<i>Ilex cymosa</i>	Aquifoliaceae	Native	Common	Tree
<i>Indorouchera griffithiana</i>	Linaceae	Native	Common	Climber
<i>Isachne globosa</i>	Poaceae	Native	Common	Herb
<i>Ixora congesta</i>	Rubiaceae	Native	Common	Shrub
<i>Ixora lobbii</i> var. <i>lobbii</i>	Rubiaceae	Native	Endangered	Tree
<i>Knema corticosa</i>	Myristicaceae	Native	Vulnerable	Tree
<i>Leea indica</i>	Vitaceae	Native	Common	Tree
<i>Lepisanthes rubiginosa</i>	Sapindaceae	Native	Common	Tree
<i>Licuala spinosa</i>	Arecaceae	Native	Vulnerable	Shrub
<i>Limacia scandens</i>	Menispermaceae	Native	Vulnerable	Climber
<i>Lindernia diffusa</i>	Linderniaceae	Exotic	-	Herb
<i>Litsea elliptica</i>	Lauraceae	Native	Common	Tree
<i>Litsea myristicifolia</i>	Lauraceae	Native	Critically Endangered	Tree
<i>Lumnitzera littorea</i>	Combretaceae	Native	Endangered	Tree
<i>Lumnitzera racemosa</i>	Combretaceae	Native	Endangered	Tree
<i>Lygodium flexuosum</i>	Schizaeaceae	Native	Common	Climber
<i>Lygodium longifolium</i>	Schizaeaceae	Native	Common	Climber
<i>Macaranga gigantea</i>	Euphorbiaceae	Native	Common	Tree
<i>Macaranga heynei</i>	Euphorbiaceae	Native	Common	Tree
<i>Macaranga hypoleuca</i>	Euphorbiaceae	Native	Common	Tree

Pulau Ubin Durian Appendix A - Flora Species List

<i>Manihot carthagenensis</i> ssp. <i>glaziovii</i>	Euphorbiaceae	Exotic	-	Tree
<i>Melanthera biflora</i>	Asteraceae	Native	Common	Shrub
<i>Melastoma malabathricum</i>	Melastomataceae	Native	Common	Tree
<i>Memecylon edule</i> var. <i>edule</i>	Melastomataceae	Native	Endangered	Tree
<i>Mesosphaerum suaveolens</i>	Lamiaceae	Exotic	-	Shrub
<i>Miconia dependens</i>	Melastomataceae	Exotic	-	Shrub
<i>Mikania micrantha</i>	Asteraceae	Exotic	-	Climber
<i>Mimosa diplotricha</i>	Fabaceae	Exotic	-	Shrub
<i>Mimosa pigra</i>	Fabaceae	Exotic	-	Shrub
<i>Moeris debilis</i>	Phyllanthaceae	Exotic	-	Herb
<i>Neolitsea cassia</i>	Lauraceae	Native	Vulnerable	Tree
<i>Nephelium lappaceum</i> var. <i>lappaceum</i>	Sapindaceae	Cryptogenic	-	Tree
<i>Nypa fruticans</i>	Arecaceae	Native	Vulnerable	Shrub
<i>Oxyceros longiflorus</i>	Rubiaceae	Native	Vulnerable	Climber
<i>Parkia speciosa</i>	Fabaceae	Native	Vulnerable	Tree
<i>Paspalum conjugatum</i>	Poaceae	Exotic	-	Herb
<i>Passiflora laurifolia</i>	Passifloraceae	Exotic	-	Climber
<i>Pinanga cultivar</i>	Arecaceae	Exotic	-	Shrub
<i>Piper sarmentosum</i>	Piperaceae	Native	Common	Climber
<i>Pityrogramma calomelanos</i>	Adiantaceae	Exotic	-	Herb
<i>Planchonella obovata</i>	Sapotaceae	Native	Vulnerable	Tree
<i>Praxelis clematidea</i>	Asteraceae	Exotic	-	Herb
<i>Premna serratifolia</i>	Lamiaceae	Native	Common	Tree
<i>Pteris multifida</i>	Pteridaceae	Exotic	-	Herb
<i>Pteris semipinnata</i>	Pteridaceae	Exotic	-	Herb
<i>Ptychosperma macarthurii</i>	Arecaceae	Exotic	-	Tree
<i>Pyrrosia longifolia</i>	Polypodiaceae	Native	Common	Epiphyte
<i>Rhizophora apiculata</i>	Rhizophoraceae	Native	Common	Tree
<i>Rhizophora mucronata</i>	Rhizophoraceae	Native	Common	Tree
<i>Rhodamnia cinerea</i>	Myrtaceae	Native	Common	Tree
<i>Ruellia repens</i>	Acanthaceae	Cryptogenic	-	Shrub
<i>Sandoricum koetjape</i>	Meliaceae	Native	Endangered	Tree
<i>Synostemon bacciformis</i>	Phyllanthaceae	Native	Critically Endangered	Herb
<i>Scleria levis</i>	Cyperaceae	Native	Common	Herb
<i>Scoparia dulcis</i>	Scrophulariaceae	Exotic	-	Herb
<i>Scyphiphora hydrophylacea</i>	Rubiaceae	Native	Endangered	Tree
<i>Sida acuta</i>	Malvaceae	Exotic	-	Shrub
<i>Solanum torvum</i>	Solanaceae	Exotic	-	Shrub
<i>Sonneratia alba</i>	Lythraceae	Native	Common	Tree
<i>Spathodea campanulata</i>	Bignoniaceae	Exotic	-	Tree
<i>Sporobolus indicus</i>	Poaceae	Native	Common	Herb
<i>Stachytarpheta jamaicensis</i>	Verbenaceae	Exotic	-	Shrub
<i>Stenochlaena palustris</i>	Blechnaceae	Native	Common	Climber
<i>Suregada glomerulata</i>	Euphorbiaceae	Native	Critically Endangered	Shrub
<i>Symplocos fasciculata</i>	Symplocaceae	Native	Vulnerable	Tree
<i>Syzygium cerasiforme</i>	Myrtaceae	Native	Common	Tree
<i>Syzygium malaccense</i>	Myrtaceae	Exotic	-	Tree
<i>Syzygium polyanthum</i> *	Myrtaceae	Native	Common	Tree
<i>Syzygium pycnanthum</i>	Myrtaceae	Native	Critically Endangered	Tree
<i>Syzygium syzygioides</i>	Myrtaceae	Native	Vulnerable	Tree
<i>Taenitis blechnoides</i>	Pteridaceae	Native	Common	Climber
<i>Tarenna fragrans</i>	Rubiaceae	Native	Endangered	Shrub
<i>Terminalia catappa</i>	Combretaceae	Native	Common	Tree
<i>Tetracera indica</i>	Dilleniaceae	Native	Common	Climber
<i>Trema cannabina</i>	Cannabaceae	Native	Common	Tree
<i>Trema tomentosa</i>	Cannabaceae	Native	Vulnerable	Shrub
<i>Triadica cochinchinensis</i>	Euphorbiaceae	Native	Common	Tree
<i>Tristellateia australasiae</i>	Malpighiaceae	Native	Endangered	Climber
<i>Turnera subulata</i>	Turneraceae	Exotic	-	Herb
<i>Utania nervosa</i>	Gentianaceae	Native	Vulnerable	Tree
<i>Vitex pinnata</i>	Lamiaceae	Native	Common	Tree
<i>Wrightia religiosa</i>	Apocynaceae	Exotic	-	Shrub
<i>Xenostegia tridentata</i>	Convolvulaceae	Native	Common	Climber
<i>Ximenia americana</i>	Olcaceae	Native	Common	Shrub

Pulau Ubin Durian Appendix A - Flora Species List

<i>Xylocarpus granatum</i>	Meliaceae	Native	Common	Tree
<i>Zingiber officinale</i>	Zingiberaceae	Exotic	-	Herb
<i>Ischaemum muticum</i>	Poaceae	Native	Common	Herb
<i>Leucaena leucocephala</i>	Fabaceae	Exotic	-	Tree

**Planted or escaped from cultivation*

Appendix B
True Mangrove Species
List

Species	Family	National Status	Habit	Recorded on Pulau Ubin?	Recorded in this study?			
					Mamam Beach	Noordin Beach/Sungei Besar	Sungei Jelutong	Sungei Durian
<i>Acanthus ebracteatus</i>	Acanthaceae	Vulnerable	Shrub	Yes	No	No	No	No
<i>Acanthus ilicifolius</i>	Acanthaceae	Common	Shrub	Yes	No	No	No	No
<i>Acanthus volubilis</i>	Acanthaceae	Vulnerable	Shrub	Yes	Yes	No	No	No
<i>Acrostichum aureum</i>	Pteridaceae	Common	herb	Yes	Yes	Yes	Yes	Yes
<i>Acrostichum speciosum</i>	Pteridaceae	Common	herb	Yes	Yes	Yes	Yes	No
<i>Aegiceras corniculatum</i>	Myrsinaceae	Endangered	Tree	Yes	No	No	No	No
<i>Avicennia alba</i>	Acanthaceae	Common	Tree	Yes	Yes	Yes	Yes	Yes
<i>Avicennia marina ssp. marina</i>	Acanthaceae	Critically endangered	Tree	No	No	No	No	No
<i>Avicennia officinalis</i>	Acanthaceae	Common	Tree	Yes	Yes	Yes	Yes	Yes
<i>Avicennia rumphiana</i>	Acanthaceae	Common	Tree	Yes	Yes	Yes	Yes	Yes
<i>Brownlowia argentata</i>	Malvaceae	Extinct	Shrub	No	No	No	No	No
<i>Brownlowia tersa</i>	Malvaceae	Endangered	Shrub	Yes	No	No	No	No
<i>Bruguiera cylindrica</i>	Rhizophoraceae	Common	Tree	Yes	Yes	Yes	Yes	Yes
<i>Bruguiera gymnorhiza</i>	Rhizophoraceae	Common	Tree	Yes	Yes	Yes	Yes	Yes
<i>Bruguiera hainesii</i>	Rhizophoraceae	Critically endangered	Tree	Yes	No	Yes	Yes	No
<i>Bruguiera parviflora</i>	Rhizophoraceae	Endangered	Tree	Yes	No	Yes	No	No
<i>Bruguiera sexangula</i>	Rhizophoraceae	Critically endangered	Tree	Yes	No	No	No	No
<i>Ceriops tagal</i>	Rhizophoraceae	Vulnerable	Tree	Yes	No	Yes	Yes	Yes
<i>Ceriops zippeliana</i>	Rhizophoraceae	Endangered	Tree	Yes	Yes	Yes	Yes	Yes
<i>Dolichandrone spathacea</i>	Bignoniaceae	Critically endangered	Tree	Yes	No	Yes	No	Yes
<i>Excoecaria agallocha</i>	Euphorbiaceae	Common	Tree	Yes	Yes	Yes	Yes	Yes
<i>Heritiera littoralis</i>	Malvaceae	Endangered	Tree	Yes	No	Yes	Yes	No
<i>Kandelia candel</i>	Rhizophoraceae	Critically endangered	Shrub	Yes (planted)	No	No	No	No
<i>Lumnitzera littorea</i>	Combretaceae	Endangered	Tree	Yes	No	Yes	Yes	Yes
<i>Lumnitzera racemosa</i>	Combretaceae	Endangered	Tree	Yes	Yes	Yes	Yes	Yes
<i>Nypa fruticans</i>	Arecaceae	Vulnerable	Shrub	Yes	No	Yes	No	Yes
<i>Pemphis acidula</i>	Lythraceae	Critically endangered	Shrub	Yes (planted)	No	No	No	No
<i>Rhizophora apiculata</i>	Rhizophoraceae	Common	Tree	Yes	Yes	Yes	Yes	Yes
<i>Rhizophora mucronata</i>	Rhizophoraceae	Common	Tree	Yes	Yes	Yes	Yes	Yes
<i>Rhizophora stylosa</i>	Rhizophoraceae	Vulnerable	Tree	Yes	No	No	No	No
<i>Scyphiphora hydrophyllacea</i>	Rubiaceae	Endangered	Tree	Yes	Yes	Yes	Yes	Yes
<i>Sonneratia alba</i>	Lythraceae	Common	Tree	Yes	Yes	Yes	Yes	Yes
<i>Sonneratia caseolaris</i>	Lythraceae	Critically endangered	Tree	Yes	Yes	No	No	No
<i>Sonneratia ovata</i>	Lythraceae	Critically endangered	Tree	Yes	No	No	No	No
<i>Xylocarpus granatum</i>	Meliaceae	Common	Tree	Yes	Yes	Yes	Yes	Yes
<i>Xylocarpus moluccensis</i>	Meliaceae	Endangered	Tree	Yes	Yes	Yes	Yes	No
<i>Rhizophora x lamarkii</i>	Rhizophoraceae	N/A	Tree	Yes	No	No	No	No

Appendix C
Locations of Plants of
Conservation Significance

Pulau Ubin Durian Appendix C - Locations of Plants of Conservation Significance

Species	Family	National Status	Habit	Latitude	Longitude
<i>Antidesma velutinosum</i>	Phyllanthaceae	Endangered	Tree	1.408611	103.975135
<i>Antidesma velutinosum</i>	Phyllanthaceae	Endangered	Tree	1.408545	103.975137
<i>Antidesma velutinosum</i>	Phyllanthaceae	Endangered	Tree	1.408414	103.975155
<i>Antidesma velutinosum</i>	Phyllanthaceae	Endangered	Tree	1.408253	103.975132
<i>Antidesma velutinosum</i>	Phyllanthaceae	Endangered	Tree	1.408144	103.975062
<i>Antidesma velutinosum</i>	Phyllanthaceae	Endangered	Tree	1.408032	103.975116
<i>Antidesma velutinosum</i>	Phyllanthaceae	Endangered	Tree	1.407903	103.975154
<i>Antidesma velutinosum</i>	Phyllanthaceae	Endangered	Tree	1.408019	103.975237
<i>Antidesma velutinosum</i>	Phyllanthaceae	Endangered	Tree	1.407953	103.975277
<i>Antidesma velutinosum</i>	Phyllanthaceae	Endangered	Tree	1.408258	103.975455
<i>Antidesma velutinosum</i>	Phyllanthaceae	Endangered	Tree	1.408314	103.975427
<i>Antidesma velutinosum</i>	Phyllanthaceae	Endangered	Tree	1.408445	103.975444
<i>Antidesma velutinosum</i>	Phyllanthaceae	Endangered	Tree	1.408522	103.97541
<i>Antidesma velutinosum</i>	Phyllanthaceae	Endangered	Tree	1.408473	103.975291
<i>Antidesma velutinosum</i>	Phyllanthaceae	Endangered	Tree	1.408379	103.97524
<i>Antidesma velutinosum</i>	Phyllanthaceae	Endangered	Tree	1.408305	103.975238
<i>Antidesma velutinosum</i>	Phyllanthaceae	Endangered	Tree	1.408275	103.974936
<i>Antidesma velutinosum</i>	Phyllanthaceae	Endangered	Tree	1.41017	103.977687
<i>Antidesma velutinosum</i>	Phyllanthaceae	Endangered	Tree	1.408686	103.976971
<i>Antidesma velutinosum</i>	Phyllanthaceae	Endangered	Tree	1.408881	103.976641
<i>Antidesma velutinosum</i>	Phyllanthaceae	Endangered	Tree	1.408775	103.976787
<i>Antidesma velutinosum</i>	Phyllanthaceae	Endangered	Tree	1.408593	103.975838
<i>Antidesma velutinosum</i>	Phyllanthaceae	Endangered	Tree	1.408626	103.975766
<i>Antidesma velutinosum</i>	Phyllanthaceae	Endangered	Tree	1.408653	103.975777
<i>Antidesma velutinosum</i>	Phyllanthaceae	Endangered	Tree	1.408594	103.975482
<i>Antidesma velutinosum</i>	Phyllanthaceae	Endangered	Tree	1.408605	103.975414
<i>Antidesma velutinosum</i>	Phyllanthaceae	Endangered	Tree	1.408656	103.975273
<i>Antidesma velutinosum</i>	Phyllanthaceae	Endangered	Tree	1.408859	103.975588
<i>Antidesma velutinosum</i>	Phyllanthaceae	Endangered	Tree	1.409211	103.975965
<i>Antidesma velutinosum</i>	Phyllanthaceae	Endangered	Tree	1.408842	103.976416
<i>Antidesma velutinosum</i>	Phyllanthaceae	Endangered	Tree	1.408812	103.976112
<i>Antidesma velutinosum</i>	Phyllanthaceae	Endangered	Tree	1.408828	103.97691
<i>Antidesma velutinosum</i>	Phyllanthaceae	Endangered	Tree	1.409754	103.979195
<i>Antidesma velutinosum</i>	Phyllanthaceae	Endangered	Tree	1.410783	103.978136
<i>Antidesma velutinosum</i>	Phyllanthaceae	Endangered	Tree	1.410787	103.978124
<i>Antidesma velutinosum</i>	Phyllanthaceae	Endangered	Tree	1.410193	103.978139
<i>Antidesma velutinosum</i>	Phyllanthaceae	Endangered	Tree	1.409618	103.977878
<i>Archidendron ellipticum</i>	Fabaceae	Endangered	Tree	1.410193	103.978139
<i>Ardisia elliptica</i>	Myrsinaceae	Endangered	Tree	1.408386	103.975138
<i>Ardisia elliptica</i>	Myrsinaceae	Endangered	Tree	1.407953	103.975277
<i>Ardisia elliptica</i>	Myrsinaceae	Endangered	Tree	1.408247	103.975295
<i>Ardisia elliptica</i>	Myrsinaceae	Endangered	Tree	1.409828	103.977461
<i>Ardisia elliptica</i>	Myrsinaceae	Endangered	Tree	1.409398	103.977736
<i>Ardisia elliptica</i>	Myrsinaceae	Endangered	Tree	1.409144	103.977604
<i>Ardisia elliptica</i>	Myrsinaceae	Endangered	Tree	1.408899	103.977409
<i>Ardisia elliptica</i>	Myrsinaceae	Endangered	Tree	1.410604	103.978216
<i>Ardisia elliptica</i>	Myrsinaceae	Endangered	Tree	1.410355	103.978228
<i>Ardisia elliptica</i>	Myrsinaceae	Endangered	Tree	1.410396	103.978136
<i>Ardisia elliptica</i>	Myrsinaceae	Endangered	Tree	1.40999	103.978089
<i>Ardisia elliptica</i>	Myrsinaceae	Endangered	Tree	1.409668	103.978023
<i>Ardisia elliptica</i>	Myrsinaceae	Endangered	Tree	1.409537	103.977851

Pulau Ubin Durian Appendix C - Locations of Plants of Conservation Significance

<i>Ardisia elliptica</i>	Myrsinaceae	Endangered	Tree	1.409025	103.976603
<i>Ardisia elliptica</i>	Myrsinaceae	Endangered	Tree	1.408873	103.97675
<i>Ardisia elliptica</i>	Myrsinaceae	Endangered	Tree	1.408535	103.976446
<i>Ardisia elliptica</i>	Myrsinaceae	Endangered	Tree	1.408638	103.976611
<i>Ardisia elliptica</i>	Myrsinaceae	Endangered	Tree	1.408657	103.97658
<i>Ardisia elliptica</i>	Myrsinaceae	Endangered	Tree	1.40865	103.976285
<i>Ardisia elliptica</i>	Myrsinaceae	Endangered	Tree	1.408653	103.975777
<i>Ardisia elliptica</i>	Myrsinaceae	Endangered	Tree	1.408093	103.975688
<i>Ardisia elliptica</i>	Myrsinaceae	Endangered	Tree	1.408026	103.975692
<i>Ardisia elliptica</i>	Myrsinaceae	Endangered	Tree	1.408829	103.976444
<i>Ardisia elliptica</i>	Myrsinaceae	Endangered	Tree	1.408816	103.976128
<i>Ardisia elliptica</i>	Myrsinaceae	Endangered	Tree	1.408725	103.976371
<i>Ardisia elliptica</i>	Myrsinaceae	Endangered	Tree	1.408926	103.97683
<i>Ardisia elliptica</i>	Myrsinaceae	Endangered	Tree	1.407659	103.976102
<i>Ardisia elliptica</i>	Myrsinaceae	Endangered	Tree	1.40895	103.979358
<i>Ardisia elliptica</i>	Myrsinaceae	Endangered	Tree	1.408361	103.979661
<i>Ardisia elliptica</i>	Myrsinaceae	Endangered	Tree	1.410349	103.978803
<i>Ardisia elliptica</i>	Myrsinaceae	Endangered	Tree	1.410086	103.978767
<i>Ardisia elliptica</i>	Myrsinaceae	Endangered	Tree	1.409951	103.978803
<i>Ardisia elliptica</i>	Myrsinaceae	Endangered	Tree	1.409775	103.978884
<i>Ardisia elliptica</i>	Myrsinaceae	Endangered	Tree	1.409608	103.978817
<i>Ardisia elliptica</i>	Myrsinaceae	Endangered	Tree	1.409418	103.978834
<i>Ardisia elliptica</i>	Myrsinaceae	Endangered	Tree	1.410713	103.979308
<i>Ardisia elliptica</i>	Myrsinaceae	Endangered	Tree	18/3/22	18/3/22
<i>Ardisia elliptica</i>	Myrsinaceae	Endangered	Tree	1.410695	103.978434
<i>Ardisia elliptica</i>	Myrsinaceae	Endangered	Tree	1.411157	103.978182
<i>Barringtonia racemosa</i>	Lecythydaceae	Critically endangered	Tree	1.409491	103.979234
<i>Bridelia stipularis</i>	Phyllanthaceae	Vulnerable	Climber	1.407958	103.97595
<i>Bridelia stipularis</i>	Phyllanthaceae	Vulnerable	Climber	1.408343	103.97609
<i>Bridelia stipularis</i>	Phyllanthaceae	Vulnerable	Climber	1.410238	103.979258
<i>Calamus cf. erinaceus</i>	Arecaceae	Vulnerable	Climber	1.408693	103.979355
<i>Calophyllum inophyllum</i>	Calophyllaceae	Endangered	Tree	1.41063	103.978234
<i>Calophyllum inophyllum</i>	Calophyllaceae	Endangered	Tree	1.409037	103.979279
<i>Cansjera rheedii</i>	Opiliaceae	Vulnerable	Climber	1.409333	103.977278
<i>Cansjera rheedii</i>	Opiliaceae	Vulnerable	Climber	1.40878	103.975556
<i>Cansjera rheedii</i>	Opiliaceae	Vulnerable	Climber	1.408934	103.976902
<i>Cansjera rheedii</i>	Opiliaceae	Vulnerable	Climber	1.409411	103.977952
<i>Cansjera rheedii</i>	Opiliaceae	Vulnerable	Climber	1.410722	103.978338
<i>Cansjera rheedii</i>	Opiliaceae	Vulnerable	Climber	1.408854	103.979347
<i>Cansjera rheedii</i>	Opiliaceae	Vulnerable	Climber	1.408593	103.979431
<i>Ceriops sp.</i>	Rhizophoraceae	Endangered	Tree	1.408072	103.979459
<i>Ceriops sp.</i>	Rhizophoraceae	Endangered	Tree	1.408151	103.979284
<i>Ceriops sp.</i>	Rhizophoraceae	Endangered	Tree	1.408152	103.979136
<i>Ceriops tagal</i>	Rhizophoraceae	Vulnerable	Tree	1.407994	103.975808
<i>Ceriops tagal</i>	Rhizophoraceae	Vulnerable	Tree	1.410576	103.978492
<i>Ceriops tagal</i>	Rhizophoraceae	Vulnerable	Tree	1.409211	103.978472
<i>Ceriops tagal</i>	Rhizophoraceae	Vulnerable	Tree	1.408877	103.978453
<i>Ceriops tagal</i>	Rhizophoraceae	Vulnerable	Tree	1.408627	103.978486
<i>Ceriops zippeliana</i>	Rhizophoraceae	Endangered	Tree	1.408099	103.977408
<i>Ceriops zippeliana</i>	Rhizophoraceae	Endangered	Tree	1.408032	103.977427
<i>Ceriops zippeliana</i>	Rhizophoraceae	Endangered	Tree	1.408011	103.977462
<i>Ceriops zippeliana</i>	Rhizophoraceae	Endangered	Tree	1.407882	103.977517

Pulau Ubin Durian Appendix C - Locations of Plants of Conservation Significance

<i>Ceriops zippeliana</i>	Rhizophoraceae	Endangered	Tree	1.407834	103.977526
<i>Ceriops zippeliana</i>	Rhizophoraceae	Endangered	Tree	1.40792	103.978418
<i>Ceriops zippeliana</i>	Rhizophoraceae	Endangered	Tree	1.40778	103.97801
<i>Ceriops zippeliana</i>	Rhizophoraceae	Endangered	Tree	1.407729	103.977864
<i>Ceriops zippeliana</i>	Rhizophoraceae	Endangered	Tree	1.407722	103.977826
<i>Ceriops zippeliana</i>	Rhizophoraceae	Endangered	Tree	1.410536	103.978696
<i>Ceriops zippeliana</i>	Rhizophoraceae	Endangered	Tree	1.408234	103.979456
<i>Ceriops zippeliana</i>	Rhizophoraceae	Endangered	Tree	1.408222	103.979354
<i>Ceriops zippeliana</i>	Rhizophoraceae	Endangered	Tree	1.409256	103.97847
<i>Ceriops zippeliana</i>	Rhizophoraceae	Endangered	Tree	1.409187	103.978455
<i>Ceriops zippeliana</i>	Rhizophoraceae	Endangered	Tree	1.409042	103.978485
<i>Ceriops zippeliana</i>	Rhizophoraceae	Endangered	Tree	1.408762	103.978505
<i>Ceriops zippeliana</i>	Rhizophoraceae	Endangered	Tree	1.408513	103.978506
<i>Ceriops zippeliana</i>	Rhizophoraceae	Endangered	Tree	1.408567	103.978907
<i>Chassalia curviflora</i>	Rubiaceae	Vulnerable	Shrub	1.408386	103.975138
<i>Curculigo latifolia</i>	Hypoxidaceae	Vulnerable	Herb	1.408979	103.976976
<i>Cynometra ramiflora</i>	Fabaceae	Critically endangered	Tree	1.41072	103.979296
<i>Cynometra ramiflora</i>	Fabaceae	Critically endangered	Tree	1.410614	103.979258
<i>Cyrtococcum patens</i>	Poaceae	Vulnerable	Herb	1.408935	103.977054
<i>Cyrtococcum patens</i>	Poaceae	Vulnerable	Herb	1.409015	103.976361
<i>Cyrtococcum patens</i>	Poaceae	Vulnerable	Herb	1.408634	103.976653
<i>Cyrtococcum patens</i>	Poaceae	Vulnerable	Herb	1.408844	103.976396
<i>Dasymaschalon dasymaschalum</i>	Annonaceae	Critically endangered	Tree	1.408541	103.97514
<i>Dasymaschalon dasymaschalum</i>	Annonaceae	Critically endangered	Tree	1.408258	103.975455
<i>Dasymaschalon dasymaschalum</i>	Annonaceae	Critically endangered	Tree	1.409244	103.977254
<i>Dasymaschalon dasymaschalum</i>	Annonaceae	Critically endangered	Tree	1.409439	103.977358
<i>Dasymaschalon dasymaschalum</i>	Annonaceae	Critically endangered	Tree	1.40906	103.97632
<i>Dasymaschalon dasymaschalum</i>	Annonaceae	Critically endangered	Tree	1.408997	103.976353
<i>Dasymaschalon dasymaschalum</i>	Annonaceae	Critically endangered	Tree	1.408864	103.976666
<i>Dasymaschalon dasymaschalum</i>	Annonaceae	Critically endangered	Tree	1.408726	103.976703
<i>Dasymaschalon dasymaschalum</i>	Annonaceae	Critically endangered	Tree	1.408549	103.976549
<i>Dasymaschalon dasymaschalum</i>	Annonaceae	Critically endangered	Tree	1.408606	103.976039
<i>Dasymaschalon dasymaschalum</i>	Annonaceae	Critically endangered	Tree	1.408653	103.975777
<i>Dasymaschalon dasymaschalum</i>	Annonaceae	Critically endangered	Tree	1.40874	103.9758
<i>Dasymaschalon dasymaschalum</i>	Annonaceae	Critically endangered	Tree	1.409194	103.976092
<i>Dasymaschalon dasymaschalum</i>	Annonaceae	Critically endangered	Tree	1.4088	103.976038
<i>Dasymaschalon dasymaschalum</i>	Annonaceae	Critically endangered	Tree	1.408759	103.977116
<i>Dasymaschalon dasymaschalum</i>	Annonaceae	Critically endangered	Tree	1.408827	103.979335
<i>Dolichandrone spathacea</i>	Bignoniaceae	Critically endangered	Tree	1.409399	103.979096
<i>Ficus cf. stricta</i>	Moraceae	Critically endangered	Strangler	1.408554	103.976544
<i>Flemingia strobilifera</i>	Fabaceae	Critically endangered	Shrub	1.408845	103.97673
<i>Glochidion zeylanicum</i>	Phyllanthaceae	Vulnerable	Tree	1.41118	103.978126
<i>Gnetum sp. (Climber)</i>	Gnetaceae	Critically endangered	Climber	1.409537	103.977851
<i>Gnetum sp. (Climber)</i>	Gnetaceae	Critically endangered	Climber	1.409299	103.977131
<i>Gnetum sp. (Climber)</i>	Gnetaceae	Critically endangered	Climber	1.409522	103.977501
<i>Gnetum sp. (Climber)</i>	Gnetaceae	Critically endangered	Climber	1.409859	103.977556
<i>Gnetum sp. (Climber)</i>	Gnetaceae	Critically endangered	Climber	1.410474	103.977872
<i>Gnetum sp. (Climber)</i>	Gnetaceae	Critically endangered	Climber	1.409714	103.979228
<i>Gnetum sp. (Climber)</i>	Gnetaceae	Critically endangered	Climber	1.409338	103.97933
<i>Gnetum sp. (Climber)</i>	Gnetaceae	Critically endangered	Climber	1.408733	103.979321
<i>Gnetum sp. (Climber)</i>	Gnetaceae	Critically endangered	Climber	1.408683	103.975977
<i>Gnetum sp. (Climber)</i>	Gnetaceae	Critically endangered	Climber	1.408594	103.975774

Pulau Ubin Durian Appendix C - Locations of Plants of Conservation Significance

<i>Grona heterocarpus var. strigosa</i>	Fabaceae	Vulnerable	Shrub	1.40863	103.977319
<i>Guioa pleuropteris</i>	Sapindaceae	Vulnerable	Tree	1.410588	103.978245
<i>Guioa pubescens</i>	Sapindaceae	Vulnerable	Tree	1.410926	103.978345
<i>Gynochthodes rigida</i>	Rubiaceae	Vulnerable	Climber	1.408553	103.979516
<i>Gynochthodes rigida</i>	Rubiaceae	Vulnerable	Climber	1.410954	103.97836
<i>Hoya diversifolia</i>	Apocynaceae	Critically endangered	Epiphyte	1.410717	103.978424
<i>Hoya diversifolia</i>	Apocynaceae	Critically endangered	Epiphyte	1.409322	103.978824
<i>Ixora lobbii var. lobbii</i>	Rubiaceae	Endangered	Shrub	1.408611	103.975135
<i>Ixora lobbii var. lobbii</i>	Rubiaceae	Endangered	Shrub	1.408119	103.975083
<i>Ixora lobbii var. lobbii</i>	Rubiaceae	Endangered	Shrub	1.410552	103.977865
<i>Ixora lobbii var. lobbii</i>	Rubiaceae	Endangered	Shrub	1.40865	103.976184
<i>Ixora lobbii var. lobbii</i>	Rubiaceae	Endangered	Shrub	1.408641	103.976063
<i>Ixora lobbii var. lobbii</i>	Rubiaceae	Endangered	Shrub	1.408655	103.975861
<i>Ixora lobbii var. lobbii</i>	Rubiaceae	Endangered	Shrub	1.408807	103.97554
<i>Ixora lobbii var. lobbii</i>	Rubiaceae	Endangered	Shrub	1.408815	103.976434
<i>Ixora lobbii var. lobbii</i>	Rubiaceae	Endangered	Shrub	1.408886	103.976012
<i>Ixora lobbii var. lobbii</i>	Rubiaceae	Endangered	Shrub	1.408944	103.976007
<i>Ixora lobbii var. lobbii</i>	Rubiaceae	Endangered	Shrub	1.40892	103.976797
<i>Ixora lobbii var. lobbii</i>	Rubiaceae	Endangered	Shrub	1.410787	103.978124
<i>Ixora lobbii var. lobbii</i>	Rubiaceae	Endangered	Shrub	1.410753	103.978179
<i>Ixora lobbii var. lobbii</i>	Rubiaceae	Endangered	Shrub	1.408537	103.979513
<i>Knema corticosa</i>	Myristicaceae	Vulnerable	Tree	1.408541	103.97514
<i>Knema corticosa</i>	Myristicaceae	Vulnerable	Tree	1.408493	103.975212
<i>Knema corticosa</i>	Myristicaceae	Vulnerable	Tree	1.408291	103.975132
<i>Knema corticosa</i>	Myristicaceae	Vulnerable	Tree	1.408067	103.975098
<i>Knema corticosa</i>	Myristicaceae	Vulnerable	Tree	1.407903	103.975154
<i>Knema corticosa</i>	Myristicaceae	Vulnerable	Tree	1.408406	103.975441
<i>Knema corticosa</i>	Myristicaceae	Vulnerable	Tree	1.408528	103.975354
<i>Knema corticosa</i>	Myristicaceae	Vulnerable	Tree	1.408451	103.975258
<i>Knema corticosa</i>	Myristicaceae	Vulnerable	Tree	1.40825	103.97529
<i>Knema corticosa</i>	Myristicaceae	Vulnerable	Tree	1.40818	103.975221
<i>Knema corticosa</i>	Myristicaceae	Vulnerable	Tree	1.409134	103.97703
<i>Knema corticosa</i>	Myristicaceae	Vulnerable	Tree	1.409298	103.977187
<i>Knema corticosa</i>	Myristicaceae	Vulnerable	Tree	1.409304	103.977324
<i>Knema corticosa</i>	Myristicaceae	Vulnerable	Tree	1.409811	103.977519
<i>Knema corticosa</i>	Myristicaceae	Vulnerable	Tree	1.409919	103.977585
<i>Knema corticosa</i>	Myristicaceae	Vulnerable	Tree	1.410021	103.977556
<i>Knema corticosa</i>	Myristicaceae	Vulnerable	Tree	1.410153	103.977669
<i>Knema corticosa</i>	Myristicaceae	Vulnerable	Tree	1.410256	103.977606
<i>Knema corticosa</i>	Myristicaceae	Vulnerable	Tree	1.410229	103.977722
<i>Knema corticosa</i>	Myristicaceae	Vulnerable	Tree	1.410923	103.978379
<i>Knema corticosa</i>	Myristicaceae	Vulnerable	Tree	1.411027	103.978063
<i>Knema corticosa</i>	Myristicaceae	Vulnerable	Tree	1.41063	103.978234
<i>Knema corticosa</i>	Myristicaceae	Vulnerable	Tree	1.410551	103.978233
<i>Knema corticosa</i>	Myristicaceae	Vulnerable	Tree	1.410361	103.97821
<i>Knema corticosa</i>	Myristicaceae	Vulnerable	Tree	1.410174	103.978191
<i>Knema corticosa</i>	Myristicaceae	Vulnerable	Tree	1.410169	103.97808
<i>Knema corticosa</i>	Myristicaceae	Vulnerable	Tree	1.410213	103.978026
<i>Knema corticosa</i>	Myristicaceae	Vulnerable	Tree	1.409953	103.978035
<i>Knema corticosa</i>	Myristicaceae	Vulnerable	Tree	1.409827	103.978074
<i>Knema corticosa</i>	Myristicaceae	Vulnerable	Tree	1.409726	103.978023
<i>Knema corticosa</i>	Myristicaceae	Vulnerable	Tree	1.409698	103.978018

Pulau Ubin Durian Appendix C - Locations of Plants of Conservation Significance

<i>Knema corticosa</i>	Myristicaceae	Vulnerable	Tree	1.409664	103.978095
<i>Knema corticosa</i>	Myristicaceae	Vulnerable	Tree	1.409656	103.977926
<i>Knema corticosa</i>	Myristicaceae	Vulnerable	Tree	1.409572	103.977876
<i>Knema corticosa</i>	Myristicaceae	Vulnerable	Tree	1.40942	103.977744
<i>Knema corticosa</i>	Myristicaceae	Vulnerable	Tree	1.40926	103.977659
<i>Knema corticosa</i>	Myristicaceae	Vulnerable	Tree	1.409048	103.977324
<i>Knema corticosa</i>	Myristicaceae	Vulnerable	Tree	1.408923	103.977395
<i>Knema corticosa</i>	Myristicaceae	Vulnerable	Tree	1.409063	103.977044
<i>Knema corticosa</i>	Myristicaceae	Vulnerable	Tree	1.408897	103.976602
<i>Knema corticosa</i>	Myristicaceae	Vulnerable	Tree	1.408875	103.976604
<i>Knema corticosa</i>	Myristicaceae	Vulnerable	Tree	1.408712	103.976702
<i>Knema corticosa</i>	Myristicaceae	Vulnerable	Tree	1.408577	103.976667
<i>Knema corticosa</i>	Myristicaceae	Vulnerable	Tree	1.408588	103.976687
<i>Knema corticosa</i>	Myristicaceae	Vulnerable	Tree	1.40861	103.976751
<i>Knema corticosa</i>	Myristicaceae	Vulnerable	Tree	1.408638	103.976611
<i>Knema corticosa</i>	Myristicaceae	Vulnerable	Tree	1.408635	103.976506
<i>Knema corticosa</i>	Myristicaceae	Vulnerable	Tree	1.40863	103.976457
<i>Knema corticosa</i>	Myristicaceae	Vulnerable	Tree	1.408572	103.976388
<i>Knema corticosa</i>	Myristicaceae	Vulnerable	Tree	1.408655	103.97628
<i>Knema corticosa</i>	Myristicaceae	Vulnerable	Tree	1.40869	103.976233
<i>Knema corticosa</i>	Myristicaceae	Vulnerable	Tree	1.408655	103.975861
<i>Knema corticosa</i>	Myristicaceae	Vulnerable	Tree	1.408736	103.975577
<i>Knema corticosa</i>	Myristicaceae	Vulnerable	Tree	1.408653	103.975366
<i>Knema corticosa</i>	Myristicaceae	Vulnerable	Tree	1.408693	103.975264
<i>Knema corticosa</i>	Myristicaceae	Vulnerable	Tree	1.408852	103.975593
<i>Knema corticosa</i>	Myristicaceae	Vulnerable	Tree	1.408914	103.975665
<i>Knema corticosa</i>	Myristicaceae	Vulnerable	Tree	1.409151	103.975946
<i>Knema corticosa</i>	Myristicaceae	Vulnerable	Tree	1.409194	103.976092
<i>Knema corticosa</i>	Myristicaceae	Vulnerable	Tree	1.408904	103.976482
<i>Knema corticosa</i>	Myristicaceae	Vulnerable	Tree	1.408816	103.976294
<i>Knema corticosa</i>	Myristicaceae	Vulnerable	Tree	1.408934	103.976024
<i>Knema corticosa</i>	Myristicaceae	Vulnerable	Tree	1.408994	103.975954
<i>Knema corticosa</i>	Myristicaceae	Vulnerable	Tree	1.408884	103.976768
<i>Knema corticosa</i>	Myristicaceae	Vulnerable	Tree	1.408828	103.97691
<i>Knema corticosa</i>	Myristicaceae	Vulnerable	Tree	1.408773	103.976927
<i>Knema corticosa</i>	Myristicaceae	Vulnerable	Tree	1.408735	103.976947
<i>Knema corticosa</i>	Myristicaceae	Vulnerable	Tree	1.408728	103.976975
<i>Knema corticosa</i>	Myristicaceae	Vulnerable	Tree	1.408759	103.977116
<i>Knema corticosa</i>	Myristicaceae	Vulnerable	Tree	1.408782	103.977201
<i>Knema corticosa</i>	Myristicaceae	Vulnerable	Tree	1.408655	103.977021
<i>Knema corticosa</i>	Myristicaceae	Vulnerable	Tree	1.409466	103.979227
<i>Knema corticosa</i>	Myristicaceae	Vulnerable	Tree	1.408609	103.979462
<i>Knema corticosa</i>	Myristicaceae	Vulnerable	Tree	1.4086	103.979486
<i>Knema corticosa</i>	Myristicaceae	Vulnerable	Tree	1.410783	103.978136
<i>Licuala spinosa</i>	Arecaceae	Vulnerable	Shrub	1.410099	103.97796
<i>Licuala spinosa</i>	Arecaceae	Vulnerable	Shrub	1.408667	103.975957
<i>Licuala spinosa</i>	Arecaceae	Vulnerable	Shrub	1.408824	103.976419
<i>Licuala spinosa</i>	Arecaceae	Vulnerable	Shrub	1.410037	103.979224
<i>Licuala spinosa</i>	Arecaceae	Vulnerable	Shrub	1.41063	103.978234
<i>Licuala spinosa</i>	Arecaceae	Vulnerable	Shrub	1.410319	103.978222
<i>Licuala spinosa</i>	Arecaceae	Vulnerable	Shrub	1.410199	103.978208
<i>Licuala spinosa</i>	Arecaceae	Vulnerable	Shrub	1.41011	103.978154

Pulau Ubin Durian Appendix C - Locations of Plants of Conservation Significance

<i>Licuala spinosa</i>	Arecaceae	Vulnerable	Shrub	1.409989	103.978064
<i>Licuala spinosa</i>	Arecaceae	Vulnerable	Shrub	1.40973	103.978038
<i>Licuala spinosa</i>	Arecaceae	Vulnerable	Shrub	1.409226	103.977624
<i>Licuala spinosa</i>	Arecaceae	Vulnerable	Shrub	1.409381	103.977306
<i>Limacia scandens</i>	Menispermaceae	Vulnerable	Climber	1.409041	103.976676
<i>Litsea myristicifolia</i>	Lauraceae	Critically endangered	Tree	1.408252	103.975231
<i>Litsea myristicifolia</i>	Lauraceae	Critically endangered	Tree	1.409548	103.977372
<i>Litsea myristicifolia</i>	Lauraceae	Critically endangered	Tree	1.409949	103.977609
<i>Litsea myristicifolia</i>	Lauraceae	Critically endangered	Tree	1.410245	103.977659
<i>Litsea myristicifolia</i>	Lauraceae	Critically endangered	Tree	1.410247	103.977678
<i>Litsea myristicifolia</i>	Lauraceae	Critically endangered	Tree	1.410572	103.977867
<i>Litsea myristicifolia</i>	Lauraceae	Critically endangered	Tree	1.410615	103.977871
<i>Litsea myristicifolia</i>	Lauraceae	Critically endangered	Tree	1.408873	103.976731
<i>Litsea myristicifolia</i>	Lauraceae	Critically endangered	Tree	1.408874	103.975988
<i>Litsea myristicifolia</i>	Lauraceae	Critically endangered	Tree	1.410588	103.978245
<i>Litsea myristicifolia</i>	Lauraceae	Critically endangered	Tree	1.410479	103.978219
<i>Litsea myristicifolia</i>	Lauraceae	Critically endangered	Tree	1.410403	103.978231
<i>Litsea myristicifolia</i>	Lauraceae	Critically endangered	Tree	1.410312	103.978149
<i>Litsea myristicifolia</i>	Lauraceae	Critically endangered	Tree	1.410447	103.978076
<i>Litsea myristicifolia</i>	Lauraceae	Critically endangered	Tree	1.410485	103.978035
<i>Litsea myristicifolia</i>	Lauraceae	Critically endangered	Tree	1.410091	103.978047
<i>Litsea myristicifolia</i>	Lauraceae	Critically endangered	Tree	1.409889	103.978029
<i>Litsea myristicifolia</i>	Lauraceae	Critically endangered	Tree	1.409398	103.977687
<i>Litsea myristicifolia</i>	Lauraceae	Critically endangered	Tree	1.409296	103.977703
<i>Lumnitzera littorea</i>	Combretaceae	Endangered	Tree	1.408126	103.979065
<i>Lumnitzera littorea</i>	Combretaceae	Endangered	Tree	1.407817	103.978323
<i>Lumnitzera littorea</i>	Combretaceae	Endangered	Tree	1.408272	103.978479
<i>Lumnitzera littorea</i>	Combretaceae	Endangered	Tree	1.408202	103.978473
<i>Lumnitzera littorea</i>	Combretaceae	Endangered	Tree	1.409204	103.978846
<i>Lumnitzera littorea</i>	Combretaceae	Endangered	Tree	1.407918	103.978871
<i>Lumnitzera racemosa</i>	Combretaceae	Endangered	Tree	1.408386	103.978456
<i>Memecylon edule var. edule</i>	Melastomataceae	Endangered	Tree	1.40993	103.97752
<i>Memecylon edule var. edule</i>	Melastomataceae	Endangered	Tree	1.410604	103.978216
<i>Memecylon edule var. edule</i>	Melastomataceae	Endangered	Tree	1.408768	103.97705
<i>Memecylon edule var. edule</i>	Melastomataceae	Endangered	Tree	1.409173	103.979298
<i>Neolitsea cassia</i>	Lauraceae	Vulnerable	Tree	1.408565	103.976425
<i>Neolitsea cassia</i>	Lauraceae	Vulnerable	Tree	1.408873	103.979344
<i>Nypa fruticans</i>	Arecaceae	Vulnerable	Tree	1.408538	103.976438
<i>Nypa fruticans</i>	Arecaceae	Vulnerable	Tree	1.408509	103.976363
<i>Nypa fruticans</i>	Arecaceae	Vulnerable	Tree	1.408574	103.976431
<i>Nypa fruticans</i>	Arecaceae	Vulnerable	Tree	1.408688	103.976218
<i>Nypa fruticans</i>	Arecaceae	Vulnerable	Tree	1.408639	103.976154
<i>Nypa fruticans</i>	Arecaceae	Vulnerable	Tree	1.408594	103.976033
<i>Nypa fruticans</i>	Arecaceae	Vulnerable	Tree	1.408249	103.97561
<i>Nypa fruticans</i>	Arecaceae	Vulnerable	Tree	1.408193	103.975606
<i>Nypa fruticans</i>	Arecaceae	Vulnerable	Tree	1.408147	103.975663
<i>Nypa fruticans</i>	Arecaceae	Vulnerable	Tree	1.410632	103.978643
<i>Nypa fruticans</i>	Arecaceae	Vulnerable	Tree	1.410543	103.979075
<i>Nypa fruticans</i>	Arecaceae	Vulnerable	Tree	1.410438	103.979122
<i>Nypa fruticans</i>	Arecaceae	Vulnerable	Tree	1.408305	103.979584
<i>Nypa fruticans</i>	Arecaceae	Vulnerable	Tree	1.40804	103.978714
<i>Oxyceros longiflorus</i>	Rubiaceae	Vulnerable	Climber	1.40853	103.976532

Pulau Ubin Durian Appendix C - Locations of Plants of Conservation Significance

<i>Oxyceros longiflorus</i>	Rubiaceae	Vulnerable	Climber	1.408612	103.97613
<i>Oxyceros longiflorus</i>	Rubiaceae	Vulnerable	Climber	1.408785	103.976069
<i>Oxyceros longiflorus</i>	Rubiaceae	Vulnerable	Climber	1.408786	103.977229
<i>Oxyceros longiflorus</i>	Rubiaceae	Vulnerable	Climber	1.408449	103.976319
<i>Oxyceros longiflorus</i>	Rubiaceae	Vulnerable	Climber	1.408357	103.976029
<i>Oxyceros longiflorus</i>	Rubiaceae	Vulnerable	Climber	1.409264	103.977792
<i>Oxyceros longiflorus</i>	Rubiaceae	Vulnerable	Climber	1.41007	103.978248
<i>Oxyceros longiflorus</i>	Rubiaceae	Vulnerable	Climber	1.410934	103.978192
<i>Oxyceros longiflorus</i>	Rubiaceae	Vulnerable	Climber	1.410394	103.979137
<i>Oxyceros longiflorus</i>	Rubiaceae	Vulnerable	Climber	1.409437	103.979198
<i>Oxyceros longiflorus</i>	Rubiaceae	Vulnerable	Climber	1.409391	103.979166
<i>Oxyceros longiflorus</i>	Rubiaceae	Vulnerable	Climber	1.40967	103.978205
<i>Oxyceros longiflorus</i>	Rubiaceae	Vulnerable	Climber	1.410349	103.978803
<i>Oxyceros longiflorus</i>	Rubiaceae	Vulnerable	Climber	1.410031	103.978808
<i>Oxyceros longiflorus</i>	Rubiaceae	Vulnerable	Climber	1.40979	103.978841
<i>Oxyceros longiflorus</i>	Rubiaceae	Vulnerable	Climber	1.409608	103.978817
<i>Oxyceros longiflorus</i>	Rubiaceae	Vulnerable	Climber	1.408646	103.978879
<i>Oxyceros longiflorus</i>	Rubiaceae	Vulnerable	Climber	1.411084	103.978326
<i>Parkia speciosa</i>	Fabaceae	Vulnerable	Tree	1.409103	103.977081
<i>Planchonella obovata</i>	Sapotaceae	Vulnerable	Tree	1.409315	103.977704
<i>Planchonella obovata</i>	Sapotaceae	Vulnerable	Tree	1.408872	103.977314
<i>Planchonella obovata</i>	Sapotaceae	Vulnerable	Tree	1.408547	103.976516
<i>Planchonella obovata</i>	Sapotaceae	Vulnerable	Tree	1.408883	103.975382
<i>Planchonella obovata</i>	Sapotaceae	Vulnerable	Tree	1.408904	103.976482
<i>Planchonella obovata</i>	Sapotaceae	Vulnerable	Tree	1.408798	103.976086
<i>Planchonella obovata</i>	Sapotaceae	Vulnerable	Tree	1.409469	103.979255
<i>Planchonella obovata</i>	Sapotaceae	Vulnerable	Tree	1.409042	103.979293
<i>Planchonella obovata</i>	Sapotaceae	Vulnerable	Tree	1.408327	103.97963
<i>Sandoricum koetjape</i>	Meliaceae	Endangered	Tree	1.408243	103.975139
<i>Sandoricum koetjape</i>	Meliaceae	Endangered	Tree	1.409846	103.977461
<i>Sandoricum koetjape</i>	Meliaceae	Endangered	Tree	1.409859	103.977556
<i>Sandoricum koetjape</i>	Meliaceae	Endangered	Tree	1.40874	103.9758
<i>Sandoricum koetjape</i>	Meliaceae	Endangered	Tree	1.410869	103.978169
<i>Sandoricum koetjape</i>	Meliaceae	Endangered	Tree	1.410793	103.979367
<i>Synostemon bacciformis</i>	Phyllanthaceae	Critically endangered	Herb	1.407567	103.977589
<i>Synostemon bacciformis</i>	Phyllanthaceae	Critically endangered	Herb	1.407573	103.977633
<i>Synostemon bacciformis</i>	Phyllanthaceae	Critically endangered	Herb	1.407694	103.977782
<i>Scyphiphora hydrophylacea</i>	Rubiaceae	Endangered	Tree	1.408126	103.979065
<i>Suregada glomerulata</i>	Euphorbiaceae	Critically endangered	Tree	1.40878	103.975556
<i>Symplocos fasciculata</i>	Symplocaceae	Vulnerable	Tree	1.408653	103.976147
<i>Syzygium pycnanthum</i>	Myrtaceae	Critically endangered	Tree	1.409485	103.977346
<i>Syzygium pycnanthum</i>	Myrtaceae	Critically endangered	Tree	1.408543	103.975578
<i>Syzygium pycnanthum</i>	Myrtaceae	Critically endangered	Tree	1.408781	103.977197
<i>Syzygium pycnanthum</i>	Myrtaceae	Critically endangered	Tree	1.409622	103.977909
<i>Syzygium pycnanthum</i>	Myrtaceae	Critically endangered	Tree	1.409448	103.977806
<i>Syzygium pycnanthum</i>	Myrtaceae	Critically endangered	Tree	1.409093	103.977611
<i>Syzygium pycnanthum</i>	Myrtaceae	Critically endangered	Tree	1.409134	103.977393
<i>Syzygium pycnanthum</i>	Myrtaceae	Critically endangered	Tree	1.410021	103.977556
<i>Syzygium syzygioides</i>	Myrtaceae	Vulnerable	Tree	1.408636	103.977051
<i>Tarenna fragrans</i>	Rubiaceae	Endangered	Shrub	1.410857	103.979305
<i>Trema tomentosa</i>	Cannabaceae	Vulnerable	Shrub	1.408343	103.97609
<i>Tristellateia australasiae</i>	Malpighiaceae	Endangered	Climber	1.408286	103.978471

Pulau Ubin Durian Appendix C - Locations of Plants of Conservation Significance

<i>Utania nervosa</i>	Gentianaceae	Vulnerable	Tree	1.408884	103.976742
<i>Utania nervosa</i>	Gentianaceae	Vulnerable	Tree	1.408845	103.97673
<i>Utania nervosa</i>	Gentianaceae	Vulnerable	Tree	1.40858	103.976402
<i>Utania nervosa</i>	Gentianaceae	Vulnerable	Tree	1.408578	103.976372
<i>Utania nervosa</i>	Gentianaceae	Vulnerable	Tree	1.408688	103.976218
<i>Utania nervosa</i>	Gentianaceae	Vulnerable	Tree	1.408639	103.976154
<i>Utania nervosa</i>	Gentianaceae	Vulnerable	Tree	1.408594	103.976033
<i>Utania nervosa</i>	Gentianaceae	Vulnerable	Tree	1.408686	103.975977
<i>Utania nervosa</i>	Gentianaceae	Vulnerable	Tree	1.408655	103.975861
<i>Utania nervosa</i>	Gentianaceae	Vulnerable	Tree	1.408653	103.975777
<i>Utania nervosa</i>	Gentianaceae	Vulnerable	Tree	1.40871	103.975716
<i>Utania nervosa</i>	Gentianaceae	Vulnerable	Tree	1.408745	103.975796
<i>Utania nervosa</i>	Gentianaceae	Vulnerable	Tree	1.40871	103.975519
<i>Utania nervosa</i>	Gentianaceae	Vulnerable	Tree	1.408627	103.975469
<i>Utania nervosa</i>	Gentianaceae	Vulnerable	Tree	1.408338	103.975562
<i>Utania nervosa</i>	Gentianaceae	Vulnerable	Tree	1.408287	103.975574
<i>Utania nervosa</i>	Gentianaceae	Vulnerable	Tree	1.40878	103.975556
<i>Utania nervosa</i>	Gentianaceae	Vulnerable	Tree	1.40907	103.975889
<i>Utania nervosa</i>	Gentianaceae	Vulnerable	Tree	1.409109	103.975938
<i>Utania nervosa</i>	Gentianaceae	Vulnerable	Tree	1.408846	103.976351
<i>Utania nervosa</i>	Gentianaceae	Vulnerable	Tree	1.408792	103.976214
<i>Utania nervosa</i>	Gentianaceae	Vulnerable	Tree	1.408785	103.976069
<i>Utania nervosa</i>	Gentianaceae	Vulnerable	Tree	1.408928	103.976834
<i>Utania nervosa</i>	Gentianaceae	Vulnerable	Tree	1.408865	103.976923
<i>Utania nervosa</i>	Gentianaceae	Vulnerable	Tree	1.408809	103.97687
<i>Utania nervosa</i>	Gentianaceae	Vulnerable	Tree	1.408681	103.976945
<i>Utania nervosa</i>	Gentianaceae	Vulnerable	Tree	1.4088	103.977138
<i>Utania nervosa</i>	Gentianaceae	Vulnerable	Tree	1.410188	103.979262
<i>Utania nervosa</i>	Gentianaceae	Vulnerable	Tree	1.410109	103.979179
<i>Utania nervosa</i>	Gentianaceae	Vulnerable	Tree	1.410037	103.979224
<i>Utania nervosa</i>	Gentianaceae	Vulnerable	Tree	1.40938	103.979319
<i>Utania nervosa</i>	Gentianaceae	Vulnerable	Tree	1.409049	103.979276
<i>Utania nervosa</i>	Gentianaceae	Vulnerable	Tree	1.408664	103.979441
<i>Utania nervosa</i>	Gentianaceae	Vulnerable	Tree	1.410783	103.978136
<i>Utania nervosa</i>	Gentianaceae	Vulnerable	Tree	1.410805	103.97812
<i>Utania nervosa</i>	Gentianaceae	Vulnerable	Tree	1.410548	103.979344
<i>Utania nervosa</i>	Gentianaceae	Vulnerable	Tree	1.410707	103.979368
<i>Utania nervosa</i>	Gentianaceae	Vulnerable	Tree	1.410631	103.979282
<i>Utania nervosa</i>	Gentianaceae	Vulnerable	Tree	1.41063	103.978234
<i>Utania nervosa</i>	Gentianaceae	Vulnerable	Tree	1.410479	103.978219
<i>Utania nervosa</i>	Gentianaceae	Vulnerable	Tree	1.410316	103.978249
<i>Utania nervosa</i>	Gentianaceae	Vulnerable	Tree	1.410267	103.978235
<i>Utania nervosa</i>	Gentianaceae	Vulnerable	Tree	1.41011	103.978154
<i>Utania nervosa</i>	Gentianaceae	Vulnerable	Tree	1.410137	103.978134
<i>Utania nervosa</i>	Gentianaceae	Vulnerable	Tree	1.410373	103.978008
<i>Utania nervosa</i>	Gentianaceae	Vulnerable	Tree	1.409868	103.978085
<i>Utania nervosa</i>	Gentianaceae	Vulnerable	Tree	1.409653	103.977988
<i>Utania nervosa</i>	Gentianaceae	Vulnerable	Tree	1.409641	103.977924
<i>Utania nervosa</i>	Gentianaceae	Vulnerable	Tree	1.409452	103.977862
<i>Utania nervosa</i>	Gentianaceae	Vulnerable	Tree	1.409166	103.977515
<i>Utania nervosa</i>	Gentianaceae	Vulnerable	Tree	1.409021	103.977307
<i>Utania nervosa</i>	Gentianaceae	Vulnerable	Tree	1.409156	103.977068

Pulau Ubin Durian Appendix C - Locations of Plants of Conservation Significance

<i>Utania nervosa</i>	Gentianaceae	Vulnerable	Tree	1.409347	103.977301
<i>Utania nervosa</i>	Gentianaceae	Vulnerable	Tree	1.409539	103.977418
<i>Utania nervosa</i>	Gentianaceae	Vulnerable	Tree	1.409571	103.977503
<i>Utania nervosa</i>	Gentianaceae	Vulnerable	Tree	1.4098	103.977428
<i>Utania nervosa</i>	Gentianaceae	Vulnerable	Tree	1.409828	103.977461
<i>Utania nervosa</i>	Gentianaceae	Vulnerable	Tree	1.409787	103.977526
<i>Utania nervosa</i>	Gentianaceae	Vulnerable	Tree	1.410115	103.977602
<i>Utania nervosa</i>	Gentianaceae	Vulnerable	Tree	1.410453	103.977906
<i>Utania nervosa</i>	Gentianaceae	Vulnerable	Tree	1.410653	103.977849
<i>Utania nervosa</i>	Gentianaceae	Vulnerable	Tree	1.410729	103.977768

Appendix D
Locations and Size Data of
Significant Large Trees

Species	National Conservation Status	Girth (m)	Ht (m)	Latitude	Longitude
<i>Casuarina equisetifolia</i>	Common	3	25	1.41011	103.978154
<i>Cyrtophyllum fragrans</i>	Common	3.7	20	1.41031	103.977611
<i>Ficus caulocarpa</i>	Endangered	3	25	1.408676	103.975348
<i>Ficus microcarpa</i>	Common	7	15	1.410864	103.978366

Appendix E
List of Recorded Faunal
Species and Probable
Species

Species Summary Table

Faunal group	No. of probable CS species	No. of recorded species		No. of unrecorded but probable CS species
		All species	CS species	
Butterflies	26	29	3	23
Odonates	2	16	1	1
Amphibians	0	4	0	0
Reptiles	9	7	1	8
Birds	33	58	7	26
Mammals (Non-volant)	7	8	4	3
Mammals (Bats)	9	6	0	9
Fishes	5	23	0	
Decapod crustaceans	18	26	1	
Molluscs	18	107	1	
Xiphosurid	2	1	1	
Others	11	10	0	
Total		295	19	

No.	Type	Family	Scientific Name	Common Name	Global Status (IUCN/CITES)	National Status	Distribution/Rarity	Recorded species	Expected species
1	Bird	Accipitridae	<i>Nisaetus cirrhatus</i>	Changeable hawk-eagle	Least Concern; CITES protected (Appendix II)	Endangered	Uncommon	Yes	Yes
2	Bird	Alcedinidae	<i>Alcedo atthis</i>	Common kingfisher	Least Concern	Vulnerable	Common	Yes	Yes
3	Bird	Ardeidae	<i>Ardea cinerea</i>	Grey heron	Least Concern	Vulnerable	Uncommon	Yes	Yes
4	Bird	Ardeidae	<i>Ardea sumatrana</i>	Great-billed heron	Least Concern	Critically Endangered	Uncommon	Yes	Yes
5	Bird	Muscicapidae	<i>Copsychus malabaricus</i>	White-rumped shama	Least Concern	Critically Endangered	Uncommon	Yes	Yes
6	Bird	Muscicapidae	<i>Copsychus saularis</i>	Oriental magpie-robin	Least Concern	Endangered	Uncommon	Yes	Yes
7	Bird	Nectariniidae	<i>Leptocoma calcostetha</i>	Copper-throated sunbird	Least Concern	Vulnerable	Uncommon	Yes	Yes
8	Bird	Pycnonotidae	<i>Pycnonotus zeylanicus</i>	Straw-headed bulbul	Critically Endangered; CITES protected (Appendix II)	Endangered	Uncommon	Yes	Yes
9	Bird	Scolopacidae	<i>Actitis hypoleucos</i>	Common sandpiper	Least Concern	Vulnerable	Common	Yes	Yes
10	Butterfly	Nymphalidae (Brush Fooths)	<i>Euploea tulliolus ledereri</i>	Dwarf crow	Not Listed	Endangered	Moderately rare	Yes	Yes
11	Butterfly	Nymphalidae (Brush Fooths)	<i>Polyura moori moori</i>	Malayan nawab	Not Listed	Nationally Extinct (Rediscovered)	Very rare (seasonal migrant)	Yes	Yes
12	Damselfly	Coenagrionidae	<i>Mortonagrion arthuri</i>	Arthur's midget	Near Threatened	Vulnerable	Restricted and Rare	Yes	Yes
13	Decapod	Thalassinidae	NA	Mud mound lobster	Not Assessed	Endangered	NA	Yes*	Yes
14	Mammal	Cercopithecidae	<i>Macaca fascicularis</i>	Long-tailed macaque	Vulnerable; CITES protected (Appendix II)	Least Concern	Widespread and Common	Yes	Yes
15	Mammal	Felidae	<i>Prionailurus bengalensis</i>	Leopard cat	Least Concern; CITES protected (Appendix I)	Critically Endangered	Restricted and Rare	Yes	Yes
16	Mammal	Mustelidae	<i>Lutrogale perspicillata</i>	Smooth otter	Vulnerable; CITES protected (Appendix I)	Endangered	Widespread but Rare	Yes	Yes
17	Mammal	Tragulidae	<i>Tragulus napu</i>	Greater mousedeer	Least Concern	Critically Endangered	Restricted and Rare	Yes	Yes
18	Mollusc	Neritidae	<i>Clithon oualaniense</i>	NA	Least Concern	Vulnerable	NA	Yes	Yes
19	Reptile	Typhlopidae	<i>Argyrophis muelleri</i>	White-bellied blind snake	Least Concern	Critically Endangered	Widespread but Rare	Yes	Yes
20	Xiphosurid	Limulidae	<i>Carcinoscorpius rotundicauda</i>	NA	Data Deficient	Vulnerable	NA	Yes	Yes

*Mud mounds were recorded only.

Odonates

No.	Type	Family	Scientific Name	Common Name	Global Status (IUCN/CITES)	National Status (Soh & Ngiam, 2019)	Species of Conservation Significance	Distribution/Rarity (Soh et al. 2019)	Recorded Species	Probable Species
1	Damselfly	Coenagrionidae	<i>Agriocnemis rubescens</i>	Variable sprite	Least Concern	Least Concern	No	Widespread but Uncommon	Yes	Yes
2	Damselfly	Coenagrionidae	<i>Mortonagrion arthuri</i>	Arthur's midget	Near Threatened	Vulnerable	Yes	Restricted and Rare	Yes	Yes
3	Dragonfly	Aeshnidae	<i>Anax panybeus</i>	Arrow emperor	Least Concern	Least Concern	No	Widespread but Rare	No	Yes
4	Dragonfly	Libellulidae	<i>Agrioptera insignis</i>	Grenadier	Least Concern	Least Concern	No	Widespread and Common	Yes	Yes
5	Dragonfly	Libellulidae	<i>Brachydiplax chalybea</i>	Blue dasher	Least Concern	Least Concern	No	Widespread and Common	Yes	Yes
6	Dragonfly	Libellulidae	<i>Camacina gigantea</i>	Sultan	Least Concern	Least Concern	No	Widespread but Uncommon	Yes	Yes
7	Dragonfly	Libellulidae	<i>Cratilla lineata</i>	Lined forest skimmer	Least Concern	Near Threatened	No	Widespread but Uncommon	Yes	Yes
8	Dragonfly	Libellulidae	<i>Cratilla metallica</i>	Dark-tipped forest skimmer	Least Concern	Least Concern	No	Widespread and Common	Yes	Yes
9	Dragonfly	Libellulidae	<i>Macrodiplax cora</i>	Coastal glider	Least Concern	Least Concern	No	Widespread and Common	Yes	Yes
10	Dragonfly	Libellulidae	<i>Orthetrum chrysis</i>	Spine-tufted skimmer	Least Concern	Least Concern	No	Widespread and Common	Yes	Yes
11	Dragonfly	Libellulidae	<i>Orthetrum sabina</i>	Variogated green skimmer	Least Concern	Least Concern	No	Widespread and Common	Yes	Yes
12	Dragonfly	Libellulidae	<i>Pantala flavescens</i>	Wandering glider	Least Concern	Least Concern	No	Widespread and Common	Yes	Yes
13	Dragonfly	Libellulidae	<i>Pornothemis starrei</i>	Mangrove marshal	Not Listed	Near Threatened	No	Widespread but Uncommon	Yes	Yes
14	Dragonfly	Libellulidae	<i>Raphismia bispina</i>	Mangrove dwarf	Least Concern	Near Threatened	No	Widespread but Uncommon	Yes	Yes
15	Dragonfly	Libellulidae	<i>Rhyothemis phyllis</i>	Yellow-barred flutterer	Least Concern	Least Concern	No	Widespread and Common	Yes	Yes
16	Dragonfly	Libellulidae	<i>Tramea transmarina</i>	Saddlebag glider	Least Concern	Least Concern	No	Widespread and Common	Yes	Yes
17	Dragonfly	Macromiidae	<i>Epophthalmia vittigera</i>	Pond cruiser	Least Concern	Least Concern	No	Widespread and Common	Yes	Yes

Butterflies

No.	Family	Scientific Name	Common Name	Global Status (IUCN/CITES)	National Status (Davison et al., 2008; Jain et al, 2018)	Species of Conservation Significance	Distribution/ Abundance /Rarity (Khew, 2015)	Recorded Species	Probable Species
1	Hesperiidae	<i>Astictopterus jama jama</i>	Forest hopper	Not Listed	Nationally Extinct (Rediscovered)	Yes	Moderately rare	No	Yes
2	Hesperiidae	<i>Borbo cinnara</i>	Formosan swift	Not Listed	Endangered	Yes	Moderately common	No	Yes
3	Hesperiidae	<i>Caltonis malaya</i>	Malayan swift	Not Listed	Nationally Extinct (Rediscovered)	Yes	Moderately rare	No	Yes
4	Hesperiidae	<i>Celaenorrhinus asmara asmara</i>	White banded flat	Not Listed	Nationally Extinct (Rediscovered)	Yes	Very rare	No	Yes
5	Hesperiidae	<i>Cephrenes acalle niasicus</i>	Plain palm dart	Not Listed	Nationally Extinct (Rediscovered)	Yes	Moderately rare	No	Yes
6	Hesperiidae	<i>Hasora chromus chromus</i>	Common banded awl	Not Listed	Not Evaluated	No	Moderately rare	Yes	Yes
7	Hesperiidae	<i>Pelopidas agna agna</i>	Bengal swift	Not Listed	Endangered	Yes	Moderately common	No	Yes
8	Hesperiidae	<i>Potanthus trachala tyleri</i>	Detached dart	Not Listed	Nationally Extinct (Rediscovered)	Yes	Moderately rare	No	Yes
9	Hesperiidae	<i>Suastrus everyx everyx</i>	White palm bob	Not Listed	Endangered	Yes	Rare	No	Yes
10	Hesperiidae	<i>Telicota colon stinga</i>	Common palm dart	Not Listed	Nationally Extinct (Rediscovered)	Yes	Moderately common	No	Yes
11	Lycaenidae	<i>Arhopala amphimuta amphimuta</i>	NA	Not Listed	Nationally Extinct (Rediscovered)	Yes	Moderately common	No	Yes
12	Lycaenidae	<i>Catopyrops ancya</i>	Ancya blue	Not Listed	Vulnerable	Yes	Moderately rare	No	Yes
13	Lycaenidae	<i>Curetis saronis sumatrana</i>	Sumatran sunbeam	Not Listed	Not Evaluated	No	Moderately common	Yes	Yes
14	Lycaenidae	<i>Jamides alecto ageladas</i>	Metallic caerulean	Not Listed	Nationally Extinct (Rediscovered)	Yes	Moderately rare	No	Yes
15	Lycaenidae	<i>Logania marmorata damis</i>	Pale mottle	Not Listed	Not Evaluated	No	Moderately common	Yes	Yes
16	Lycaenidae	<i>Miletus sp.</i>	NA	NA	NA	NA	NA	Yes	Yes
17	Lycaenidae	<i>Nacaduba kurava nemana</i>	Transparent sixline blue	Not Listed	Nationally Extinct (Rediscovered)	Yes	Moderately common	No	Yes
18	Lycaenidae	<i>Nacaduba pactolus odon</i>	Large fourline blue	Not Listed	Nationally Extinct (Rediscovered)	Yes	Moderately rare	No	Yes
19	Lycaenidae	<i>Rachana jalindra burbona</i>	Banded royal	Not Listed	Critically Endangered	Yes	Very rare	No	Yes
20	Lycaenidae	<i>Spalgis epius epius</i>	Apely	Not Listed	Not Evaluated	No	Moderately common	Yes	Yes
21	Nymphalidae (Brush Fooths)	<i>Amathusia phidippus phidippus</i>	Palm king	Not Listed	Not Evaluated	No	Moderately rare	Yes	Yes
22	Nymphalidae (Brush Fooths)	<i>Ariadne ariadne ariadne</i>	Angled castor	Not Listed	Nationally Extinct (Rediscovered)	Yes	Very rare	No	Yes
23	Nymphalidae (Brush Fooths)	<i>Athyrna nefte subrata</i>	Colour sergeant	Not Listed	Not Evaluated	No	Common	Yes	Yes
24	Nymphalidae (Brush Fooths)	<i>Cethosia methypsea</i>	Plain lacewing	Not Listed	Critically Endangered	Yes	Very rare	No	Yes
25	Nymphalidae (Brush Fooths)	<i>Discophora sondaica despoliata</i>	Common duffer	Not Listed	Critically Endangered	Yes	Rare	No	Yes
26	Nymphalidae (Brush Fooths)	<i>Elymnias hypermnestra agina</i>	Common palmfly	Not Listed	Not Evaluated	No	Common	Yes	Yes
27	Nymphalidae (Brush Fooths)	<i>Euploea mulciber mulciber</i>	Striped blue crow	Not Listed	Not Evaluated	No	Common	Yes	Yes
28	Nymphalidae (Brush Fooths)	<i>Euploea tulliolus ledereri</i>	Dwarf crow	Not Listed	Endangered	Yes	Moderately rare	Yes	Yes
29	Nymphalidae (Brush Fooths)	<i>Idea leuconoe chersonesia</i>	Mangrove tree nymph	Not Listed	Critically Endangered	Yes	Very rare	No	Yes
30	Nymphalidae (Brush Fooths)	<i>Ideopsis vulgaris macrina</i>	Blue glassy tiger	Not Listed	Not Evaluated	No	Common	Yes	Yes
31	Nymphalidae (Brush Fooths)	<i>Junonia almana javana</i>	Peacock pansy	Least Concern	Not Evaluated	No	Common	Yes	Yes
32	Nymphalidae (Brush Fooths)	<i>Junonia hedonia ida</i>	Chocolate pansy	Not Listed	Not Evaluated	No	Common	Yes	Yes
33	Nymphalidae (Brush Fooths)	<i>Lebadea martha</i>	Knight	NA	NA	NA	NA	Yes	Yes
34	Nymphalidae (Brush Fooths)	<i>Lebadea martha malayana</i>	Knight	Not Listed	Not Evaluated	No	Rare	Yes	Yes
35	Nymphalidae (Brush Fooths)	<i>Mycalesis perseoides perseoides</i>	Burmese bush brown	Not Listed	Data Deficient	No	Common	Yes	Yes
36	Nymphalidae (Brush Fooths)	<i>Neptis sp.</i>	NA	NA	NA	NA	NA	Yes	Yes
37	Nymphalidae (Brush Fooths)	<i>Pantoporia paraka paraka</i>	Perak lascar	Not Listed	Not Evaluated	No	Moderately common	Yes	Yes
38	Nymphalidae (Brush Fooths)	<i>Parantica agleoides agleoides</i>	Dark glassy tiger	Not Listed	Not Evaluated	No	Common	Yes	Yes
39	Nymphalidae (Brush Fooths)	<i>Parantica aspasia aspasia</i>	Yellow glassy tiger	Not Listed	Nationally Extinct (Rediscovered)	Yes	Very rare (seasonal migrant)	No	Yes

Butterflies

No.	Family	Scientific Name	Common Name	Global Status (IUCN/CITES)	National Status (Davison et al., 2008; Jain et al, 2018)	Species of Conservation Significance	Distribution/ Abundance /Rarity (Khew, 2015)	Recorded Species	Probable Species
40	Nymphalidae (Brush Fooths)	<i>Phaedyra columella singa</i>	Short banded sailor	Not Listed	Not Evaluated	No	Common	Yes	Yes
41	Nymphalidae (Brush Fooths)	<i>Phalanta phalantha phalantha</i>	Leopard	Not Listed	Not Evaluated	No	Common	Yes	Yes
42	Nymphalidae (Brush Fooths)	<i>Polyura moori moori</i>	Malayan nawab	Not Listed	Nationally Extinct (Rediscovered)	Yes	Very rare (seasonal migrant)	Yes	Yes
43	Nymphalidae (Brush Fooths)	<i>Polyura schreiber tisamenus</i>	Blue nawab	Not Listed	Not Evaluated	No	Moderately rare	Yes	Yes
44	Nymphalidae (Brush Fooths)	<i>Ypthima baldus newboldi</i>	Common five-ring	Not Listed	Not Evaluated	No	Common	Yes	Yes
45	Papilionidae (Swallowtails & Birdwings)	<i>Graphium doson evemonides</i>	Common jay	Not Listed	Not Evaluated	No	Moderately rare	Yes	Yes
46	Papilionidae (Swallowtails & Birdwings)	<i>Pachliopta aristolochiae asteris</i>	Common rose	Not Listed	Vulnerable	Yes	Moderately common	No	Yes
47	Papilionidae (Swallowtails & Birdwings)	<i>Papilio polytes romulus</i>	Common mormon	Not Listed	Not Evaluated	No	Common	Yes	Yes
48	Papilionidae (Swallowtails & Birdwings)	<i>Troides helena cerberus</i>	Common birdwing	Not Listed	Vulnerable	Yes	Moderately common	No	Yes
49	Pieridae (Whites & Sulphurs)	<i>Cepora iudith malaya</i>	Orange gull	Not Listed	Not Evaluated	No	Very rare	Yes	Yes
50	Pieridae (Whites & Sulphurs)	<i>Delias hyparete metarete</i>	Painted jezebel	Not Listed	Not Evaluated	No	Common	Yes	Yes
51	Pieridae (Whites & Sulphurs)	<i>Eurema blanda snelleni</i>	Three spot grass yellow	Not Listed	Not Evaluated	No	Common	Yes	Yes
52	Pieridae (Whites & Sulphurs)	<i>Pareronia valeria lutescens</i>	Wanderer	Not Listed	Nationally Extinct (Rediscovered)	Yes	Very rare	No	Yes

Amphibians

No.	Type	Family	Scientific Name	Common Name	Global Status (IUCN/CITES)	National Status (NParks, 2021)	Species of Conservation Significance	Distribution/ Abundance/ Rarity (Baker & Lim, 2012)	Native Status (Baker & Lim, 2012)	Recorded Species
1	Frog	Dicoglossidae	<i>Fejervarya cancrivora</i>	Crab-eating frog	Least Concern	Least Concern	No	Widespread and Common	Native	Yes
2	Frog	Microhylidae	<i>Microhyla heymonsi</i>	Dark-sided chorus frog	Least Concern	Least Concern	No	Widespread and Common	Native	Yes
3	Frog	Rhacophoridae	<i>Polypedates leucomystax</i>	Four-lined tree frog	Least Concern	Least Concern	No	Widespread and Common	Native	Yes
4	Toad	Bufoidea	<i>Duttaphrynus bengalensis</i>	Asian toad	Least Concern	NA	No	Widespread and Common	Native	Yes

Reptiles

No.	Type	Family	Scientific Name	Common Name	Global Status (IUCN/CITES)	National Status (NParks, 2021)	Species of Conservation Significance	Distribution/ Abundance/ Rarity (Baker & Lim, 2012)	Native Status (Baker & Lim, 2012)	Recorded species	Probable Species
1	Marine snake	Elapidae	<i>Aipysurus eydouxi</i>	Beaded sea-snake	Least Concern	Endangered	Yes	NA	NA	No	Yes
2	Non-marine lizard	Agamidae	<i>Bronchocelea cristatella</i>	Green crested lizard	Not Listed	Least Concern	No	Widespread but Uncommon	Native	Yes	Yes
3	Non-marine lizard	Scincidae	<i>Eutropis multifasciata</i>	Many-lined sun skink	Not Listed	Least Concern	No	Widespread and Common	Native	Yes	Yes
4	Non-marine lizard	Varanidae	<i>Varanus salvator</i>	Malayan water monitor	Least Concern	Least Concern	No	Widespread and Common	Native	Yes	Yes
5	Non-marine snake	Colubridae (Ahaetullinae)	<i>Ahaetulla prasina</i>	Oriental whip snake	Least Concern	Least Concern	No	Widespread and Common	Native	Yes	Yes
6	Non-marine snake	Colubridae (Ahaetullinae)	<i>Dendrelaphis caudolineatus</i>	Striped bronzeback	Least Concern	Least Concern	No	Widespread and Common	Native	Yes	Yes
7	Non-marine snake	Colubridae (Ahaetullinae)	<i>Dryophiops rubescens</i>	Keel-bellied whip snake	Least Concern	Endangered	Yes	Restricted and Rare	Native	No	Yes
8	Non-marine snake	Colubridae (Colubrinae)	<i>Boiga cynodon</i>	Dog-toothed cat snake	Least Concern	Vulnerable	Yes	Restricted and Rare	Native	No	Yes
9	Non-marine snake	Colubridae (Colubrinae)	<i>Boiga melanota</i>	Gold-ringed cat snake	Least Concern	Vulnerable	Yes	Widespread but Rare	Native	No	Yes
10	Non-marine snake	Colubridae (Sibynophiinae)	<i>Sibynophis melanocephalus</i>	Black-headed collared snake	Least Concern	Vulnerable	Yes	Widespread but Uncommon	Native	No	Yes
11	Non-marine snake	Elapidae	<i>Bungarus fasciatus</i>	Banded krait	Least Concern	Endangered	Yes	Restricted and Rare	Native	No	Yes
12	Non-marine snake	Typhlopidae	<i>Argyrophis muelleri</i>	White-bellied blind snake	Least Concern	Critically Endangered	Yes	Widespread but Rare	Native	Yes	Yes
13	Non-marine snake	Typhlopidae	<i>Indotyphlops braminus</i>	Brahminy blind snake	Least Concern	Not Evaluated	No	Widespread and Common	Native	Yes	Yes
14	Non-marine snake	Viperidae	<i>Trimeresurus purpureomaculatus</i>	Shore pit viper	Least Concern	Vulnerable	Yes	Restricted and Rare	Native	No	Yes
15	Non-marine turtle	Geomydidae	<i>Cuora amboinensis</i>	Malayan box terrapin	Endangered	Near Threatened	Yes	Restricted but Common	Native	No	Yes

No.	Family	Scientific Name	Common Name	Global Status (IUCN/CITES)	National Status (Davison et al., 2008)	Species of Conservation Significance	Distribution/ Abundance/ Rarity (NSS, 2020; Singapore Birds Project, 2020)	Primary Native Status (NSS, 2020; Singapore Birds Project, 2020)	Recorded Species	Probable Species
1	Accipitridae	<i>Accipiter trivirgatus</i>	Crested goshawk	Least Concern	Near Threatened	No	Uncommon	Resident breeder	No	Yes
2	Accipitridae	<i>Aviceda leuphotes</i>	Black baza	Least Concern	Least Concern	No	Common	Passage migrant	Yes	Yes
3	Accipitridae	<i>Haliaeetus ichthyetus</i>	Grey-headed fish eagle	Near Threatened	Vulnerable	Yes	Uncommon	Resident breeder	No	Yes
4	Accipitridae	<i>Haliaeetus leucogaster</i>	White-bellied sea eagle	Least Concern	Least Concern	No	Common	Resident breeder	Yes	Yes
5	Accipitridae	<i>Haliastur indus</i>	Brahminy kite	Least Concern	Least Concern	No	Common	Resident breeder	Yes	Yes
6	Accipitridae	<i>Nisetus cirrhatus</i>	Changeable hawk-eagle	Least Concern	Vulnerable	Yes	Common	Resident breeder	Yes	Yes
7	Accipitridae	<i>Pernis ptilorhynchus</i>	Crested honey-buzzard	Least Concern	Least Concern	No	Common	Passage migrant	Yes	Yes
8	Accipitridae	<i>Spilornis cheela</i>	Crested serpent eagle	Least Concern	Critically Endangered	Yes	Rare	Resident, breeding not proven	No	Yes
9	Aegithinidae	<i>Aegithina tiphia</i>	Common lora	Least Concern	Least Concern	No	Common	Resident breeder	Yes	Yes
10	Alcedinidae	<i>Alcedo althia</i>	Common kingfisher	Least Concern	Vulnerable	Yes	Common	Winter visitor	Yes	Yes
11	Alcedinidae	<i>Alcedo meninting</i>	Blue-eared kingfisher	Least Concern	Endangered	Yes	Uncommon	Resident breeder	No	Yes
12	Alcedinidae	<i>Halyon coromanda</i>	Ruddy kingfisher	Least Concern	Critically Endangered	Yes	Uncommon	Resident breeder	No	Yes
13	Alcedinidae	<i>Halyon pileata</i>	Black-capped kingfisher	Least Concern	Vulnerable	Yes	Uncommon	Winter visitor	Yes	Yes
14	Alcedinidae	<i>Ptilinopus capensis</i>	Stork-billed kingfisher	Least Concern	Least Concern	No	Uncommon	Resident breeder	Yes	Yes
15	Alcedinidae	<i>Todiramphus chloris</i>	Collared kingfisher	Least Concern	Least Concern	No	Abundant	Resident breeder	Yes	Yes
16	Apodidae	<i>Aerodramus sp.</i>	Swiftlet	NA	NA	NA	NA	NA	Yes	Yes
17	Ardeidae	<i>Ardea cinerea</i>	Grey heron	Least Concern	Least Concern	No	Common	Resident breeder	Yes	Yes
18	Ardeidae	<i>Ardea purpurea</i>	Purple heron	Least Concern	Endangered	Yes	Uncommon	Resident breeder	No	Yes
19	Ardeidae	<i>Ardea sumatrana</i>	Great-billed heron	Least Concern	Critically Endangered	Yes	Uncommon	Resident breeder	Yes	Yes
20	Ardeidae	<i>Egretta eulophotes</i>	Chinese egret	Vulnerable	Endangered	Yes	Rare	Winter visitor	No	Yes
21	Ardeidae	<i>Nycticorax nycticorax</i>	Black-crowned night heron	Least Concern	Endangered	Yes	Uncommon	Resident breeder	No	Yes
22	Bucerotidae	<i>Anthracoceros albirostris</i>	Oriental pied hornbill	Least Concern	Near Threatened	No	Common	Introduced resident breeder	Yes	Yes
23	Campophagidae	<i>Lalage nigra</i>	Pied triller	Least Concern	Least Concern	No	Common	Resident breeder	Yes	Yes
24	Caprimulgidae	<i>Caprimulgus macrurus</i>	Large-tailed nightjar	Least Concern	Least Concern	No	Common	Resident breeder	Yes	Yes
25	Charadriidae	<i>Charadrius persill</i>	Malaysian plover	Near Threatened	Critically Endangered	Yes	Uncommon	Resident breeder	No	Yes
26	Ciconiidae	<i>Leptoptilos javanicus</i>	Lesser adjutant	Vulnerable	Vulnerable	Yes	Rare	Non-breeding visitor	No	Yes
27	Cisticolidae	<i>Orthotomus atrocapillus</i>	Dark-necked tailorbird	Least Concern	Least Concern	No	Common	Resident breeder	Yes	Yes
28	Cisticolidae	<i>Orthotomus ruficeps</i>	Ashy tailorbird	Least Concern	Least Concern	No	Common	Resident breeder	Yes	Yes
29	Cisticolidae	<i>Orthotomus sericeus</i>	Rufous-tailed tailorbird	Least Concern	Near Threatened	No	Uncommon	Resident breeder	Yes	Yes
30	Cisticolidae	<i>Orthotomus sutorius</i>	Common tailorbird	Least Concern	Least Concern	No	Common	Resident breeder	Yes	Yes
31	Columbidae	<i>Treron vernans</i>	Pink-necked green pigeon	Least Concern	Least Concern	No	Abundant	Resident breeder	Yes	Yes
32	Corvidae	<i>Corvus splendens</i>	House crow	Least Concern	NA	No	Common	Introduced resident breeder	Yes	Yes
33	Cuculidae	<i>Cacomantis merulinus</i>	Plainive cuckoo	Least Concern	Least Concern	No	Uncommon	Resident breeder	Yes	Yes
34	Cuculidae	<i>Cacomantis sepulchralis</i>	Rusty-breasted cuckoo	Least Concern	Near Threatened	No	Uncommon	Resident breeder	No	Yes
35	Cuculidae	<i>Centropus sp.</i>	Coucal	NA	NA	NA	NA	NA	Yes	Yes
36	Cuculidae	<i>Chrysococcyx xanthorhynchus</i>	Violet cuckoo	Least Concern	Vulnerable	Yes	Uncommon	Resident breeder	No	Yes
37	Dicaeidae	<i>Dicaeum cruentatum</i>	Scarlet-backed flowerpecker	Least Concern	Least Concern	No	Common	Resident breeder	Yes	Yes
38	Dicaeidae	<i>Dicaeum trigonostigma</i>	Orange-bellied flowerpecker	Least Concern	Near Threatened	No	Common	Resident breeder	Yes	Yes
39	Dicruridae	<i>Dicrurus annectans</i>	Crow-billed drongo	Least Concern	Near Threatened	No	Uncommon	Winter visitor	Yes	Yes
40	Dicruridae	<i>Dicrurus paradiseus</i>	Greater racket-tailed drongo	Least Concern	Least Concern	No	Common	Resident breeder	Yes	Yes
41	Hirundinidae	<i>Hirundo tahitica</i>	Pacific swallow	Least Concern	Least Concern	No	Common	Resident breeder	Yes	Yes
42	Laridae	<i>Sterna sumatrana</i>	Black-naped tern	Least Concern	Endangered	Yes	Uncommon	Resident breeder	No	Yes
43	Laridae	<i>Sterna albilrons</i>	Little tern	Least Concern	Endangered	Yes	Common	Resident breeder	No	Yes
44	Meropidae	<i>Merops philippinus</i>	Blue-tailed bee-eater	Least Concern	Least Concern	No	Common	Winter visitor	Yes	Yes
45	Meropidae	<i>Merops viridis</i>	Blue-throated bee-eater	Least Concern	Least Concern	No	Common	Migrant breeder	Yes	Yes
46	Muscicapidae	<i>Copsychus malabaricus</i>	White-rumped shama	Least Concern	Endangered	Yes	Uncommon	Resident breeder	Yes	Yes
47	Muscicapidae	<i>Copsychus saularis</i>	Oriental magpie-robber	Least Concern	Vulnerable	Yes	Uncommon	Resident breeder	Yes	Yes
48	Muscicapidae	<i>Cyornis brunneatus</i>	Brown-chested jungle flycatcher	Vulnerable	Vulnerable	Yes	Uncommon	Winter visitor	No	Yes
49	Muscicapidae	<i>Cyornis rufigaster</i>	Mangrove blue flycatcher	Least Concern	Critically Endangered	Yes	Rare	Resident breeder	No	Yes
50	Muscicapidae	<i>Ficedula zanthopygia</i>	Yellow-rumped flycatcher	Least Concern	Least Concern	No	Uncommon	Passage migrant	Yes	Yes
51	Muscicapidae	<i>Muscicapa dauurica</i>	Asian brown flycatcher	Least Concern	Least Concern	No	Common	Winter visitor	Yes	Yes
52	Nectarinidae	<i>Aethopyga siparaja</i>	Crimson sunbird	Least Concern	Least Concern	No	Common	Resident breeder	Yes	Yes
53	Nectarinidae	<i>Anthreptes malacensis</i>	Brown-throated sunbird	Least Concern	Least Concern	No	Common	Resident breeder	Yes	Yes
54	Nectarinidae	<i>Cinnyris jugularis</i>	Olive-backed sunbird	Least Concern	Least Concern	No	Common	Resident breeder	Yes	Yes
55	Nectarinidae	<i>Leptocoma brasiliana</i>	Van Hasselt's sunbird	Least Concern	Least Concern	No	Common	Resident breeder	Yes	Yes
56	Nectarinidae	<i>Leptocoma calcostetha</i>	Copper-throated sunbird	Least Concern	Vulnerable	Yes	Uncommon	Resident breeder	Yes	Yes
57	Oriolidae	<i>Oriolus chinensis</i>	Black-naped oriole	Least Concern	Least Concern	No	Abundant	Resident breeder	Yes	Yes
58	Pelloniidae	<i>Malaccocincla abbotti</i>	Abbott's babbler	Least Concern	Least Concern	No	Uncommon	Resident breeder	Yes	Yes
59	Phasianidae	<i>Gallus gallus</i>	Red junglefowl	Least Concern	Near Threatened	No	Common	Resident breeder	No	Yes
60	Phylloscopidae	<i>Phylloscopus borealis</i>	Arctic warbler	Least Concern	Least Concern	No	Common	Winter visitor	Yes	Yes
61	Picidae	<i>Dinopium javanense</i>	Common flameback	Least Concern	Least Concern	No	Common	Resident breeder	Yes	Yes
62	Picidae	<i>Micropternis brachyurus</i>	Rufous woodpecker	Least Concern	Least Concern	No	Uncommon	Resident breeder	Yes	Yes
63	Picidae	<i>Picus vittatus</i>	Laced woodpecker	Least Concern	Least Concern	No	Common	Resident breeder	Yes	Yes
64	Picidae	<i>Yungipicus moluccensis</i>	Sunda pygmy woodpecker	Least Concern	Least Concern	No	Common	Resident breeder	Yes	Yes
65	Pittidae	<i>Pitta megarhyncha</i>	Mangrove pitta	Near Threatened	Critically Endangered	Yes	Uncommon	Resident breeder	No	Yes
66	Pittidae	<i>Pitta moluccensis</i>	Blue-winged pitta	Least Concern	Least Concern	No	Uncommon	Winter visitor	Yes	Yes
67	Psittaculidae	<i>Loriculus galgulus</i>	Blue-crowned hanging-parrot	Least Concern	Least Concern	No	Common	Resident breeder	No	Yes
68	Psittaculidae	<i>Psittacula longicauda</i>	Long-tailed parakeet	Vulnerable	Near Threatened	Yes	Common	Resident breeder	No	Yes
69	Pycnonotidae	<i>Pycnonotus goiavier</i>	Yellow-vented bulbul	Least Concern	Least Concern	No	Abundant	Resident breeder	Yes	Yes
70	Pycnonotidae	<i>Pycnonotus plumosus</i>	Olive-winged bulbul	Least Concern	Least Concern	No	Common	Resident breeder	Yes	Yes
71	Pycnonotidae	<i>Pycnonotus zeylanicus</i>	Straw-headed bulbul	Critically Endangered	Endangered	Yes	Uncommon	Resident breeder	Yes	Yes
72	Rallidae	<i>Rallina fasciata</i>	Red-legged crane	Least Concern	Near Threatened	No	Uncommon	Resident breeder	No	Yes

No.	Family	Scientific Name	Common Name	Global Status (IUCN/CITES)	National Status (Davison et al., 2008)	Species of Conservation Significance	Distribution/ Abundance/ Rarity (NSS, 2020; Singapore Birds Project, 2020)	Primary Native Status (NSS, 2020; Singapore Birds Project, 2020)	Recorded Species	Probable Species
73	Rhipiduridae	<i>Rhipidura javanica</i>	Malaysian pied fantail	Least Concern	Least Concern	No	Common	Resident breeder	Yes	Yes
74	Scolopacidae	<i>Actitis hypoleucos</i>	Common sandpiper	Least Concern	Vulnerable	Yes	Common	Winter visitor	Yes	Yes
75	Scolopacidae	<i>Calidris pygmaea</i>	Spoon-billed sandpiper	Critically Endangered	Critically Endangered	Yes	Rare	Winter visitor	No	Yes
76	Scolopacidae	<i>Calidris tenuirostris</i>	Great knot	Endangered	Endangered	Yes	Rare	Passage migrant	No	Yes
77	Scolopacidae	<i>Numenius madagascariensis</i>	Far eastern curlew	Endangered	Endangered	Yes	Rare	Passage migrant	No	Yes
78	Scolopacidae	<i>Numenius phaeopus</i>	Eurasian whimbrel	Least Concern	Near Threatened	No	Common	Winter visitor	Yes	Yes
79	Scolopacidae	<i>Tringa guttifer</i>	Nordmann's greenshank	Endangered	Endangered	Yes	Rare	Winter visitor	No	Yes
80	Strigidae	<i>Ketupa ketupu</i>	Buffy fish owl	Least Concern	Vulnerable	Yes	Uncommon	Resident breeder	No	Yes
81	Strigidae	<i>Otus lempiji</i>	Sunda scops owl	Least Concern	Least Concern	No	Common	Resident breeder	Yes	Yes
82	Sturnidae	<i>Acridotheres javanicus</i>	Javan myna	Vulnerable	NA	No	Abundant	Introduced resident breeder	Yes	Yes
83	Sturnidae	<i>Aplonis panayensis</i>	Asian glossy starling	Least Concern	Least Concern	No	Abundant	Resident breeder	Yes	Yes
84	Sulidae	<i>Sula sula</i>	Red-footed booby	Least Concern	Least Concern	No	Rare	Non-breeding visitor	Yes	Yes

Non-volant mammals

No.	Family	Scientific Name	Common Name	Global Status (IUCN/CITES)	National Status (NParks, 2021)	Species of Conservation Significance	Distribution/Abundance/Rarity (Baker & Lim, 2012)	Native Status (NParks, 2021)	Recorded Species	Probable Species
1	Cercopithecidae	<i>Macaca fascicularis</i>	Long-tailed macaque	Endangered	Least Concern	Yes	Widespread and Common	Native	Yes	Yes
2	Delphinidae	<i>Orcaella brevirostris</i>	Irrawaddy dolphin	Vulnerable	Critically Endangered	Yes	NA	Native	No	Yes
3	Delphinidae	<i>Sousa chinensis</i>	Indo-pacific humpbacked dolphin	Near Threatened	Critically Endangered	Yes	NA	Native	No	Yes
4	Delphinidae	<i>Tursiops aduncus</i>	Indo-pacific bottlenose dolphin	Data Deficient	Critically Endangered	Yes	NA	Native	No	Yes
5	Dugongidae	<i>Dugong dugon</i>	Dugong	Vulnerable	Critically Endangered	Yes	NA	Native	No	Yes
6	Felidae	<i>Felis catus</i>	Feral cat	Not Listed	Not Evaluated	No	NA	Non-native	Yes	Yes
7	Felidae	<i>Prionailurus bengalensis</i>	Leopard cat	Least Concern	Critically Endangered	Yes	Restricted and Rare	Native	Yes	Yes
8	Hystricidae	<i>Hystrix brachyura</i>	Malayan porcupine	Least Concern	Critically Endangered	Yes	Restricted and Rare	Native	No	Yes
9	Manidae	<i>Manis javanica</i>	Sunda pangolin	Critically Endangered	Critically Endangered	Yes	Widespread but Rare	Native	No	Yes
10	Mustelidae	<i>Aonyx cinereus</i>	Oriental small-clawed otter	Vulnerable	Critically Endangered	Yes	Restricted and Rare	Native	No	Yes
11	Mustelidae	<i>Lutrogale perspicillata</i>	Smooth otter	Vulnerable	Endangered	Yes	Widespread but Rare	Native	Yes	Yes
12	Phocoenidae	<i>Neophocaena phocaenoides</i>	Finless porpoise	Vulnerable	Critically Endangered	Yes	NA	Native	No	Yes
13	Sciuridae	<i>Callosciurus notatus</i>	Plantain squirrel	Least Concern	Not Evaluated	No	Widespread and Common	Native	Yes	Yes
14	Suidae	<i>Sus scrofa</i>	Eurasian wild boar	Least Concern	Least Concern	No	Widespread and Common	Native	Yes	Yes
15	Tragulidae	<i>Tragulus napu</i>	Greater mousedeer	Least Concern	Critically Endangered	Yes	Restricted and Rare	Native	Yes	Yes
16	Viverridae	<i>Paradoxurus musangus</i>	Sumatran palm civet	Least Concern	Least Concern	No	Widespread but Uncommon	Native	Yes	Yes

Bats

No.	Family	Scientific Name	Common Name	Global Status (IUCN/CITES)	National Status (NParks, 2021)	Species of Conservation Significance	Distribution/Abundance/Rarity (Baker & Lim, 2012)	Native Status (NParks, 2021)	Recorded Species	Probable Species
1	Emballonuridae	<i>Emballonura monticola</i>	Lesser sheath-tailed bat	Least Concern	Critically Endangered	Yes	Restricted and Rare	Native	No	Yes
2	Emballonuridae	<i>Saccolaimus saccolaimus</i>	Pouch tomb bat	Least Concern	Least Concern	No	Widespread and Common	Native	Yes	Yes
3	Emballonuridae	<i>Taphozous longimanus</i>	Long-winged tomb bat	Least Concern	Critically Endangered	Yes	NA	Native	No	Yes
4	Emballonuridae	<i>Taphozous melanopogon</i>	Black-bearded tomb bat	Least Concern	Least Concern	No	Widespread but Rare	Native	Yes	Yes
5	Hipposideridae	<i>Hipposideros cineraceus</i>	Ashy roundleaf bat	Least Concern	Critically Endangered	Yes	NA	NA	No	Yes
6	Megadermatidae	<i>Megaderma spasma</i>	Lesser false-vampire	Least Concern	Endangered	Yes	Restricted and Rare	Native	No	Yes
7	Pteropodidae	<i>Cynopterus brachyotis</i>	Lesser short-nosed fruit bat	Least Concern	Not Evaluated	No	Widespread and Common	Native	Yes	Yes
8	Pteropodidae	<i>Eonycteris spelaea</i>	Cave nectar bat	Least Concern	Vulnerable	Yes	Widespread but Uncommon	Native	No	Yes
9	Pteropodidae	<i>Macroglossus minimus</i>	Lesser long-tongued nectar bat	Least Concern	Vulnerable	Yes	Restricted and Rare	Native	No	Yes
10	Pteropodidae	<i>Pteropus vampyrus</i>	Large flying-fox	Near Threatened	Critically Endangered	Yes	NA	Visitor	No	Yes
11	Vespertilionidae	<i>Hypsugo macrotis</i>	Big-eared pipistrelle	Data Deficient	Critically Endangered	Yes	NA	Native	No	Yes
12	Vespertilionidae	<i>Myotis horsfieldii</i>	Horsfield's myotis	Least Concern	Least Concern	No	NA	Native	Yes	Yes
13	Vespertilionidae	<i>Myotis muricola</i>	Asian whiskered myotis	Least Concern	Least Concern	No	Widespread and Common	Native	Yes	Yes
14	Vespertilionidae	<i>Scotophilus kuhlii</i>	Lesser Asian house bat	Least Concern	Least Concern	No	Widespread and Common	Native	Yes	Yes
15	Vespertilionidae	<i>Tylonycteris malayana</i>	Greater bamboo bat	Least Concern	Vulnerable	Yes	Widespread and Common	Native	No	Yes

No.	Type	Family	Scientific Name	Common Name	Global Status (IUCN/CITES)	National Status (NParks, 2021)	Species of Conservation Significance	Native Status (NParks, 2021)	Recorded Species	Probable Species
1	Freshwater fish	Aplocheilidae (Rivulines)	<i>Aplocheilus armatus</i>	Whitespot	Endangered	Least Concern	Yes	Native	Native	Yes
2	Freshwater fish	Zenarchopteridae (Halfbeaks)	<i>Dermogenys collettei</i>	Sunda pygmy halfbeak	Least Concern	Not Assessed	No	Native	Yes	Yes
3	Marine fish	Adrianchthyidae	<i>Oryzias javanicus</i>	Javanese ricefish	Least Concern	Not Assessed	No	Native	Yes	Yes
4	Marine fish	Ambassidae	<i>Ambassis kopsii</i>	Kops' glass perchlet	Not Assessed	Not Assessed	No	Native	Yes	Yes
5	Marine fish	Apogonidae	<i>Yarica hyalosoma</i>	Mangrove cardinalfish / humpbacked mangrove cardinalfish	Not Assessed	Not Assessed	No	Native	Yes	Yes
6	Marine fish	Carcharhinidae	<i>Carcharhinus melanopterus</i>	Black-tip reef shark	Vulnerable	Not Assessed	Yes	Native	No	Yes
7	Marine fish	Cichlidae	<i>Oreochromis mossambicus</i>	Common / Mozambique tilapia	Vulnerable	Not Assessed	Yes	Non-native	No	Yes
8	Marine fish	Clupeidae	<i>Anodontostoma chacunda</i>	Shortnose gizzard shad / Chacunda gizzard shad	Least Concern	Not Assessed	No	Native	Yes	Yes
9	Marine fish	Dasyatidae	<i>Himantura uarnak</i>	Honeycomb ray	Endangered	Not Assessed	Yes	NA	No	Yes
10	Marine fish	Gerreidae	<i>Gerres oyena</i>	Slender mojarra / silverbidy / Common mojarra	Least Concern	Not Assessed	No	Native	Yes	Yes
11	Marine fish	Gobiidae	<i>Acentrogobius janthinopterus</i>	Robust mangrove goby / green-spotted goby	Least Concern	Not Assessed	No	Non-native	Yes	Yes
12	Marine fish	Gobiidae	<i>Acentrogobius nebulosus</i>	Shadow goby	Least Concern	Not Assessed	No	Non-native	Yes	Yes
13	Marine fish	Gobiidae	<i>Hemigobius mingi</i>	Blue-eyed mullet goby	Not Assessed	Not Assessed	No	Non-native	Yes	Yes
14	Marine fish	Gobiidae	<i>Periophthalmus argentilineatus</i>	Silver-lined mudskipper	Least Concern	Not Assessed	No	Non-native	Yes	Yes
15	Marine fish	Gobiidae	<i>Periophthalmus walailakae</i>	Yellow-spotted mudskipper	Not Assessed	Not Assessed	No	Non-native	Yes	Yes
16	Marine fish	Gobiidae	<i>Pseudogobius javanicus</i>	Java fat-nose goby	Not Assessed	Not Assessed	No	Native	Yes	Yes
17	Marine fish	Gobiidae	<i>Stigmatogobius sadanundio</i>	Grey knight goby	Not Assessed	Not Assessed	No	Native	Yes	Yes
18	Marine fish	Hemiscylliidae	<i>Chiloscyllium indicum</i>	Slender bamboo shark	Vulnerable	Not Assessed	Yes	Native	No	Yes
19	Marine fish	Heriramphidae	<i>Hemiramphidae sp.</i>	Broad-nose halfbeak / broad-beak halfbeak	Not Assessed	Not Assessed	No	Native	Yes	Yes
20	Marine fish	Leiognathidae	<i>Leiognathidae sp.</i>	Ponyfish species	NA	NA	No	NA	Yes	Yes
21	Marine fish	Mugilidae	<i>Liza sp.</i>	NA	NA	NA	No	NA	Yes	Yes
22	Marine fish	NA	<i>Unidentified Catfish</i>	NA	NA	NA	No	NA	Yes	Yes
23	Marine fish	Narcinidae	<i>Temera hardwickii</i>	Hardwicke's electric ray	Vulnerable	Not Assessed	Yes	Native	No	Yes
24	Marine fish	Pomacentridae	<i>Amphiprion clarkii</i>	Clark's anemonefish	Not Assessed	Vulnerable	Yes	Native	No	Yes
25	Marine fish	Pomacentridae	<i>Amphiprion frenatus</i>	Tomato anemonefish	Least Concern	Vulnerable	Yes	Native	No	Yes
26	Marine fish	Pomacentridae	<i>Amphiprion ocellaris</i>	Ocellaris clownfish / clown anemonefish	Not Assessed	Vulnerable	Yes	Native	No	Yes
27	Marine fish	Pomacentridae	<i>Amphiprion perideraion</i>	Pink skunk anemonefish	Least Concern	Vulnerable	Yes	Native	No	Yes
28	Marine fish	Pomacentridae	<i>Amphiprion polymnus</i>	Saddleback anemonefish	Least Concern	Vulnerable	Yes	Native	No	Yes
29	Marine fish	Rhinidae	<i>Rhynchobatus djiddensis</i>	White-spotted guitarfish	Critically Endangered	Not Assessed	Yes	NA	No	Yes
30	Marine fish	Scatophagidae	<i>Scatophagus argus</i>	Spotted scat	Least Concern	Not Assessed	No	Native	Yes	Yes
31	Marine fish	Sillaginidae	<i>Sillago sihama</i>	Silver sillago / silver sand whiting / pasir	Least Concern	Not Assessed	No	Native	Yes	Yes
32	Marine fish	Sphyraenidae	<i>Sphyraena jello</i>	Picklehandle barracuda	Not Assessed	Not Assessed	No	Native	Yes	Yes
33	Marine fish	Syngnathidae	<i>Hippocampus comes</i>	Tiger-tailed seahorse	Vulnerable; CITES protected (Appendix II)	Vulnerable	Yes	NA	No	Yes
34	Marine fish	Syngnathidae	NA	Pipefish species	NA	NA	No	NA	Yes	Yes
35	Marine fish	Syngnathidae	<i>Hippocampus kuda</i>	Estuarine seahorse / spotted seahorse	Vulnerable	Vulnerable	Yes	Native	No	Yes
36	Marine fish	Toxotidae	<i>Toxotes jaculatrix</i>	Banded archerfish	Least Concern	Not Assessed	No	Native	Yes	Yes

Decapods

No.	Type	Family	Scientific Name	Common Name	Global Status (IUCN/CITES)	National Status (NParks, 2021)	Species of Conservation Significance	Native Status (NParks, 2021)	Recorded Species	Probable Species
1	Freshwater shrimp	Atyidae	<i>Caridina sp.</i>	NA	NA	NA	No	Native	Yes	Yes
2	Hermit crab	Coenobitidae	<i>Coenobita violascens</i>	Land hermit crab	Not Assessed	Vulnerable	Yes	NA	No	Yes
3	Hermit crab	Diogenidae	<i>Clibanarius infraspinitus</i>	Orange striped hermit crab	Not Assessed	Not Assessed	No	Non-native	Yes	Yes
4	Hermit crab	Diogenidae	<i>Clibanarius longitarsus</i>	Blue striped hermit crab	Not Assessed	Not Assessed	No	Non-native	Yes	Yes
5	Hermit crab	Diogenidae	<i>Diogenes sp.</i>	Tidal hermit crab	NA	NA	No	NA	Yes	Yes
6	Marine crab	Calappidae	<i>Calappa hepatica</i>	NA	Not Assessed	Vulnerable	Yes	NA	No	Yes
7	Marine crab	Calappidae	<i>Calappa philargius</i>	NA	Not Assessed	Vulnerable	Yes	NA	No	Yes
8	Marine crab	Campandriidae	<i>Baruna trigranulum</i>	NA	Not Assessed	Not Assessed	No	Non-native	Yes	Yes
9	Marine crab	Campandriidae	<i>Ilyogynnis sp.</i>	NA	NA	NA	No	NA	Yes	Yes
10	Marine crab	Dorippidae	<i>Dorippidae sp.</i>	Leaf porter crab	NA	NA	No	NA	Yes	Yes
11	Marine crab	Dotillidae	<i>Ilyoplax delsmanni</i>	NA	Not Assessed	Vulnerable	Yes	Native	No	Yes
12	Marine crab	Leucosiidae	<i>Praosia punctata</i>	NA	NA	NA	No	NA	Yes	Yes
13	Marine crab	Macrophthalmidae	<i>Ilyograpsus sp.</i>	NA	Not Assessed	Not Assessed	No	Non-native	Yes	Yes
14	Marine crab	Menippidae	<i>Myomenippe hardwickii</i>	Thunder crab	Not Assessed	Not Assessed	No	Non-native	Yes	Yes
15	Marine crab	Ocypodidae	<i>Gelasimus vocans</i>	Orange fiddler crab	Not Assessed	Not Assessed	No	Native	Yes	Yes
16	Marine crab	Ocypodidae	<i>Ocypodidae</i>	NA	NA	NA	No	NA	Yes	Yes
17	Marine crab	Ocypodidae	<i>Paracleistostoma depressum</i>	NA	Not Assessed	Not Assessed	No	Native	Yes	Yes
18	Marine crab	Ocypodidae	<i>Uca rosea</i>	Rosy fiddler crab	Not Assessed	Endangered	Yes	Native	No	Yes
19	Marine crab	Parthinoidea	<i>Rhinolambrus pelagicus</i>	Common elbow crab	Not Assessed	Vulnerable	Yes	NA	No	Yes
20	Marine crab	Pilumnidae	<i>Pilumnidae</i>	NA	NA	NA	No	NA	Yes	Yes
21	Marine crab	Portunidae	<i>Portunus pelagicus</i>	Flower crab	Not Assessed	Not Assessed	No	Non-native	Yes	Yes
22	Marine crab	Sesarmidae	<i>Episesarma versicolor</i>	Violet tree climbing crab	Not Assessed	Not Assessed	No	Non-native	Yes	Yes
23	Marine crab	Sesarmidae	<i>Fasciaria fasciatum</i>	NA	Not Assessed	Not Assessed	No	Non-native	Yes	Yes
24	Marine crab	Sesarmidae	<i>Parasesarma rutilimanum</i>	NA	Not Assessed	Not Assessed	No	Non-native	Yes	Yes
25	Marine crab	Sesarmidae	<i>Sarmatium germaini</i>	NA	Not Assessed	Endangered	Yes	NA	No	Yes
26	Marine crab	Sesarmidae	<i>Selatium brockii</i>	Mangrove tree-dwelling crab	Not Assessed	Not Assessed	No	Native	Yes	Yes
27	Marine crab	Sesarmidae	<i>Sesarmidae</i>	NA	NA	NA	No	NA	Yes	Yes
28	Marine crab	Varunidae	<i>Metaplax elegans</i>	Orange signaler crab	Not Assessed	Not Assessed	No	Non-native	Yes	Yes
29	Marine crab	Xanthidae	<i>Atergatis floridus</i>	NA	Not Assessed	Vulnerable	Yes	NA	No	Yes
30	Marine crab	Xanthidae	<i>Atergatis integerrimus</i>	Red egg crab	Not Assessed	Vulnerable	Yes	NA	No	Yes
31	Marine crab	Xanthidae	<i>Lophozozymus pictor</i>	Mosaic crab	Not Assessed	Endangered	Yes	NA	No	Yes
32	Marine crab	Xanthidae	<i>Pilodius sp.</i>	Pilodius rock crab	Not Assessed	Not Assessed	No	Non-native	Yes	Yes
33	Marine crab	Xanthidae	<i>Platypodia granulosa</i>	NA	Not Assessed	Endangered	Yes	NA	No	Yes
34	Marine crab	Xanthidae	<i>Xanthidae</i>	NA	NA	NA	No	NA	Yes	Yes
35	Marine shrimp	Alpheidae	<i>Alpheus sp.</i>	NA	NA	NA	No	NA	Yes	Yes
36	Marine shrimp	Alpheidae	<i>Athanas japonicus</i>	NA	Not Assessed	Vulnerable	Yes	NA	No	Yes
37	Marine shrimp	Alpheidae	<i>Athanas polymorphus</i>	NA	Not Assessed	Vulnerable	Yes	NA	No	Yes
38	Marine shrimp	Alpheidae	<i>Potamalpheops johnsoni</i>	NA	Not Assessed	Vulnerable	Yes	NA	No	Yes
39	Marine shrimp	Alpheidae	<i>Potamalpheops tigger</i>	NA	Not Assessed	Vulnerable	Yes	NA	No	Yes
40	Marine shrimp	Alpheidae	<i>Salmoneus singaporensis</i>	NA	Not Assessed	Critically Endangered	Yes	NA	No	Yes
41	Marine shrimp	Penaeidae	<i>Penaeus monodon</i>	NA	NA	NA	No	NA	Yes	Yes
42	Mud Lobster	Thalassinidae	NA	NA	NA	NA	Yes	NA	Yes*	Yes

Decapods

No.	Type	Family	Scientific Name	Common Name	Global Status (IUCN/CITES)	National Status (NParks, 2021)	Species of Conservation Significance	Native Status (NParks, 2021)	Recorded Species	Probable Species
43	Mud lobster	Thalassinidae	<i>Thalassina anomala</i>	NA	Not Assessed	Endangered	Yes	Native	No	Yes
44	Mud lobster	Thalassinidae	<i>Thalassina gracilis</i>	NA	Not Assessed	Endangered	Yes	Native	No	Yes
45	Mud shrimp	Upogebiidae	<i>Wolffogetia phuketensis</i>	NA	Not Assessed	Endangered	Yes	Native	No	Yes

*Mud mounds were recorded only.

No.	Family	Scientific Name	Common Name	Global Status (IUCN/CITES)	National Status (NParks, 2021)	Species of Conservation Significance	Native Status (NParks, 2021)	Recorded Species	Probable Species
1	Ampullariidae	<i>Pomacea canaliculata</i>	NA	Least Concern	Not Assessed	No	Non-native	Yes	Yes
2	Architectonicidae	<i>Architectonica perspectiva</i>	Perspective sundial shell	Not Assessed	Endangered	Yes	NA	No	Yes
3	Arcidae	<i>Anadara antiquata</i>	NA	Not Assessed	Not Assessed	No	Non-native	Yes	Yes
4	Arcidae	<i>Anadara inaequalis</i>	NA	Not Assessed	Not Assessed	No	Non-native	Yes	Yes
5	Arcidae	<i>Barbatia amygdalutostum</i>	NA	Not Assessed	Not Assessed	No	Non-native	Yes	Yes
6	Arcidae	<i>Barbatia obliquata</i>	NA	Not Assessed	Not Assessed	No	Non-native	Yes	Yes
7	Arcidae	<i>Tegillarca granosa</i>	Blood cockle	Not Assessed	Not Assessed	No	Non-native	Yes	Yes
8	Arcidae	<i>Tegillarca nodifera</i>	NA	NA	NA	No	NA	Yes	Yes
9	Assimineidae	<i>Optedicerus breviculum</i>	NA	Not Assessed	Not Assessed	No	Non-native	Yes	Yes
10	Batillariidae	<i>Batillaria zonalis</i>	Zoned horned shell	Not Assessed	Not Assessed	No	Non-native	Yes	Yes
11	Cassidae	<i>Phalium glaucum</i>	Grey bonnet	Not Assessed	Endangered	Yes	NA	No	Yes
12	Cerithiidae	<i>Cerithium coralium</i>	NA	Least Concern	Not Assessed	No	Non-native	Yes	Yes
13	Cerithiidae	<i>Cerithium trillii</i>	Trill's cerith	Not Assessed	Endangered	Yes	NA	No	Yes
14	Cerithiidae	<i>Clypeomorus bifasciata</i>	NA	Not Assessed	Not Assessed	No	Non-native	Yes	Yes
15	Cerithiidae	<i>Clypeomorus pellucida</i>	NA	Not Assessed	Not Assessed	No	Non-native	Yes	Yes
16	Chilodontidae	<i>Euchelus asper</i>	NA	Not Assessed	Not Assessed	No	Non-native	Yes	Yes
17	Chitonidae	<i>Acanthopleura gemmata</i>	Jewelled chiton	Not Assessed	Endangered	Yes	NA	No	Yes
18	Columbellidae	<i>Euplaca scripta</i>	Lettered dove shell	Not Assessed	Not Assessed	No	Non-native	Yes	Yes
19	Columbellidae	<i>Mitrella brookei</i>	NA	Not Assessed	Not Assessed	No	Non-native	Yes	Yes
20	Corbulidae	<i>Corbula</i> sp.	NA	NA	NA	No	NA	Yes	Yes
21	Costellariidae	<i>Vexillum gruneri</i>	NA	Not Assessed	Not Assessed	No	Non-native	Yes	Yes
22	Cypraeidae	<i>Cypraea arabica</i>	Arabian cowrie	Not Assessed	Vulnerable	Yes	NA	No	Yes
23	Cypraeidae	<i>Cypraea</i> sp.	NA	NA	NA	No	NA	Yes	Yes
24	Cypraeidae	<i>Cypraea tigris</i>	Tiger cowrie	Not Assessed	Endangered	Yes	NA	No	Yes
25	Cyrenidae	<i>Corbicula</i> sp.	NA	NA	NA	No	NA	Yes	Yes
26	Cyrenidae	<i>Geloina coaxans</i>	Giant mud clam, lokan	Not Assessed	Not Assessed	No	Non-native	Yes	Yes
27	Cyrenidae	<i>Geloina expansa</i>	Giant mud clam, lokan	Not Assessed	Not Assessed	No	Non-native	Yes	Yes
28	Donacidae	<i>Donax faba</i>	NA	Not Assessed	Not Assessed	No	Non-native	Yes	Yes
29	Ellobiidae	<i>Cassidula aurisfelis</i>	NA	Least Concern	Not Assessed	No	Native	Yes	Yes
30	Ellobiidae	<i>Laemodonta</i> sp.	NA	NA	NA	No	NA	Yes	Yes
31	Epitoniidae	<i>Epitonium</i> sp. 1	NA	NA	NA	No	NA	Yes	Yes
32	Epitoniidae	<i>Epitonium</i> sp. 2	NA	NA	NA	No	NA	Yes	Yes
33	Fissurellidae	<i>Scutus unguis</i>	Hoof-shield limpet	Not Assessed	Endangered	Yes	NA	No	Yes
34	Galeommatidae	<i>Galeommatidae</i>	NA	NA	NA	No	NA	Yes	Yes
35	Idiosepiidae	<i>Idiosepius</i> sp.	NA	NA	NA	No	Non-native	Yes	Yes
36	Iravadiidae	<i>Iravadia bombayana</i>	NA	Not Assessed	Not Assessed	No	Non-native	Yes	Yes
37	Laternulidae	<i>Laternula</i> sp.	NA	NA	NA	No	NA	Yes	Yes
38	Littorinidae	<i>Littorina conica</i>	NA	Not Assessed	Not Assessed	No	Non-native	Yes	Yes
39	Lucinidae	<i>Anodontia edentula</i>	NA	Not Assessed	Not Assessed	No	Non-native	Yes	Yes
40	Lucinidae	<i>Austriella corrugata</i>	Corrugated lucine	Not Assessed	Not Assessed	No	Non-native	Yes	Yes
41	Lucinidae	<i>Lucinidae</i>	NA	NA	NA	No	NA	Yes	Yes
42	Macluridae	<i>Heterocardia gibbosula</i>	NA	Not Assessed	Not Assessed	No	Non-native	Yes	Yes
43	Macluridae	<i>Meropesta pellucida</i>	NA	NA	NA	No	NA	Yes	Yes
44	Macluridae	<i>Micromactra angulifera</i>	NA	NA	NA	No	NA	Yes	Yes
45	Macluridae	<i>Raeta pellicula</i>	NA	Not Assessed	Not Assessed	No	Non-native	Yes	Yes
46	Macluridae	<i>Raeta pulchella</i>	NA	Not Assessed	Not Assessed	No	Non-native	Yes	Yes
47	Marginellidae	<i>Cryptospira</i> sp.	NA	NA	NA	No	NA	Yes	Yes
48	Melongenidae	<i>Volegalea cochlidium</i>	Spiral melongena	Not Assessed	Not Assessed	No	Non-native	Yes	Yes
49	Mesodesmatidae	<i>Coccella horsfieldii</i>	NA	Not Assessed	Not Assessed	No	Non-native	Yes	Yes
50	Muricidae	<i>Chicoreus capucinus</i>	Mangrove murex	Not Assessed	Not Assessed	No	Non-native	Yes	Yes
51	Muricidae	<i>Drupella margariticola</i>	NA	Not Assessed	Not Assessed	No	Non-native	Yes	Yes
52	Muricidae	<i>Ergalatax contracta</i>	NA	Not Assessed	Not Assessed	No	Non-native	Yes	Yes
53	Muricidae	<i>Indothais gradata</i>	NA	Not Assessed	Not Assessed	No	Non-native	Yes	Yes
54	Muricidae	<i>Indothais javanica</i>	NA	Not Assessed	Not Assessed	No	Non-native	Yes	Yes
55	Muricidae	<i>Murex trapa</i>	Rare-spined murex	Endangered	Not Assessed	Yes	NA	No	Yes
56	Muricidae	<i>Muricidae</i>	NA	NA	NA	No	NA	Yes	Yes
57	Muricidae	<i>Orania bimacronata</i>	NA	NA	NA	No	NA	Yes	Yes
58	Muricidae	<i>Semiricinula fusca</i>	NA	Not Assessed	Not Assessed	No	Non-native	Yes	Yes

No.	Family	Scientific Name	Common Name	Global Status (IUCN/CITES)	National Status (NParks, 2021)	Species of Conservation Significance	Native Status (NParks, 2021)	Recorded Species	Probable Species
59	Mytilidae	<i>Lithophaga sp.</i>	NA	NA	NA	No	NA	Yes	Yes
60	Mytilidae	<i>Modiolus sp.</i>	NA	NA	NA	No	NA	Yes	Yes
61	Mytilidae	<i>Perna viridis</i>	NA	Not Assessed	Not Assessed	No	Non-native	Yes	Yes
62	Nassariidae	<i>Nassarius crematus</i>	NA	NA	NA	No	NA	Yes	Yes
63	Nassariidae	<i>Nassarius crenoliratus</i>	NA	Not Assessed	Not Assessed	No	Non-native	Yes	Yes
64	Nassariidae	<i>Nassarius echinatus</i>	Prickly whelk	Not Assessed	Not Assessed	No	Non-native	Yes	Yes
65	Nassariidae	<i>Nassarius fuscus</i>	NA	Not Assessed	Not Assessed	No	Non-native	Yes	Yes
66	Nassariidae	<i>Nassarius jacksonianus</i>	Mud whelk	Not Assessed	Not Assessed	No	Non-native	Yes	Yes
67	Nassariidae	<i>Nassarius livescens</i>	Common whelk	Not Assessed	Not Assessed	No	Non-native	Yes	Yes
68	Nassariidae	<i>Nassarius nodifer</i>	NA	Not Assessed	Not Assessed	No	Non-native	Yes	Yes
69	Nassariidae	<i>Nassarius nodiferus</i>	NA	NA	NA	No	NA	Yes	Yes
70	Nassariidae	<i>Nassarius olivaceus</i>	Olive whelk	Not Assessed	Not Assessed	No	Non-native	Yes	Yes
71	Nassariidae	<i>Nassarius pullus</i>	Dog whelk	Not Assessed	Not Assessed	No	Non-native	Yes	Yes
72	Nassariidae	<i>Nassarius stolatus</i>	NA	Not Assessed	Not Assessed	No	Non-native	Yes	Yes
73	Nassariidae	<i>Nassarius teretiusculus</i>	NA	Not Assessed	Not Assessed	No	Non-native	Yes	Yes
74	Naticidae	<i>Paratectonica tigrina</i>	NA	NA	NA	No	NA	Yes	Yes
75	Neritidae	<i>Cithon oualaniense</i>	NA	NA	Vulnerable	Yes	Native	Yes	Yes
76	Neritidae	<i>Neripteron violaceum</i>	NA	Not Assessed	Not Assessed	No	Non-native	Yes	Yes
77	Neritidae	<i>Nerita balteata</i>	Lined nerite	Not Assessed	Not Assessed	No	Non-native	Yes	Yes
78	Neritidae	<i>Nerita histrio</i>	Scaled nerite	Not Assessed	Not Assessed	No	Non-native	Yes	Yes
79	Neritidae	<i>Nerita planospira</i>	Flat-spire nerite	Not Assessed	Vulnerable	Yes	NA	No	Yes
80	Ostreidae	<i>Ostreidae</i>	NA	NA	NA	No	NA	Yes	Yes
81	Pachychilidae	<i>Faunus ater</i>	NA	Least Concern	Vulnerable	Yes	Native	No	Yes
82	Pectinidae	<i>Pectinidae</i>	NA	NA	NA	No	NA	Yes	Yes
83	Pharidae	<i>Pharidae</i>	NA	NA	NA	No	NA	Yes	Yes
84	Pinnidae	<i>Pinna bicolor</i>	Two-coloured fan shell	Not Assessed	Vulnerable	Yes	NA	No	Yes
85	Pinnidae	<i>Pinna incurva</i>	Fan mussel	Critically Endangered	Not Assessed	Yes	NA	No	Yes
86	Pinnidae	<i>Pinna sp.</i>	NA	NA	NA	No	NA	Yes	Yes
87	Placunidae	<i>Placuna placenta</i>	Windowpane oyster	Not Assessed	Not Assessed	No	Non-native	Yes	Yes
88	Planorbidae	<i>Gyraulus bakeri</i>	NA	Vulnerable	Not Assessed	Yes	NA	No	Yes
89	Potamididae	<i>Pirenella alata</i>	NA	Not Assessed	Not Assessed	No	Non-native	Yes	Yes
90	Potamididae	<i>Pirenella cingulata</i>	Girdled horn snail	Not Assessed	Not Assessed	No	Non-native	Yes	Yes
91	Potamididae	<i>Pirenella microptera</i>	NA	Not Assessed	Not Assessed	No	Non-native	Yes	Yes
92	Potamididae	<i>Telescopium telescopium</i>	Telescope snail	Least Concern	Not Assessed	No	Native	Yes	Yes
93	Potamididae	<i>Terebralia sulcata</i>	Mud creeper	Not Assessed	Not Assessed	No	Non-native	Yes	Yes
94	Pteriidae	<i>Isognomon spathulatus</i>	NA	NA	NA	No	NA	Yes	Yes
95	Ranellidae	<i>Gyrineum natator</i>	Tuberculate gyre-triton	Not Assessed	Not Assessed	No	Non-native	Yes	Yes
96	Solenidae	<i>Solen sp.</i>	NA	Not Assessed	Not Assessed	No	Non-native	Yes	Yes
97	Strombidae	<i>Canarium urceus</i>	NA	Not Assessed	Vulnerable	Yes	NA	No	Yes
98	Strombidae	<i>Laevistrombus turturella</i>	Gong gong	Not Assessed	Not Assessed	No	Non-native	Yes	Yes
99	Strombidae	<i>Lambis lambis</i>	Spider conch	Not Assessed	Vulnerable	Yes	NA	No	Yes
100	Strombidae	<i>Strombus urceus</i>	Black-lipped conch	Not Assessed	Vulnerable	Yes	NA	No	Yes
101	Tellinidae	<i>Serratina capsoides</i>	NA	Not Assessed	Not Assessed	No	Non-native	Yes	Yes
102	Tellinidae	<i>Tellinidae</i>	NA	NA	NA	No	NA	Yes	Yes
103	Terebridae	<i>Terebridae</i>	NA	NA	NA	No	NA	Yes	Yes
104	Thiaridae	<i>Melanoides tuberculata</i>	NA	Least Concern	Not Assessed	No	Native	Yes	Yes
105	Tridacnidae	<i>Tridacna squamosa</i>	Fluted giant clam	Not Assessed; CITES protected (Appendix II)	Endangered	Yes	NA	No	Yes
106	Triviidae	<i>Trivia oryza</i>	NA	Not Assessed	Endangered	Yes	NA	No	Yes
107	Triviidae	<i>Trivirostra oryza</i>	NA	Not Assessed	Endangered	Yes	NA	No	Yes
108	Trochidae	<i>Monodonta labio</i>	Maculated top shell	Not Assessed	Not Assessed	No	Non-native	Yes	Yes
109	Trochidae	<i>Trochidae</i>	NA	NA	NA	No	NA	Yes	Yes
110	Trochidae	<i>Trochus niloticus</i>	NA	Not Assessed	Vulnerable	Yes	NA	No	Yes
111	Trochidae	<i>Umbonium vestiarium</i>	Button snail	Not Assessed	Not Assessed	No	Non-native	Yes	Yes
112	Truncatellidae	<i>Truncatella guerinii</i>	NA	Least Concern	Not Assessed	No	Native	Yes	Yes
113	Ungulinidae	<i>Diplodonta sp.</i>	NA	Not Assessed	Not Assessed	No	Non-native	Yes	Yes
114	Veneridae	<i>Anomalodiscus squamosus</i>	NA	Not Assessed	Not Assessed	No	Non-native	Yes	Yes
115	Veneridae	<i>Circe scripta</i>	NA	Not Assessed	Not Assessed	No	Non-native	Yes	Yes
116	Veneridae	<i>Circe undatina</i>	NA	NA	NA	No	NA	Yes	Yes

Molluscs

No.	Family	Scientific Name	Common Name	Global Status (IUCN/CITES)	National Status (NParks, 2021)	Species of Conservation Significance	Native Status (NParks, 2021)	Recorded Species	Probable Species
117	Veneridae	<i>Dosinia sp.</i>	NA	Not Assessed	Not Assessed	No	Non-native	Yes	Yes
118	Veneridae	<i>Gafrarium pectinatum</i>	NA	Not Assessed	Not Assessed	No	Non-native	Yes	Yes
119	Veneridae	<i>Gafrarium tumidum</i>	NA	Not Assessed	Not Assessed	No	Non-native	Yes	Yes
120	Veneridae	<i>Marcia hiantina</i>	NA	Not Assessed	Not Assessed	No	Non-native	Yes	Yes
121	Veneridae	<i>Marcia japonica</i>	NA	Not Assessed	Not Assessed	No	Non-native	Yes	Yes
122	Veneridae	<i>Pitar sp.</i>	NA	NA	NA	No	NA	Yes	Yes
123	Veneridae	<i>Placamen chloroticum</i>	NA	Not Assessed	Not Assessed	No	Non-native	Yes	Yes
124	Veneridae	<i>Protapes gallus</i>	NA	Not Assessed	Not Assessed	No	Non-native	Yes	Yes
125	Volutidae	<i>Cymbiola nobilis</i>	Noble volute	Not Assessed	Vulnerable	Yes	NA	No	Yes
126	Volutidae	<i>Melo melo</i>	Bailer shell	Not Assessed	Endangered	Yes	NA	No	Yes

Other Marine Species

No.	Taxon	Family	Scientific Name	Common Name	Global Status (IUCN/CITES)	National Status (Davison et al., 2008)	Species of Conservation Significance	Native Status	Recorded Species	Probable Species
1	Cnidarian	Diadumenidae	<i>Diadumene lineata</i>	NA	Not Assessed	Least Concern	No	Non-native	Yes	Yes
2	Echinoderm	Asterinidae	<i>Aquilonastra coronata</i>	Crown sea star / rock star	Not Assessed	Not Assessed	No	Non-native	Yes	Yes
3	Echinoderm	Astropectinidae	<i>Astropecten indicus</i>	Plain sand star	NA	NA	No	NA	Yes	Yes
4	Echinoderm	Caudinidae	<i>Paracaudina australis</i>	NA	NA	NA	No	NA	Yes	Yes
5	Echinoderm	Synaptidae	<i>Anapta gracilis</i>	NA	Not Assessed	Not Assessed	No	Non-native	Yes	Yes
6	Nemertea	Limnositylochidae	<i>Limnositylochidae</i>	NA	NA	NA	No	NA	Yes	Yes
7	Nemertea	Nemertea	<i>Nemertea</i>	Pink ribbon worm	NA	NA	No	NA	Yes	Yes
8	Polychaete	Amphinomidae	<i>Eurythoe complanata</i>	NA	NA	NA	No	NA	Yes	Yes
9	Polychaete	Glyceridae	<i>Glycera unicornis</i>	NA	NA	NA	No	NA	Yes	Yes
10	Polychaete	Nereididae	<i>Neanthes glandicincta</i>	NA	Not Assessed	Not Assessed	No	Non-native	Yes	Yes
11	Xiphosura	Limulidae	<i>Carcinoscorpius rotundicauda</i>	Mangrove horseshoe crab	Data deficient	Vulnerable	Yes	Native	Yes	Yes

Appendix F
Fauna Survey Data

Date	Cycle	Route	Waypoint	Latitude	Longitude	Sampling point	Latitude	Longitude	Quadrat	Time (24h)	Scientific name	Quantity	Observation type (seen/heard/catched/scar/other signs)	Photo no.	Survey method (targeted/incidental/point count/trapping)	Remarks
2/16/2022	1	Shorebird Survey	HB2999	1.468104	103.978293	SB_01	1.407814985	103.977986	NA	1521	<i>Actitis hypoleucos</i>	1	Seen		Targeted	
2/16/2022	1	Shorebird Survey	HB2999	1.468295	103.97824	SB_01	1.407814985	103.977986	NA	1610	<i>Actitis hypoleucos</i>	1	Seen		Targeted	foraging inside pond (approx location) for few minutes, then fly out seawards
2/16/2022	NA	NA	NA	1.468295	103.97824	NA	NA	NA	NA	2029	<i>Actitis americana</i>	1	Seen		Incidental	moving along the edge of water, all the way. Seen during setting of bait trap
2/16/2022	1	11	HB3000	1.40764977	103.975841	NA	NA	NA	NA	2029	<i>Cyngopsis brachyotis</i>	1	Seen		Targeted	HB5004-07
2/16/2022	1	11	HB3001	1.40771013	103.975838	NA	NA	NA	NA	2032	<i>Caprimulgus macrurus</i>	2	Heard		Targeted	
2/16/2022	1	11	HB3002	1.40788993	103.975837	NA	NA	NA	NA	2035	<i>Polydactylus isocnematus</i>	1	Seen		Targeted	
2/16/2022	1	11	HB3003	1.40806035	103.975834	NA	NA	NA	NA	2036	<i>Fregata acaucivora</i>	1	Seen		Targeted	
2/16/2022	1	11	HB3004	1.40807892	103.975827	NA	NA	NA	NA	2044	<i>Caprimulgus macrurus</i>	2	Heard		Targeted	
2/16/2022	1	11	HB3004	1.40807892	103.975827	NA	NA	NA	NA	2044	<i>Polydactylus isocnematus</i>	1	Heard		Targeted	
2/16/2022	1	11	HB3004	1.40807892	103.975827	NA	NA	NA	NA	2044	<i>Polydactylus isocnematus</i>	1	Seen		Targeted	
2/16/2022	1	11	HB3004	1.40807892	103.975827	NA	NA	NA	NA	2044	<i>Tringa rostrata</i>	2	Seen		Incidental	while walking to start point of 101
2/16/2022	1	11	HB3005	1.40813377	103.976096	NA	NA	NA	NA	2046	<i>Arthropus modestus</i>	1	Seen		Targeted	HB500-1.4VS464-06
2/16/2022	1	11	HB3006	1.40868633	103.976068	NA	NA	NA	NA	2057	<i>Fregata acaucivora</i>	1	Seen		Targeted	
2/16/2022	1	11	HB3007	1.40810397	103.976213	NA	NA	NA	NA	2058	<i>Indotyphlops braminus</i>	1	Seen		Targeted	burrowed into soil
2/16/2022	1	11	HB3007	1.40810397	103.976213	NA	NA	NA	NA	2058	<i>Otus longi</i>	1	Heard		Targeted	
2/16/2022	1	11	HB3008	1.409078976	103.976568	NA	NA	NA	NA	2103	<i>Aethya prasinia</i>	1	Seen		Targeted	
2/16/2022	1	11	HB3008	1.409078976	103.976568	NA	NA	NA	NA	2103	<i>Caprimulgus macrurus</i>	1	Heard		Targeted	
2/16/2022	1	11	HB3009	1.407575011	103.977628	NA	NA	NA	NA	2119	<i>Scolopocryptus</i>	2	Seen		Incidental	
2/16/2022	1	11	HB3009	1.407575011	103.977628	NA	NA	NA	NA	2119	<i>Facsimilia fasciatum</i>	1	Seen		Incidental	SS to id
2/16/2022	1	11	HB3010	1.407953035	103.978395	NA	NA	NA	NA	2131	<i>Hemirhamphus sp.</i>	TMTC	Seen		Incidental	
2/16/2022	1	12	HB3011	1.409984005	103.977202	NA	NA	NA	NA	2142	<i>Caprimulgus macrurus</i>	1	Heard		Targeted	
2/16/2022	1	12	HB3011	1.409984005	103.977202	NA	NA	NA	NA	2142	<i>Undulidifid Pteropodidae</i>	1	Seen		Targeted	
2/16/2022	1	12	HB3012	1.409587003	103.977817	NA	NA	NA	NA	2149	<i>Otus longi</i>	1	Heard		Targeted	
2/16/2022	1	12	HB3012	1.409587003	103.977817	NA	NA	NA	NA	2149	<i>Polydactylus isocnematus</i>	1	Seen		Targeted	
2/16/2022	1	12	HB3013	1.410136018	103.978186	NA	NA	NA	NA	2218	<i>Undulidifid</i>	1	Seen		Targeted	
2/16/2022	1	12	HB3014	1.409424981	103.978834	NA	NA	NA	NA	2230	<i>Pycnonotus aplaris</i>	1	Seen		Targeted	Roosting, flew away
2/16/2022	1	12	HB3015	1.408766251	103.978888	NA	NA	NA	NA	2236	<i>Aethya prasinia</i>	1	Seen		Targeted	
2/16/2022	1	12	HB3015	1.408766251	103.978888	NA	NA	NA	NA	2236	<i>Caprimulgus macrurus</i>	1	Heard		Targeted	
2/16/2022	1	12	HB3017	1.408515964	103.978905	NA	NA	NA	NA	2253	<i>Aethya prasinia</i>	1	Seen		Targeted	
2/16/2022	NA	12	NA	1.4107577	103.977462	NA	NA	NA	NA	1750	<i>Ptila moluccana</i>	1	Heard		Incidental	When walking out after end of T02, pale brown to green
2/16/2022	NA	12	NA	1.40749485	103.977096	NA	NA	NA	NA	1630-1800	<i>Leptocoma callosirostris</i>	1	Heard		Incidental	White unloading staff from van seen during shorebird survey
2/23/2022	1	11	JW1583	1.40763402	103.975795	NA	NA	NA	NA	925	<i>Rhycolinus haemorrhoidalis</i>	1	Seen		Targeted	
2/23/2022	1	11	JW1584	1.40762008	103.976535	NA	NA	NA	NA	932	<i>Stenophranus purpuratus</i>	1	Seen		Targeted	
2/23/2022	1	11	JW1585	1.40818016	103.975578	NA	NA	NA	NA	942	<i>Raphania zigaga</i>	1	Seen		Targeted	HW4122
2/23/2022	1	11	JW1585	1.40818016	103.975578	NA	NA	NA	NA	942	<i>Thyridus himalayensis</i>	1	Seen		Targeted	
2/23/2022	1	11	JW1585	1.40818016	103.975578	NA	NA	NA	NA	947	<i>Tetragonalia valdovi</i>	1	Seen		Targeted	
2/23/2022	1	12	JW1586	1.40879497	103.976236	NA	NA	NA	NA	1024	<i>Phalaena</i>	1	Heard		Incidental	
2/23/2022	1	11	JW1586	1.40879497	103.976236	NA	NA	NA	NA	1024	<i>Melococina abbotti</i>	1	Heard		Targeted	
2/23/2022	1	11	JW1587	1.40864608	103.976353	NA	NA	NA	NA	1030	<i>Coprosiphon malabaricus</i>	1	Seen		Targeted	
2/23/2022	1	11	JW1588	1.40875401	103.976228	NA	NA	NA	NA	1034	<i>Oxalis metallic</i>	1	Seen		Targeted	HW4129_30_24
2/23/2022	1	11	JW1588	1.40875401	103.976228	NA	NA	NA	NA	1034	<i>Sphinx subfranciscus</i>	1	Seen		Targeted	Male specimen
2/23/2022	1	11	JW1588	1.40875401	103.976228	NA	NA	NA	NA	1034	<i>Xanthostictus</i>	1	Seen		Targeted	
2/23/2022	1	11	JW1588	1.40875401	103.976228	NA	NA	NA	NA	1034	<i>Alnus sp.</i>	1	Seen		Targeted	
2/23/2022	1	11	JW1588	1.40875401	103.976228	NA	NA	NA	NA	1034	<i>Eumenes sp.</i>	1	Seen		Targeted	Emperor sp. foraging on 2 light paths
2/23/2022	1	11	JW1589	1.40946035	103.976719	NA	NA	NA	NA	1050	<i>Camponotus caryillii</i>	1	Seen		Targeted	Pending ID, care
2/23/2022	1	11	JW1589	1.40946035	103.976719	NA	NA	NA	NA	1050	<i>Agrotis optima</i>	1	Seen		Targeted	HW4142_43
2/23/2022	1	11	JW1590	1.40901032	103.976907	NA	NA	NA	NA	1052	<i>Agrotis optima</i>	3	Seen		Targeted	HW4145
2/23/2022	1	11	JW1590	1.40901032	103.976907	NA	NA	NA	NA	1052	<i>Camponotus caryillii</i>	1	Seen		Targeted	HW4146
2/23/2022	1	11	JW1591	1.40879497	103.977239	NA	NA	NA	NA	1057	<i>Leptocryptus variegatus</i>	1	Seen		Targeted	
2/23/2022	1	11	JW1592	1.40857035	103.977233	NA	NA	NA	NA	1100	<i>Liris sulcatellus</i>	1	Seen		Targeted	
2/23/2022	1	11	JW1593	1.40846608	103.977347	NA	NA	NA	NA	1101	<i>Amathus philippus philippus</i>	1	Seen		Targeted	
2/23/2022	1	11	JW1593	1.40846608	103.977347	NA	NA	NA	NA	1101	<i>Panola flavescens</i>	1	Seen		Targeted	
2/23/2022	1	11	JW1593	1.40846608	103.977347	NA	NA	NA	NA	1101	<i>Apis cerana</i>	TMTC	Seen		Targeted	Need in log
2/23/2022	1	11	JW1593	1.40846608	103.977347	NA	NA	NA	NA	1101	<i>Macrodactylus cora</i>	1	Seen		Targeted	HW4154_55
2/23/2022	1	11	JW1594	1.40749203	103.977378	NA	NA	NA	NA	1102	<i>Liris sulcatellus</i>	1	Seen		Targeted	
2/23/2022	1	11	JW1595	1.40762962	103.977616	NA	NA	NA	NA	1114	<i>Macrodactylus cora</i>	1	Seen		Targeted	HW4157_59
2/23/2022	1	11	JW1596	1.40769301	103.977791	NA	NA	NA	NA	1116	<i>Rhycolinus phyllis</i>	1	Seen		Targeted	
2/23/2022	1	11	JW1597	1.40749412	103.978320	NA	NA	NA	NA	1122	<i>Tringa erythropus</i>	1	Seen		Targeted	HW4164_65
2/23/2022	1	11	JW1597	1.40749412	103.978320	NA	NA	NA	NA	1122	<i>Rhycolinus phyllis</i>	1	Seen		Targeted	
2/23/2022	1	12	JW1598	1.40961499	103.977774	NA	NA	NA	NA	1138	<i>Egophthalmia virgata</i>	1	Seen		Targeted	HW4170_80
2/23/2022	1	12	JW1598	1.40961499	103.977774	NA	NA	NA	NA	1138	<i>Agrotis optima</i>	1	Seen		Targeted	HW4173_74
2/23/2022	1	12	JW1598	1.40961499	103.977774	NA	NA	NA	NA	1138	<i>Agrotis optima</i>	1	Seen		Targeted	
2/23/2022	1	12	JW1599	1.410311032	103.978035	NA	NA	NA	NA	1148	<i>Apis cerana</i>	5	Seen		Targeted	
2/23/2022	1	12	JW1599	1.410311032	103.978035	NA	NA	NA	NA	1148	<i>Stenophranus purpuratus</i>	1	Seen		Targeted	Feeding on flowers on ground
2/23/2022	1	12	JW1599	1.410311032	103.978035	NA	NA	NA	NA	1148	<i>Alchorhynchium argenteum</i>	1	Seen		Targeted	
2/23/2022	1	12	JW1599	1.410311032	103.978035	NA	NA	NA	NA	1148	<i>Scaphiopus javanicus</i>	1	Seen		Targeted	
2/23/2022	1	12	JW1600	1.41062624	103.978488	NA	NA	NA	NA	1203	<i>Orthotermus subniger</i>	1	Seen		Targeted	HW4184
2/23/2022	1	12	JW1601	1.41062624	103.978488	NA	NA	NA	NA	1203	<i>Brachydytes chalybea</i>	1	Seen		Targeted	
2/23/2022	1	12	JW1601	1.41062624	103.978488	NA	NA	NA	NA	1203	<i>Alchorhynchium argenteum</i>	1	Seen		Targeted	
2/23/2022	1	12	JW1601	1.41062624	103.978488	NA	NA	NA	NA	1203	<i>Raphania zigaga</i>	1	Seen		Targeted	
2/23/2022	1	12	JW1601	1.41062624	103.978488	NA	NA	NA	NA	1203	<i>Sphinx subfranciscus</i>	1	Seen		Targeted	
2/23/2022	1	12	JW1601													

Date	Cycle	Route	Waypoint	Latitude	Longitude	Sampling point	Latitude	Longitude	Quadrat	Time (24h)	Scientific name	Quantity	Observation type (seen/heard/caught/sat/other signs)	Photo no.	Survey method (targeted/incidental/point count/trapping)	Remarks
2/17/2022	1	T1	11735	140870015	103.977187	NA	NA	NA	NA	808	<i>Pycnonotus plumosus</i>	2	Heard		Targeted	
2/17/2022	1	T1	11736	140869501	103.977267	NA	NA	NA	NA	808	<i>Copsychus saularis</i>	2	Heard		Targeted	
2/17/2022	1	T1	11736	140869501	103.977267	NA	NA	NA	NA	808	<i>Pycnonotus zeylanicus</i>	2	Heard		Targeted	
2/17/2022	1	T1	11736	140869501	103.977267	NA	NA	NA	NA	808	<i>Alcedo atthis</i>	2	Heard		Targeted	
2/17/2022	1	T1	11736	140869501	103.977267	NA	NA	NA	NA	808	<i>Orithotomus ruficeps</i>	2	Heard		Targeted	
2/17/2022	1	T1	11737	140841991	103.977261	NA	NA	NA	NA	811	<i>Acridothera tristis</i>	10	Seen		Targeted	
2/17/2022	1	T1	11737	140841991	103.977261	NA	NA	NA	NA	811	<i>Orithotomus ruficeps</i>	4	Heard		Targeted	
2/17/2022	1	T1	11737	140841991	103.977261	NA	NA	NA	NA	811	<i>Mergops viridis</i>	1	Seen		Targeted	
2/17/2022	1	T1	11738	140819959	103.977402	NA	NA	NA	NA	813	<i>Halcyon leucogaster</i>	1	Heard		Targeted	
2/17/2022	1	T1	11738	140819959	103.977402	NA	NA	NA	NA	813	<i>Nisus cirrhatus</i>	1	Heard		Targeted	
2/17/2022	1	T1	11738	140819959	103.977402	NA	NA	NA	NA	815	<i>Trogon verians</i>	2	Seen		Targeted	
2/17/2022	1	T1	11738	140819959	103.977402	NA	NA	NA	NA	815	<i>Alcedo atthis</i>	2	Seen		Targeted	
2/17/2022	1	T1	11739	140781062	103.977512	NA	NA	NA	NA	818	<i>Orithotomus ruficeps</i>	2	Heard		Targeted	
2/17/2022	1	T1	11739	140781062	103.977512	NA	NA	NA	NA	818	<i>Orithotomus ruficeps</i>	1	Seen		Targeted	
2/17/2022	1	T1	11740	140762002	103.977578	NA	NA	NA	NA	819	<i>Rhipidura javanica</i>	1	Heard		Targeted	
2/17/2022	1	T1	11740	140762002	103.977578	NA	NA	NA	NA	819	<i>Acridothera tristis</i>	1	Seen		Targeted	
2/17/2022	1	T1	11740	140762002	103.977578	NA	NA	NA	NA	819	<i>Acridothera tristis</i>	1	Seen		Targeted	
2/17/2022	1	T1	11740	140762002	103.977578	NA	NA	NA	NA	819	<i>Acridothera tristis</i>	1	Seen		Targeted	
2/17/2022	1	T1	11740	140762002	103.977578	NA	NA	NA	NA	819	<i>Acridothera tristis</i>	1	Seen		Targeted	
2/17/2022	1	T1	11743	140763971	103.977753	NA	NA	NA	NA	819	<i>Orithotomus ruficeps</i>	4	Heard		Targeted	
2/17/2022	1	T1	11743	140763971	103.977753	NA	NA	NA	NA	825	<i>Cinnyris jugularis</i>	2	Seen		Targeted	
2/17/2022	1	T1	11744	140778108	103.97797	NA	NA	NA	NA	826	<i>Mergops viridis</i>	1	Seen		Targeted	
2/17/2022	1	T1	11744	140778108	103.97797	NA	NA	NA	NA	829	<i>Orithotomus ruficeps</i>	6	Seen		Targeted	
2/17/2022	1	T1	11745	140785021	103.978147	NA	NA	NA	NA	830	<i>Muscicapa dauurica</i>	1	Seen		Targeted	
2/17/2022	1	T1	11746	140792979	103.978333	NA	NA	NA	NA	836	<i>Acridothera tristis</i>	2	Heard		Targeted	
2/17/2022	1	T1	11746	140792979	103.978333	NA	NA	NA	NA	836	<i>Oricola chinensis</i>	2	Seen		Targeted	
2/17/2022	1	T1	11746	140792979	103.978333	NA	NA	NA	NA	836	<i>Acridothera tristis</i>	10	Seen		Targeted	
2/17/2022	1	T1	11746	140792979	103.978333	NA	NA	NA	NA	836	<i>Cinnyris jugularis</i>	1	Seen		Targeted	
2/17/2022	1	T1	11747	140772975	103.977936	NA	NA	NA	NA	836	<i>Phylloscopus bonalis</i>	1	Heard		Targeted	
2/17/2022	1	T1	11747	140772975	103.977936	NA	NA	NA	NA	836	<i>Micropternis brachyurus</i>	1	Heard		Incidental	
2/17/2022	1	T2	11748	140889705	103.977067	NA	NA	NA	NA	849	<i>Dryobates javanicus</i>	1	Seen		Targeted	
2/17/2022	1	T2	11748	140889705	103.977067	NA	NA	NA	NA	849	<i>Acridothera javanica</i>	1	Heard		Targeted	
2/17/2022	1	T2	11748	140889705	103.977067	NA	NA	NA	NA	849	<i>Trogon verians</i>	1	Heard		Targeted	
2/17/2022	1	T2	11748	140889705	103.977067	NA	NA	NA	NA	849	<i>Nisus cirrhatus</i>	1	Heard		Targeted	
2/17/2022	1	T2	11748	140889705	103.977067	NA	NA	NA	NA	849	<i>Oricola chinensis</i>	1	Heard		Targeted	
2/17/2022	1	T2	11748	140889705	103.977067	NA	NA	NA	NA	849	<i>Rhipidura javanica</i>	1	Heard		Targeted	
2/17/2022	1	T2	11749	140913361	103.977136	NA	NA	NA	NA	851	<i>Phylloscopus bonalis</i>	1	Heard		Targeted	
2/17/2022	1	T2	11749	140913361	103.977136	NA	NA	NA	NA	851	<i>Oricola chinensis</i>	1	Heard		Targeted	
2/17/2022	1	T2	11750	140914029	103.977305	NA	NA	NA	NA	853	<i>Pycnonotus plumosus</i>	1	Heard		Targeted	
2/17/2022	1	T2	11750	140914029	103.977305	NA	NA	NA	NA	853	<i>Acridothera tristis</i>	1	Heard		Targeted	
2/17/2022	1	T2	11752	140949992	103.977671	NA	NA	NA	NA	855	<i>Pycnonotus plumosus</i>	2	Heard		Targeted	
2/17/2022	1	T2	11752	140949992	103.977671	NA	NA	NA	NA	855	<i>Pycnonotus plumosus</i>	2	Heard		Targeted	
2/17/2022	1	T2	11753	140986002	103.977891	NA	NA	NA	NA	857	<i>Altrixiparus malacurus</i>	1	Heard		Targeted	
2/17/2022	1	T2	11753	140986002	103.977891	NA	NA	NA	NA	857	<i>Mircops viridis</i>	1	Seen		Targeted	
2/17/2022	1	T2	11754	140998999	103.97795	NA	NA	NA	NA	858	<i>Copsychus saularis</i>	1	Heard		Targeted	
2/17/2022	1	T2	11755	141017994	103.977976	NA	NA	NA	NA	859	<i>Muscicapa fascicularis</i>	20	Seen		Many babies	
2/17/2022	1	T2	11756	141038959	103.977855	NA	NA	NA	NA	901	<i>Muscicapa fascicularis</i>	20	Seen		Many babies	
2/17/2022	1	T2	11756	141038959	103.977855	NA	NA	NA	NA	901	<i>Agropopoda insularis</i>	1	Seen		Incidental	
2/17/2022	1	T2	11757	141081864	103.977994	NA	NA	NA	NA	904	<i>Actinodactyla javanica</i>	3	Heard		Targeted	
2/17/2022	1	T2	11757	141081864	103.977994	NA	NA	NA	NA	904	<i>Dicaeum everedii</i>	1	Heard		Targeted	
2/17/2022	1	T2	11757	141081864	103.977994	NA	NA	NA	NA	904	<i>Pycnonotus plumosus</i>	1	Heard		Targeted	
2/17/2022	1	T2	11757	141081864	103.977994	NA	NA	NA	NA	904	<i>Picus vittatus</i>	1	Heard		Targeted	
2/17/2022	1	T2	11758	141092506	103.978061	NA	NA	NA	NA	905	<i>Muscicapa fascicularis</i>	1	Seen		Targeted	
2/17/2022	1	T2	11758	141092506	103.978061	NA	NA	NA	NA	905	<i>Pycnonotus plumosus</i>	2	Seen		Targeted	
2/17/2022	1	T2	11758	141092506	103.978061	NA	NA	NA	NA	905	<i>Mergops viridis</i>	1	Heard		Targeted	
2/17/2022	1	T2	11759	141081027	103.978325	NA	NA	NA	NA	909	<i>Anthus trichospus</i>	1	Heard		Targeted	
2/17/2022	1	T2	11759	141081027	103.978325	NA	NA	NA	NA	909	<i>Dicaeum everedii</i>	1	Heard		Targeted	
2/17/2022	1	T2	11760	141064889	103.978438	NA	NA	NA	NA	912	<i>Trogon verians</i>	2	Seen		Targeted	
2/17/2022	1	T2	11760	141064889	103.978438	NA	NA	NA	NA	912	<i>Mircops viridis</i>	1	Seen		Targeted	
2/17/2022	1	T2	11762	141061797	103.978595	NA	NA	NA	NA	912	<i>Agelaius panyasensis</i>	6	Seen		Targeted	
2/17/2022	1	T2	11762	141061797	103.978595	NA	NA	NA	NA	912	<i>Orithotomus ruficeps</i>	1	Seen		Targeted	
2/17/2022	1	T2	11763	141056027	103.978363	NA	NA	NA	NA	916	<i>Copsychus saularis</i>	1	Heard		Targeted	
2/17/2022	1	T2	11763	141056027	103.978363	NA	NA	NA	NA	916	<i>Rhipidura javanica</i>	1	Heard		Targeted	
2/17/2022	1	T2	11763	141056027	103.978363	NA	NA	NA	NA	916	<i>Acridothera tristis</i>	1	Heard		Targeted	
2/17/2022	1	T2	11765	141052099	103.978687	NA	NA	NA	NA	917	<i>Halcyon leucogaster</i>	2	Heard		Targeted	
2/17/2022	1	T2	11765	141052099	103.978687	NA	NA	NA	NA	917	<i>Orithotomus ruficeps</i>	1	Heard		Targeted	
2/17/2022	1	T2	11765	141052099	103.978687	NA	NA	NA	NA	917	<i>Copsychus saularis</i>	1	Heard		Targeted	
2/17/2022	1	T2	11766	141037274	103.978104	NA	NA	NA	NA	920	<i>Paradiseus muscivorus</i>	1	Seen		Scat	
2/17/2022	1	T2	11767	141012009	103.978738	NA	NA	NA	NA	923	<i>Copsychus saularis</i>	1	Seen		Targeted	
2/17/2022	1	T2	11767	141012009	103.978738	NA	NA	NA	NA	923	<i>Orithotomus ruficeps</i>	1	Seen		Targeted	
2/17/2022	1	T2	11767	141012009	103.978738	NA	NA	NA	NA	923	<i>Pycnonotus plumosus</i>	1	Seen		Targeted	
2/17/2022	1	T2	11767	141012009	103.978738	NA	NA	NA	NA	923	<i>Leptocoma brachyloma</i>	1	Seen		Male	HB 5026-5028
2/17/2022	1	T2	11767	141012009	103.978738	NA	NA	NA	NA	923	<i>Cinnyris jugularis</i>	1	Seen		Targeted	
2/17/2022	1	T2	11768	140921006	103.978797	NA	NA	NA	NA	930	<i>Acridothera tristis</i>	1	Heard		Targeted	
2/17/2022	1	T2	11768	140921006	103.978797	NA	NA	NA	NA	930	<i>Oricola chinensis</i>	1	Heard		Targeted	
2/17/2022	1	T2	11769	140914707	103.978922	NA	NA	NA	NA	930	<i>Phylloscopus coleroides</i>	1	Heard		Targeted	
2/17/2022	1	T2	11770	140888019	103.978831	NA	NA	NA	NA	933	<i>Pycnonotus zeylanicus</i>	2	Heard		Targeted	
2/17/2022	1	T2	11772	140875833	103.978839	NA	NA	NA	NA	934	<i>Sus scrofa</i>	1	Seen		Targeted	
2/17/2022	1	T2	11772	140875833	103.978839	NA	NA	NA	NA	934	<i>Phylloscopus bonalis</i>	2	Seen		Targeted	
2/17/2022	1	T2	11772	140875833	103.978839	NA	NA	NA	NA	934	<i>Actitis hypoleucos</i>	1	Heard		Targeted	
2/17/2022	1	T2	11772	140875833	103.978839	NA	NA	NA	NA	934	<i>Orithotomus ruficeps</i>	2	Seen		Targeted	
2/17/2022	1	T2	11774	140838971	103.978891	NA	NA	NA	NA	937	<i>Carpodacus macularius</i>	1	Seen		Targeted	
2/17/2022	1	T2	11774	140838971	103.978891	NA	NA	NA	NA	939	<i>Orithotomus ruficeps</i>	3	Heard		Targeted	
2/17/2022	1	T2	11774	140838971	103.978891	NA	NA	NA	NA	939	<i>Orith</i>					

Date	Cycle	Route	Waypoint	Latitude	Longitude	Sampling point	Latitude	Longitude	Quadrat	Time (24h)	Scientific name	Quantity	Observation type (seen/heard/caught/sat/other signs)	Photo no.	Survey method (targeted/incidental/point count/trapping)	Remarks
3/1/2022	1	Mudflat survey	NA	NA	NA	MF06	1.40825233	103.9774502	12	1345-1800	<i>Nassarius pulillus</i>	2	Seen		Targeted	
3/1/2022	1	Mudflat survey	NA	NA	NA	MF06	1.40825233	103.9774502	12	1345-1800	<i>Nassarius jacksoniana</i>	2	Seen	Specimen	Targeted	
3/1/2022	1	Mudflat survey	NA	NA	NA	MF06	1.40825233	103.9774502	12	1345-1800	<i>Dicathema lineata</i>	2	Seen		Targeted	
3/1/2022	1	Mudflat survey	NA	NA	NA	MF06	1.40825233	103.9774502	12	1345-1800	<i>Doinia sp.</i>	2	Seen		Targeted	
3/1/2022	1	Mudflat survey	NA	NA	NA	MF06	1.40825233	103.9774502	12	1345-1800	<i>Dicathema brevicaudum</i>	3	Seen		Targeted	
3/1/2022	1	Mudflat survey	NA	NA	NA	MF06	1.40825233	103.9774502	12	1345-1800	<i>Marea japonica</i>	2	Seen		Targeted	
3/1/2022	1	Mudflat survey	NA	NA	NA	MF06	1.40825233	103.9774502	12	1345-1800	<i>Pireneis cinquiola</i>	1	Seen		Targeted	
3/1/2022	1	Shorebird Survey	JW1621	NA	NA	SE.04	1.40724803	103.977123	NA	1425	<i>Halimetus leucogaster</i>	1	Seen		Targeted	SS - can check if the spelling is correct?
3/1/2022	1	Shorebird Survey	JW1621	NA	NA	SE.04	1.40724803	103.977123	NA	1440	<i>Actitis hypoleucos</i>	1	Seen		Targeted	Incidental, perched on tallied rain tree and flew off
3/1/2022	1	Shorebird Survey	JW1621	NA	NA	SE.04	1.40724803	103.977123	NA	1448	<i>Halimetus leucogaster</i>	1	Seen		Targeted	Incidental, along coast
3/1/2022	1	Shorebird Survey	JW1621	NA	NA	SE.04	1.40724803	103.977123	NA	1455	<i>Actitis hypoleucos</i>	1	Seen		Targeted	Incidental, likely same individual as map ref. 1. flew and perched again on tallied rain tree, no rest observed though
3/1/2022	1	Shorebird Survey	JW1621	NA	NA	SE.04	1.40724803	103.977123	NA	1455	<i>Actitis hypoleucos</i>	1	Seen		Targeted	Incidental, foraging along coast, caught and ate fish at 1506h. 1546h
3/1/2022	1	Shorebird Survey	JW1621	NA	NA	SE.04	1.40724803	103.977123	NA	1518	<i>Actitis hypoleucos</i>	1	Seen		Targeted	Incidental, foraging on fir seawall
3/1/2022	1	Shorebird Survey	JW1621	NA	NA	SE.04	1.40724803	103.977123	NA	1528	<i>Actitis hypoleucos</i>	1	Seen		Targeted	Incidental, along coast
3/2/2022	2	Shorebird Survey	HB0318	1.4105	103.97865	SE.03	1.4105	103.97865	NA	1460	<i>Raphanus sativus</i>	1	Seen		Targeted	Incidental, ID to be confirmed
3/2/2022	2	Shorebird Survey	JW1622	1.410404993	103.978846	NA	NA	NA	NA	1572	<i>Brachybia chalybea</i>	1	Seen		Targeted	Incidental, ID to be confirmed
3/2/2022	2	Shorebird Survey	JW1624	1.409626985	103.978814	NA	NA	NA	NA	1351	<i>Amaurhan phidippus phidippus</i>	1	Seen		Targeted	Incidental
3/1/2022	2	Mudflat survey	NA	NA	NA	MF01	1.407360015	103.976599	2	1345-1800	<i>Cenithus corallium</i>	39	Seen		Targeted	
3/1/2022	2	Mudflat survey	NA	NA	NA	MF01	1.407360015	103.976599	2	1345-1800	<i>Centropus viridis</i>	1	Seen		Targeted	
3/1/2022	2	Mudflat survey	NA	NA	NA	MF01	1.407360015	103.976599	2	1345-1800	<i>Centropus viridis</i>	1	Seen		Targeted	
3/1/2022	2	Mudflat survey	NA	NA	NA	MF01	1.407360015	103.976599	2	1345-1800	<i>Centropus viridis</i>	1	Seen		Targeted	
3/1/2022	2	Mudflat survey	NA	NA	NA	MF01	1.407360015	103.976599	2	1345-1800	<i>Centropus viridis</i>	1	Seen		Targeted	
3/1/2022	2	Mudflat survey	NA	NA	NA	MF01	1.407360015	103.976599	2	1345-1800	<i>Centropus viridis</i>	1	Seen		Targeted	
3/1/2022	2	Mudflat survey	NA	NA	NA	MF01	1.407360015	103.976599	2	1345-1800	<i>Centropus viridis</i>	1	Seen		Targeted	
3/1/2022	2	Mudflat survey	NA	NA	NA	MF01	1.407360015	103.976599	2	1345-1800	<i>Centropus viridis</i>	1	Seen		Targeted	
3/1/2022	2	Mudflat survey	NA	NA	NA	MF01	1.407360015	103.976599	2	1345-1800	<i>Centropus viridis</i>	1	Seen		Targeted	
3/1/2022	2	Mudflat survey	NA	NA	NA	MF01	1.407360015	103.976599	2	1345-1800	<i>Centropus viridis</i>	1	Seen		Targeted	
3/1/2022	2	Mudflat survey	NA	NA	NA	MF01	1.407360015	103.976599	2	1345-1800	<i>Centropus viridis</i>	1	Seen		Targeted	
3/1/2022	2	Mudflat survey	NA	NA	NA	MF01	1.407360015	103.976599	2	1345-1800	<i>Centropus viridis</i>	1	Seen		Targeted	
3/1/2022	2	Mudflat survey	NA	NA	NA	MF01	1.407360015	103.976599	2	1345-1800	<i>Centropus viridis</i>	1	Seen		Targeted	
3/1/2022	2	Mudflat survey	NA	NA	NA	MF01	1.407360015	103.976599	2	1345-1800	<i>Centropus viridis</i>	1	Seen		Targeted	
3/1/2022	2	Mudflat survey	NA	NA	NA	MF01	1.407360015	103.976599	2	1345-1800	<i>Centropus viridis</i>	1	Seen		Targeted	
3/1/2022	2	Mudflat survey	NA	NA	NA	MF01	1.407360015	103.976599	2	1345-1800	<i>Centropus viridis</i>	1	Seen		Targeted	
3/1/2022	2	Mudflat survey	NA	NA	NA	MF01	1.407360015	103.976599	2	1345-1800	<i>Centropus viridis</i>	1	Seen		Targeted	
3/1/2022	2	Mudflat survey	NA	NA	NA	MF01	1.407360015	103.976599	2	1345-1800	<i>Centropus viridis</i>	1	Seen		Targeted	
3/1/2022	2	Mudflat survey	NA	NA	NA	MF01	1.407360015	103.976599	2	1345-1800	<i>Centropus viridis</i>	1	Seen		Targeted	
3/1/2022	2	Mudflat survey	NA	NA	NA	MF01	1.407360015	103.976599	2	1345-1800	<i>Centropus viridis</i>	1	Seen		Targeted	
3/1/2022	2	Mudflat survey	NA	NA	NA	MF01	1.407360015	103.976599	2	1345-1800	<i>Centropus viridis</i>	1	Seen		Targeted	
3/1/2022	2	Mudflat survey	NA	NA	NA	MF01	1.407360015	103.976599	2	1345-1800	<i>Centropus viridis</i>	1	Seen		Targeted	
3/1/2022	2	Mudflat survey	NA	NA	NA	MF01	1.407360015	103.976599	2	1345-1800	<i>Centropus viridis</i>	1	Seen		Targeted	
3/1/2022	2	Mudflat survey	NA	NA	NA	MF01	1.407360015	103.976599	2	1345-1800	<i>Centropus viridis</i>	1	Seen		Targeted	
3/1/2022	2	Mudflat survey	NA	NA	NA	MF01	1.407360015	103.976599	2	1345-1800	<i>Centropus viridis</i>	1	Seen		Targeted	
3/1/2022	2	Mudflat survey	NA	NA	NA	MF01	1.407360015	103.976599	2	1345-1800	<i>Centropus viridis</i>	1	Seen		Targeted	
3/1/2022	2	Mudflat survey	NA	NA	NA	MF01	1.407360015	103.976599	2	1345-1800	<i>Centropus viridis</i>	1	Seen		Targeted	
3/1/2022	2	Mudflat survey	NA	NA	NA	MF01	1.407360015	103.976599	2	1345-1800	<i>Centropus viridis</i>	1	Seen		Targeted	
3/1/2022	2	Mudflat survey	NA	NA	NA	MF01	1.407360015	103.976599	2	1345-1800	<i>Centropus viridis</i>	1	Seen		Targeted	
3/1/2022	2	Mudflat survey	NA	NA	NA	MF01	1.407360015	103.976599	2	1345-1800	<i>Centropus viridis</i>	1	Seen		Targeted	
3/1/2022	2	Mudflat survey	NA	NA	NA	MF01	1.407360015	103.976599	2	1345-1800	<i>Centropus viridis</i>	1	Seen		Targeted	
3/1/2022	2	Mudflat survey	NA	NA	NA	MF01	1.407360015	103.976599	2	1345-1800	<i>Centropus viridis</i>	1	Seen		Targeted	
3/1/2022	2	Mudflat survey	NA	NA	NA	MF01	1.407360015	103.976599	2	1345-1800	<i>Centropus viridis</i>	1	Seen		Targeted	
3/1/2022	2	Mudflat survey	NA	NA	NA	MF01	1.407360015	103.976599	2	1345-1800	<i>Centropus viridis</i>	1	Seen		Targeted	
3/1/2022	2	Mudflat survey	NA	NA	NA	MF01	1.407360015	103.976599	2	1345-1800	<i>Centropus viridis</i>	1	Seen		Targeted	
3/1/2022	2	Mudflat survey	NA	NA	NA	MF01	1.407360015	103.976599	2	1345-1800	<i>Centropus viridis</i>	1	Seen		Targeted	
3/1/2022	2	Mudflat survey	NA	NA	NA	MF01	1.407360015	103.976599	2	1345-1800	<i>Centropus viridis</i>	1	Seen		Targeted	
3/1/2022	2	Mudflat survey	NA	NA	NA	MF01	1.407360015	103.976599	2	1345-1800	<i>Centropus viridis</i>	1	Seen		Targeted	
3/1/2022	2	Mudflat survey	NA	NA	NA	MF01	1.407360015	103.976599	2	1345-1800	<i>Centropus viridis</i>	1	Seen		Targeted	
3/1/2022	2	Mudflat survey	NA	NA	NA	MF01	1.407360015	103.976599	2	1345-1800	<i>Centropus viridis</i>	1	Seen		Targeted	
3/1/2022	2	Mudflat survey	NA	NA	NA	MF01	1.407360015	103.976599	2	1345-1800	<i>Centropus viridis</i>	1	Seen		Targeted	
3/1/2022	2	Mudflat survey	NA	NA	NA	MF01	1.407360015	103.976599	2	1345-1800	<i>Centropus viridis</i>	1	Seen		Targeted	
3/1/2022	2	Mudflat survey	NA	NA	NA	MF01	1.407360015	103.976599	2	1345-1800	<i>Centropus viridis</i>	1	Seen		Targeted	
3/1/2022	2	Mudflat survey	NA	NA	NA	MF01	1.407360015	103.976599	2	1345-1800	<i>Centropus viridis</i>	1	Seen		Targeted	
3/1/2022	2	Mudflat survey	NA	NA	NA	MF01	1.407360015	103.976599	2	1345-1800	<i>Centropus viridis</i>	1	Seen		Targeted	
3/1/2022	2	Mudflat survey	NA	NA	NA	MF01	1.407360015	103.976599	2	1345-1800	<i>Centropus viridis</i>	1	Seen		Targeted	
3/1/2022	2	Mudflat survey	NA	NA	NA	MF01	1.407360015	103.976599	2	1345-1800	<i>Centropus viridis</i>	1	Seen		Targeted	
3/1/2022	2	Mudflat survey	NA	NA	NA	MF01	1.407360015	103.976599	2	1345-1800	<i>Centropus viridis</i>	1	Seen		Targeted	
3/1/2022	2	Mudflat survey	NA	NA	NA	MF01	1.407360015	103.976599	2	1345-1800	<i>Centropus viridis</i>	1	Seen		Targeted	
3/1/2022	2	Mudflat survey	NA	NA	NA	MF01	1.407360015	103.976599	2	1345-1800	<i>Centropus viridis</i>	1	Seen		Targeted	
3/1/2022	2	Mudflat survey	NA	NA	NA	MF01	1.407360015	103.976599	2	1345-1800	<i>Centropus viridis</i>	1	Seen		Targeted	
3/1/2022	2	Mudflat survey	NA	NA	NA	MF01	1.407360015	103.976599	2	1345-1800	<i>Centropus viridis</i>	1	Seen		Targeted	
3/1/2022	2	Mudflat survey	NA	NA	NA	MF01	1.407360015	103.976599	2	1345-1800	<i>Centropus viridis</i>	1	Seen		Targeted	
3/1/2022	2	Mudflat survey	NA	NA	NA	MF01	1.407360015	103.976599	2	1345-1800	<i>Centropus viridis</i>	1	Seen			

Date	Cycle	Route	Waypoint	Latitude	Longitude	Sampling point	Latitude	Longitude	Quadrat	Time (24h)	Scientific name	Quantity	Observation type (seen/heard/caught/other signs)	Photo no.	Survey method (targeted/incidental/point count/trapping)	Remarks
3/1/2022	2	T1	7836	1.408617971	103.978143	NA	NA	NA	NA	2104	<i>Paradousaurus musangus</i>	1	Seen		Targeted	Poop
3/1/2022	2	T1	7837	1.40870258	103.979494	NA	NA	NA	NA	2106	<i>Fegurvaria cancrivora</i>	2	Seen	Z10281-2808	Targeted	
3/1/2022	2	T1	7838	1.408713022	103.979386	NA	NA	NA	NA	2109	<i>Tropidus naxos</i>	1	Seen	Z10270	Targeted	
3/1/2022	2	T1	7839	1.408726978	103.979583	NA	NA	NA	NA	2109	<i>Dulligaprymus melanostictus</i>	1	Seen		Targeted	
3/1/2022	2	T1	7840	1.408811007	103.979570	NA	NA	NA	NA	2116	<i>Dulligaprymus melanostictus</i>	1	Seen		Targeted	
3/1/2022	2	T1	7841	1.408831981	103.979526	NA	NA	NA	NA	2127	Unidentified Gekkonidae	1	Seen		Targeted	
3/1/2022	2	T1	7841	1.408331981	103.979526	NA	NA	NA	NA	2127	<i>Polypedates leucomystax</i>	1	Heard		Targeted	
3/1/2022	2	T1	7841	1.408331981	103.979526	NA	NA	NA	NA	2127	<i>Sus scrofa</i>	1	Seen		Targeted	
3/1/2022	2	T1	7844	1.408142969	103.979229	NA	NA	NA	NA	2129	<i>Polypedates leucomystax</i>	1	Heard		Targeted	
3/1/2022	2	T1	7843	1.407990117	103.979766	NA	NA	NA	NA	2140	<i>Fegurvaria cancrivora</i>	1	Seen	Z10275-2876	Targeted	
3/1/2022	2	T1	7844	1.407791977	103.979319	NA	NA	NA	NA	2145	<i>Eublepharis cf. varicolor</i>	1	Seen	Z17118, 121, 1324	Incidental	Photo missing
3/1/2022	2	T1	7845	1.407972968	103.979325	NA	NA	NA	NA	2145	<i>Hemirhamphys</i>	1	Seen		Targeted	
3/1/2022	2	T1	7846	1.408062	103.979119	NA	NA	NA	NA	2145	<i>Fegurvaria cancrivora</i>	1	Seen	Z10277-2880	Targeted	
3/1/2022	2	T1	7846	1.408062	103.979119	NA	NA	NA	NA	2145	Unidentified Gekkonidae	1	Heard		Targeted	
3/1/2022	2	T1	7847	1.408199959	103.979399	NA	NA	NA	NA	2145	<i>Fegurvaria cancrivora</i>	1	Seen		Targeted	
3/1/2022	2	T2	7849	1.408426026	103.978938	NA	NA	NA	NA	759	<i>Lutrologale perspicillata</i>	2	Seen	Z10281-2882	Targeted	one feeding
3/1/2022	2	T2	7850	1.408040111	103.979001	NA	NA	NA	NA	733	<i>Lutrologale perspicillata</i>	9	Seen	H85153-5160	Targeted	vocalizing. One feeding. All sea side
3/1/2022	2	T2	7850	1.408040111	103.979001	NA	NA	NA	NA	733	<i>Varanus salawati</i>	1	Seen		Targeted	
3/1/2022	2	T2	7850	1.408040111	103.979001	NA	NA	NA	NA	733	<i>Heria baluata</i>	2	Seen		Targeted	
3/1/2022	2	T2	7851	1.408940419	103.978917	NA	NA	NA	NA	736	<i>Anthracoeros albicinctus</i>	1	Heard		Targeted	
3/1/2022	2	T2	7851	1.408940419	103.978917	NA	NA	NA	NA	736	<i>Rhipidura javanica</i>	1	Seen		Targeted	
3/1/2022	2	T2	7852	1.408189886	103.978901	NA	NA	NA	NA	738	<i>Haliastur indus</i>	1	Seen		Targeted	
3/1/2022	2	T2	7852	1.408189886	103.978901	NA	NA	NA	NA	738	<i>Todiramphus chloris</i>	1	Heard		Targeted	
3/1/2022	2	T2	7853	1.40804995	103.978896	NA	NA	NA	NA	738	<i>Corvus splendens</i>	1	Seen		Targeted	
3/1/2022	2	T2	7853	1.40804995	103.978896	NA	NA	NA	NA	738	<i>Haliastur leucogaster</i>	1	Seen		Targeted	
3/1/2022	2	T2	7854	1.408252023	103.978893	NA	NA	NA	NA	738	<i>Agallina liphia</i>	1	Heard		Targeted	
3/1/2022	2	T2	7854	1.408252023	103.978893	NA	NA	NA	NA	738	<i>Varanus salvator</i>	1	Seen		Targeted	
3/1/2022	2	T2	7854	1.408252023	103.978893	NA	NA	NA	NA	740	<i>Aerodramus sp.</i>	2	Seen		Targeted	
3/1/2022	2	T2	7855	1.40831981	103.978885	NA	NA	NA	NA	740	<i>Dinopium javanense</i>	2	Seen		Targeted	
3/1/2022	2	T2	7856	1.40838008	103.978904	NA	NA	NA	NA	740	<i>Dendrocygna caudocinctus</i>	1	Seen	H85161-5164	Targeted	same location as previous night. Same individual
3/1/2022	2	T2	7856	1.40838008	103.978904	NA	NA	NA	NA	741	<i>Haliastur leucogaster</i>	1	Seen		Targeted	Leaving. landed on a tree.
3/1/2022	2	T2	7856	1.40838008	103.978904	NA	NA	NA	NA	743	<i>Agallina liphia</i>	1	Heard		Targeted	
3/1/2022	2	T2	7857	1.40856604	103.978835	NA	NA	NA	NA	743	<i>Orthotomus ruficeps</i>	1	Heard		Targeted	
3/1/2022	2	T2	7857	1.40856604	103.978835	NA	NA	NA	NA	743	<i>Labeo nora</i>	1	Heard		Targeted	
3/1/2022	2	T2	7858	1.40892993	103.978836	NA	NA	NA	NA	743	<i>Rhipidura javanica</i>	2	Heard		Targeted	
3/1/2022	2	T2	7858	1.40892993	103.978836	NA	NA	NA	NA	745	<i>Anthreptes malacensis</i>	1	Heard		Targeted	
3/1/2022	2	T2	7858	1.40892993	103.978836	NA	NA	NA	NA	745	<i>Orthotomus ruficeps</i>	1	Heard		Targeted	
3/1/2022	2	T2	7859	1.408811007	103.978858	NA	NA	NA	NA	748	<i>Anthracoeros albicinctus</i>	1	Seen		Targeted	
3/1/2022	2	T2	7859	1.408811007	103.978858	NA	NA	NA	NA	748	<i>Fegurvaria cancrivora</i>	1	Seen	H85167	Targeted	
3/1/2022	2	T2	7859	1.408811007	103.978858	NA	NA	NA	NA	748	<i>Haliastur leucogaster</i>	2	Seen		Targeted	
3/1/2022	2	T2	7859	1.408811007	103.978858	NA	NA	NA	NA	748	<i>Rhipidura javanica</i>	1	Heard		Targeted	
3/1/2022	2	T2	7860	1.40884982	103.978883	NA	NA	NA	NA	750	<i>Agallina liphia</i>	1	Heard		Targeted	
3/1/2022	2	T2	7863	1.40932027	103.978901	NA	NA	NA	NA	750	<i>Pycnonotus javanicus</i>	1	Heard		Targeted	
3/1/2022	2	T2	7862	1.409374019	103.978883	NA	NA	NA	NA	750	<i>Ptilinopus capensis</i>	1	Heard		Targeted	
3/1/2022	2	T2	7862	1.409374019	103.978883	NA	NA	NA	NA	750	<i>Pycnonotus javanicus</i>	2	Heard		Targeted	
3/1/2022	2	T2	7863	1.40938997	103.978833	NA	NA	NA	NA	750	<i>Copsychus saularis</i>	1	Heard		Targeted	
3/1/2022	2	T2	7864	1.40949364	103.978822	NA	NA	NA	NA	757	<i>Aerodramus sp.</i>	1	Heard		Targeted	
3/1/2022	2	T2	7865	1.40953024	103.978821	NA	NA	NA	NA	757	<i>Pycnonotus plumosus</i>	2	Heard		Targeted	
3/1/2022	2	T2	7866	1.40917017	103.97888	NA	NA	NA	NA	757	<i>Orthotomus ruficeps</i>	1	Seen		Targeted	
3/1/2022	2	T2	7866	1.40917017	103.97888	NA	NA	NA	NA	757	<i>Pycnonotus javanicus</i>	1	Seen		Targeted	
3/1/2022	2	T2	7867	1.40968042	103.978822	NA	NA	NA	NA	757	<i>Orthotomus ruficeps</i>	3	Heard		Targeted	
3/1/2022	2	T2	7868	1.40969991	103.978833	NA	NA	NA	NA	759	<i>Aethopoga sparaga</i>	1	Heard		Targeted	
3/1/2022	2	T2	7868	1.40969991	103.978833	NA	NA	NA	NA	759	<i>Aerodramus sp.</i>	2	Seen		Targeted	
3/1/2022	2	T2	7869	1.409762023	103.978818	NA	NA	NA	NA	759	<i>Dinopium javanense</i>	2	Heard		Targeted	
3/1/2022	2	T2	7870	1.41011903	103.978743	NA	NA	NA	NA	802	<i>Pycnonotus plumosus</i>	2	Seen		Targeted	
3/1/2022	2	T2	7870	1.41011903	103.978743	NA	NA	NA	NA	802	<i>Orthotomus ruficeps</i>	1	Heard		Targeted	
3/1/2022	2	T2	7870	1.41011903	103.978743	NA	NA	NA	NA	802	<i>Rhipidura javanica</i>	1	Heard		Targeted	
3/1/2022	2	T2	7871	1.41021796	103.978729	NA	NA	NA	NA	804	<i>Mergip sp.</i>	2	Heard		Targeted	
3/1/2022	2	T2	7871	1.41021796	103.978729	NA	NA	NA	NA	804	<i>Dicaeum everedii</i>	2	Heard		Targeted	
3/1/2022	2	T2	7872	1.41050489	103.978712	NA	NA	NA	NA	806	<i>Mergip philippina</i>	2	Seen		Targeted	Perched on tree canopy
3/1/2022	2	T2	7872	1.41050489	103.978712	NA	NA	NA	NA	806	<i>Anthreptes malacensis</i>	1	Heard		Targeted	
3/1/2022	2	T2	7873	1.410651002	103.978651	NA	NA	NA	NA	809	<i>Lophoceros alberti</i>	1	Heard		Targeted	
3/1/2022	2	T2	7873	1.410651002	103.978651	NA	NA	NA	NA	809	<i>Phycocopus bonalis</i>	1	Seen		Targeted	Feeding on Brugansia
3/1/2022	2	T2	7874	1.410655025	103.978697	NA	NA	NA	NA	809	<i>Haliastur leucogaster</i>	2	Seen		Targeted	Flow back, low flying
3/1/2022	2	T2	7874	1.410655025	103.978697	NA	NA	NA	NA	809	<i>Pycnonotus plumosus</i>	2	Seen		Targeted	
3/1/2022	2	T2	7874	1.410655025	103.978697	NA	NA	NA	NA	809	<i>Aerodramus sp.</i>	5	Seen		Targeted	
3/1/2022	2	T2	7874	1.410655025	103.978697	NA	NA	NA	NA	813	<i>Copsychus saularis</i>	1	Heard		Targeted	
3/1/2022	2	T2	7874	1.410655025	103.978697	NA	NA	NA	NA	813	<i>Trogon vernans</i>	1	Seen		Targeted	
3/1/2022	2	T2	7875	1.410656031	103.978456	NA	NA	NA	NA	813	<i>Trogon vernans</i>	1	Seen		Targeted	
3/1/2022	2	T2	7875	1.410656031	103.978456	NA	NA	NA	NA	814	<i>Aethopoga sparaga</i>	1	Heard		Targeted	
3/1/2022	2	T2	7876	1.41087985	103.978399	NA	NA	NA	NA	816	<i>Dicaeum everedii</i>	2	Heard		Targeted	Building a nest?
3/1/2022	2	T2	7877	1.41087996	103.978314	NA	NA	NA	NA	816	<i>Agallina liphia</i>	1	Heard		Targeted	
3/1/2022	2	T2	7877	1.41087996	103.978314	NA	NA	NA	NA	816	<i>Pycnonotus plumosus</i>	1	Heard		Targeted	Feeding on flous tree
3/1/2022	2	T2	7877	1.41087996	10											

Date	Cycle	Route	Waypoint	Latitude	Longitude	Sampling point	Latitude	Longitude	Quadrat	Time (24h)	Scientific name	Quantity	Observation type (seen/heard/caught/other signs)	Photo no.	Survey method (targeted/incidental/point count/trapping)	Remarks
3/2/2022	2	T1	Z7898	1.40884013	103.976566	NA	NA	NA	NA	918	<i>Orthotomus albigularis</i>	1	Heard		Targeted	
3/2/2022	2	T1	Z7898	1.40884013	103.976566	NA	NA	NA	NA	918	<i>Scopelogadus</i>	1	Heard		Targeted	
3/2/2022	2	T1	Z7898	1.40884013	103.976566	NA	NA	NA	NA	918	<i>Acridotheres javanicus</i>	2	Heard		Targeted	
3/2/2022	2	T1	Z7899	1.40862009	103.976526	NA	NA	NA	NA	920	<i>Copsychus malabaricus</i>	1	Heard		Targeted	
3/2/2022	2	T1	Z7900	1.40863996	103.976687	NA	NA	NA	NA	922	<i>Antrypopsis malacensis</i>	1	Heard		Targeted	
3/2/2022	2	T1	Z7901	1.40863996	103.976687	NA	NA	NA	NA	922	<i>Orthotomus ruficeps</i>	1	Heard		Targeted	
3/2/2022	2	T1	Z7901	1.40869778	103.975995	NA	NA	NA	NA	923	<i>Pycnonotus plumbeus</i>	1	Heard		Targeted	
3/2/2022	2	T1	Z7902	1.40873989	103.975122	NA	NA	NA	NA	926	<i>Copsychus malabaricus</i>	1	Seen		Targeted	
3/2/2022	2	T1	Z7903	1.40855523	103.975494	NA	NA	NA	NA	929	<i>Pliciscus caudatus</i>	1	Heard		Targeted	
3/2/2022	2	T1	Z7903	1.40855523	103.975494	NA	NA	NA	NA	929	<i>Halimastur leucogaster</i>	2	Seen		Targeted	
3/2/2022	2	T1	Z7903	1.40855523	103.975494	NA	NA	NA	NA	929	<i>Copsychus malabaricus</i>	1	Seen		Targeted	
3/2/2022	2	T1	Z7903	1.40855523	103.975494	NA	NA	NA	NA	929	<i>Pycnonotus plumbeus</i>	1	Heard		Targeted	
3/2/2022	2	T1	Z7903	1.40855523	103.975494	NA	NA	NA	NA	929	<i>Ficedula zanthopygia</i>	1	Heard		Targeted	
3/2/2022	2	T1	Z7904	1.40811204	103.975625	NA	NA	NA	NA	929	<i>Arundinaceae</i> sp.	4	Seen		Targeted	
3/2/2022	2	T1	Z7904	1.40811204	103.975625	NA	NA	NA	NA	929	<i>Dactylopsitta melanoleuca</i>	1	Heard		Targeted	Tadpoles
3/2/2022	2	T1	Z7904	1.40811204	103.975625	NA	NA	NA	NA	929	<i>Copsychus saularis</i>	1	Heard		Targeted	
3/2/2022	2	T1	Z7905	1.40799782	103.975601	NA	NA	NA	NA	935	<i>Pycnonotus javanicus</i>	1	Heard		Targeted	
3/2/2022	2	T1	Z7905	1.40799782	103.975601	NA	NA	NA	NA	935	<i>Copsychus saularis</i>	1	Heard		Targeted	
3/2/2022	2	T1	Z7906	1.40794594	103.975758	NA	NA	NA	NA	937	<i>Rhipidura javanica</i>	1	Heard		Targeted	
3/2/2022	2	T1	Z7907	1.40787076	103.975799	NA	NA	NA	NA	938	<i>Aplonis panayensis</i>	1	Heard		Targeted	
3/2/2022	2	T1	Z7907	1.40787076	103.975799	NA	NA	NA	NA	938	<i>Troglodytes chloris</i>	1	Heard		Targeted	
3/2/2022	2	T1	Z7908	1.40782008	103.975798	NA	NA	NA	NA	939	<i>Antrypopsis malacensis</i>	1	Heard		Targeted	
3/2/2022	2	T1	Z7908	1.40782008	103.975798	NA	NA	NA	NA	939	<i>Vireon verreauxi</i>	1	Seen		Targeted	
3/2/2022	2	T1	Z7908	1.40782008	103.975798	NA	NA	NA	NA	941	<i>Antrypopsis malacensis</i>	1	Heard		Targeted	
3/2/2022	2	T1	Z7909	1.40762785	103.975882	NA	NA	NA	NA	941	<i>Rhipidura javanica</i>	1	Heard		Targeted	
3/2/2022	2	T1	Z7909	1.40762785	103.975882	NA	NA	NA	NA	941	<i>Halimastur leucogaster</i>	1	Seen		Targeted	
3/2/2022	2	T1	Z7909	1.40762785	103.975882	NA	NA	NA	NA	941	<i>Arundinaceae</i> sp.	1	Heard		Targeted	
3/2/2022	2	T1	Z7909	1.40762785	103.975882	NA	NA	NA	NA	941	<i>Halimastur indus</i>	1	Seen		Targeted	
3/2/2022	2	T1	Z7909	1.40762785	103.975882	NA	NA	NA	NA	941	<i>Orthotomus ruficeps</i>	2	Heard		Targeted	
3/2/2022	2	T1	Z7909	1.40762785	103.975882	NA	NA	NA	NA	941	<i>Pinus polystrobilata</i>	1	Heard		Targeted	
3/2/2022	2	T1	Z7910	1.40821787	103.975759	NA	NA	NA	NA	941	<i>Attopogon siorapala</i>	1	Heard		Targeted	
2/16/2022	1	Mudflat survey	NA	NA	NA	MF09	1.40997607	103.978305	5	1630-1800	<i>Optoceros brevicaudus</i>	2	Seen		Targeted	<i>Optoceros brevicaudus</i> is taxonomically correct name
2/16/2022	1	Mudflat survey	NA	NA	NA	MF09	1.40997607	103.978305	NA	1630-1800	<i>Phenacanthus</i> sp.	1	Seen	Z10299-0301	Incidental	
2/16/2022	1	Mudflat survey	NA	NA	NA	MF09	1.40997607	103.978305	NA	1630-1800	<i>Meliponae elegans</i>	1	Seen	Z10295-0297	Incidental	Female? to be confirmed
2/16/2022	1	Mudflat survey	NA	NA	NA	MF09	1.40997607	103.978305	NA	1630-1800	<i>Chloroceryle leucophaea</i>	2	Seen		Incidental	
2/16/2022	1	Mudflat survey	NA	NA	NA	MF09	1.40997607	103.978305	NA	1630-1800	<i>Halcyon leucostriata</i>	1	Seen	Z10268-0276	Incidental	
2/16/2022	1	Mudflat survey	NA	NA	NA	MF09	1.40997607	103.978305	5	1630-1800	<i>Pternella cinquata</i>	5	Seen	Z10738-0740	Targeted	
2/16/2022	1	Mudflat survey	NA	NA	NA	MF09	1.40997607	103.978305	5	1630-1800	Family Ostridae	1	Seen	DS000792_Family Ostridae	Targeted	On P. alata shell
2/16/2022	1	Mudflat survey	NA	NA	NA	MF09	1.40997607	103.978305	5	1630-1800	<i>Pternella cinquata</i>	5	Seen	Z10643-0644	Targeted	
2/16/2022	1	Mudflat survey	NA	NA	NA	MF09	1.40997607	103.978305	5	1630-1800	<i>Gobelia coarctata</i>	3	Seen	Z10741-0743	Targeted	
2/16/2022	1	Mudflat survey	NA	NA	NA	MF09	1.40997607	103.978305	5	1630-1800	<i>Placamen chinofurium</i>	1	Seen	Z10744-0746	Targeted	
2/16/2022	1	Mudflat survey	NA	NA	NA	MF09	1.40997607	103.978305	10	1630-1800	<i>Optoceros brevicaudus</i>	10	Seen		Targeted	
2/16/2022	1	Mudflat survey	NA	NA	NA	MF09	1.40997607	103.978305	15	1630-1800	<i>Optoceros brevicaudus</i>	5	Seen		Targeted	
2/16/2022	1	Mudflat survey	NA	NA	NA	MF09	1.40997607	103.978305	15	1630-1800	<i>Marcia hiantina</i>	10	Seen	P1600283_Marcia hiantina	Targeted	
2/16/2022	1	Mudflat survey	NA	NA	NA	MF09	1.40997607	103.978305	10	1630-1800	<i>Pternella cinquata</i>	5	Seen		Targeted	
2/16/2022	1	Mudflat survey	NA	NA	NA	MF09	1.40997607	103.978305	15	1630-1800	<i>Cerithium corallium</i>	1	Seen	P1600277_Cerithium corallium and Pternella cinquata	Targeted	
2/16/2022	1	Mudflat survey	NA	NA	NA	MF09	1.40997607	103.978305	10	1630-1800	<i>Ptilor</i> sp.	1	Seen	Z10729	Targeted	
2/16/2022	1	Mudflat survey	NA	NA	NA	MF09	1.40997607	103.978305	10	1630-1800	<i>Telostomatia telescopium</i>	1	Seen	Z10729	Targeted	
2/16/2022	1	Mudflat survey	NA	NA	NA	MF09	1.40997607	103.978305	10	1630-1800	<i>Littoridin</i> sp.	1	Seen	P1600209_Littoridin sp.	Targeted	
2/16/2022	1	Mudflat survey	NA	NA	NA	MF09	1.40997607	103.978305	15	1630-1800	<i>Pternella</i> sp.	2	Seen		Targeted	
2/16/2022	1	Mudflat survey	NA	NA	NA	MF09	1.40997607	103.978305	15	1630-1800	<i>Telostomatia telescopium</i>	1	Seen		Targeted	
2/16/2022	1	Mudflat survey	NA	NA	NA	MF09	1.40997607	103.978305	15	1630-1800	<i>Marcia</i> sp.	1	Seen	Z10310-0311	Targeted	
2/16/2022	1	Mudflat survey	NA	NA	NA	MF09	1.40997607	103.978305	NA	1630-1800	<i>Carinocerosus rotundicauda</i>	1	Seen	Z10312-0316	Incidental	
3/1/2022	1	Mudflat survey	NA	NA	NA	MF02	1.41087899	103.979236	5	1345-1800	<i>Optoceros brevicaudus</i>	2	Seen	Z10610-0619	Targeted	Lots of mud lobster mounts at this site
3/1/2022	1	Mudflat survey	NA	NA	NA	MF02	1.41087899	103.979236	10	1345-1800	<i>Gobelia</i> sp.	1	Seen	Z10645-0647	Targeted	Just, very hard to determine the difference between G. coarctata and G. expansa
3/1/2022	1	Mudflat survey	NA	NA	NA	MF02	1.41087899	103.979236	10	1345-1800	<i>Undulidifera garipany nympha</i>	1	Seen	Z10635	Targeted	Burly photo
3/1/2022	1	Mudflat survey	NA	NA	NA	MF02	1.41087899	103.979236	10	1345-1800	Family Scissaridae	1	Seen	Z10626-0627	Targeted	
3/1/2022	1	Mudflat survey	NA	NA	NA	MF02	1.41087899	103.979236	10	1345-1800	<i>Melipotis subulata</i>	1	Seen	Z10628	Targeted	
3/1/2022	1	Mudflat survey	NA	NA	NA	MF02	1.41087899	103.979236	10	1345-1800	<i>Gobelia coarctata</i>	4	Seen	Z10641	Targeted	
3/1/2022	1	Mudflat survey	NA	NA	NA	MF02	1.41087899	103.979236	15	1345-1800	<i>Gobelia coarctata</i>	6	Seen		Targeted	
3/1/2022	1	Mudflat survey	NA	NA	NA	MF02	1.41087899	103.979236	5	1345-1800	<i>Gobelia coarctata</i>	5	Seen	DS000606	Targeted	
3/1/2022	1	Mudflat survey	NA	NA	NA	MF02	1.41087899	103.979236	10	1345-1800	Quadrat	NA	Seen		Targeted	NA
3/1/2022	1	Mudflat survey	NA	NA	NA	MF02	1.41087899	103.979236	15	1345-1800	Quadrat	NA	Seen	DS000638	Targeted	NA
3/1/2022	1	Mudflat survey	NA	NA	NA	MF02	1.41087899	103.979236	10	1345-1800	<i>Optoceros brevicaudus</i>	1	Seen		Targeted	
3/1/2022	1	Mudflat survey	NA	NA	NA	MF02	1.41087899	103.979236	10	1345-1800	<i>Phenacanthus waldakae</i>	1	Seen	DS000637_Phenacanthus waldakae	Incidental	
3/1/2022	1	Mudflat survey	NA	NA	NA	MF02	1.41087899	103.979236	NA	1345-1800	<i>Dermogarys collettii</i>	3	Seen		Incidental	
3/1/2022	2	Mudflat survey	NA	NA	NA	MF03	1.40820495	103.976679	0	1345-1800	Quadrat	NA	Seen	0m	Targeted	
3/1/2022	2	Mudflat survey	NA	NA	NA	MF03	1.40820495	103.976679	0	1345-1800	<i>Pternella alata</i>	150	Seen		Targeted	
3/1/2022	2	Mudflat survey	NA	NA	NA	MF03	1.40820495	103.976679	0	1345-1800	<i>Optoceros brevicaudus</i>	2	Seen	Z10733-0734	Targeted	dead
3/1/2022	2	Mudflat survey	NA	NA	NA	MF03	1.40820495	103.976679	0	1345-1800	<i>Gobelia expansa</i>	1	Seen	Z10709	Targeted	
3/1/2022	2	Mudflat survey	NA	NA	NA	MF03	1.40820495	103.976679	0	1345-1800	<i>Dipodops</i> sp.	3	Seen	Z10711_0714-0715	Targeted	Clockwise from top left, 3 and 5: SS to ID to species
3/1/2022	2	Mudflat survey	NA	NA	NA	MF03	1.40820495	103.976679	0	1345-1800	<i>Dentaria</i> sp.	3	Seen	Z10711	Targeted	Clockwise from top left, 1, 2 and 4
3/1/2022	2	Mudflat survey	NA	NA	NA	MF03	1.40820495	103.976679	0	1345-1800	<i>Marcia japonica</i>	1	Seen	Z10715-0717	Targeted	
3/1/2022	2	Mudflat survey	NA	NA	NA	MF03	1.40820495	103.976679	0	1345-1800	<i>Placamen chinofurium</i>	2	Seen		Targeted	
3/1/2022	2	Mudflat survey	NA	NA	NA	MF03	1.40820495	103.976679	0	1345-1800	<i>Berberia</i> sp.	1	Seen	Z10713-0722	Targeted	
3/1/2022	2	Mudflat survey	NA	NA	NA	MF03	1.40820495	103.976679	0	1345-1800	Family Ferredae	1	Seen	Z10718	Targeted	
3/1/2022	2	Mudflat survey	NA	NA	NA	MF03	1.40820495	103.976679	0	1345-1800	<i>Nasarius jacksonianus</i>	2	Seen	Z10719-0720	Targeted	
3/1/2022	2	Mudflat survey	NA	NA	NA	MF03	1.40820495	103.976679	0	1345-1800	<i>Orania dimorpha</i>	1	Seen	Z10721-0722	Targeted	
3/1/2022	2	Mudflat survey	NA	NA	NA	MF03	1.40820495	103.976679	0	1345-1800	<i>Indolops gradatus</i>	1	Seen	Z10723-0725		

Date	Cycle	Route	Waypoint	Latitude	Longitude	Sampling point	Latitude	Longitude	Quadrat	Time (24h)	Scientific name	Quantity	Observation type (seen/heard/caught/sat/other signs)	Photo no.	Survey method (targeted/incidental/point count/trapping)	Remarks
3/2/2022	1	Mudflat survey	NA	NA	NA	MF05	1.40796013	103.978653	0	1415-1715	<i>Cerithium corallium</i>	1	Seen		Targeted	
3/2/2022	1	Mudflat survey	NA	NA	NA	MF05	1.40796013	103.978653	0	1415-1715	<i>Pireneia astor</i>	1	Seen	DS000751_Pireneia astor	Targeted	
3/2/2022	1	Mudflat survey	NA	NA	NA	MF05	1.40796013	103.978653	0	1415-1715	<i>Arctostaphylos</i>	32	Seen	270749-0755	Targeted	
3/2/2022	1	Mudflat survey	NA	NA	NA	MF05	1.40796013	103.978653	0	1415-1715	<i>Pireneia cingulata</i>	1	Seen	DS000748_Cerithium corallium Pireneia cingulata	Targeted	
3/2/2022	1	Mudflat survey	NA	NA	NA	MF05	1.40796013	103.978653	0	1415-1715	<i>Pireneia micropora</i>	1	Seen		Targeted	
3/2/2022	1	Mudflat survey	NA	NA	NA	MF05	1.40796013	103.978653	0	1415-1715	<i>Andaria antiquata</i>	1	Seen	DS000760_Andaria antiquata	Targeted	
3/2/2022	1	Mudflat survey	NA	NA	NA	MF05	1.40796013	103.978653	0	1415-1715	<i>Donnia sp.</i>	1	Seen	DS000761_Donia sp.	Targeted	
3/2/2022	1	Mudflat survey	NA	NA	NA	MF05	1.40796013	103.978653	0	1415-1715	<i>Andaria antiquata</i>	1	Seen	DS000756_Andaria antiquata	Targeted	
3/2/2022	1	Mudflat survey	NA	NA	NA	MF05	1.40796013	103.978653	0	1415-1715	<i>Donnia sp.</i>	1	Seen	DS000761_Donia sp.	Targeted	
3/2/2022	1	Mudflat survey	NA	NA	NA	MF05	1.40796013	103.978653	0	1415-1715	<i>Circo scripta</i>	1	Seen	DS000765_Circo scripta	Targeted	
3/2/2022	1	Mudflat survey	NA	NA	NA	MF05	1.40796013	103.978653	0	1415-1715	<i>Serratina sp.</i>	1	Seen	DS000768_Serratina sp.	Targeted	
3/2/2022	1	Mudflat survey	NA	NA	NA	MF05	1.40796013	103.978653	0	1415-1715	<i>Trochana nodifera</i>	1	Seen	Z70747-0750	Targeted	
3/2/2022	1	Mudflat survey	NA	NA	NA	MF05	1.40796013	103.978653	0	1415-1715	<i>Gobiosoma coxianum</i>	1	Seen	Z70761	Targeted	
3/2/2022	1	Mudflat survey	NA	NA	NA	MF05	1.40796013	103.978653	0	1415-1715	<i>Anomolobius squamosus</i>	10	Seen	Z70762-0764	Targeted	
3/2/2022	1	Mudflat survey	NA	NA	NA	MF05	1.40796013	103.978653	0	1415-1715	<i>Nassarius stolidus</i>	1	Seen	DS000771_Nassarius stolidus	Targeted	
3/2/2022	1	Mudflat survey	NA	NA	NA	MF05	1.40796013	103.978653	0	1415-1715	<i>Orania bimacronata</i>	1	Seen	DS000780_Orania bimacronata	Targeted	
3/2/2022	1	Mudflat survey	NA	NA	NA	MF05	1.40796013	103.978653	0	1415-1715	<i>Nassarius stolidus</i>	1	Seen	DS000771_Nassarius stolidus	Targeted	
3/2/2022	1	Mudflat survey	NA	NA	NA	MF05	1.40796013	103.978653	0	1415-1715	<i>Nassarius stolidus</i>	1	Seen	DS000771_Nassarius stolidus	Targeted	
3/2/2022	1	Mudflat survey	NA	NA	NA	MF05	1.40796013	103.978653	0	1415-1715	<i>Nassarius fluviens</i>	4	Seen	Z70770-0772	Targeted	
3/2/2022	1	Mudflat survey	NA	NA	NA	MF05	1.40796013	103.978653	0	1415-1715	<i>Strophomena</i>	1	Seen	Z70773-0776	Targeted	
3/2/2022	1	Mudflat survey	NA	NA	NA	MF05	1.40796013	103.978653	0	1415-1715	<i>Isaiaea bombyxiana</i>	1	Seen	Z70771-0779	Targeted	
3/2/2022	1	Mudflat survey	NA	NA	NA	MF05	1.40796013	103.978653	5	1415-1715	<i>Placamen chitoniforme</i>	6	Seen		Targeted	
3/2/2022	1	Mudflat survey	NA	NA	NA	MF05	1.40796013	103.978653	5	1415-1715	<i>Chitonimorphus gracilis</i>	NA	Seen	DS000783_Chitonimorphus gracilis	Targeted	
3/2/2022	1	Mudflat survey	NA	NA	NA	MF05	1.40796013	103.978653	5	1415-1715	<i>Ulva sp.</i>	1	Seen	Z70781	Targeted	
3/2/2022	1	Mudflat survey	NA	NA	NA	MF05	1.40796013	103.978653	5	1415-1715	<i>Chitonimorphus sp.</i>	2	Seen		Targeted	
3/2/2022	1	Mudflat survey	NA	NA	NA	MF05	1.40796013	103.978653	5	1415-1715	<i>Family Ostreidae</i>	2	Seen		Targeted	
3/2/2022	1	Mudflat survey	NA	NA	NA	MF05	1.40796013	103.978653	5	1415-1715	<i>Anomolobius squamosus</i>	49	Seen	Z70788	Targeted	
3/2/2022	1	Mudflat survey	NA	NA	NA	MF05	1.40796013	103.978653	5	1415-1715	<i>Perna viridis</i>	1	Seen	Z70789	Targeted	
3/2/2022	1	Mudflat survey	NA	NA	NA	MF05	1.40796013	103.978653	5	1415-1715	<i>Bastardia zonaria</i>	37	Seen	Z70789	Targeted	
3/2/2022	1	Mudflat survey	NA	NA	NA	MF05	1.40796013	103.978653	5	1415-1715	<i>Aethya arctica</i>	5	Seen	Z70790	Targeted	
3/2/2022	1	Mudflat survey	NA	NA	NA	MF05	1.40796013	103.978653	5	1415-1715	<i>Serratina sp.</i>	2	Seen	Z70792_0797	Targeted	
3/2/2022	1	Mudflat survey	NA	NA	NA	MF05	1.40796013	103.978653	5	1415-1715	<i>Nassarius stolidus</i>	1	Seen	Z70794	Targeted	
3/2/2022	1	Mudflat survey	NA	NA	NA	MF05	1.40796013	103.978653	5	1415-1715	<i>Family Arcaidae</i>	1	Seen	Z70793	Targeted	
3/2/2022	1	Mudflat survey	NA	NA	NA	MF05	1.40796013	103.978653	5	1415-1715	<i>Family Tellinidae</i>	1	Seen	Z70795	Targeted	
3/2/2022	1	Mudflat survey	NA	NA	NA	MF05	1.40796013	103.978653	5	1415-1715	<i>Donax sp.</i>	1	Seen	Z70796-0800	Targeted	Juvenile
3/2/2022	1	Mudflat survey	NA	NA	NA	MF05	1.40796013	103.978653	5	1415-1715	<i>Nassarius fluviens</i>	1	Seen	Z70802	Targeted	
3/2/2022	1	Mudflat survey	NA	NA	NA	MF05	1.40796013	103.978653	5	1415-1715	<i>Nassarius echinatus</i>	1	Seen	Z70803-0804	Targeted	
3/2/2022	1	Mudflat survey	NA	NA	NA	MF05	1.40796013	103.978653	5	1415-1715	<i>Family Corbiculidae</i>	1	Seen	DS000791_Family Corbiculidae	Targeted	
3/2/2022	1	Mudflat survey	NA	NA	NA	MF05	1.40796013	103.978653	5	1415-1715	<i>Bogomys squamosus</i>	1	Seen	DS000786_Bogomys squamosus	Targeted	
3/2/2022	1	Mudflat survey	NA	NA	NA	MF05	1.40796013	103.978653	5	1415-1715	<i>Corbulus sp.</i>	1	Seen	DS000796_Corbula sp.	Targeted	
3/11/2022	2	T1	SZ2708	1.40879497	103.979659	NA	NA	NA	NA	918	<i>Eumeces aff. parvulus</i>	1	Seen		Targeted	
3/11/2022	2	T1	SZ2709	1.40879498	103.979653	NA	NA	NA	NA	921	<i>Agia sp.</i>	1	Seen		Targeted	
3/11/2022	2	T1	SZ2709	1.40901804	103.976553	NA	NA	NA	NA	921	<i>Ignotia baldus newboldi</i>	1	Seen		Targeted	
3/11/2022	2	T1	SZ2710	1.40847476	103.977233	NA	NA	NA	NA	929	<i>Agia corana</i>	1	Seen		Targeted	
3/11/2022	2	T1	SZ2710	1.40847476	103.977233	NA	NA	NA	NA	929	<i>Agia corana</i>	1	Seen		Targeted	
3/11/2022	2	T1	SZ2710	1.40847476	103.977233	NA	NA	NA	NA	931	<i>Amathusia philippus philippus</i>	2	Seen		Targeted	
3/11/2022	2	T1	SZ2711	1.40799704	103.977749	NA	NA	NA	NA	935	<i>Strombosyllina purpurata</i>	1	Seen		Targeted	sp. 2
3/11/2022	2	T1	SZ2711	1.40784069	103.977548	NA	NA	NA	NA	940	<i>Stalga opus opus</i>	1	Seen		Targeted	
3/11/2022	2	T1	SZ2711	1.40784069	103.977548	NA	NA	NA	NA	940	<i>Agia affinis</i>	1	Seen		Targeted	
3/11/2022	2	T1	SZ2711	1.40784069	103.977548	NA	NA	NA	NA	940	<i>Pantopora paraka paraka</i>	1	Seen		Targeted	
3/11/2022	2	T1	SZ2711	1.40784069	103.977548	NA	NA	NA	NA	940	<i>Pantopora paraka paraka</i>	1	Seen		Targeted	
3/11/2022	2	T1	SZ2711	1.40784069	103.977548	NA	NA	NA	NA	940	<i>Mitostoma peroxide peroxide</i>	1	Seen		Targeted	
3/11/2022	2	T1	SZ2711	1.40784069	103.977548	NA	NA	NA	NA	940	<i>Amathusia philippus philippus</i>	1	Seen		Targeted	
3/11/2022	2	T1	SZ2712	1.40786780	103.977074	NA	NA	NA	NA	953	<i>Strombosyllina haemorrhoidale</i>	1	Seen		Targeted	
3/11/2022	2	T1	SZ2712	1.40786780	103.977074	NA	NA	NA	NA	953	<i>Xenochironomus</i>	1	Seen		Targeted	Not in database
3/11/2022	2	T1	SZ2711	1.40784069	103.977548	NA	NA	NA	NA	1000	<i>Polyura schreiber isanumus</i>	1	Seen		Targeted	
3/11/2022	2	T1	SZ2715	1.40815979	103.977488	NA	NA	NA	NA	1002	<i>Polyura mooni mooni</i>	1	Seen		Targeted	IMG_5193_Polyura mooni mooni
3/11/2022	2	T2	SZ2716	1.40922681	103.977674	NA	NA	NA	NA	1000	<i>Dialia hypermetrae medietate</i>	1	Seen		Targeted	
3/11/2022	2	T2	SZ2717	1.40979458	103.977991	NA	NA	NA	NA	1023	<i>Parichthogaster malayi</i>	1	Seen		Targeted	
3/11/2022	2	T2	SZ2718	1.41020924	103.978065	NA	NA	NA	NA	1027	<i>Parichthogaster malayi</i>	1	Seen		Targeted	
3/11/2022	2	T2	SZ2718	1.41020924	103.978065	NA	NA	NA	NA	1027	<i>Parichthogaster malayi</i>	1	Seen		Targeted	
3/11/2022	2	T2	SZ2719	1.411151988	103.977971	NA	NA	NA	NA	1037	<i>Eumeces hypermetrae agnia</i>	1	Seen		Targeted	
3/11/2022	2	T2	SZ2719	1.411151988	103.977971	NA	NA	NA	NA	1040	<i>Papilio polytes romulus</i>	1	Seen		Targeted	
3/11/2022	2	T2	SZ2720	1.411189036	103.978007	NA	NA	NA	NA	1042	<i>Eumeces hypermetrae agnia</i>	4	Seen		Targeted	
3/11/2022	2	T2	SZ2720	1.411189036	103.978007	NA	NA	NA	NA	1042	<i>Athyia netta subrata</i>	1	Seen		Targeted	
3/11/2022	2	T2	SZ2721	1.41084027	103.978442	NA	NA	NA	NA	1048	<i>Eumeces sp.</i>	1	Seen		Targeted	
3/11/2022	2	T2	SZ2722	1.41084027	103.978442	NA	NA	NA	NA	1048	<i>Eumeces sp.</i>	1	Seen		Targeted	
3/11/2022	2	T2	SZ2723	1.410474982	103.978765	NA	NA	NA	NA	1053	<i>Eumeces blanda sphenoti</i>	1	Seen		Targeted	three spots
3/11/2022	2	T2	SZ2723	1.410474982	103.978765	NA	NA	NA	NA	1053	<i>Papilio polytes romulus</i>	1	Seen		Targeted	
3/11/2022	2	T2	SZ2723	1.410474982	103.978765	NA	NA	NA	NA	1053	<i>Papilio polytes romulus</i>	1	Seen		Targeted	
3/11/2022	2	T2	SZ2723													

Date	Cycle	Route	Waypoint	Latitude	Longitude	Sampling point	Latitude	Longitude	Quadrat	Time (24h)	Scientific name	Quantity	Observation type (seen/heard/caught/other signs)	Photo no.	Survey method (targeted/incidental/point count/trapping)	Remarks
3/18/2022	2	T2	HB3073	1.41067	103.97841	NA	NA	NA	1004	1004	<i>Pantopsis paraka paraka</i>	1	Seen		Targeted	
3/18/2022	2	T2	HB3073	1.41067	103.97841	NA	NA	NA	1004	1004	<i>Papilio polytes romulus</i>	1	Seen		Targeted	
3/18/2022	2	T2	HB3073	1.41067	103.97841	NA	NA	NA	1004	1004	<i>Homobotys omis</i>	3	Seen	HW4270_48	Incidental	
3/18/2022	2	T2	HB3074	1.41166035	103.978154	NA	NA	NA	1014	1014	<i>Agrionoptera insigis</i>	1	Seen		Targeted	
3/18/2022	2	T2	HB3075	1.41101704	103.977951	NA	NA	NA	1016	1016	<i>Lebadea murtha malayana</i>	1	Seen		Targeted	
3/18/2022	2	T2	HB3075	1.41101704	103.977951	NA	NA	NA	1016	1016	<i>Unidentified hymenoptera</i>	1	Seen		Targeted	
3/18/2022	2	T2	HB3077	1.41031026	103.977976	NA	NA	NA	1021	1021	<i>Delias hypocrite metarata</i>	1	Seen		Targeted	Didn't stop. Either blue or dark glossy tiger
3/18/2022	2	T2	HB3077	1.41031026	103.977976	NA	NA	NA	1021	1021	<i>Eurymia sp.</i>	1	Seen		Targeted	
3/18/2022	2	T2	HB3078	1.40917103	103.977976	NA	NA	NA	1024	1024	<i>Cratichneumon</i>	1	Seen	HW4271_74	Targeted	
3/18/2022	2	T2	HB3079	1.40944959	103.977178	NA	NA	NA	1027	1027	<i>Lebadea murtha malayana</i>	1	Seen		Targeted	
3/18/2022	2	T2	HB3080	1.40910015	103.977284	NA	NA	NA	1029	1029	<i>Delias hypocrite metarata</i>	2	Seen		Targeted	
3/18/2022	2	T2	HB3080	1.40910015	103.977284	NA	NA	NA	1029	1029	<i>Climax trapezocera</i>	1	Heard		Incidental	
3/18/2022	2	T1	HB3081	1.40792001	103.975031	NA	NA	NA	1038	1038	<i>Polysia moori moori</i>	1	Seen	Can XX	Incidental	walking in
3/18/2022	2	T1	HB3082	1.40758909	103.973737	NA	NA	NA	1044	1044	<i>Polysia moori moori</i>	1	Seen	HW4278_Can XX	Incidental	walking in
3/18/2022	2	T1	HB3084	1.40750134	103.971462	NA	NA	NA	1047	1047	<i>Polysia moori moori</i>	1	Seen		Incidental	walking in
3/18/2022	2	T1	HB3084	1.40759959	103.978401	NA	NA	NA	1053	1053	<i>Trama transmiana</i>	1	Seen		Targeted	
3/18/2022	2	T1	HB3084	1.40759959	103.978401	NA	NA	NA	1053	1053	<i>Paraglyphalmus argentimaculatus</i>	1	Seen	SS	Incidental	
3/18/2022	2	T1	HB3084	1.40759959	103.978401	NA	NA	NA	1053	1053	<i>Monopota latio</i>	2	Seen		Incidental	
3/18/2022	2	T1	HB3084	1.40759959	103.978401	NA	NA	NA	1053	1053	<i>Cibanius longitarus</i>	1	Seen		Incidental	
3/18/2022	2	NA	HB3085	1.4078222	103.97987	NA	NA	NA	1059	1059	<i>cf. Cassida aurifrons</i>	1	Seen	SS	Incidental	part of Cassida aurifrons
3/18/2022	2	T1	HB3085	1.40789434	103.977784	NA	NA	NA	1103	1103	<i>Graphium dixon everardii</i>	1	Seen		Targeted	
3/18/2022	2	T1	HB3085	1.40789434	103.977784	NA	NA	NA	1103	1103	<i>Paraglyphalmus walabakae</i>	1	Seen	SS	Incidental	
3/18/2022	2	T1	HB3086	1.40762008	103.97767	NA	NA	NA	1103	1103	<i>Trama transmiana</i>	1	Seen		Targeted	
3/18/2022	2	T1	HB3086	1.40762008	103.97767	NA	NA	NA	1106	1106	<i>Carex sarax sumatrana</i>	1	Seen		Targeted	
3/18/2022	2	T1	HB3086	1.40762008	103.97767	NA	NA	NA	1106	1106	<i>Elfbria conica</i>	1	Seen		Incidental	
3/18/2022	2	T1	HB3087	1.40809977	103.97748	NA	NA	NA	1110	1110	<i>Trama transmiana</i>	1	Seen		Targeted	
3/18/2022	2	T1	HB3087	1.40809977	103.97748	NA	NA	NA	1113	1113	<i>Rhynchomys zhyzhy</i>	1	Seen		Targeted	
3/18/2022	2	T1	HB3088	1.40837692	103.977288	NA	NA	NA	1117	1117	<i>Eutopis muflicascata</i>	1	Seen		Incidental	
3/18/2022	2	T1	HB3089	1.40850493	103.977282	NA	NA	NA	1118	1118	<i>Idopos vulgaris malaya</i>	1	Seen		Targeted	
3/18/2022	2	T1	HB3089	1.40850493	103.977282	NA	NA	NA	1120	1120	<i>Lebadea murtha malayana</i>	1	Seen		Targeted	
3/18/2022	2	T1	HB3090	1.40909062	103.976795	NA	NA	NA	1124	1124	<i>Canachia gigantea</i>	4	Seen		Targeted	
3/18/2022	2	T1	HB3090	1.40909062	103.976795	NA	NA	NA	1124	1124	<i>Trama transmiana</i>	1	Seen		Targeted	
3/18/2022	2	T1	HB3090	1.40909062	103.976795	NA	NA	NA	1124	1124	<i>Delias hypocrite metarata</i>	1	Seen		Targeted	
3/18/2022	2	T1	HB3090	1.40909062	103.976795	NA	NA	NA	1124	1124	<i>Eymisla hypermetra agria</i>	1	Seen		Targeted	
3/18/2022	2	T1	HB3090	1.40909062	103.976795	NA	NA	NA	1124	1124	<i>Indrithia balda newboldi</i>	1	Seen		Targeted	
3/18/2022	2	T1	HB3090	1.40909062	103.976795	NA	NA	NA	1128	1128	<i>Agriopoptera insigis</i>	1	Seen		Targeted	
3/18/2022	2	T1	HB3090	1.40909062	103.976795	NA	NA	NA	1128	1128	<i>Lebadea murtha malayana</i>	1	Seen		Targeted	
3/18/2022	2	T1	HB3091	1.40889503	103.976618	NA	NA	NA	1130	1130	<i>Alphacodanus</i>	2	Seen		Targeted	
3/18/2022	2	T1	HB3091	1.40889503	103.976618	NA	NA	NA	1130	1130	<i>Pantopsis paraka paraka</i>	1	Seen		Targeted	
3/18/2022	2	T1	HB3091	1.40889503	103.976618	NA	NA	NA	1130	1130	<i>Unidentified</i>	1	Seen	Can XX	Incidental	Can to id
3/18/2022	2	T1	HB3092	1.40888568	103.976207	NA	NA	NA	1139	1139	<i>Mitopus sp.</i>	1	Seen	Can XX	Targeted	
3/18/2022	2	T1	HB3092	1.40888568	103.976207	NA	NA	NA	1139	1139	<i>Orthetrum chrys</i>	1	Seen		Targeted	
3/18/2022	2	T1	HB3093	1.40818008	103.975191	NA	NA	NA	1148	1148	<i>Cephus malindang</i>	1	Seen		Targeted	
3/18/2022	2	T1	HB3094	1.40816513	103.975645	NA	NA	NA	1151	1151	<i>Eymisla hypermetra agria</i>	2	Seen		Targeted	By fast, would not stop. No photo
3/18/2022	2	T1	HB3094	1.40816513	103.975645	NA	NA	NA	1209	1209	<i>Unidentified Skipper/Dart</i>	1	Seen	Can XX	Incidental	walking out. Can to id
3/18/2022	2	T1	HB3094	1.40816513	103.975645	NA	NA	NA	1209	1209	<i>Trama transmiana</i>	1	Seen		Incidental	walking out
3/18/2022	2	T1	HB3094	1.40816513	103.975645	NA	NA	NA	1209	1209	<i>Rhynchomys zhyzhy</i>	1	Seen		Incidental	walking out
3/18/2022	2	T1	HB3094	1.40816513	103.975645	NA	NA	NA	1209	1209	<i>Yarica dyasoma</i>	10	Seen		Incidental	spot at caudal fin. A school of them
3/18/2022	2	T1	HB3095	1.40820401	103.97579	NA	NA	NA	1151	1151	<i>Unidentified hymenoptera</i>	1	Seen		Incidental	blue or dark glossy. Didn't stop
3/18/2022	2	T1	HB3096	1.407834012	103.97819	NA	NA	NA	1155	1155	<i>Carex sarax sumatrana</i>	1	Seen		Incidental	
3/18/2022	2	T1	HB3096	1.407834012	103.97819	NA	NA	NA	1155	1155	<i>Troctes jaculatrix</i>	>1	Seen		Incidental	
3/18/2022	2	T1	HB3097	1.40778529	103.97887	NA	NA	NA	1159	1159	<i>Trama transmiana</i>	1	Seen		Targeted	
3/18/2022	2	T1	HB3097	1.40778529	103.97887	NA	NA	NA	1159	1159	<i>Stomoxys calcitrans</i>	1	Seen		Targeted	
3/18/2022	2	T1	HB3098	1.40766503	103.97809	NA	NA	NA	1203	1203	<i>Pantopsis paraka paraka</i>	2	Seen		Targeted	I oviposit on <i>Diabasys</i> sp. climber. Blue egg
3/18/2022	2	T1	SB771			NA	NA	NA	1220	1220	<i>Phaenocarpa phanocarpa</i>	1	Seen		Incidental	walking out
2/16/2022	1	Mudflat survey	S2362	1.40742202	103.976602	MF01	1.40736015	103.976599	7	1630-1800	Quadrat	NA	Seen	P216055_MF0307	Targeted	walking out
2/16/2022	1	Mudflat survey	S2362	1.40742202	103.976602	MF01	1.40736015	103.976599	7	1630-1800	Telescopium telescopium	NA	Seen		Targeted	
2/16/2022	1	Mudflat survey	S2362	1.40742202	103.976602	MF01	1.40736015	103.976599	7	1630-1800	Uva	NA	Seen		Targeted	
2/16/2022	1	Mudflat survey	S2362	1.40742202	103.976602	MF01	1.40736015	103.976599	7	1630-1800	<i>Anomalobius squamosus</i>	NA	Seen		Targeted	
2/16/2022	1	Mudflat survey	S2362	1.40742202	103.976602	MF01	1.40736015	103.976599	7	1630-1800	<i>Ophiostoma berkeleyi</i>	NA	Seen		Targeted	
2/16/2022	1	Mudflat survey	S2362	1.40742202	103.976602	MF01	1.40736015	103.976599	7	1630-1800	<i>Acrostichum</i>	NA	Seen		Targeted	
2/16/2022	1	Mudflat survey	S2362	1.40742202	103.976602	MF01	1.40736015	103.976599	7	1630-1800	<i>Stilbium zonaria</i>	NA	Seen		Targeted	
2/16/2022	1	Mudflat survey	S2362	1.40742202	103.976602	MF01	1.40736015	103.976599	7	1630-1800	<i>Diglosses sp.</i>	1	Seen		Targeted	
2/16/2022	1	Mudflat survey	S2362	1.40742202	103.976602	MF01	1.40736015	103.976599	7	1630-1800	<i>Pireneis cingulata</i>	NA	Seen		Targeted	
2/16/2022	1	Mudflat survey	S2362	1.40742202	103.976602	MF01	1.40736015	103.976599	7	1630-1800	<i>Cerithium corallium</i>	NA	Seen		Targeted	P216098_Cerithium corallium
2/16/2022	1	Mudflat survey	S2362	1.40742202	103.976602	MF01	1.40736015	103.976599	5	1630-1800	Quadrat	NA	Seen		Targeted	P216059_MF0305
2/16/2022	1	Mudflat survey	S2362	1.40742202	103.976602	MF01	1.40736015	103.976599	5	1630-1800	<i>Ophiostoma berkeleyi</i>	NA	Seen		Targeted	
2/16/2022	1	Mudflat survey	S2362	1.40742202	103.976602	MF01	1.40736015	103.976599	5	1630-1800	<i>Glycyca urticomis</i>	NA	Seen		Targeted	P216060_Glycyca urticomis
2/16/2022	1	Mudflat survey	S2362	1.40742202	103.976602	MF01	1.40736015	103.976599	5	1630-1800	<i>Anomalobius squamosus</i>	NA	Seen		Targeted	
2/16/2022	1	Mudflat survey	S2362	1.40742202	1											

Date	Cycle	Route	Waypoint	Latitude	Longitude	Sampling point	Latitude	Longitude	Quadrat	Time (24h)	Scientific name	Quantity	Observation type (seen/heard/caught/scat/other signs)	Photo no.	Survey method (targeted/incidental/point count/trapping)	Remarks
2/16/2022	1	Mudflat survey	S2363	1.40820495	103.976679	MFO3	1.40820495	103.976679	6	1630-1800	<i>Indohyas gradata</i>	1	Seen		Targeted	
2/16/2022	1	Mudflat survey	S2363	1.40820495	103.976679	MFO3	1.40820495	103.976679	6	1630-1800	<i>Digenea</i> sp.	1	Seen		Targeted	
2/16/2022	1	Mudflat survey	S2363	1.40820495	103.976679	MFO3	1.40820495	103.976679	6	1630-1800	<i>Cithon oxaltesense</i>	1	Seen		Targeted	
2/16/2022	1	Mudflat survey	S2363	1.40820495	103.976679	MFO3	1.40820495	103.976679	4	1630-1800	Quadrat	NA	Seen		Targeted	
2/16/2022	1	Mudflat survey	S2363	1.40820495	103.976679	MFO3	1.40820495	103.976679	4	1630-1800	<i>Anolisia orientalis</i>	1	Seen		Targeted	
2/16/2022	1	Mudflat survey	S2363	1.40820495	103.976679	MFO3	1.40820495	103.976679	4	1630-1800	<i>Battalia</i>	1	Seen		Targeted	
2/16/2022	1	Mudflat survey	S2363	1.40820495	103.976679	MFO3	1.40820495	103.976679	4	1630-1800	<i>Angitia gracilis</i>	1	Seen		Targeted	P216044_Ampia gracilis
2/16/2022	1	Mudflat survey	S2363	1.40820495	103.976679	MFO3	1.40820495	103.976679	4	1630-1800	<i>Nassarius jacksonius</i>	1	Seen		Targeted	
2/16/2022	1	Mudflat survey	S2363	1.40820495	103.976679	MFO3	1.40820495	103.976679	4	1630-1800	<i>Cithon oxaltesense</i>	1	Seen		Targeted	
2/16/2022	1	Mudflat survey	S2363	1.40820495	103.976679	MFO3	1.40820495	103.976679	4	1630-1800	<i>Anomalidicus squamosus</i>	1	Seen		Targeted	
2/16/2022	1	Mudflat survey	S2363	1.40820495	103.976679	MFO3	1.40820495	103.976679	4	1630-1800	<i>Plicamen chironotum</i>	1	Seen		Targeted	
2/16/2022	1	Mudflat survey	S2363	1.40820495	103.976679	MFO3	1.40820495	103.976679	4	1630-1800	<i>Mitrella brookeri</i>	1	Seen		Targeted	
2/16/2022	1	Mudflat survey	S2363	1.40820495	103.976679	MFO3	1.40820495	103.976679	4	1630-1800	<i>Nassarius olivaceus</i>	1	Seen		Targeted	P216063_Nassarius olivaceus
2/16/2022	1	Mudflat survey	S2363	1.40820495	103.976679	MFO3	1.40820495	103.976679	4	1630-1800	<i>Family Filicidae</i>	1	Seen		Targeted	P216044_Leptoides sp.
2/16/2022	1	Mudflat survey	S2363	1.40820495	103.976679	MFO3	1.40820495	103.976679	4	1630-1800	<i>Mercia japonica</i>	1	Seen		Targeted	P2160621_Mercia japonica
2/16/2022	1	Mudflat survey	S2363	1.40820495	103.976679	MFO3	1.40820495	103.976679	4	1630-1800	<i>Cerithium corallum</i>	1	Seen		Targeted	
2/16/2022	1	Mudflat survey	S2363	1.40820495	103.976679	MFO3	1.40820495	103.976679	4	1630-1800	<i>Battalia zonalis</i> and <i>Battalia zonalis</i> and <i>Pireneia conglata</i>	1	Seen		Targeted	P2160615_Cerithium corallum and Battalia zonalis and Pireneia conglata
2/16/2022	1	Mudflat survey	S2363	1.40820495	103.976679	MFO3	1.40820495	103.976679	NA	1630-1800	<i>Portunus pelagicus</i>	1	Seen		Targeted	P215619_Portunus pelagicus
2/16/2022	1	Mudflat survey	S2362	1.40742202	103.976602	MFO1	1.40736015	103.976599	1	1630-1800	<i>Family Calceommatidae</i>	1	Seen		Targeted	P216065_Family Calceommatidae Scintilla clam
2/16/2022	2	Mudflat survey	NA	NA	NA	MFO9	1.40997607	103.978336	11	0800-1200	<i>Peripatulus argentinellus</i>	1	Seen		Targeted	P216058_Peripatulus argentinellus
2/16/2022	2	Mudflat survey	NA	NA	NA	MFO9	1.40997607	103.978336	11	0800-1200	Quadrat	NA	Seen		Targeted	SS762
2/25/2022	2	Mudflat survey	NA	NA	NA	MFO9	1.40997607	103.978336	11	0800-1200	<i>Ophidrosus brevisulcum</i>	51	Seen		Targeted	
2/25/2022	2	Mudflat survey	NA	NA	NA	MFO9	1.40997607	103.978336	11	0800-1200	<i>Alagea gracilis</i>	3	Seen		Targeted	
2/25/2022	2	Mudflat survey	NA	NA	NA	MFO9	1.40997607	103.978336	11	0800-1200	<i>Doris</i> sp.	1	Seen		Targeted	
2/25/2022	2	Mudflat survey	NA	NA	NA	MFO9	1.40997607	103.978336	11	0800-1200	<i>Cerithium corallum</i>	1	Seen		Targeted	SS767
2/25/2022	2	Mudflat survey	NA	NA	NA	MFO9	1.40997607	103.978336	8	0800-1200	Quadrat	NA	Seen		Targeted	SS762
2/25/2022	2	Mudflat survey	NA	NA	NA	MFO9	1.40997607	103.978336	8	0800-1200	<i>Doris</i> sp.	2	Seen		Targeted	
2/25/2022	2	Mudflat survey	NA	NA	NA	MFO9	1.40997607	103.978336	8	0800-1200	<i>Cerithium corallum</i>	2	Seen		Targeted	
2/25/2022	2	Mudflat survey	NA	NA	NA	MFO9	1.40997607	103.978336	8	0800-1200	<i>Doris</i> sp.	2	Seen		Targeted	
2/25/2022	2	Mudflat survey	NA	NA	NA	MFO9	1.40997607	103.978336	8	0800-1200	<i>Mercia japonica</i>	8	Seen		Targeted	Specimen
2/25/2022	2	Mudflat survey	NA	NA	NA	MFO9	1.40997607	103.978336	2	0800-1200	Quadrat	NA	Seen		Targeted	SS784
2/25/2022	2	Mudflat survey	NA	NA	NA	MFO9	1.40997607	103.978336	2	0800-1200	<i>Ophidrosus brevisulcum</i>	51	Seen		Targeted	SS815 specimen
2/25/2022	2	Mudflat survey	NA	NA	NA	MFO9	1.40997607	103.978336	2	0800-1200	<i>Chironotus</i> sp.	2	Seen		Targeted	SS783
2/25/2022	2	Mudflat survey	NA	NA	NA	MFO9	1.40997607	103.978336	2	0800-1200	<i>Dipodomys bifasciata</i>	2	Seen		Targeted	SS818
2/25/2022	2	Mudflat survey	NA	NA	NA	MFO9	1.40997607	103.978336	2	0800-1200	<i>Family Ostreidae</i>	1	Seen		Targeted	SS810
2/25/2022	2	Mudflat survey	NA	NA	NA	MFO9	1.40997607	103.978336	2	0800-1200	<i>Pisna</i> sp.	2	Seen		Targeted	SS807
2/25/2022	2	Mudflat survey	NA	NA	NA	MFO9	1.40997607	103.978336	NA	0800-1200	<i>Trochospira telescopium</i>	1	Seen		Targeted	Incidental
2/25/2022	2	Mudflat survey	NA	NA	NA	MFO9	1.40997607	103.978336	NA	0800-1200	<i>Tenebralis sulcata</i>	1	Seen		Targeted	Incidental
2/25/2022	2	Mudflat survey	NA	NA	NA	MFO9	1.40997607	103.978336	15	0800-1200	Quadrat	NA	Seen		Targeted	
2/25/2022	2	Mudflat survey	NA	NA	NA	MFO9	1.40997607	103.978336	15	0800-1200	<i>Uva</i> sp.	NA	Seen		Targeted	
2/25/2022	2	Mudflat survey	NA	NA	NA	MFO9	1.40997607	103.978336	15	0800-1200	<i>Chalcidomorpha gracilis</i>	NA	Seen		Targeted	
2/25/2022	2	Mudflat survey	NA	NA	NA	MFO9	1.40997607	103.978336	15	0800-1200	<i>Hyacin</i> sp.	NA	Seen		Targeted	
2/25/2022	2	Mudflat survey	NA	NA	NA	MFO9	1.40997607	103.978336	15	0800-1200	<i>Anomalidicus squamosus</i>	10	Seen		Targeted	Specimen
2/25/2022	2	Mudflat survey	NA	NA	NA	MFO9	1.40997607	103.978336	15	0800-1200	<i>Pireneia cingulata</i>	3	Seen		Targeted	
2/25/2022	2	Mudflat survey	NA	NA	NA	MFO9	1.40997607	103.978336	15	0800-1200	<i>Cerithium corallum</i>	19	Seen		Targeted	
2/25/2022	2	Mudflat survey	NA	NA	NA	MFO9	1.40997607	103.978336	15	0800-1200	<i>Dipodomys bifasciata</i>	19	Seen		Targeted	SS856 specimen
2/25/2022	2	Mudflat survey	NA	NA	NA	MFO9	1.40997607	103.978336	15	0800-1200	<i>Plicamen chironotum</i>	2	Seen		Targeted	SS850
2/25/2022	2	Mudflat survey	NA	NA	NA	MFO9	1.40997607	103.978336	15	0800-1200	<i>Mitrella brookeri</i>	2	Seen		Targeted	SS868
2/25/2022	2	Mudflat survey	NA	NA	NA	MFO9	1.40997607	103.978336	15	0800-1200	<i>Nassarius jacksonius</i>	4	Seen		Targeted	SS852
2/25/2022	2	Mudflat survey	NA	NA	NA	MFO9	1.40997607	103.978336	15	0800-1200	<i>Digenea</i> sp.	17	Seen		Targeted	
2/25/2022	2	Mudflat survey	NA	NA	NA	MFO9	1.40997607	103.978336	15	0800-1200	<i>Phium nemorosum</i>	2	Seen		Targeted	SS869
2/25/2022	2	Mudflat survey	NA	NA	NA	MFO9	1.40997607	103.978336	15	0800-1200	<i>Gynerium nodosum</i>	4	Seen		Targeted	SS848 specimen
2/25/2022	2	Mudflat survey	NA	NA	NA	MFO9	1.40997607	103.978336	15	0800-1200	<i>Doris</i> sp.	4	Seen		Targeted	
2/25/2022	2	Mudflat survey	NA	NA	NA	MFO9	1.40997607	103.978336	15	0800-1200	<i>Doris</i> sp.	2	Seen		Targeted	
2/25/2022	2	Mudflat survey	NA	NA	NA	MFO9	1.40997607	103.978336	13	0800-1200	Quadrat	NA	Seen		Targeted	SS846
2/25/2022	2	Mudflat survey	NA	NA	NA	MFO9	1.40997607	103.978336	13	0800-1200	<i>Anomalidicus squamosus</i>	3	Seen		Targeted	
2/25/2022	2	Mudflat survey	NA	NA	NA	MFO9	1.40997607	103.978336	13	0800-1200	<i>Cerithium corallum</i>	12	Seen		Targeted	
2/25/2022	2	Mudflat survey	NA	NA	NA	MFO9	1.40997607	103.978336	13	0800-1200	<i>Cerithium corallum</i>	13	Seen		Targeted	
2/25/2022	2	Mudflat survey	NA	NA	NA	MFO9	1.40997607	103.978336	13	0800-1200	<i>Chalcidomorpha gracilis</i>	NA	Seen		Targeted	
2/25/2022	2	Mudflat survey	NA	NA	NA	MFO9	1.40997607	103.978336	13	0800-1200	<i>Digenea</i> sp.	5	Seen		Targeted	
2/25/2022	2	Mudflat survey	NA	NA	NA	MFO9	1.40997607	103.978336	13	0800-1200	<i>Nassarius jacksonius</i>	1	Seen		Targeted	Specimen
2/25/2022	2	Mudflat survey	NA	NA	NA	MFO9	1.40997607	103.978336	13	0800-1200	<i>Family Ostreidae</i>	1	Seen		Targeted	
2/25/2022	2	Mudflat survey	NA	NA	NA	MFO9	1.40997607	103.978336	13	0800-1200	<i>Family Ostreidae</i>	1	Seen		Targeted	SS924
2/25/2022	2	Mudflat survey	NA	NA	NA	MFO9	1.40997607	103.978336	4	0800-1200	<i>Arctostem</i> sp.	NA	Seen		Targeted	
2/25/2022	2	Mudflat survey	NA	NA	NA	MFO9	1.40997607	103.978336	4	0800-1200	<i>Fragaria nardifolia</i>	1	Seen		Targeted	
2/25/2022	2	Mudflat survey	NA	NA	NA	MFO9	1.40997607	103.978336	4	0800-1200	<i>Pisna</i> sp.	4	Seen		Targeted	SS918
2/25/2022	2	Mudflat survey	NA	NA	NA	MFO9	1.40997607	103.978336	4	0800-1200	<i>Pireneia cingulata</i>	7	Seen		Targeted	SS922
2/25/2022	2	Mudflat survey	NA	NA	NA	MFO9	1.40997607	103.978336	4	0800-1200	<i>Cerithium corallum</i>	42	Seen		Targeted	
2/25/2022	2	Mudflat survey														

Date	Cycle	Route	Waypoint	Latitude	Longitude	Sampling point	Latitude	Longitude	Quadrat	Time (24h)	Scientific name	Quantity	Observation type (seen/heard/caught/sat/other signs)	Photo no.	Survey method (targeted/incidental/point count/trapping)	Remarks
3/2/2022	1	Mufflat survey	NA	NA	NA	MFB	1.40749997	103.977995	0	1415 1715	<i>Nerita helvis</i>	2	Seen	Z1084.0845	Targeted	
3/2/2022	1	Mufflat survey	NA	NA	NA	MFB	1.40749997	103.977995	0	1415 1715	<i>Parasitiscus gairdneri</i>	1	Seen	Z1084.0845	Targeted	
3/2/2022	1	Mufflat survey	NA	NA	NA	MFB	1.40749997	103.977995	0	1415 1715	<i>Mitrella brookeri</i>	49	Seen	Z1084.0849	Targeted	
3/2/2022	1	Mufflat survey	NA	NA	NA	MFB	1.40749997	103.977995	0	1415 1715	<i>Mitrella gunneri</i>	8	Seen	Z10872.0874	Targeted	
3/2/2022	1	Mufflat survey	NA	NA	NA	MFB	1.40749997	103.977995	0	1415 1715	<i>Luchelia</i> sp.	26	Seen	Z10862.0866	Targeted	
3/2/2022	1	Mufflat survey	NA	NA	NA	MFB	1.40749997	103.977995	0	1415 1715	<i>Anadara inaequalivalis</i>	1	Seen	DISC00842, Anadara inaequalivalis	Targeted	
3/2/2022	1	Mufflat survey	NA	NA	NA	MFB	1.40749997	103.977995	0	1415 1715	<i>Nerita balliana</i>	2	Seen	Z10843	Targeted	
3/2/2022	1	Mufflat survey	NA	NA	NA	MFB	1.40749997	103.977995	0	1415 1715	<i>Family Didymidae</i>	1	Seen	Z10846-0847	Targeted	
3/2/2022	1	Mufflat survey	NA	NA	NA	MFB	1.40749997	103.977995	0	1415 1715	<i>Pireneia cingulata</i>	3	Seen	Z107852	Targeted	
3/2/2022	1	Mufflat survey	NA	NA	NA	MFB	1.40749997	103.977995	0	1415 1715	<i>Pireneia microptera</i>	1	Seen	DISC00882, Pireneia microptera Pireneia cingulata	Targeted	
3/2/2022	1	Mufflat survey	NA	NA	NA	MFB	1.40749997	103.977995	0	1415 1715	<i>Trochilium nodifera</i>	30	Seen	Z10842	Targeted	
3/2/2022	1	Mufflat survey	NA	NA	NA	MFB	1.40749997	103.977995	0	1415 1715	<i>Ulva</i> sp.	1	Seen	Z10841	Targeted	
3/2/2022	1	Mufflat survey	NA	NA	NA	MFB	1.40749997	103.977995	0	1415 1715	<i>Nassarius brevicornis</i>	4	Seen	Z10879-0882	Targeted	
3/2/2022	1	Mufflat survey	NA	NA	NA	MFB	1.40749997	103.977995	0	1415 1715	<i>Family Muricidae</i>	1	Seen	Z10881-0884	Targeted	
3/2/2022	1	Mufflat survey	NA	NA	NA	MFB	1.40749997	103.977995	0	1415 1715	<i>Family Veneridae 1</i>	1	Seen	Z10884-0889	Targeted	
3/2/2022	1	Mufflat survey	NA	NA	NA	MFB	1.40749997	103.977995	0	1415 1715	<i>Family Veneridae 2</i>	2	Seen	Z10884-0887	Targeted	
3/2/2022	1	Mufflat survey	NA	NA	NA	MFB	1.40749997	103.977995	0	1415 1715	<i>Family Veneridae 3</i>	1	Seen	Z10860-0861	Targeted	
3/2/2022	1	Mufflat survey	NA	NA	NA	MFB	1.40749997	103.977995	0	1415 1715	<i>Coccolithus horridulus</i>	1	Seen	Z10884-0885	Targeted	
3/2/2022	1	Mufflat survey	NA	NA	NA	MFB	1.40749997	103.977995	0	1415 1715	<i>Tellina</i> sp.	2	Seen	Z10870-0871	Targeted	
3/2/2022	1	Mufflat survey	NA	NA	NA	MFB	1.40749997	103.977995	0	1415 1715	<i>Mitrella brookeri</i>	1	Seen	Z10870-0871	Targeted	
3/2/2022	1	Mufflat survey	NA	NA	NA	MFB	1.40749997	103.977995	0	1415 1715	<i>Anomaloidiscus squamosus</i>	19	Seen	Z10930-0931	Targeted	
3/2/2022	1	Mufflat survey	NA	NA	NA	MFB	1.40749997	103.977995	0	1415 1715	<i>Bullaria zonalis</i>	8	Seen	Z10930-0931	Targeted	
3/2/2022	1	Mufflat survey	NA	NA	NA	MFB	1.40749997	103.977995	10	1415 1715	<i>Pireneia microptera</i>	1	Seen	DISC00930, Pireneia microptera Cerithium coralium	Targeted	
3/2/2022	1	Mufflat survey	NA	NA	NA	MFB	1.40749997	103.977995	10	1415 1715	<i>Cerithium coralium</i>	1	Seen	DISC00930, Pireneia microptera Cerithium coralium	Targeted	
3/2/2022	1	Mufflat survey	NA	NA	NA	MFB	1.40749997	103.977995	10	1415 1715	<i>Crucella salicornea</i>	1	Seen	DISC00942, Crucella salicornea	Targeted	
3/2/2022	1	Mufflat survey	NA	NA	NA	MFB	1.40749997	103.977995	10	1415 1715	<i>Bygones</i> sp.	1%	Seen	Z10922	Targeted	
3/2/2022	1	Mufflat survey	NA	NA	NA	MFB	1.40749997	103.977995	10	1415 1715	<i>Austroliella corrugata</i>	1	Seen	DISC00923, Pacamen chondrius Austroliella corrugata	Targeted	
3/2/2022	1	Mufflat survey	NA	NA	NA	MFB	1.40749997	103.977995	10	1415 1715	<i>Corbula</i> sp.	2	Seen	Z10940	Targeted	
3/2/2022	1	Mufflat survey	NA	NA	NA	MFB	1.40749997	103.977995	10	1415 1715	<i>Family Galatomeiidae</i>	2	Seen	Z10928	Targeted	
3/2/2022	1	Mufflat survey	NA	NA	NA	MFB	1.40749997	103.977995	10	1415 1715	<i>Luchelia</i> sp.	11	Seen	Z10928	Targeted	
3/2/2022	1	Mufflat survey	NA	NA	NA	MFB	1.40749997	103.977995	10	1415 1715	<i>Serritina fusca</i>	10	Seen	Z10935-0936	Targeted	
3/2/2022	1	Mufflat survey	NA	NA	NA	MFB	1.40749997	103.977995	10	1415 1715	<i>Family Muricidae</i>	1	Seen	DISC00935, Family Muricidae Serritina fusca	Targeted	
3/2/2022	1	Mufflat survey	NA	NA	NA	MFB	1.40749997	103.977995	10	1415 1715	<i>Epilium</i> sp.	1	Seen	Z10932-0933	Targeted	
3/2/2022	1	Mufflat survey	NA	NA	NA	MFB	1.40749997	103.977995	10	1415 1715	<i>Pisacorn chondriolum</i>	2	Seen	Z10932-0933	Targeted	
3/2/2022	1	Mufflat survey	NA	NA	NA	MFB	1.40749997	103.977995	10	1415 1715	<i>Laemodonta</i> sp.	1	Seen	Z10939	Targeted	
3/2/2022	1	Mufflat survey	NA	NA	NA	MFB	1.40749997	103.977995	10	1415 1715	<i>Epilium scripta</i>	1	Seen	Z10941-0943	Targeted	
3/2/2022	1	Mufflat survey	NA	NA	NA	MFB	1.40749997	103.977995	10	1415 1715	<i>Bullaria</i> sp.	1	Seen	Z10925	Targeted	
3/2/2022	1	Mufflat survey	NA	NA	NA	MFB	1.40749997	103.977995	10	1415 1715	<i>Trochilium nodifera</i>	16	Seen	Z10922	Targeted	
3/2/2022	1	Mufflat survey	NA	NA	NA	MFB	1.40749997	103.977995	10	1415 1715	<i>Ulva</i> sp.	1%	Seen	Z10922	Targeted	
3/2/2022	1	Mufflat survey	NA	NA	NA	MFB	1.40749997	103.977995	10	1415 1715	<i>Nassarius brevicornis</i>	10	Seen	Z10929	Targeted	
3/2/2022	1	Mufflat survey	NA	NA	NA	MFB	1.40749997	103.977995	10	1415 1715	<i>Coccolithus horridulus</i>	3	Seen	Z10924-0927	Targeted	
3/2/2022	1	Mufflat survey	NA	NA	NA	MFB	1.40749997	103.977995	10	1415 1715	<i>Coccolithus horridulus</i>	10	Seen	Z10924	Targeted	
3/2/2022	1	Mufflat survey	NA	NA	NA	MFB	1.40749997	103.977995	5	1415 1715	<i>Anomaloidiscus squamosus</i>	5	Seen	Z10988	Targeted	
3/2/2022	1	Mufflat survey	NA	NA	NA	MFB	1.40749997	103.977995	5	1415 1715	<i>Bullaria zonalis</i>	12	Seen	Z10988	Targeted	
3/2/2022	1	Mufflat survey	NA	NA	NA	MFB	1.40749997	103.977995	5	1415 1715	<i>Bygones</i> sp.	1%	Seen	Z10889	Targeted	
3/2/2022	1	Mufflat survey	NA	NA	NA	MFB	1.40749997	103.977995	5	1415 1715	<i>Cerithium coralium</i>	5	Seen	Z10897	Targeted	
3/2/2022	1	Mufflat survey	NA	NA	NA	MFB	1.40749997	103.977995	5	1415 1715	<i>Pireneia cingulata</i>	4	Seen	DISC00988, Pireneia cingulata	Targeted	
3/2/2022	1	Mufflat survey	NA	NA	NA	MFB	1.40749997	103.977995	5	1415 1715	<i>Vitulum gunneri</i>	3	Seen	Z10904-0905	Targeted	
3/2/2022	1	Mufflat survey	NA	NA	NA	MFB	1.40749997	103.977995	5	1415 1715	<i>Mitrella brookeri</i>	36	Seen	Z10903	Targeted	
3/2/2022	1	Mufflat survey	NA	NA	NA	MFB	1.40749997	103.977995	5	1415 1715	<i>Luchelia</i> sp.	1	Seen	Z10903	Targeted	
3/2/2022	1	Mufflat survey	NA	NA	NA	MFB	1.40749997	103.977995	5	1415 1715	<i>Charatomorpha gracilis</i>	1%	Seen	Z10889	Targeted	
3/2/2022	1	Mufflat survey	NA	NA	NA	MFB	1.40749997	103.977995	5	1415 1715	<i>Bullaria</i> sp.	8	Seen	Z10904-0895	Targeted	
3/2/2022	1	Mufflat survey	NA	NA	NA	MFB	1.40749997	103.977995	5	1415 1715	<i>Nassarius brevicornis</i>	1	Seen	Z10911-0919	Targeted	
3/2/2022	1	Mufflat survey	NA	NA	NA	MFB	1.40749997	103.977995	5	1415 1715	<i>Nassarius pulfus</i>	3	Seen	Z10906-0907	Targeted	
3/2/2022	1	Mufflat survey	NA	NA	NA	MFB	1.40749997	103.977995	5	1415 1715	<i>Anadara inaequalivalis</i>	1	Seen	DISC00888, Anadara inaequalivalis Anomaloidiscus squamosus Trochilium sp	Targeted	
3/2/2022	1	Mufflat survey	NA	NA	NA	MFB	1.40749997	103.977995	5	1415 1715	<i>Epilium</i> sp.	15	Seen	Z10888	Targeted	
3/2/2022	1	Mufflat survey	NA	NA	NA	MFB	1.40749997	103.977995	5	1415 1715	<i>Ulva</i> sp.	93%	Seen	Z10889	Targeted	
3/2/2022	1	Mufflat survey	NA	NA	NA	MFB	1.40749997	103.977995	5	1415 1715	<i>Abropogon holobius</i>	1	Seen	VP1524	Incidental	
3/2/2022	1	Mufflat survey	NA	NA	NA	MFB	1.40749997	103.977995	5	1415 1715	<i>Cibicides (Puzosia) sp.</i>	1	Seen	VP1521-1521	Incidental	
3/2/2022	1	Mufflat survey	NA	NA	NA	MFB	1.40749997	103.977995	5	1415 1715	<i>Indohas gaudata</i>	1	Seen	VP1498-1502	Incidental	
3/2/2022	1	Mufflat survey	NA	NA	NA	MFB	1.40749997	103.977995	5	1415 1715	<i>Mitrella alba</i>	1	Seen	VP1503-1505	Incidental	
3/2/2022	1	Mufflat survey	NA	NA	NA	MFB	1.40749997	103.977995	5	1415 1715	<i>Nerita kanihatae</i>	1	Seen	VP1507-1508	Incidental	
3/2/2022	1	Mufflat survey	NA	NA	NA	MFB	1.40749997	103.977995	5	1415 1715	<i>Tellina</i> sp.	1	Seen	VP1517-1523	Incidental	
3/2/2022	2	Mufflat survey	NA	NA	NA	MFB	1.408027669	103.977202	10	0800 1200	<i>Indohas gaudata</i>	1	Seen	VP1506-1511	Incidental	
3/2/2022	2	Mufflat survey	NA	NA	NA	MFB	1.408027669	103.977202	10	0800 1200	<i>Anomaloidiscus squamosus</i>	4	Seen	MF04_10m_Z10031-33	Targeted	
3/2/2022	2	Mufflat survey	NA	NA	NA	MFB	1.408027669	103.977202	10	0800 1200	<i>Dicelidoros brevicornis</i>	6	Seen	MF04_10m_Z10034-38	Targeted	
3/2/2022	2	Mufflat survey	NA	NA	NA	MFB	1.408027669	103.977202	10	0800 1200	<i>Bullaria zonalis</i>	4	Seen	MF04_10m_Z10012-113	Targeted	
3/2/2022	2	Mufflat survey	NA	NA	NA	MFB	1.408027669	103.977202	10	0800 1200	<i>cf. Truncatella gunneri</i>	1	Seen	MF04_10m_Z10077-109	Targeted	
3/2/2022	2															

Date	Cycle	Route	Waypoint	Latitude	Longitude	Sampling point	Latitude	Longitude	Quadrat	Time (24h)	Scientific name	Quantity	Observation type (seen/heard/caught/scat/other signs)	Photo no.	Survey method (targeted/incidental/point count/trapping)	Remarks
3/24/2022	2	Mudflat survey	NA	NA	NA	MF04	1.408627969	103.977202	NA	0800-1200	<i>Cerithium corallium</i>	1	Seen	Z1059.1060	Incidental	
3/24/2022	2	Mudflat survey	NA	NA	NA	MF04	1.408627969	103.977202	NA	0800-1200	Family Limulidae	1	Seen	Z1071.4.1074	Incidental	
3/24/2022	2	Mudflat survey	NA	NA	NA	MF04	1.408627969	103.977202	NA	0800-1200	<i>Chrysis brevicornis</i>	1	Seen	Z1075.1076	Incidental	
3/24/2022	2	Mudflat survey	NA	NA	NA	MF04	1.408627969	103.977202	NA	0800-1200	<i>Paralichthys depressus</i>	1	Seen	Z1056.1058	Incidental	
3/24/2022	2	Mudflat survey	NA	NA	NA	MF04	1.408627969	103.977202	NA	0800-1200	<i>Pollanus pelagicus</i>	1	Seen	Z1039.1050	Incidental	Juvenile
3/24/2022	2	Mudflat survey	NA	NA	NA	MF04	1.408627969	103.977202	NA	0800-1200	<i>Pseudogobius aeneus</i>	1	Seen	Z1054.1054	Incidental	
3/24/2022	2	Mudflat survey	NA	NA	NA	MF04	1.408627969	103.977202	NA	0800-1200	<i>Tegulicera glauca</i>	1	Seen	Z1042.1043	Incidental	
3/24/2022	2	Mudflat survey	NA	NA	NA	MF10	1.40730008	103.977543	15	0800-1200	<i>Anomalidolcus squamatus</i>	51	Seen	MF10_15m_270034	Targeted	
3/24/2022	2	Mudflat survey	NA	NA	NA	MF10	1.40730008	103.977543	15	0800-1200	<i>Chaetomorpha</i> sp.	19	Seen	MF10_15m_270045	Targeted	
3/24/2022	2	Mudflat survey	NA	NA	NA	MF10	1.40730008	103.977543	15	0800-1200	<i>Cerithium corallium</i>	1	Seen	MF10_15m_270072.74	Targeted	
3/24/2022	2	Mudflat survey	NA	NA	NA	MF10	1.40730008	103.977543	15	0800-1200	<i>Mitrella brookeri</i>	2	Seen	MF10_15m_270066-67	Targeted	
3/24/2022	2	Mudflat survey	NA	NA	NA	MF10	1.40730008	103.977543	15	0800-1200	<i>Verrillium granulosum</i>	2	Seen	MF10_15m_27004.45	Targeted	
3/24/2022	2	Mudflat survey	NA	NA	NA	MF10	1.40730008	103.977543	15	0800-1200	<i>Corbula</i> sp.	4	Seen	MF10_15m_270046	Targeted	
3/24/2022	2	Mudflat survey	NA	NA	NA	MF10	1.40730008	103.977543	15	0800-1200	<i>Placamen chirovotum</i>	2	Seen	MF10_15m_270041.42	Targeted	
3/24/2022	2	Mudflat survey	NA	NA	NA	MF10	1.40730008	103.977543	15	0800-1200	<i>cf. Heterocidaris albostriata</i>	1	Seen		Targeted	
3/24/2022	2	Mudflat survey	NA	NA	NA	MF10	1.40730008	103.977543	15	0800-1200	<i>cf. Muretopoda pelliculata</i>	1	Seen		Targeted	
3/24/2022	2	Mudflat survey	NA	NA	NA	MF10	1.40730008	103.977543	15	0800-1200	<i>cf. Micromastax angulifera</i>	1	Seen		Targeted	
3/24/2022	2	Mudflat survey	NA	NA	NA	MF10	1.40730008	103.977543	15	0800-1200	<i>cf. Balanus pelliculata</i>	1	Seen		Targeted	
3/24/2022	2	Mudflat survey	NA	NA	NA	MF10	1.40730008	103.977543	15	0800-1200	<i>Family Phoridae</i>	1	Seen	MF10_15m_270062.64	Targeted	
3/24/2022	2	Mudflat survey	NA	NA	NA	MF10	1.40730008	103.977543	15	0800-1200	<i>Family Phoridae</i>	1	Seen	MF10_15m_270047.48	Targeted	
3/24/2022	2	Mudflat survey	NA	NA	NA	MF10	1.40730008	103.977543	15	0800-1200	<i>Anomalidolcus squamatus</i>	9	Seen	MF10_15m_270052	Targeted	Juvt
3/24/2022	2	Mudflat survey	NA	NA	NA	MF10	1.40730008	103.977543	15	0800-1200	<i>Tellina</i> sp.	2	Seen	MF10_15m_270052.53, 67.59	Targeted	
3/24/2022	2	Mudflat survey	NA	NA	NA	MF10	1.40730008	103.977543	15	0800-1200	<i>Nassarius pulcher</i>	1	Seen	MF10_15m_270075-77	Targeted	
3/24/2022	2	Mudflat survey	NA	NA	NA	MF10	1.40730008	103.977543	15	0800-1200	<i>Nerita bellulata</i>	1	Seen	MF10_15m_270036-37	Targeted	
3/24/2022	2	Mudflat survey	NA	NA	NA	MF10	1.40730008	103.977543	15	0800-1200	Family Ostreidae	1	Seen	MF10_15m_270080-81	Targeted	
3/24/2022	2	Mudflat survey	NA	NA	NA	MF10	1.40730008	103.977543	15	0800-1200	Family Phoridae	1	Seen		Targeted	
3/24/2022	2	Mudflat survey	NA	NA	NA	MF10	1.40730008	103.977543	15	0800-1200	<i>Tellina</i> sp.	2	Seen	MF10_15m_270049.56	Targeted	
3/24/2022	2	Mudflat survey	NA	NA	NA	MF10	1.40730008	103.977543	15	0800-1200	<i>Placamen chirovotum</i>	2	Seen	MF10_15m_270038	Targeted	
3/24/2022	2	Mudflat survey	NA	NA	NA	MF10	1.40730008	103.977543	15	0800-1200	<i>Diplodonta</i> sp.	2	Seen	MF10_15m_270068	Targeted	
3/24/2022	2	Mudflat survey	NA	NA	NA	MF10	1.40730008	103.977543	15	0800-1200	<i>Androsia ambigua</i>	1	Seen	MF10_15m_27009-40	Targeted	
3/24/2022	2	Mudflat survey	NA	NA	NA	MF10	1.40730008	103.977543	15	0800-1200	<i>Euchelus asper</i>	2	Seen	MF10_15m_270062	Targeted	
3/24/2022	2	Mudflat survey	NA	NA	NA	MF10	1.40730008	103.977543	15	0800-1200	<i>Ulva</i> sp.	2%	Seen	MF10_15m_270045	Targeted	
3/24/2022	2	Mudflat survey	NA	NA	NA	MF10	1.40730008	103.977543	15	0800-1200	<i>Ulva</i> sp.	2	Seen	MF10_15m_270043-44	Targeted	Word links visible on ventral picture
3/24/2022	2	Mudflat survey	NA	NA	NA	MF10	1.40730008	103.977543	15	0800-1200	<i>Nassarius olivaceus</i>	1	Seen	MF10_15m_270075-77	Targeted	Specimen degraded
3/24/2022	2	Mudflat survey	NA	NA	NA	MF10	1.40730008	103.977543	1	0800-1200	<i>Anomalidolcus squamatus</i>	50	Seen	Z1120	Targeted	
3/24/2022	2	Mudflat survey	NA	NA	NA	MF10	1.40730008	103.977543	1	0800-1200	<i>Balanus rotundus</i>	1	Seen	Z1140-1143, 1123, 1124, 1149	Targeted	
3/24/2022	2	Mudflat survey	NA	NA	NA	MF10	1.40730008	103.977543	1	0800-1200	<i>Balanus trigranulatus</i>	1	Seen		Targeted	
3/24/2022	2	Mudflat survey	NA	NA	NA	MF10	1.40730008	103.977543	1	0800-1200	<i>Balanus zanzibaricus</i>	1	Seen	Z1133	Targeted	
3/24/2022	2	Mudflat survey	NA	NA	NA	MF10	1.40730008	103.977543	1	0800-1200	<i>Phyllidia</i>	4%	Seen	Z1131	Targeted	
3/24/2022	2	Mudflat survey	NA	NA	NA	MF10	1.40730008	103.977543	1	0800-1200	<i>Caecum</i> sp.	1	Seen	Z1170-1171	Targeted	Degraded specimen
3/24/2022	2	Mudflat survey	NA	NA	NA	MF10	1.40730008	103.977543	1	0800-1200	<i>Phorellia</i> sp.	1	Seen	Z1134	Targeted	Degraded specimen
3/24/2022	2	Mudflat survey	NA	NA	NA	MF10	1.40730008	103.977543	1	0800-1200	<i>Chaetomorpha</i> sp.	1	Seen	Z1121	Targeted	
3/24/2022	2	Mudflat survey	NA	NA	NA	MF10	1.40730008	103.977543	1	0800-1200	<i>Mitrella brookeri</i>	1%	Seen	Z1128-1129	Targeted	1 juvenile
3/24/2022	2	Mudflat survey	NA	NA	NA	MF10	1.40730008	103.977543	1	0800-1200	<i>Verrillium granulosum</i>	1	Seen	Z1128, 1130-1131	Targeted	
3/24/2022	2	Mudflat survey	NA	NA	NA	MF10	1.40730008	103.977543	1	0800-1200	<i>Balanus</i> sp.	1	Seen	Z1149-1150	Targeted	
3/24/2022	2	Mudflat survey	NA	NA	NA	MF10	1.40730008	103.977543	1	0800-1200	<i>Coccidia horridula</i>	5	Seen	Z1149-1150	Targeted	
3/24/2022	2	Mudflat survey	NA	NA	NA	MF10	1.40730008	103.977543	1	0800-1200	<i>cf. Truncatella acuminata</i>	2	Seen	Z1172-1174	Targeted	
3/24/2022	2	Mudflat survey	NA	NA	NA	MF10	1.40730008	103.977543	1	0800-1200	Family Limulidae	1	Seen	Z1034.1035	Targeted	
3/24/2022	2	Mudflat survey	NA	NA	NA	MF10	1.40730008	103.977543	1	0800-1200	<i>Ostrea fida</i>	2,3	Seen	Z1144	Targeted	
3/24/2022	2	Mudflat survey	NA	NA	NA	MF10	1.40730008	103.977543	1	0800-1200	<i>Placamen chirovotum</i>	6	Seen	Z1136-1137	Targeted	
3/24/2022	2	Mudflat survey	NA	NA	NA	MF10	1.40730008	103.977543	1	0800-1200	<i>Austroliella corrugata</i>	1	Seen	MSC0136, Placamen chirovotum Austroliella corrugata	Targeted	
3/24/2022	2	Mudflat survey	NA	NA	NA	MF10	1.40730008	103.977543	1	0800-1200	<i>Pilax</i> sp.	3	Seen	Z1163-1164	Targeted	
3/24/2022	2	Mudflat survey	NA	NA	NA	MF10	1.40730008	103.977543	1	0800-1200	<i>Corbula</i> sp.	2	Seen	Z1126-1127	Targeted	Droplet
3/24/2022	2	Mudflat survey	NA	NA	NA	MF10	1.40730008	103.977543	1	0800-1200	<i>Placamen chirovotum</i>	4	Seen	Z1138-1139, 1109-1111	Targeted	
3/24/2022	2	Mudflat survey	NA	NA	NA	MF10	1.40730008	103.977543	1	0800-1200	<i>Polysiphonia</i>	1	Seen	Z1033, 27037	Targeted	
3/24/2022	2	Mudflat survey	NA	NA	NA	MF10	1.40730008	103.977543	1	0800-1200	<i>Epilobium</i> sp. 1	2	Seen	Z1164-1166	Targeted	
3/24/2022	2	Mudflat survey	NA	NA	NA	MF10	1.40730008	103.977543	1	0800-1200	<i>Selen</i> sp.	1	Seen	Z1125	Targeted	
3/24/2022	2	Mudflat survey	NA	NA	NA	MF10	1.40730008	103.977543	1	0800-1200	<i>Coccolithus horridula</i>	1	Seen	Z1134-1148	Targeted	
3/24/2022	2	Mudflat survey	NA	NA	NA	MF10	1.40730008	103.977543	1	0800-1200	<i>Tegulicera</i> sp.	22	Seen	Z1122	Targeted	
3/24/2022	2	Mudflat survey	NA	NA	NA	MF10	1.40730008	103.977543	1	0800-1200	<i>Mitrella fida</i>	1	Seen	Z1162	Targeted	
3/24/2022	2	Mudflat survey	NA	NA	NA	MF10	1.40730008	103.977543	1	0800-1200	<i>Ulva</i> sp.	13%	Seen	Z1121	Targeted	
3/24/2022	2	Mudflat survey	NA	NA	NA	MF10	1.40730008	103.977543	1	0800-1200	<i>Nassarius jacksonianus</i>	1	Seen	Z1117-1118	Targeted	
3/24/2022	2	Mudflat survey	NA	NA	NA	MF10	1.40730008	103.977543	5	0800-1200	<i>Anomalidolcus squamatus</i>	66	Seen		Targeted	
3/24/2022	2	Mudflat survey	NA	NA	NA	MF10	1.40730008	103.977543	5	0800-1200	<i>Balanus zanzibaricus</i>	2	Seen		Targeted	
3/24/2022	2	Mudflat survey	NA	NA	NA	MF10	1.40730008	103.977543	5	0800-1200	<i>Chaetomorpha</i> sp.	2%	Seen		Targeted	
3/24/2022	2	Mudflat survey	NA	NA	NA	MF10	1.40730008	103.977543	5	0800-1200	<i>Circa scripta</i>	1	Seen	Z11177	Targeted	
3/24/2022	2	Mudflat survey	NA	NA	NA	MF10	1.40730008	103.977543	5	0800-1200	<i>Austroliella corrugata</i>	2	Seen			

Date	Cycle	Route	Waypoint	Latitude	Longitude	Sampling point	Latitude	Longitude	Quadrat	Time (24h)	Scientific name	Quantity	Observation type (seen/heard/caught/sat/other signs)	Photo no.	Survey method (targeted/incidental/point count/trapping)	Remarks
3/25/2022	2	Mudflat survey	NA	NA	NA	MF07	1 40865018	103 978053	15	0800-1200	<i>Pisicampus chirocentrum</i>	1	Seen	MF07_15m_2118-119	Targeted	
3/25/2022	2	Mudflat survey	NA	NA	NA	MF07	1 40865018	103 978053	15	0800-1200	<i>Pisicampus</i>	1	Seen	MF07_15m_2106-65	Targeted	
3/25/2022	2	Mudflat survey	NA	NA	NA	MF07	1 40865018	103 978053	15	0800-1200	<i>Polydora</i>	1	Seen		Targeted	
3/25/2022	2	Mudflat survey	NA	NA	NA	MF07	1 40865018	103 978053	15	0800-1200	<i>Solea</i>	1	Seen		Targeted	Footprints
3/25/2022	2	Mudflat survey	NA	NA	NA	MF07	1 40865018	103 978053	15	0800-1200	<i>Fagularia nodiflora</i>	15	Seen	MF07_15m_21048	Targeted	
3/25/2022	2	Mudflat survey	NA	NA	NA	MF07	1 40865018	103 978053	15	0800-1200	<i>Anomalodiscus squamosus</i>	4	Seen		Targeted	
3/25/2022	2	Mudflat survey	NA	NA	NA	MF07	1 40865018	103 978053	5	0800-1200	<i>Pireneia cingulata</i>	47	Seen		Targeted	
3/25/2022	2	Mudflat survey	NA	NA	NA	MF07	1 40865018	103 978053	5	0800-1200	<i>Pisicampus chirocentrum</i>	1	Seen	MF07_5m_21014-125	Targeted	
3/25/2022	2	Mudflat survey	NA	NA	NA	MF07	1 40865018	103 978053	5	0800-1200	<i>Fagularia nodiflora</i>	1	Seen		Targeted	
3/25/2022	2	Mudflat survey	NA	NA	NA	MF07	1 40865018	103 978053	5	0800-1200	<i>Ulva</i>	70%	Seen		Targeted	
3/25/2022	2	Mudflat survey	NA	NA	NA	MF07	1 40865018	103 978053	NA	0800-1200	<i>Alpheidae</i>	1	Seen	MF07_21004-44, 67-69	Incidental	
3/25/2022	2	Mudflat survey	NA	NA	NA	MF07	1 40865018	103 978053	NA	0800-1200	<i>Cariniscorpius rotundicauda</i>	1	Seen	MF07_21004-10	Incidental	
3/25/2022	2	Mudflat survey	NA	NA	NA	MF07	1 40865018	103 978053	NA	0800-1200	<i>Cyprinotus pediculus</i>	1	Seen		Incidental	
3/25/2022	2	Mudflat survey	NA	NA	NA	MF07	1 40865018	103 978053	NA	0800-1200	<i>Anguilla japonica</i>	2	Seen	MF07_21008-85	Incidental	
3/25/2022	2	Mudflat survey	NA	NA	NA	MF07	1 40865018	103 978053	NA	0800-1200	<i>Merita balthica</i>	1	Seen		Incidental	
3/25/2022	2	Mudflat survey	NA	NA	NA	MF07	1 40865018	103 978053	NA	0800-1200	<i>Family Syngnathidae</i>	1	Seen	no picture	Incidental	
3/25/2022	2	Mudflat survey	NA	NA	NA	MF07	1 40865018	103 978053	NA	0800-1200	<i>Telescopium telescopium</i>	1	Seen	MF07_21009	Incidental	
3/25/2022	2	Mudflat survey	NA	NA	NA	MF07	1 40865018	103 978053	NA	0800-1200	<i>Terebralia sulcata</i>	1	Seen	MF07_21009-100	Incidental	
3/25/2022	2	Mudflat survey	NA	NA	NA	MF02	1 40997607	103 978305	10	0800-1200	<i>Ophioliron brevicolum</i>	4	Seen		Targeted	
3/25/2022	2	Mudflat survey	NA	NA	NA	MF02	1 40997607	103 978305	15	0800-1200	<i>Meloides tuberculata</i>	1	Smc	MF09_210027-30, 34	Targeted	
3/25/2022	2	Mudflat survey	NA	NA	NA	MF02	1 40997607	103 978305	15	0800-1200	<i>Nepiliron villosulum</i>	8	Seen	MF09_210023-26	Targeted	
3/25/2022	2	Mudflat survey	NA	NA	NA	MF02	1 40997607	103 978305	NA	0800-1200	<i>Episcamnia wuellerstorfi</i>	1	Seen	MF09_210068-13	Incidental	
3/25/2022	2	Mudflat survey	NA	NA	NA	MF02	1 40997607	103 978305	NA	0800-1200	<i>Palaemonetes pugio</i>	1	Seen		Incidental	
3/29/2022	2	Seine Netting	NA	NA	NA	F_01	1 406964419	103 978471	NA	1000-1400	<i>Unidentified Larfish</i>	15	Seen	Seineing_210001-0011	Targeted	
3/29/2022	2	Seine Netting	NA	NA	NA	F_01	1 406964419	103 978471	NA	1000-1400	<i>Styrax sp. J</i>	1	Seen	Seineing_210001-0021	Targeted	
3/30/2022	2	Seine Netting	NA	NA	NA	F_02	1 407869978	103 978479	NA	1300-1500	<i>Unidentified fish</i>	5	Seen	RS1036-50	Incidental	
3/30/2022	2	Seine Netting	NA	NA	NA	F_02	1 407869978	103 978479	NA	1300-1500	<i>Dermogenys collettii</i>	1	Seen		Incidental	
3/30/2022	2	Seine Netting	NA	NA	NA	F_02	1 407869978	103 978479	NA	1300-1500	<i>Family Syngnathidae</i>	5	Seen		Incidental	
3/30/2022	2	Seine Netting	NA	NA	NA	F_02	1 407869978	103 978479	NA	1300-1500	<i>Alpheidae</i>	1	Seen	RS1029_31, 34-36	Incidental	(Brown) Pipefish ID-ed by ZF, no photo cannot ID to genus
3/30/2022	2	Mudflat survey	NA	NA	NA	MF06	1 40827134	103 977935	NA	1400-1700	<i>Alpheus</i>	2	Seen	MF06_210040-42	Incidental	
3/30/2022	2	Mudflat survey	NA	NA	NA	MF06	1 40827134	103 977935	11	1400-1700	<i>Anomalodiscus squamosus</i>	6	Seen		Targeted	
3/30/2022	2	Mudflat survey	NA	NA	NA	MF06	1 40827134	103 977935	11	1400-1700	<i>Bastilla zonalis</i>	1	Seen		Targeted	
3/30/2022	2	Mudflat survey	NA	NA	NA	MF06	1 40827134	103 977935	NA	1400-1700	<i>Cibicides longianus</i>	1	Seen	MF06_210035-37	Incidental	
3/30/2022	2	Mudflat survey	NA	NA	NA	MF06	1 40827134	103 977935	11	1400-1700	<i>Cilitho oostreiformis</i>	1	Seen		Targeted	
3/30/2022	2	Mudflat survey	NA	NA	NA	MF06	1 40827134	103 977935	11	1400-1700	<i>Modiolus</i>	4	Seen	MF06_210038-39	Incidental	
3/30/2022	2	Mudflat survey	NA	NA	NA	MF06	1 40827134	103 977935	11	1400-1700	<i>Ophioliron brevicolum</i>	5	Seen	MF06_11m_210033-34, v2	Targeted	
3/30/2022	2	Mudflat survey	NA	NA	NA	MF06	1 40827134	103 977935	11	1400-1700	<i>Modiolus</i>	1	Seen	MF06_11m_210033-34	Targeted	
3/30/2022	2	Mudflat survey	NA	NA	NA	MF06	1 40827134	103 977935	11	1400-1700	<i>Pireneia cingulata</i>	1	Smc	MF06_11m_210036-37, v2	Targeted	
3/30/2022	2	Mudflat survey	NA	NA	NA	MF06	1 40827134	103 977935	11	1400-1700	<i>Pisicampus</i>	1	Seen	MF06_11m_210035-40	Targeted	
3/30/2022	2	Mudflat survey	NA	NA	NA	MF06	1 40827134	103 977935	11	1400-1700	<i>Pisicampus chirocentrum</i>	1	Seen		Targeted	
3/30/2022	2	Mudflat survey	NA	NA	NA	MF06	1 40827134	103 977935	11	1400-1700	<i>Pisicampus</i>	1	Seen	MF06_11m_210021-22, 27-28	Targeted	
3/30/2022	2	Mudflat survey	NA	NA	NA	MF06	1 40827134	103 977935	11	1400-1700	<i>Pisicampus</i>	1	Seen	MF06_7m_210030	Targeted	
3/30/2022	2	Mudflat survey	NA	NA	NA	MF06	1 40827134	103 977935	11	1400-1700	<i>Ulva</i>	1%	Seen		Targeted	
3/30/2022	2	Mudflat survey	NA	NA	NA	MF06	1 40827134	103 977935	NA	1400-1700	<i>Acanthopagrus janthinopterus</i>	1	Seen	MF06_210031-34	Incidental	
3/30/2022	2	Mudflat survey	NA	NA	NA	MF06	1 40827134	103 977935	2	1400-1700	<i>Anomalodiscus squamosus</i>	37	Seen	MF06_7m_210083-84	Targeted	
3/30/2022	2	Mudflat survey	NA	NA	NA	MF06	1 40827134	103 977935	2	1400-1700	<i>Barbatia amygdalostomum</i>	1	Seen	MF06_7m_210102-105	Targeted	
3/30/2022	2	Mudflat survey	NA	NA	NA	MF06	1 40827134	103 977935	2	1400-1700	<i>Barbatia obliquata</i>	3	Seen	MF06_7m_210102-105	Targeted	
3/30/2022	2	Mudflat survey	NA	NA	NA	MF06	1 40827134	103 977935	2	1400-1700	<i>Bastilla zonalis</i>	2	Seen	MF06_7m_210117-18	Targeted	
3/30/2022	2	Mudflat survey	NA	NA	NA	MF06	1 40827134	103 977935	2	1400-1700	<i>Circus undulata</i>	1	Seen	MF06_7m_210110-12	Targeted	
3/30/2022	2	Mudflat survey	NA	NA	NA	MF06	1 40827134	103 977935	2	1400-1700	<i>Indothys gradilis</i>	1	Seen	MF06_7m_210085, 88-90	Targeted	
3/30/2022	2	Mudflat survey	NA	NA	NA	MF06	1 40827134	103 977935	2	1400-1700	<i>Ophioliron brevicolum</i>	46	Seen		Targeted	
3/30/2022	2	Mudflat survey	NA	NA	NA	MF06	1 40827134	103 977935	2	1400-1700	<i>Pireneia cingulata</i>	50	Seen	MF06_7m_210120-121	Targeted	
3/30/2022	2	Mudflat survey	NA	NA	NA	MF06	1 40827134	103 977935	2	1400-1700	<i>Pireneia micropora</i>	25	Seen	MF06_7m_210122-125	Targeted	
3/30/2022	2	Mudflat survey	NA	NA	NA	MF06	1 40827134	103 977935	2	1400-1700	<i>Pisicampus</i>	2	Seen	MF06_7m_210052-54	Targeted	
3/30/2022	2	Mudflat survey	NA	NA	NA	MF06	1 40827134	103 977935	2	1400-1700	<i>Pisicampus chirocentrum</i>	6	Seen	MF06_7m_210113	Targeted	
3/30/2022	2	Mudflat survey	NA	NA	NA	MF06	1 40827134	103 977935	2	1400-1700	<i>Pisicampus</i>	1	Seen		Targeted	
3/30/2022	2	Mudflat survey	NA	NA	NA	MF06	1 40827134	103 977935	2	1400-1700	<i>Anomalodiscus squamosus</i>	24	Seen	MF06_7m_210073-74	Targeted	
3/30/2022	2	Mudflat survey	NA	NA	NA	MF06	1 40827134	103 977935	7	1400-1700	<i>Barbatia obliquata</i>	1	Seen	MF06_7m_210023-25	Targeted	
3/30/2022	2	Mudflat survey	NA	NA	NA	MF06	1 40827134	103 977935	7	1400-1700	<i>Bastilla zonalis</i>	4	Seen	MF06_7m_210044-44	Targeted	
3/30/2022	2	Mudflat survey	NA	NA	NA	MF06	1 40827134	103 977935	7	1400-1700	<i>Ergasilus contracta</i>	1	Seen	MF06_7m_210049-50, v2	Targeted	
3/30/2022	2	Mudflat survey	NA	NA	NA	MF06	1 40827134	103 977935	7	1400-1700	<i>Ophioliron brevicolum</i>	65	Seen		Targeted	
3/30/2022	2	Mudflat survey	NA	NA	NA	MF06	1 40827134	103 977935	7	1400-1700	<i>Ophioliron brevicolum</i>	9	Seen	MF06_7m_210020	Targeted	
3/30/2022	2	Mudflat survey	NA	NA	NA	MF06	1 40827134	103 977935	7	1400-1700	<i>Pireneia cingulata</i>	1	Smc	MF06_7m_210026-31	Targeted	
3/30/2022	2	Mudflat survey	NA	NA	NA	MF06	1 40827134	103 977935	7	1400-1700	<i>Pireneia micropora</i>	49	Seen	MF06_7m_210056-60	Targeted	
3/30/2022	2	Mudflat survey	NA	NA	NA	MF06	1 40827134	103 977935	7	1400-1700	<i>Pisicampus</i>	1	Seen	MF06_7m_210083-85	Targeted	
3/30/2022	2	Mudflat survey	NA	NA	NA	MF06	1 40827134	103 977935	7	1400-1700	<i>Pisicampus chirocentrum</i>	1	Seen	MF06_7m_210029	Targeted	
3/30/2022	2	Mudflat survey	NA	NA	NA	MF06	1 40827134	103 977935	7	1400-1700	<i>Fagularia nodiflora</i>	1	Seen			

Date	Cycle	Route	Waypoint	Latitude	Longitude	Sampling point	Latitude	Longitude	Quadrat	Time (24h)	Scientific name	Quantity	Observation type (seen/heard/caught/seen/other signs)	Photo no.	Survey method (targeted/incidental/catchpoint count/trapping)	Remarks
1/3/2022	2	T1	NA	1.40792674	103.978434	NA	NA	NA	NA	20:05:56	Scotophilus kuhlii	NA	Bat detector	20220301_200556.wav	Targeted	
1/3/2022	2	T1	NA	1.40795691	103.978952	NA	NA	NA	NA	20:06:27	Scotophilus kuhlii	NA	Bat detector	20220301_200627.wav	Targeted	
1/3/2022	2	T1	NA	1.40799682	103.978425	NA	NA	NA	NA	20:05:13	Scotophilus kuhlii	NA	Bat detector	20220301_200513.wav	Targeted	
1/3/2022	2	T1	NA	1.40794662	103.978931	NA	NA	NA	NA	20:05:28	Scotophilus kuhlii	NA	Bat detector	20220301_200528.wav	Targeted	
1/3/2022	2	T1	NA	1.40799943	103.978712	NA	NA	NA	NA	20:08:14	Scotophilus kuhlii	NA	Bat detector	20220301_200814.wav	Targeted	
1/3/2022	2	T1	NA	1.40788292	103.978176	NA	NA	NA	NA	20:09:03	Scotophilus kuhlii	NA	Bat detector	20220301_200903.wav	Targeted	
1/3/2022	2	T1	NA	1.40782899	103.978976	NA	NA	NA	NA	20:10:26	Scotophilus kuhlii	NA	Bat detector	20220301_201026.wav	Targeted	
1/3/2022	2	T1	NA	1.40784148	103.978167	NA	NA	NA	NA	20:09:48	Scotophilus kuhlii	NA	Bat detector	20220301_200948.wav	Targeted	
1/3/2022	2	T1	NA	1.40794459	103.978324	NA	NA	NA	NA	20:07:22	Scotophilus kuhlii	NA	Bat detector	20220301_200722.wav	Targeted	
1/3/2022	2	T1	NA	1.40788292	103.978176	NA	NA	NA	NA	20:09:17	Saccolaimus saccolaimus	NA	Bat detector	20220301_200917.wav	Targeted	
1/3/2022	2	T1	NA	1.40782899	103.978976	NA	NA	NA	NA	20:10:29	Scotophilus kuhlii	NA	Bat detector	20220301_201029.wav	Targeted	
1/3/2022	2	T1	NA	1.40785438	103.978047	NA	NA	NA	NA	20:11:59	Scotophilus kuhlii	NA	Bat detector	20220301_201159.wav	Targeted	
1/3/2022	2	T1	NA	1.40785438	103.978047	NA	NA	NA	NA	20:11:44	Scotophilus kuhlii	NA	Bat detector	20220301_201144.wav	Targeted	
1/3/2022	2	T1	NA	1.40787627	103.978936	NA	NA	NA	NA	20:12:21	Scotophilus kuhlii	NA	Bat detector	20220301_201221.wav	Targeted	
1/3/2022	2	T1	NA	1.40784848	103.978067	NA	NA	NA	NA	20:12:43	Scotophilus kuhlii	NA	Bat detector	20220301_201243.wav	Targeted	
1/3/2022	2	T1	NA	1.40784205	103.9780139	NA	NA	NA	NA	20:13:14	Scotophilus kuhlii	NA	Bat detector	20220301_201314.wav	Targeted	
1/3/2022	2	T1	NA	1.40771064	103.9779368	NA	NA	NA	NA	20:13:59	Scotophilus kuhlii	NA	Bat detector	20220301_201359.wav	Targeted	
1/3/2022	2	T1	NA	1.40776159	103.977925	NA	NA	NA	NA	20:14:29	Scotophilus kuhlii	NA	Bat detector	20220301_201429.wav	Targeted	
1/3/2022	2	T1	NA	1.407771064	103.9779368	NA	NA	NA	NA	20:14:14	Scotophilus kuhlii	NA	Bat detector	20220301_201414.wav	Targeted	
1/3/2022	2	T1	NA	1.40776119	103.9779375	NA	NA	NA	NA	20:14:44	Scotophilus kuhlii	NA	Bat detector	20220301_201444.wav	Targeted	
1/3/2022	2	T1	NA	1.40773887	103.977816	NA	NA	NA	NA	20:15:56	Scotophilus kuhlii	NA	Bat detector	20220301_201556.wav	Targeted	
1/3/2022	2	T1	NA	1.40771976	103.9778344	NA	NA	NA	NA	20:16:15	Saccolaimus saccolaimus	NA	Bat detector	20220301_201615.wav	Targeted	
1/3/2022	2	T1	NA	1.40771976	103.9778344	NA	NA	NA	NA	20:16:15	Scotophilus kuhlii	NA	Bat detector	20220301_201615.wav	Targeted	
1/3/2022	2	T1	NA	1.40794662	103.977931	NA	NA	NA	NA	20:17:31	Scotophilus kuhlii	NA	Bat detector	20220301_201731.wav	Targeted	
1/3/2022	2	T1	NA	1.40788548	103.977584	NA	NA	NA	NA	20:18:52	Scotophilus kuhlii	NA	Bat detector	20220301_201852.wav	Targeted	
1/3/2022	2	T1	NA	1.40784892	103.9776055	NA	NA	NA	NA	20:19:50	Scotophilus kuhlii	NA	Bat detector	20220301_201950.wav	Targeted	
1/3/2022	2	T1	NA	1.40780038	103.9775841	NA	NA	NA	NA	20:21:15	Saccolaimus saccolaimus	NA	Bat detector	20220301_202115.wav	Targeted	
1/3/2022	2	T1	NA	1.40779998	103.9775803	NA	NA	NA	NA	20:21:08	Saccolaimus saccolaimus	NA	Bat detector	20220301_202108.wav	Targeted	
1/3/2022	2	T1	NA	1.40787269	103.977549	NA	NA	NA	NA	20:20:47	Saccolaimus saccolaimus	NA	Bat detector	20220301_202047.wav	Targeted	
1/3/2022	2	T1	NA	1.40784203	103.977534	NA	NA	NA	NA	20:22:03	Saccolaimus saccolaimus	NA	Bat detector	20220301_202203.wav	Targeted	
1/3/2022	2	T1	NA	1.40787852	103.977531	NA	NA	NA	NA	20:22:35	Scotophilus kuhlii	NA	Bat detector	20220301_202235.wav	Targeted	
1/3/2022	2	T1	NA	1.40780258	103.9775847	NA	NA	NA	NA	20:21:19	Saccolaimus saccolaimus	NA	Bat detector	20220301_202119.wav	Targeted	
1/3/2022	2	T1	NA	1.40784203	103.977534	NA	NA	NA	NA	20:21:52	Saccolaimus saccolaimus	NA	Bat detector	20220301_202152.wav	Targeted	
1/3/2022	2	T1	NA	1.40772144	103.9776049	NA	NA	NA	NA	20:20:20	Scotophilus kuhlii	NA	Bat detector	20220301_202020.wav	Targeted	
1/3/2022	2	T1	NA	1.40787852	103.977531	NA	NA	NA	NA	20:22:28	Scotophilus kuhlii	NA	Bat detector	20220301_202228.wav	Targeted	
1/3/2022	2	T1	NA	1.40824463	103.977531	NA	NA	NA	NA	20:22:07	Saccolaimus saccolaimus	NA	Bat detector	20220301_202207.wav	Targeted	
1/3/2022	2	T1	NA	1.40786293	103.977534	NA	NA	NA	NA	20:22:07	Scotophilus kuhlii	NA	Bat detector	20220301_202207.wav	Targeted	
1/3/2022	2	T1	NA	1.40801708	103.9774885	NA	NA	NA	NA	20:25:22	Saccolaimus saccolaimus	NA	Bat detector	20220301_202522.wav	Targeted	
1/3/2022	2	T1	NA	1.40786293	103.977534	NA	NA	NA	NA	20:24:27	Scotophilus kuhlii	NA	Bat detector	20220301_202427.wav	Targeted	
1/3/2022	2	T1	NA	1.40808241	103.977486	NA	NA	NA	NA	20:26:15	Scotophilus kuhlii	NA	Bat detector	20220301_202615.wav	Targeted	
1/3/2022	2	T1	NA	1.40801708	103.9774885	NA	NA	NA	NA	20:25:26	Saccolaimus saccolaimus	NA	Bat detector	20220301_202526.wav	Targeted	
1/3/2022	2	T1	NA	1.40786293	103.977534	NA	NA	NA	NA	20:25:06	Scotophilus kuhlii	NA	Bat detector	20220301_202506.wav	Targeted	
1/3/2022	2	T1	NA	1.40811034	103.9774342	NA	NA	NA	NA	20:27:35	Scotophilus kuhlii	NA	Bat detector	20220301_202735.wav	Targeted	
1/3/2022	2	T1	NA	1.40835444	103.9773824	NA	NA	NA	NA	20:29:20	Saccolaimus saccolaimus	NA	Bat detector	20220301_202920.wav	Targeted	
1/3/2022	2	T1	NA	1.40808241	103.977486	NA	NA	NA	NA	20:26:27	Scotophilus kuhlii	NA	Bat detector	20220301_202627.wav	Targeted	
1/3/2022	2	T1	NA	1.40807609	103.9774657	NA	NA	NA	NA	20:25:56	Scotophilus kuhlii	NA	Bat detector	20220301_202556.wav	Targeted	
1/3/2022	2	T1	NA	1.408205163	103.9774458	NA	NA	NA	NA	20:28:11	Scotophilus kuhlii	NA	Bat detector	20220301_202811.wav	Targeted	
1/3/2022	2	T1	NA	1.408386128	103.977416	NA	NA	NA	NA	20:31:22	Saccolaimus saccolaimus	NA	Bat detector	20220301_203122.wav	Targeted	
1/3/2022	2	T1	NA	1.40839747	103.977424	NA	NA	NA	NA	20:31:36	Scotophilus kuhlii	NA	Bat detector	20220301_203136.wav	Targeted	
1/3/2022	2	T1	NA	1.40839275	103.9774093	NA	NA	NA	NA	20:32:19	Saccolaimus saccolaimus	NA	Bat detector	20220301_203219.wav	Targeted	
1/3/2022	2	T1	NA	1.40842039	103.9774174	NA	NA	NA	NA	20:33:06	Scotophilus kuhlii	NA	Bat detector	20220301_203306.wav	Targeted	
1/3/2022	2	T1	NA	1.40843242	103.9773929	NA	NA	NA	NA	20:33:40	Scotophilus kuhlii	NA	Bat detector	20220301_203340.wav	Targeted	
1/3/2022	2	T1	NA	1.408458799	103.9773929	NA	NA	NA	NA	20:33:52	Scotophilus kuhlii	NA	Bat detector	20220301_203352.wav	Targeted	
1/3/2022	2	T1	NA	1.40842039	103.9774174	NA	NA	NA	NA	20:33:14	Scotophilus kuhlii	NA	Bat detector	20220301_203314.wav	Targeted	
1/3/2022	2	T1	NA	1.408458799	103.9773929	NA	NA	NA	NA	20:35:05	Saccolaimus saccolaimus	NA	Bat detector	20220301_203505.wav	Targeted	
1/3/2022	2	T1	NA	1.4085883	103.9773598	NA	NA	NA	NA	20:35:34	Scotophilus kuhlii	NA	Bat detector	20220301_203534.wav	Targeted	
1/3/2022	2	T1	NA	1.40852571	103.977398	NA	NA	NA	NA	20:35:18	Saccolaimus saccolaimus	NA	Bat detector	20220301_203518.wav	Targeted	
1/3/2022	2	T1	NA	1.4085883	103.9773598	NA	NA	NA	NA	20:35:52	Scotophilus kuhlii	NA	Bat detector	20220301_203552.wav	Targeted	
1/3/2022	2	T1	NA	1.408458799	103.9773598	NA	NA	NA	NA	20:34:47	Saccolaimus saccolaimus	NA	Bat detector	20220301_203447.wav	Targeted	
1/3/2022	2	T1	NA	1.40852571	103.977398	NA	NA	NA	NA	20:35:24	Scotophilus kuhlii	NA	Bat detector	20220301_203524.wav	Targeted	
1/3/2022	2	T1	NA	1.4085883	103.9773598	NA	NA	NA	NA	20:35:39	Scotophilus kuhlii	NA	Bat detector	20220301_203539.wav	Targeted	
1/3/2022	2	T1	NA	1.40856039	103.9773403	NA	NA	NA	NA	20:36:07	Saccolaimus saccolaimus	NA	Bat detector	20220301_203607.wav	Targeted	
1/3/2022	2	T1	NA	1.40842445	103.9773853	NA	NA	NA	NA	20:36:21	Scotophilus kuhlii	NA	Bat detector	20220301_203621.wav	Targeted	
1/3/2022	2	T1	NA	1.408723248	103.9773099	NA	NA	NA	NA	20:37:13	Scotophilus kuhlii	NA	Bat detector	20220301_203713.wav	Targeted	
1/3/2022	2	T1	NA	1.408842104	103.9771739	NA	NA	NA	NA	20:40:16	Saccolaimus saccolaimus	NA	Bat detector	20220301_204016.wav	Targeted	
1/3/2022	2	T1	NA	1.40883668	103.9772163	NA	NA	NA	NA	20:39:48	Saccolaimus saccolaimus	NA	Bat detector	20220301_203948.wav	Targeted	
1/3/2022	2	T1	NA	1.40856039	103.9773403	NA	NA	NA	NA	20:36:13	Saccolaimus saccolaimus	NA	Bat detector	20220301_203613.wav	Targeted	
1/3/2022	2	T1	NA	1.408842104	103.9771739	NA	NA	NA	NA	20:40:01	Saccolaimus saccolaimus	NA	Bat detector	20220301_204001.wav	Targeted	
1/3/2022	2	T1	NA	1.40890349	103.9771132	NA	NA	NA	NA	20:40:40	Saccolaimus saccolaimus	NA	Bat detector	20220301_204040.wav	Targeted	
1/3/2022	2	T1	NA	1.40891965	103.977083	NA	NA	NA	NA	20:41:21	Scotophilus kuhlii	NA	Bat detector	20220301_204121.wav	Targeted	
1/3/2022	2	T1	NA	1.40891965	103.977083	NA	NA	NA	NA	20:41:25	Saccolaimus saccolaimus	NA	Bat detector	20220301_204125.wav	Targeted	
1/3/2022	2	T1	NA	1.40894785	103.977088	NA	NA	NA	NA	20:41:38	Saccolaimus saccolaimus	NA	Bat detector	20220301_204138.wav	Targeted	
1/3/2022	2	T1	NA	1.40893715	103.977088	NA	NA	NA	NA	20:41:38	Saccolaimus saccolaimus	NA	Bat detector	20220301_204138.wav	Targeted	
1/3/2022	2	T1	NA	1.40890459	103.9771123	NA	NA	NA	NA	20:40:31	Saccolaimus saccolaimus	NA	Bat detector	20220301_204031.wav	Targeted	
1/3/2022	2	T1	NA	1.40893715	103.977088	NA	NA	NA	NA	20:41:49	Saccolaimus saccolaimus	NA	Bat detector	20220301_204149.wav	Targeted	
1/3/2022	2	T1	NA	1.40893715	103.9770											

Date	Cycle	Route	Waypoint	Latitude	Longitude	Sampling point	Latitude	Longitude	Quadrat	Time (24h)	Scientific name	Quantity	Observation type (seen/heard/caught/sat/other signs)	Photo no.	Survey method (targeted/incidental/point count/trapping)	Remarks
1/3/2022	2	T1	NA	1.40867395	103.9760213	NA	NA	NA	NA	21:06:24	Saccolaimus saccolaimus	NA	Bat detector	20220301_210624.wav	Targeted	
1/3/2022	2	T1	NA	1.40872268	103.975746	NA	NA	NA	NA	21:07:27	Saccolaimus saccolaimus	NA	Bat detector	20220301_210727.wav	Targeted	
1/3/2022	2	T1	NA	1.40872387	103.975781	NA	NA	NA	NA	21:08:29	Saccolaimus saccolaimus	NA	Bat detector	20220301_210829.wav	Targeted	
1/3/2022	2	T1	NA	1.40867395	103.9760213	NA	NA	NA	NA	21:06:33	Saccolaimus saccolaimus	NA	Bat detector	20220301_210633.wav	Targeted	
1/3/2022	2	T1	NA	1.40871726	103.975782	NA	NA	NA	NA	21:09:13	Saccolaimus saccolaimus	NA	Bat detector	20220301_210913.wav	Targeted	
1/3/2022	2	T1	NA	1.40869957	103.975787	NA	NA	NA	NA	21:07:43	Saccolaimus saccolaimus	NA	Bat detector	20220301_210743.wav	Targeted	
1/3/2022	2	T1	NA	1.40873287	103.975781	NA	NA	NA	NA	21:08:34	Saccolaimus saccolaimus	NA	Bat detector	20220301_210834.wav	Targeted	
1/3/2022	2	T1	NA	1.40878158	103.975787	NA	NA	NA	NA	21:08:44	Saccolaimus saccolaimus	NA	Bat detector	20220301_210844.wav	Targeted	
1/3/2022	2	T1	NA	1.40871726	103.975782	NA	NA	NA	NA	21:09:20	Saccolaimus saccolaimus	NA	Bat detector	20220301_210920.wav	Targeted	
1/3/2022	2	T1	NA	1.40866258	103.9758187	NA	NA	NA	NA	21:12:48	Saccolaimus saccolaimus	NA	Bat detector	20220301_211248.wav	Targeted	
1/3/2022	2	T1	NA	1.40868426	103.975784	NA	NA	NA	NA	21:10:29	Saccolaimus saccolaimus	NA	Bat detector	20220301_211029.wav	Targeted	
1/3/2022	2	T1	NA	1.40869015	103.975787	NA	NA	NA	NA	21:10:57	Saccolaimus saccolaimus	NA	Bat detector	20220301_211057.wav	Targeted	
1/3/2022	2	T1	NA	1.40868426	103.9754133	NA	NA	NA	NA	21:19:23	Saccolaimus saccolaimus	NA	Bat detector	20220301_211923.wav	Targeted	
1/3/2022	2	T1	NA	1.40869027	103.975721	NA	NA	NA	NA	21:21:58	Scotophilus kuhlii	NA	Bat detector	20220301_212158.wav	Targeted	
1/3/2022	2	T1	NA	1.40864373	103.975746	NA	NA	NA	NA	21:22:39	Scotophilus kuhlii	NA	Bat detector	20220301_212239.wav	Targeted	
1/3/2022	2	T1	NA	1.40866258	103.9758187	NA	NA	NA	NA	21:12:29	Saccolaimus saccolaimus	NA	Bat detector	20220301_211229.wav	Targeted	
1/3/2022	2	T1	NA	1.408656281	103.975641	NA	NA	NA	NA	21:22:38	Scotophilus kuhlii	NA	Bat detector	20220301_212238.wav	Targeted	
1/3/2022	2	T1	NA	1.408699142	103.975624	NA	NA	NA	NA	21:25:58	Scotophilus kuhlii	NA	Bat detector	20220301_212558.wav	Targeted	
1/3/2022	2	T1	NA	1.40813224	103.9756203	NA	NA	NA	NA	21:28:12	Scotophilus kuhlii	NA	Bat detector	20220301_212812.wav	Targeted	
1/3/2022	2	T1	NA	1.408699142	103.975624	NA	NA	NA	NA	21:26:06	Scotophilus kuhlii	NA	Bat detector	20220301_212606.wav	Targeted	
1/3/2022	2	T1	NA	1.40893097	103.975645	NA	NA	NA	NA	21:28:16	Scotophilus kuhlii	NA	Bat detector	20220301_212816.wav	Targeted	
1/3/2022	2	T1	NA	1.40808287	103.9756494	NA	NA	NA	NA	21:33:22	Scotophilus kuhlii	NA	Bat detector	20220301_213322.wav	Targeted	
1/3/2022	2	T1	NA	1.40861586	103.975621	NA	NA	NA	NA	21:27:15	Scotophilus kuhlii	NA	Bat detector	20220301_212715.wav	Targeted	
1/3/2022	2	T1	NA	1.40892487	103.975694	NA	NA	NA	NA	21:33:09	Scotophilus kuhlii	NA	Bat detector	20220301_213309.wav	Targeted	
1/3/2022	2	T1	NA	1.40815168	103.9756217	NA	NA	NA	NA	21:27:34	Scotophilus kuhlii	NA	Bat detector	20220301_212734.wav	Targeted	
1/3/2022	2	T1	NA	1.40808857	103.975734	NA	NA	NA	NA	21:34:53	Saccolaimus saccolaimus	NA	Bat detector	20220301_213453.wav	Targeted	
1/3/2022	2	T1	NA	1.40809628	103.975694	NA	NA	NA	NA	21:35:44	Scotophilus kuhlii	NA	Bat detector	20220301_213544.wav	Targeted	
1/3/2022	2	T1	NA	1.40808857	103.975734	NA	NA	NA	NA	21:34:58	Saccolaimus saccolaimus	NA	Bat detector	20220301_213458.wav	Targeted	
1/3/2022	2	T1	NA	1.40808857	103.975734	NA	NA	NA	NA	21:35:05	Scotophilus kuhlii	NA	Bat detector	20220301_213505.wav	Targeted	
1/3/2022	2	T1	NA	1.40805616	103.975734	NA	NA	NA	NA	21:36:15	Scotophilus kuhlii	NA	Bat detector	20220301_213615.wav	Targeted	
1/3/2022	2	T1	NA	1.40809628	103.975694	NA	NA	NA	NA	21:35:49	Scotophilus kuhlii	NA	Bat detector	20220301_213549.wav	Targeted	
1/3/2022	2	T1	NA	1.40808291	103.9757074	NA	NA	NA	NA	21:36:37	Scotophilus kuhlii	NA	Bat detector	20220301_213637.wav	Targeted	
1/3/2022	2	T1	NA	1.40770249	103.9758882	NA	NA	NA	NA	21:44:50	Saccolaimus saccolaimus	NA	Bat detector	20220301_214450.wav	Targeted	
1/3/2022	2	T1	NA	1.40768439	103.975828	NA	NA	NA	NA	21:45:08	Scotophilus kuhlii	NA	Bat detector	20220301_214508.wav	Targeted	
1/3/2022	2	T1	NA	1.40796508	103.9757623	NA	NA	NA	NA	21:39:09	Saccolaimus saccolaimus	NA	Bat detector	20220301_213909.wav	Targeted	
1/3/2022	2	T1	NA	1.40809628	103.975828	NA	NA	NA	NA	20:59:56	Scotophilus kuhlii	NA	Bat detector	20220301_205956.wav	Targeted	
1/3/2022	2	T2	NA	1.40809634	103.978892	NA	NA	NA	NA	20:10:02	Saccolaimus saccolaimus	NA	Bat detector	20220301_201002.wav	Targeted	
1/3/2022	2	T2	NA	1.40808521	103.978925	NA	NA	NA	NA	20:10:36	Scotophilus kuhlii	NA	Bat detector	20220301_201036.wav	Targeted	
1/3/2022	2	T2	NA	1.40804482	103.978959	NA	NA	NA	NA	20:11:03	Saccolaimus saccolaimus	NA	Bat detector	20220301_201103.wav	Targeted	
1/3/2022	2	T2	NA	1.40807261	103.978954	NA	NA	NA	NA	20:10:25	Saccolaimus saccolaimus	NA	Bat detector	20220301_201025.wav	Targeted	
1/3/2022	2	T2	NA	1.4080521	103.978925	NA	NA	NA	NA	20:10:47	Saccolaimus saccolaimus	NA	Bat detector	20220301_201047.wav	Targeted	
1/3/2022	2	T2	NA	1.40805849	103.9788848	NA	NA	NA	NA	20:11:47	Saccolaimus saccolaimus	NA	Bat detector	20220301_201147.wav	Targeted	
1/3/2022	2	T2	NA	1.40805849	103.9788848	NA	NA	NA	NA	20:11:47	Scotophilus kuhlii	NA	Bat detector	20220301_201147.wav	Targeted	
1/3/2022	2	T2	NA	1.40805849	103.9788848	NA	NA	NA	NA	20:11:25	Saccolaimus saccolaimus	NA	Bat detector	20220301_201125.wav	Targeted	
1/3/2022	2	T2	NA	1.40805849	103.9788848	NA	NA	NA	NA	20:11:25	Scotophilus kuhlii	NA	Bat detector	20220301_201125.wav	Targeted	
1/3/2022	2	T2	NA	1.40805849	103.9788848	NA	NA	NA	NA	20:11:36	Saccolaimus saccolaimus	NA	Bat detector	20220301_201136.wav	Targeted	
1/3/2022	2	T2	NA	1.40805849	103.9788848	NA	NA	NA	NA	20:11:36	Scotophilus kuhlii	NA	Bat detector	20220301_201136.wav	Targeted	
1/3/2022	2	T2	NA	1.408061581	103.9788427	NA	NA	NA	NA	20:11:53	Saccolaimus saccolaimus	NA	Bat detector	20220301_201153.wav	Targeted	
1/3/2022	2	T2	NA	1.40801043	103.978758	NA	NA	NA	NA	20:12:56	Scotophilus kuhlii	NA	Bat detector	20220301_201256.wav	Targeted	
1/3/2022	2	T2	NA	1.40824248	103.978923	NA	NA	NA	NA	20:13:43	Taphous melanocephalus	NA	Bat detector	20220301_201343.wav	Targeted	
1/3/2022	2	T2	NA	1.408061581	103.9788427	NA	NA	NA	NA	20:12:05	Taphous melanocephalus	NA	Bat detector	20220301_201205.wav	Targeted	
1/3/2022	2	T2	NA	1.408061581	103.9788427	NA	NA	NA	NA	20:12:05	Scotophilus kuhlii	NA	Bat detector	20220301_201205.wav	Targeted	
1/3/2022	2	T2	NA	1.408061581	103.9788427	NA	NA	NA	NA	20:12:05	Saccolaimus saccolaimus	NA	Bat detector	20220301_201205.wav	Targeted	
1/3/2022	2	T2	NA	1.40807261	103.978954	NA	NA	NA	NA	20:10:09	Scotophilus kuhlii	NA	Bat detector	20220301_201009.wav	Targeted	
1/3/2022	2	T2	NA	1.408061581	103.9788427	NA	NA	NA	NA	20:10:09	Saccolaimus saccolaimus	NA	Bat detector	20220301_201009.wav	Targeted	
1/3/2022	2	T2	NA	1.408061581	103.9788427	NA	NA	NA	NA	20:10:09	Scotophilus kuhlii	NA	Bat detector	20220301_201009.wav	Targeted	
1/3/2022	2	T2	NA	1.408061581	103.9788427	NA	NA	NA	NA	20:10:09	Saccolaimus saccolaimus	NA	Bat detector	20220301_201009.wav	Targeted	
1/3/2022	2	T2	NA	1.40807261	103.978954	NA	NA	NA	NA	20:10:09	Scotophilus kuhlii	NA	Bat detector	20220301_201009.wav	Targeted	
1/3/2022	2	T2	NA	1.40807261	103.978954	NA	NA	NA	NA	20:10:09	Saccolaimus saccolaimus	NA	Bat detector	20220301_201009.wav	Targeted	
1/3/2022	2	T2	NA	1.40807261	103.978954	NA	NA	NA	NA	20:10:09	Scotophilus kuhlii	NA	Bat detector	20220301_201009.wav	Targeted	
1/3/2022	2	T2	NA	1.40807261	103.978954	NA	NA	NA	NA	20:10:09	Saccolaimus saccolaimus	NA	Bat detector	20220301_201009.wav	Targeted	
1/3/2022	2	T2	NA	1.40807261	103.978954	NA	NA	NA	NA	20:10:09	Scotophilus kuhlii	NA	Bat detector	20220301_201009.wav	Targeted	
1/3/2022	2	T2	NA	1.40807261	103.978954	NA	NA	NA	NA	20:10:09	Saccolaimus saccolaimus	NA	Bat detector	20220301_201009.wav	Targeted	
1/3/2022	2	T2	NA	1.40807261	103.978954	NA	NA	NA	NA	20:10:09	Scotophilus kuhlii	NA	Bat detector	20220301_201009.wav	Targeted	
1/3/2022	2	T2	NA	1.40807261	103.978954	NA	NA	NA	NA	20:10:09	Saccolaimus saccolaimus	NA	Bat detector	20220301_201009.wav	Targeted	
1/3/2022	2	T2	NA	1.40807261	103.978954	NA	NA	NA	NA	20:10:09	Scotophilus kuhlii	NA	Bat detector	20220301_201009.wav	Targeted	
1/3/2022	2	T2	NA	1.40807261	103.978954	NA	NA	NA	NA	20:10:09	Saccolaimus saccolaimus	NA	Bat detector	20220301_201009.wav	Targeted	
1/3/2022	2	T2	NA	1.40807261	103.978954	NA	NA	NA	NA	20:10:09	Scotophilus kuhlii	NA	Bat detector	20220301_201009.wav	Targeted	
1/3/2022	2	T2	NA	1.40807261	103.978954	NA	NA	NA	NA	20:10:09	Saccolaimus saccolaimus	NA	Bat detector	20220301_201009.wav	Targeted	
1/3/2022	2	T2	NA	1.40807261	103.978954	NA	NA	NA	NA	20:10:09	Scotophilus kuhlii	NA	Bat detector	20220301_201009.wav	Targeted	
1/3/2022	2	T2	NA	1.40807261	103.978954	NA	NA	NA	NA	20:10:09	Saccolaimus saccolaimus	NA	Bat detector	20220301_201009.wav	Targeted	
1/3/2022	2	T2	NA	1.40807261	103.978954	NA	NA	NA	NA	20:10:09	Scotophilus kuhlii	NA	Bat detector	20220301_201009.wav	Targeted	
1/3/2022	2	T2	NA	1.40807261	103.978954	NA	NA	NA	NA	20:10:09	Saccolaimus saccolaimus	NA	Bat detector	20220301_201009.wav	Targeted	
1/3/2022	2	T2	NA	1.40807261	103.978954	NA	NA	NA	NA	20:10:09	Scotophilus kuhlii	NA	Bat detector	20220301_201009.wav	Targeted	
1/3/2022	2	T2	NA	1.40807261	103.978954	NA	NA	NA	NA	20:10:09	Saccolaimus saccolaimus	NA	Bat detector	20220301_201009.wav		

Appendix G Camera Trap Data

Pulau Ubin Durian Appendix G - Camera Trap Data

20220329	CT02	1.40779403	103.975974	2022-03-02	22:55:36	IMG_0086.AVI	<i>Tragulus napu</i>	1	Greater mousedeer	Mammal	Least Concern	Critically Endangered	Yes	Critically Endangered	NA
20220329	CT02	1.40779403	103.975974	2022-03-02	22:55:58	IMG_0087.AVI	<i>Tragulus napu</i>	1	Greater mousedeer	Mammal	Least Concern	Critically Endangered	Yes	Critically Endangered	NA
20220329	CT02	1.40779403	103.975974	2022-02-27	4:51:20	IMG_0048.AVI	Unidentified Muridae	1	NA	Mammal	NA	NA	NA	NA	NA
20220329	CT02	1.40779403	103.975974	2022-02-27	6:27:36	IMG_0049.AVI	Unidentified Muridae	1	NA	Mammal	NA	NA	NA	NA	NA
20220329	CT02	1.40779403	103.975974	2022-02-23	20:10:36	IMG_0002.AVI	Unidentified Muridae	1	NA	Mammal	NA	NA	NA	NA	NA
20220329	CT02	1.40779403	103.975974	2022-02-24	20:52:40	IMG_0016.AVI	Unidentified Muridae	1	NA	Mammal	NA	NA	NA	NA	NA
20220329	CT02	1.40779403	103.975974	2022-02-24	0:16:56	IMG_0017.AVI	Unidentified Muridae	1	NA	Mammal	NA	NA	NA	NA	NA
20220329	CT02	1.40779403	103.975974	2022-02-24	3:24:58	IMG_0018.AVI	Unidentified Muridae	1	NA	Mammal	NA	NA	NA	NA	NA
20220329	CT02	1.40779403	103.975974	2022-02-25	0:21:10	IMG_0019.AVI	Unidentified Muridae	1	NA	Mammal	NA	NA	NA	NA	NA
20220329	CT02	1.40779403	103.975974	2022-02-25	4:34:34	IMG_0020.AVI	Unidentified Muridae	1	NA	Mammal	NA	NA	NA	NA	NA
20220329	CT02	1.40779403	103.975974	2022-02-26	21:41:20	IMG_0025.AVI	Unidentified Muridae	1	NA	Mammal	NA	NA	NA	NA	NA
20220329	CT02	1.40779403	103.975974	2022-02-27	21:23:46	IMG_0045.AVI	Unidentified Muridae	1	NA	Mammal	NA	NA	NA	NA	NA
20220329	CT02	1.40779403	103.975974	2022-02-28	22:31:42	IMG_0058.AVI	Unidentified Muridae	1	NA	Mammal	NA	NA	NA	NA	NA
20220329	CT02	1.40779403	103.975974	2022-02-28	3:24:06	IMG_0059.AVI	Unidentified Muridae	1	NA	Mammal	NA	NA	NA	NA	NA
20220329	CT02	1.40779403	103.975974	2022-03-01	20:21:54	IMG_0072.AVI	Unidentified Muridae	1	NA	Mammal	NA	NA	NA	NA	NA
20220329	CT02	1.40779403	103.975974	2022-03-01	23:50:44	IMG_0073.AVI	Unidentified Muridae	1	NA	Mammal	NA	NA	NA	NA	NA
20220329	CT02	1.40779403	103.975974	2022-03-01	0:04:58	IMG_0074.AVI	Unidentified Muridae	1	NA	Mammal	NA	NA	NA	NA	NA
20220329	CT02	1.40779403	103.975974	2022-03-01	1:07:30	IMG_0075.AVI	Unidentified Muridae	1	NA	Mammal	NA	NA	NA	NA	NA
20220329	CT02	1.40779403	103.975974	2022-03-02	19:56:00	IMG_0078.AVI	Unidentified Muridae	1	NA	Mammal	NA	NA	NA	NA	NA
20220329	CT02	1.40779403	103.975974	2022-03-02	21:21:32	IMG_0079.AVI	Unidentified Muridae	1	NA	Mammal	NA	NA	NA	NA	NA
20220329	CT02	1.40779403	103.975974	2022-03-02	22:46:30	IMG_0085.AVI	Unidentified Muridae	1	NA	Mammal	NA	NA	NA	NA	NA
20220329	CT02	1.40779403	103.975974	2022-03-02	23:26:24	IMG_0088.AVI	Unidentified Muridae	1	NA	Mammal	NA	NA	NA	NA	NA
20220329	CT02	1.40779403	103.975974	2022-03-02	0:36:42	IMG_0089.AVI	Unidentified Muridae	1	NA	Mammal	NA	NA	NA	NA	NA
20220329	CT02	1.40779403	103.975974	2022-03-02	5:56:26	IMG_0090.AVI	Unidentified Muridae	1	NA	Mammal	NA	NA	NA	NA	NA
20220329	CT02	1.40779403	103.975974	2022-03-03	0:35:36	IMG_0099.AVI	Unidentified Muridae	1	NA	Mammal	NA	NA	NA	NA	NA
20220329	CT02	1.40779403	103.975974	2022-03-03	2:24:04	IMG_0100.AVI	Unidentified Muridae	1	NA	Mammal	NA	NA	NA	NA	NA
20220329	CT02	1.40779403	103.975974	2022-03-05	23:27:36	IMG_0115.AVI	Unidentified Muridae	1	NA	Mammal	NA	NA	NA	NA	NA
20220329	CT02	1.40779403	103.975974	2022-03-06	2:37:02	IMG_0120.AVI	Unidentified Muridae	1	NA	Mammal	NA	NA	NA	NA	NA
20220329	CT02	1.40779403	103.975974	2022-03-06	5:52:44	IMG_0121.AVI	Unidentified Muridae	1	NA	Mammal	NA	NA	NA	NA	NA
20220329	CT02	1.40779403	103.975974	2022-03-07	23:23:24	IMG_0132.AVI	Unidentified Muridae	1	NA	Mammal	NA	NA	NA	NA	NA
20220329	CT02	1.40779403	103.975974	2022-03-07	0:21:40	IMG_0133.AVI	Unidentified Muridae	1	NA	Mammal	NA	NA	NA	NA	NA
20220329	CT02	1.40779403	103.975974	2022-03-08	23:52:16	IMG_0141.AVI	Unidentified Muridae	1	NA	Mammal	NA	NA	NA	NA	NA
20220329	CT02	1.40779403	103.975974	2022-03-09	2:30:18	IMG_0147.AVI	Unidentified Muridae	1	NA	Mammal	NA	NA	NA	NA	NA
20220329	CT02	1.40779403	103.975974	2022-03-10	21:00:00	IMG_0153.AVI	Unidentified Muridae	1	NA	Mammal	NA	NA	NA	NA	NA
20220329	CT02	1.40779403	103.975974	2022-03-11	20:58:30	IMG_0157.AVI	Unidentified Muridae	1	NA	Mammal	NA	NA	NA	NA	NA
20220329	CT02	1.40779403	103.975974	2022-03-11	23:48:24	IMG_0158.AVI	Unidentified Muridae	1	NA	Mammal	NA	NA	NA	NA	NA
20220329	CT02	1.40779403	103.975974	2022-03-11	2:18:48	IMG_0161.AVI	Unidentified Muridae	1	NA	Mammal	NA	NA	NA	NA	NA
20220329	CT02	1.40779403	103.975974	2022-03-11	4:00:40	IMG_0162.AVI	Unidentified Muridae	1	NA	Mammal	NA	NA	NA	NA	NA
20220329	CT02	1.40779403	103.975974	2022-03-12	1:09:28	IMG_0166.AVI	Unidentified Muridae	1	NA	Mammal	NA	NA	NA	NA	NA
20220329	CT02	1.40779403	103.975974	2022-03-12	2:17:48	IMG_0167.AVI	Unidentified Muridae	1	NA	Mammal	NA	NA	NA	NA	NA
20220329	CT02	1.40779403	103.975974	2022-03-12	4:48:12	IMG_0169.AVI	Unidentified Muridae	1	NA	Mammal	NA	NA	NA	NA	NA
20220329	CT02	1.40779403	103.975974	2022-03-14	4:51:54	IMG_0181.AVI	Unidentified Muridae	1	NA	Mammal	NA	NA	NA	NA	NA
20220329	CT02	1.40779403	103.975974	2022-03-15	20:05:16	IMG_0186.AVI	Unidentified Muridae	1	NA	Mammal	NA	NA	NA	NA	NA
20220329	CT02	1.40779403	103.975974	2022-03-15	20:33:32	IMG_0187.AVI	Unidentified Muridae	1	NA	Mammal	NA	NA	NA	NA	NA
20220329	CT02	1.40779403	103.975974	2022-03-15	21:02:10	IMG_0188.AVI	Unidentified Muridae	1	NA	Mammal	NA	NA	NA	NA	NA
20220329	CT02	1.40779403	103.975974	2022-03-15	1:07:24	IMG_0192.AVI	Unidentified Muridae	1	NA	Mammal	NA	NA	NA	NA	NA
20220329	CT02	1.40779403	103.975974	2022-03-15	1:14:18	IMG_0193.AVI	Unidentified Muridae	1	NA	Mammal	NA	NA	NA	NA	NA
20220329	CT02	1.40779403	103.975974	2022-03-15	2:16:46	IMG_0194.AVI	Unidentified Muridae	1	NA	Mammal	NA	NA	NA	NA	NA
20220329	CT02	1.40779403	103.975974	2022-03-15	5:14:40	IMG_0203.AVI	Unidentified Muridae	1	NA	Mammal	NA	NA	NA	NA	NA
20220329	CT02	1.40779403	103.975974	2022-03-16	19:44:18	IMG_0218.AVI	Unidentified Muridae	1	NA	Mammal	NA	NA	NA	NA	NA
20220329	CT02	1.40779403	103.975974	2022-03-16	20:35:50	IMG_0222.AVI	Unidentified Muridae	1	NA	Mammal	NA	NA	NA	NA	NA
20220329	CT02	1.40779403	103.975974	2022-03-16	5:27:04	IMG_0223.AVI	Unidentified Muridae	1	NA	Mammal	NA	NA	NA	NA	NA
20220329	CT02	1.40779403	103.975974	2022-03-17	3:34:52	IMG_0238.AVI	Unidentified Muridae	1	NA	Mammal	NA	NA	NA	NA	NA
20220329	CT02	1.40779403	103.975974	2022-03-18	19:41:46	IMG_0246.AVI	Unidentified Muridae	1	NA	Mammal	NA	NA	NA	NA	NA
20220329	CT02	1.40779403	103.975974	2022-03-18	4:04:12	IMG_0248.AVI	Unidentified Muridae	1	NA	Mammal	NA	NA	NA	NA	NA
20220329	CT02	1.40779403	103.975974	2022-03-19	23:26:14	IMG_0260.AVI	Unidentified Muridae	1	NA	Mammal	NA	NA	NA	NA	NA
20220329	CT02	1.40779403	103.975974	2022-03-20	20:39:16	IMG_0270.AVI	Unidentified Muridae	1	NA	Mammal	NA	NA	NA	NA	NA
20220329	CT02	1.40779403	103.975974	2022-03-20	21:03:30	IMG_0271.AVI	Unidentified Muridae	1	NA	Mammal	NA	NA	NA	NA	NA

Pulau Ubin Durian Appendix G - Camera Trap Data

20220329	CT02	1.40779403	103.975974	2022-03-20	21:03:54	IMG_0272.AVI	Unidentified Muridae	1	NA	Mammal	NA	NA	NA	NA	NA
20220329	CT02	1.40779403	103.975974	2022-03-21	20:55:56	IMG_0288.AVI	Unidentified Muridae	1	NA	Mammal	NA	NA	NA	NA	NA
20220329	CT02	1.40779403	103.975974	2022-03-22	4:00:24	IMG_0306.AVI	Unidentified Muridae	1	NA	Mammal	NA	NA	NA	NA	NA
20220329	CT02	1.40779403	103.975974	2022-03-23	21:06:30	IMG_0311.AVI	Unidentified Muridae	1	NA	Mammal	NA	NA	NA	NA	NA
20220329	CT02	1.40779403	103.975974	2022-03-23	2:11:00	IMG_0312.AVI	Unidentified Muridae	1	NA	Mammal	NA	NA	NA	NA	NA
20220329	CT02	1.40779403	103.975974	2022-03-23	3:24:26	IMG_0313.AVI	Unidentified Muridae	1	NA	Mammal	NA	NA	NA	NA	NA
20220329	CT02	1.40779403	103.975974	2022-03-23	6:27:14	IMG_0316.AVI	Unidentified Muridae	1	NA	Mammal	NA	NA	NA	NA	NA
20220329	CT02	1.40779403	103.975974	2022-03-24	20:02:50	IMG_0321.AVI	Unidentified Muridae	1	NA	Mammal	NA	NA	NA	NA	NA
20220329	CT02	1.40779403	103.975974	2022-03-24	20:41:14	IMG_0322.AVI	Unidentified Muridae	1	NA	Mammal	NA	NA	NA	NA	NA
20220329	CT02	1.40779403	103.975974	2022-03-24	23:15:30	IMG_0323.AVI	Unidentified Muridae	1	NA	Mammal	NA	NA	NA	NA	NA
20220329	CT02	1.40779403	103.975974	2022-03-24	3:29:58	IMG_0324.AVI	Unidentified Muridae	1	NA	Mammal	NA	NA	NA	NA	NA
20220329	CT02	1.40779403	103.975974	2022-03-25	22:01:06	IMG_0328.AVI	Unidentified Muridae	1	NA	Mammal	NA	NA	NA	NA	NA
20220329	CT02	1.40779403	103.975974	2022-03-26	21:30:56	IMG_0330.AVI	Unidentified Muridae	1	NA	Mammal	NA	NA	NA	NA	NA
20220329	CT02	1.40779403	103.975974	2022-03-26	22:16:58	IMG_0331.AVI	Unidentified Muridae	1	NA	Mammal	NA	NA	NA	NA	NA
20220329	CT02	1.40779403	103.975974	2022-03-27	19:57:18	IMG_0334.AVI	Unidentified Muridae	1	NA	Mammal	NA	NA	NA	NA	NA
20220329	CT02	1.40779403	103.975974	2022-03-28	19:39:54	IMG_0338.AVI	Unidentified Muridae	1	NA	Mammal	NA	NA	NA	NA	NA
20220329	CT02	1.40779403	103.975974	2022-03-28	1:21:20	IMG_0340.AVI	Unidentified Muridae	1	NA	Mammal	NA	NA	NA	NA	NA
20220329	CT02	1.40779403	103.975974	2022-03-28	3:44:34	IMG_0341.AVI	Unidentified Muridae	1	NA	Mammal	NA	NA	NA	NA	NA
20220329	CT02	1.40779403	103.975974	2022-03-11	2:17:46	IMG_0159.AVI	Unidentified Muridae	2	NA	Mammal	NA	NA	NA	NA	NA
20220329	CT02	1.40779403	103.975974	2022-03-11	2:18:16	IMG_0160.AVI	Unidentified Muridae	2	NA	Mammal	NA	NA	NA	NA	NA
20220329	CT02	1.40779403	103.975974	2022-03-15	21:02:54	IMG_0189.AVI	Unidentified Muridae	2	NA	Mammal	NA	NA	NA	NA	NA
20220329	CT02	1.40779403	103.975974	2022-03-17	22:42:22	IMG_0237.AVI	Unidentified Muridae	2	NA	Mammal	NA	NA	NA	NA	NA
20220329	CT02	1.40779403	103.975974	2022-03-28	21:19:42	IMG_0339.AVI	Unidentified Muridae	2	NA	Mammal	NA	NA	NA	NA	NA
20220329	CT02	1.40779403	103.975974	2022-02-28	17:18:32	IMG_0053.AVI	Varanus salvator	1	Malayan water monitor	Reptile	Least Concern; C	Least Concern	No	NA	NA
20220329	CT02	1.40779403	103.975974	2022-03-03	10:51:16	IMG_0091.AVI	Varanus salvator	1	Malayan water monitor	Reptile	Least Concern; C	Least Concern	No	NA	NA
20220329	CT02	1.40779403	103.975974	2022-03-07	8:06:02	IMG_0122.AVI	Varanus salvator	1	Malayan water monitor	Reptile	Least Concern; C	Least Concern	No	NA	NA
20220329	CT02	1.40779403	103.975974	2022-03-09	18:05:14	IMG_0143.AVI	Varanus salvator	1	Malayan water monitor	Reptile	Least Concern; C	Least Concern	No	NA	NA
20220329	CT02	1.40779403	103.975974	2022-03-16	7:50:14	IMG_0225.AVI	Varanus salvator	1	Malayan water monitor	Reptile	Least Concern; C	Least Concern	No	NA	NA
20220329	CT02	1.40779403	103.975974	2022-03-25	11:30:06	IMG_0327.AVI	Varanus salvator	1	Malayan water monitor	Reptile	Least Concern; C	Least Concern	No	NA	NA
20220329	CT02	1.40779403	103.975974	2022-02-26	11:01:18	IMG_0021.AVI	Varanus sp.	1	NA	Reptile	NA	NA	NA	NA	NA
20220419	CT02	1.40779403	103.975974	2022-04-18	19:18:10	IMG_0100.AVI	Caprimulgus macrurus	1	Large-tailed nightjar	Bird	Least Concern	Not Assessed	No	NA	NA
20220419	CT02	1.40779403	103.975974	2022-03-31	9:52:18	IMG_0018.AVI	Gallus gallus	2	Red junglefowl	Bird	Least Concern	Endangered	Yes	Endangered	NA
20220419	CT02	1.40779403	103.975974	2022-03-31	10:04:10	IMG_0019.AVI	Gallus gallus	2	Red junglefowl	Bird	Least Concern	Endangered	Yes	Endangered	NA
20220419	CT02	1.40779403	103.975974	2022-04-05	11:24:40	IMG_0040.AVI	Macaca fascicularis	1	Long-tailed macaque	Mammal	Vulnerable; CITE	Least Concern	Yes	Vulnerable	NA
20220419	CT02	1.40779403	103.975974	2022-04-05	11:25:02	IMG_0041.AVI	Macaca fascicularis	1	Long-tailed macaque	Mammal	Vulnerable; CITE	Least Concern	Yes	Vulnerable	NA
20220419	CT02	1.40779403	103.975974	2022-04-15	13:24:36	IMG_0073.AVI	Macaca fascicularis	1	Long-tailed macaque	Mammal	Vulnerable; CITE	Least Concern	Yes	Vulnerable	NA
20220419	CT02	1.40779403	103.975974	2022-04-15	13:34:58	IMG_0074.AVI	Macaca fascicularis	1	Long-tailed macaque	Mammal	Vulnerable; CITE	Least Concern	Yes	Vulnerable	NA
20220419	CT02	1.40779403	103.975974	2022-04-05	11:34:08	IMG_0044.AVI	Macaca fascicularis	2	Long-tailed macaque	Mammal	Vulnerable; CITE	Least Concern	Yes	Vulnerable	NA
20220419	CT02	1.40779403	103.975974	2022-04-15	13:37:00	IMG_0075.AVI	Macaca fascicularis	2	Long-tailed macaque	Mammal	Vulnerable; CITE	Least Concern	Yes	Vulnerable	NA
20220419	CT02	1.40779403	103.975974	2022-04-15	13:37:36	IMG_0076.AVI	Macaca fascicularis	2	Long-tailed macaque	Mammal	Vulnerable; CITE	Least Concern	Yes	Vulnerable	NA
20220419	CT02	1.40779403	103.975974	2022-04-05	11:32:56	IMG_0042.AVI	Macaca fascicularis	4	Long-tailed macaque	Mammal	Vulnerable; CITE	Least Concern	Yes	Vulnerable	NA
20220419	CT02	1.40779403	103.975974	2022-04-05	11:33:44	IMG_0043.AVI	Macaca fascicularis	5	Long-tailed macaque	Mammal	Vulnerable; CITE	Least Concern	Yes	Vulnerable	NA
20220419	CT02	1.40779403	103.975974	2022-03-31	22:02:28	IMG_0023.AVI	Paradoxurus musangus	1	Sumatran palm civet	Mammal	Least Concern	Least Concern	No	NA	NA
20220419	CT02	1.40779403	103.975974	2022-03-31	22:11:34	IMG_0024.AVI	Paradoxurus musangus	1	Sumatran palm civet	Mammal	Least Concern	Least Concern	No	NA	NA
20220419	CT02	1.40779403	103.975974	2022-03-31	22:24:56	IMG_0025.AVI	Paradoxurus musangus	1	Sumatran palm civet	Mammal	Least Concern	Least Concern	No	NA	NA
20220419	CT02	1.40779403	103.975974	2022-04-03	4:58:26	IMG_0034.AVI	Paradoxurus musangus	1	Sumatran palm civet	Mammal	Least Concern	Least Concern	No	NA	NA
20220419	CT02	1.40779403	103.975974	2022-04-03	5:16:50	IMG_0035.AVI	Paradoxurus musangus	1	Sumatran palm civet	Mammal	Least Concern	Least Concern	No	NA	NA
20220419	CT02	1.40779403	103.975974	2022-04-03	5:17:12	IMG_0036.AVI	Paradoxurus musangus	1	Sumatran palm civet	Mammal	Least Concern	Least Concern	No	NA	NA
20220419	CT02	1.40779403	103.975974	2022-04-08	19:53:46	IMG_0050.AVI	Paradoxurus musangus	1	Sumatran palm civet	Mammal	Least Concern	Least Concern	No	NA	NA
20220419	CT02	1.40779403	103.975974	2022-04-09	18:40:02	IMG_0052.AVI	Paradoxurus musangus	1	Sumatran palm civet	Mammal	Least Concern	Least Concern	No	NA	NA
20220419	CT02	1.40779403	103.975974	2022-04-10	4:39:48	IMG_0058.AVI	Paradoxurus musangus	1	Sumatran palm civet	Mammal	Least Concern	Least Concern	No	NA	NA
20220419	CT02	1.40779403	103.975974	2022-04-11	2:49:30	IMG_0060.AVI	Paradoxurus musangus	1	Sumatran palm civet	Mammal	Least Concern	Least Concern	No	NA	NA
20220419	CT02	1.40779403	103.975974	2022-04-11	5:20:04	IMG_0061.AVI	Paradoxurus musangus	1	Sumatran palm civet	Mammal	Least Concern	Least Concern	No	NA	NA
20220419	CT02	1.40779403	103.975974	2022-04-13	5:47:54	IMG_0069.AVI	Paradoxurus musangus	1	Sumatran palm civet	Mammal	Least Concern	Least Concern	No	NA	NA
20220419	CT02	1.40779403	103.975974	2022-04-13	6:06:14	IMG_0070.AVI	Paradoxurus musangus	1	Sumatran palm civet	Mammal	Least Concern	Least Concern	No	NA	NA
20220419	CT02	1.40779403	103.975974	2022-04-15	2:49:56	IMG_0078.AVI	Paradoxurus musangus	1	Sumatran palm civet	Mammal	Least Concern	Least Concern	No	NA	NA
20220419	CT02	1.40779403	103.975974	2022-04-17	20:14:42	IMG_0092.AVI	Paradoxurus musangus	1	Sumatran palm civet	Mammal	Least Concern	Least Concern	No	NA	NA
20220419	CT02	1.40779403	103.975974	2022-04-17	20:15:26	IMG_0093.AVI	Paradoxurus musangus	1	Sumatran palm civet	Mammal	Least Concern	Least Concern	No	NA	NA

Pulau Ubin Durian Appendix G - Camera Trap Data

20220419	CT02	1.40779403	103.975974	2022-04-17	20:14:22	IMG_0091.AVI	<i>Sus scrofa</i>	1	Eurasian wild boar	Mammal	Least Concern	Least Concern	No	NA	NA
20220419	CT02	1.40779403	103.975974	2022-04-18	18:19:54	IMG_0094.AVI	<i>Sus scrofa</i>	1	Eurasian wild boar	Mammal	Least Concern	Least Concern	No	NA	NA
20220419	CT02	1.40779403	103.975974	2022-04-18	18:52:44	IMG_0097.AVI	<i>Sus scrofa</i>	1	Eurasian wild boar	Mammal	Least Concern	Least Concern	No	NA	NA
20220419	CT02	1.40779403	103.975974	2022-04-18	18:53:04	IMG_0098.AVI	<i>Sus scrofa</i>	1	Eurasian wild boar	Mammal	Least Concern	Least Concern	No	NA	NA
20220419	CT02	1.40779403	103.975974	2022-04-18	5:20:34	IMG_0101.AVI	<i>Sus scrofa</i>	1	Eurasian wild boar	Mammal	Least Concern	Least Concern	No	NA	NA
20220419	CT02	1.40779403	103.975974	2022-04-07	9:00:10	IMG_0049.AVI	<i>Sus scrofa</i>	2	Eurasian wild boar	Mammal	Least Concern	Least Concern	No	NA	NA
20220419	CT02	1.40779403	103.975974	2022-04-18	18:51:56	IMG_0095.AVI	<i>Sus scrofa</i>	2	Eurasian wild boar	Mammal	Least Concern	Least Concern	No	NA	NA
20220419	CT02	1.40779403	103.975974	2022-04-18	18:52:22	IMG_0096.AVI	<i>Sus scrofa</i>	2	Eurasian wild boar	Mammal	Least Concern	Least Concern	No	NA	NA
20220419	CT02	1.40779403	103.975974	2022-04-03	0:54:06	IMG_0033.AVI	<i>Tragulus napu</i>	1	Greater mousedeer	Mammal	Least Concern	Critically Endangered	Yes	Critically Endangered	NA
20220419	CT02	1.40779403	103.975974	2022-04-13	12:15:48	IMG_0062.AVI	<i>Varanus salvator</i>	1	Malayan water monitor	Reptile	Least Concern	Least Concern	No	NA	NA
20220419	CT02	1.40779403	103.975974	2022-04-14	13:42:52	IMG_0071.AVI	<i>Varanus salvator</i>	1	Malayan water monitor	Reptile	Least Concern	Least Concern	No	NA	NA
20220223	CT03	1.408499032	103.977363	2022-02-17	11:59:46	IMG_0004.AVI	<i>Varanus salvator</i>	1	Malayan water monitor	Reptile	Least Concern	Least Concern	No	NA	NA
20220223	CT03	1.408499032	103.977363	2022-02-17	12:14:54	IMG_0005.AVI	<i>Varanus salvator</i>	1	Malayan water monitor	Reptile	Least Concern	Least Concern	No	NA	NA
20220223	CT03	1.408499032	103.977363	2022-02-17	12:15:16	IMG_0006.AVI	<i>Varanus salvator</i>	1	Malayan water monitor	Reptile	Least Concern	Least Concern	No	NA	NA
20220223	CT03	1.408499032	103.977363	2022-02-17	16:03:10	IMG_0007.AVI	<i>Acridotheres javanicus</i>	2	Javan myna	Bird	Least Concern	Not Assessed	No	NA	NA
20220223	CT03	1.408499032	103.977363	2022-02-17	16:03:36	IMG_0008.AVI	<i>Acridotheres javanicus</i>	1	Javan myna	Bird	Least Concern	Not Assessed	No	NA	NA
#####	CT03	1.408499032	103.977363	2022-02-17	21:47:36	IMG_0009.AVI	<i>Sus scrofa</i>	1	Eurasian wild boar	Mammal	Least Concern	Least Concern	No	NA	NA
#####	CT03	1.408499032	103.977363	2022-02-17	21:47:56	IMG_0010.AVI	<i>Sus scrofa</i>	1	Eurasian wild boar	Mammal	Least Concern	Least Concern	No	NA	NA
#####	CT03	1.408499032	103.977363	2022-02-17	21:48:18	IMG_0011.AVI	<i>Sus scrofa</i>	1	Eurasian wild boar	Mammal	Least Concern	Least Concern	No	NA	NA
#####	CT03	1.408499032	103.977363	2022-02-17	0:59:28	IMG_0013.AVI	Unidentified Muridae	1	NA	Mammal	NA	NA	NA	NA	NA
#####	CT03	1.408499032	103.977363	2022-02-17	1:38:52	IMG_0014.AVI	Unidentified Muridae	1	NA	Mammal	NA	NA	NA	NA	NA
#####	CT03	1.408499032	103.977363	2022-02-17	3:00:46	IMG_0015.AVI	Unidentified Muridae	1	NA	Mammal	NA	NA	NA	NA	NA
#####	CT03	1.408499032	103.977363	2022-02-18	4:41:26	IMG_0019.AVI	Unidentified Muridae	1	NA	Mammal	NA	NA	NA	NA	NA
#####	CT03	1.408499032	103.977363	2022-02-19	20:31:42	IMG_0020.AVI	Unidentified Muridae	1	NA	Mammal	NA	NA	NA	NA	NA
#####	CT03	1.408499032	103.977363	2022-02-19	5:03:54	IMG_0021.AVI	Unidentified Muridae	1	NA	Mammal	NA	NA	NA	NA	NA
#####	CT03	1.408499032	103.977363	2022-02-20	12:33:58	IMG_0022.AVI	<i>Varanus salvator</i>	1	Malayan water monitor	Reptile	Least Concern	Least Concern	No	NA	NA
#####	CT03	1.408499032	103.977363	2022-02-20	21:23:46	IMG_0076.AVI	<i>Paradoxurus musangus</i>	1	Sumatran palm civet	Mammal	Least Concern	Least Concern	No	NA	NA
#####	CT03	1.408499032	103.977363	2022-02-20	21:44:20	IMG_0077.AVI	Unidentified Muridae	1	NA	Mammal	NA	NA	NA	NA	NA
#####	CT03	1.408499032	103.977363	2022-02-20	22:22:40	IMG_0078.AVI	Unidentified Muridae	1	NA	Mammal	NA	NA	NA	NA	NA
#####	CT03	1.408499032	103.977363	2022-02-21	19:35:08	IMG_0079.AVI	<i>Sus scrofa</i>	1	Eurasian wild boar	Mammal	Least Concern	Least Concern	No	NA	NA
#####	CT03	1.408499032	103.977363	2022-02-21	23:38:00	IMG_0080.AVI	Unidentified Muridae	1	NA	Mammal	NA	NA	NA	NA	NA
#####	CT03	1.408499032	103.977363	2022-02-21	0:25:04	IMG_0081.AVI	Unidentified Muridae	1	NA	Mammal	NA	NA	NA	NA	NA
#####	CT03	1.408499032	103.977363	2022-02-21	2:27:44	IMG_0082.AVI	Unidentified Muridae	1	NA	Mammal	NA	NA	NA	NA	NA
#####	CT03	1.408499032	103.977363	2022-02-21	4:43:30	IMG_0083.AVI	Unidentified Muridae	1	NA	Mammal	NA	NA	NA	NA	NA
#####	CT03	1.408499032	103.977363	2022-02-22	20:27:34	IMG_0085.AVI	Unidentified Muridae	1	NA	Mammal	NA	NA	NA	NA	NA
#####	CT03	1.408499032	103.977363	2022-02-22	3:49:36	IMG_0086.AVI	Unidentified Muridae	1	NA	Mammal	NA	NA	NA	NA	NA
#####	CT03	1.408499032	103.977363	2022-02-26	8:29:28	IMG_0093.AVI	<i>Acridotheres javanicus</i>	1	Javan myna	Bird	Least Concern	Not Assessed	No	NA	NA
#####	CT03	1.408499032	103.977363	2022-02-28	18:21:02	IMG_0140.AVI	<i>Acridotheres javanicus</i>	1	Javan myna	Bird	Least Concern	Not Assessed	No	NA	NA
#####	CT03	1.408499032	103.977363	2022-03-23	11:23:10	IMG_0646.AVI	<i>Acridotheres javanicus</i>	1	Javan myna	Bird	Least Concern	Not Assessed	No	NA	NA
#####	CT03	1.408499032	103.977363	2022-02-24	17:13:44	IMG_0065.AVI	<i>Acridotheres javanicus</i>	2	Javan myna	Bird	Least Concern	Not Assessed	No	NA	NA
#####	CT03	1.408499032	103.977363	2022-02-28	10:41:42	IMG_0119.AVI	<i>Acridotheres javanicus</i>	2	Javan myna	Bird	Least Concern	Not Assessed	No	NA	NA
#####	CT03	1.408499032	103.977363	2022-03-04	18:01:16	IMG_0299.AVI	<i>Acridotheres javanicus</i>	2	Javan myna	Bird	Least Concern	Not Assessed	No	NA	NA
#####	CT03	1.408499032	103.977363	2022-03-06	14:16:22	IMG_0329.AVI	<i>Acridotheres javanicus</i>	2	Javan myna	Bird	Least Concern	Not Assessed	No	NA	NA
#####	CT03	1.408499032	103.977363	2022-03-07	11:42:04	IMG_0356.AVI	<i>Acridotheres javanicus</i>	2	Javan myna	Bird	Least Concern	Not Assessed	No	NA	NA
#####	CT03	1.408499032	103.977363	2022-03-11	11:02:24	IMG_0430.AVI	<i>Acridotheres javanicus</i>	2	Javan myna	Bird	Least Concern	Not Assessed	No	NA	NA
#####	CT03	1.408499032	103.977363	2022-03-21	17:03:14	IMG_0612.AVI	<i>Acridotheres javanicus</i>	2	Javan myna	Bird	Least Concern	Not Assessed	No	NA	NA
#####	CT03	1.408499032	103.977363	2022-02-25	0:22:42	IMG_0090.AVI	<i>Felis catus</i>	1	Feral cat	Mammal	Not Assessed	Not Assessed	No	NA	NA
#####	CT03	1.408499032	103.977363	2022-02-25	0:24:00	IMG_0091.AVI	<i>Felis catus</i>	1	Feral cat	Mammal	Not Assessed	Not Assessed	No	NA	NA
#####	CT03	1.408499032	103.977363	2022-02-25	2:11:24	IMG_0092.AVI	<i>Felis catus</i>	1	Feral cat	Mammal	Not Assessed	Not Assessed	No	NA	NA
#####	CT03	1.408499032	103.977363	2022-02-26	21:28:28	IMG_0103.AVI	<i>Felis catus</i>	1	Feral cat	Mammal	Not Assessed	Not Assessed	No	NA	NA
#####	CT03	1.408499032	103.977363	2022-02-26	21:28:54	IMG_0104.AVI	<i>Felis catus</i>	1	Feral cat	Mammal	Not Assessed	Not Assessed	No	NA	NA
#####	CT03	1.408499032	103.977363	2022-02-26	23:21:58	IMG_0105.AVI	<i>Felis catus</i>	1	Feral cat	Mammal	Not Assessed	Not Assessed	No	NA	NA
#####	CT03	1.408499032	103.977363	2022-02-27	19:39:04	IMG_0115.AVI	<i>Felis catus</i>	1	Feral cat	Mammal	Not Assessed	Not Assessed	No	NA	NA
#####	CT03	1.408499032	103.977363	2022-02-27	19:39:26	IMG_0116.AVI	<i>Felis catus</i>	1	Feral cat	Mammal	Not Assessed	Not Assessed	No	NA	NA
#####	CT03	1.408499032	103.977363	2022-02-27	21:35:00	IMG_0118.AVI	<i>Felis catus</i>	1	Feral cat	Mammal	Not Assessed	Not Assessed	No	NA	NA
#####	CT03	1.408499032	103.977363	2022-03-01	5:11:02	IMG_0188.AVI	<i>Felis catus</i>	1	Feral cat	Mammal	Not Assessed	Not Assessed	No	NA	NA
#####	CT03	1.408499032	103.977363	2022-03-02	8:51:28	IMG_0192.AVI	<i>Felis catus</i>	1	Feral cat	Mammal	Not Assessed	Not Assessed	No	NA	NA
#####	CT03	1.408499032	103.977363	2022-03-02	5:53:08	IMG_0240.AVI	<i>Felis catus</i>	1	Feral cat	Mammal	Not Assessed	Not Assessed	No	NA	NA

Pulau Ubin Durian Appendix G - Camera Trap Data

20220329	CT03	1.408499032	103.977363	2022-03-26	15:44:40	IMG_0688.AVI	<i>Varanus salvator</i>	1	Malayan water monitor	Reptile	Least Concern; C	Least Concern	No	NA	NA
20220329	CT03	1.408499032	103.977363	2022-03-26	17:46:58	IMG_0689.AVI	<i>Varanus salvator</i>	1	Malayan water monitor	Reptile	Least Concern; C	Least Concern	No	NA	NA
20220329	CT03	1.408499032	103.977363	2022-03-16	16:29:30	IMG_0490.AVI	<i>Varanus sp.</i>	1	NA	Reptile	NA	NA	NA	NA	NA
20220329	CT03	1.408499032	103.977363	2022-03-23	16:08:14	IMG_0648.AVI	<i>Varanus sp.</i>	1	NA	Reptile	NA	NA	NA	NA	NA
20220329	CT03	1.408499032	103.977363	2022-03-24	12:48:08	IMG_0660.AVI	<i>Varanus sp.</i>	1	NA	Reptile	NA	NA	NA	NA	NA
20220329	CT03	1.408499032	103.977363	2022-03-25	13:15:46	IMG_0684.AVI	<i>Varanus sp.</i>	1	NA	Reptile	NA	NA	NA	NA	NA
20220419	CT03	1.408499032	103.977363	2022-03-31	16:33:14	IMG_0038.AVI	<i>Acridotheres javanicus</i>	1	Javan myna	Bird	Least Concern	Not Assessed	No	NA	2sp
20220419	CT03	1.408499032	103.977363	2022-03-31	16:34:54	IMG_0040.AVI	<i>Acridotheres javanicus</i>	1	Javan myna	Bird	Least Concern	Not Assessed	No	NA	2sp
20220419	CT03	1.408499032	103.977363	2022-04-09	12:55:14	IMG_0173.AVI	<i>Acridotheres javanicus</i>	1	Javan myna	Bird	Least Concern	Not Assessed	No	NA	2sp
20220419	CT03	1.408499032	103.977363	2022-04-09	13:29:20	IMG_0175.AVI	<i>Acridotheres javanicus</i>	1	Javan myna	Bird	Least Concern	Not Assessed	No	NA	2sp
20220419	CT03	1.408499032	103.977363	2022-04-13	15:46:44	IMG_0221.AVI	<i>Acridotheres javanicus</i>	1	Javan myna	Bird	Least Concern	Not Assessed	No	NA	2sp
20220419	CT03	1.408499032	103.977363	2022-03-31	16:32:52	IMG_0037 2sp.AVI	<i>Acridotheres javanicus</i>	2	Javan myna	Bird	Least Concern	Not Assessed	No	NA	NA
20220419	CT03	1.408499032	103.977363	2022-04-09	12:54:02	IMG_0171 3sp.AVI	<i>Acridotheres javanicus</i>	2	Javan myna	Bird	Least Concern	Not Assessed	No	NA	NA
20220419	CT03	1.408499032	103.977363	2022-04-09	12:54:22	IMG_0172 2sp.AVI	<i>Acridotheres javanicus</i>	2	Javan myna	Bird	Least Concern	Not Assessed	No	NA	NA
20220419	CT03	1.408499032	103.977363	2022-04-12	10:54:20	IMG_0213.AVI	<i>Acridotheres javanicus</i>	2	Javan myna	Bird	Least Concern	Not Assessed	No	NA	NA
20220419	CT03	1.408499032	103.977363	2022-03-31	20:16:04	IMG_0047.AVI	<i>Felis catus</i>	1	Feral cat	Mammal	Not Assessed	Not Assessed	No	NA	NA
20220419	CT03	1.408499032	103.977363	2022-03-31	2:00:52	IMG_0051.AVI	<i>Felis catus</i>	1	Feral cat	Mammal	Not Assessed	Not Assessed	No	NA	NA
20220419	CT03	1.408499032	103.977363	2022-03-31	2:01:34	IMG_0052.AVI	<i>Felis catus</i>	1	Feral cat	Mammal	Not Assessed	Not Assessed	No	NA	NA
20220419	CT03	1.408499032	103.977363	2022-04-01	20:37:26	IMG_0062.AVI	<i>Felis catus</i>	1	Feral cat	Mammal	Not Assessed	Not Assessed	No	NA	NA
20220419	CT03	1.408499032	103.977363	2022-04-01	21:55:36	IMG_0065.AVI	<i>Felis catus</i>	1	Feral cat	Mammal	Not Assessed	Not Assessed	No	NA	NA
20220419	CT03	1.408499032	103.977363	2022-04-02	19:20:10	IMG_0075.AVI	<i>Felis catus</i>	1	Feral cat	Mammal	Not Assessed	Not Assessed	No	NA	NA
20220419	CT03	1.408499032	103.977363	2022-04-02	21:27:36	IMG_0079.AVI	<i>Felis catus</i>	1	Feral cat	Mammal	Not Assessed	Not Assessed	No	NA	NA
20220419	CT03	1.408499032	103.977363	2022-04-05	23:11:52	IMG_0124.AVI	<i>Felis catus</i>	1	Feral cat	Mammal	Not Assessed	Not Assessed	No	NA	NA
20220419	CT03	1.408499032	103.977363	2022-04-05	1:28:00	IMG_0125.AVI	<i>Felis catus</i>	1	Feral cat	Mammal	Not Assessed	Not Assessed	No	NA	NA
20220419	CT03	1.408499032	103.977363	2022-04-08	0:01:48	IMG_0167.AVI	<i>Felis catus</i>	1	Feral cat	Mammal	Not Assessed	Not Assessed	No	NA	NA
20220419	CT03	1.408499032	103.977363	2022-04-08	2:24:50	IMG_0168.AVI	<i>Felis catus</i>	1	Feral cat	Mammal	Not Assessed	Not Assessed	No	NA	NA
20220419	CT03	1.408499032	103.977363	2022-04-09	5:01:32	IMG_0183.AVI	<i>Felis catus</i>	1	Feral cat	Mammal	Not Assessed	Not Assessed	No	NA	NA
20220419	CT03	1.408499032	103.977363	2022-04-09	7:10:12	IMG_0187.AVI	<i>Felis catus</i>	1	Feral cat	Mammal	Not Assessed	Not Assessed	No	NA	NA
20220419	CT03	1.408499032	103.977363	2022-04-10	22:14:04	IMG_0194.AVI	<i>Felis catus</i>	1	Feral cat	Mammal	Not Assessed	Not Assessed	No	NA	NA
20220419	CT03	1.408499032	103.977363	2022-04-10	22:14:24	IMG_0195.AVI	<i>Felis catus</i>	1	Feral cat	Mammal	Not Assessed	Not Assessed	No	NA	NA
20220419	CT03	1.408499032	103.977363	2022-04-10	0:37:50	IMG_0196.AVI	<i>Felis catus</i>	1	Feral cat	Mammal	Not Assessed	Not Assessed	No	NA	NA
20220419	CT03	1.408499032	103.977363	2022-04-10	0:57:10	IMG_0197.AVI	<i>Felis catus</i>	1	Feral cat	Mammal	Not Assessed	Not Assessed	No	NA	NA
20220419	CT03	1.408499032	103.977363	2022-04-11	19:03:06	IMG_0210.AVI	<i>Felis catus</i>	1	Feral cat	Mammal	Not Assessed	Not Assessed	No	NA	NA
20220419	CT03	1.408499032	103.977363	2022-04-11	20:53:46	IMG_0211.AVI	<i>Felis catus</i>	1	Feral cat	Mammal	Not Assessed	Not Assessed	No	NA	NA
20220419	CT03	1.408499032	103.977363	2022-04-11	20:54:10	IMG_0212.AVI	<i>Felis catus</i>	1	Feral cat	Mammal	Not Assessed	Not Assessed	No	NA	NA
20220419	CT03	1.408499032	103.977363	2022-04-12	5:02:44	IMG_0219.AVI	<i>Felis catus</i>	1	Feral cat	Mammal	Not Assessed	Not Assessed	No	NA	NA
20220419	CT03	1.408499032	103.977363	2022-04-12	5:45:04	IMG_0220 caughtrat.AVI	<i>Felis catus</i>	1	Feral cat	Mammal	Not Assessed	Not Assessed	No	NA	NA
20220419	CT03	1.408499032	103.977363	2022-04-13	22:20:26	IMG_0238.AVI	<i>Felis catus</i>	1	Feral cat	Mammal	Not Assessed	Not Assessed	No	NA	NA
20220419	CT03	1.408499032	103.977363	2022-04-14	22:04:04	IMG_0250.AVI	<i>Felis catus</i>	1	Feral cat	Mammal	Not Assessed	Not Assessed	No	NA	NA
20220419	CT03	1.408499032	103.977363	2022-04-16	21:32:54	IMG_0258.AVI	<i>Felis catus</i>	1	Feral cat	Mammal	Not Assessed	Not Assessed	No	NA	NA
20220419	CT03	1.408499032	103.977363	2022-04-16	21:34:48	IMG_0259.AVI	<i>Felis catus</i>	1	Feral cat	Mammal	Not Assessed	Not Assessed	No	NA	NA
20220419	CT03	1.408499032	103.977363	2022-04-16	22:07:16	IMG_0260.AVI	<i>Felis catus</i>	1	Feral cat	Mammal	Not Assessed	Not Assessed	No	NA	NA
20220419	CT03	1.408499032	103.977363	2022-04-16	22:18:46	IMG_0261.AVI	<i>Felis catus</i>	1	Feral cat	Mammal	Not Assessed	Not Assessed	No	NA	NA
20220419	CT03	1.408499032	103.977363	2022-04-16	23:58:26	IMG_0263.AVI	<i>Felis catus</i>	1	Feral cat	Mammal	Not Assessed	Not Assessed	No	NA	NA
20220419	CT03	1.408499032	103.977363	2022-04-16	23:59:06	IMG_0264.AVI	<i>Felis catus</i>	1	Feral cat	Mammal	Not Assessed	Not Assessed	No	NA	NA
20220419	CT03	1.408499032	103.977363	2022-04-16	23:59:32	IMG_0265.AVI	<i>Felis catus</i>	1	Feral cat	Mammal	Not Assessed	Not Assessed	No	NA	NA
20220419	CT03	1.408499032	103.977363	2022-04-16	0:09:38	IMG_0266.AVI	<i>Felis catus</i>	1	Feral cat	Mammal	Not Assessed	Not Assessed	No	NA	NA
20220419	CT03	1.408499032	103.977363	2022-04-18	9:43:12	IMG_0287.AVI	<i>Gallus gallus</i>	1	Red junglefowl	Bird	Least Concern	Endangered	Yes	Endangered	NA
20220419	CT03	1.408499032	103.977363	2022-04-13	19:27:04	IMG_0232.AVI	<i>Lutrogale perspicillata</i>	11	Smooth otter	Mammal	Vulnerable; CITE	Endangered	Yes	Endangered	NA
20220419	CT03	1.408499032	103.977363	2022-04-13	7:51:46	IMG_0244.AVI	<i>Lutrogale perspicillata</i>	4	Smooth otter	Mammal	Vulnerable; CITE	Endangered	Yes	Endangered	NA
20220419	CT03	1.408499032	103.977363	2022-04-15	11:50:48	IMG_0251.AVI	<i>Lutrogale perspicillata</i>	9	Smooth otter	Mammal	Vulnerable; CITE	Endangered	Yes	Endangered	NA
20220419	CT03	1.408499032	103.977363	2022-03-31	2:52:32	IMG_0053.AVI	<i>Paradoxurus musangus</i>	1	Sumatran palm civet	Mammal	Least Concern	Least Concern	No	NA	NA
20220419	CT03	1.408499032	103.977363	2022-03-31	3:04:44	IMG_0054.AVI	<i>Paradoxurus musangus</i>	1	Sumatran palm civet	Mammal	Least Concern	Least Concern	No	NA	NA
20220419	CT03	1.408499032	103.977363	2022-04-01	4:32:24	IMG_0066.AVI	<i>Paradoxurus musangus</i>	1	Sumatran palm civet	Mammal	Least Concern	Least Concern	No	NA	NA
20220419	CT03	1.408499032	103.977363	2022-04-02	6:12:46	IMG_0080.AVI	<i>Paradoxurus musangus</i>	1	Sumatran palm civet	Mammal	Least Concern	Least Concern	No	NA	NA
20220419	CT03	1.408499032	103.977363	2022-04-05	4:22:32	IMG_0126.AVI	<i>Paradoxurus musangus</i>	1	Sumatran palm civet	Mammal	Least Concern	Least Concern	No	NA	NA
20220419	CT03	1.408499032	103.977363	2022-04-05	4:23:18	IMG_0127.AVI	<i>Paradoxurus musangus</i>	1	Sumatran palm civet	Mammal	Least Concern	Least Concern	No	NA	NA
20220419	CT03	1.408499032	103.977363	2022-04-13	23:37:28	IMG_0239.AVI	<i>Paradoxurus musangus</i>	1	Sumatran palm civet	Mammal	Least Concern	Least Concern	No	NA	NA

Pulau Ubin Durian Appendix G - Camera Trap Data

20220419	CT03	1.408499032	103.977363	2022-03-31	13:03:46	IMG_0031.AVI	<i>Varanus salvator</i>	1	Malayan water monitor	Reptile	Least Concern; C	Least Concern	No	NA	NA
20220419	CT03	1.408499032	103.977363	2022-04-04	12:53:08	IMG_0097.AVI	<i>Varanus salvator</i>	1	Malayan water monitor	Reptile	Least Concern; C	Least Concern	No	NA	NA
20220419	CT03	1.408499032	103.977363	2022-04-04	14:14:28	IMG_0098.AVI	<i>Varanus salvator</i>	1	Malayan water monitor	Reptile	Least Concern; C	Least Concern	No	NA	NA
20220419	CT03	1.408499032	103.977363	2022-04-05	13:22:02	IMG_0109.AVI	<i>Varanus salvator</i>	1	Malayan water monitor	Reptile	Least Concern; C	Least Concern	No	NA	NA
20220419	CT03	1.408499032	103.977363	2022-04-05	14:07:44	IMG_0111.AVI	<i>Varanus salvator</i>	1	Malayan water monitor	Reptile	Least Concern; C	Least Concern	No	NA	NA
20220419	CT03	1.408499032	103.977363	2022-04-06	9:04:10	IMG_0129.AVI	<i>Varanus salvator</i>	1	Malayan water monitor	Reptile	Least Concern; C	Least Concern	No	NA	NA
20220419	CT03	1.408499032	103.977363	2022-04-17	12:07:42	IMG_0270.AVI	<i>Varanus salvator</i>	1	Malayan water monitor	Reptile	Least Concern; C	Least Concern	No	NA	NA
20220419	CT03	1.408499032	103.977363	2022-04-17	12:45:24	IMG_0271.AVI	<i>Varanus salvator</i>	1	Malayan water monitor	Reptile	Least Concern; C	Least Concern	No	NA	NA
20220419	CT03	1.408499032	103.977363	2022-04-17	12:53:32	IMG_0272.AVI	<i>Varanus salvator</i>	1	Malayan water monitor	Reptile	Least Concern; C	Least Concern	No	NA	NA
20220419	CT03	1.408499032	103.977363	2022-04-18	14:24:24	IMG_0288.AVI	<i>Varanus salvator</i>	1	Malayan water monitor	Reptile	Least Concern; C	Least Concern	No	NA	NA
20220419	CT03	1.408499032	103.977363	2022-04-14	8:29:06	IMG_0245.AVI	<i>Varanus salvator</i>	2	Malayan water monitor	Reptile	Least Concern; C	Least Concern	No	NA	NA
20220223	CT04	1.409626985	103.977587	2022-02-17	11:19:00	IMG_0008.AVI	<i>Gallus gallus</i>	1	Red junglefowl	Bird	Least Concern	Endangered	Yes	Endangered	NA
20220223	CT04	1.409626985	103.977587	2022-02-17	13:10:32	IMG_0009.AVI	<i>Sus scrofa</i>	1	Eurasian wild boar	Mammal	Least Concern	Least Concern	No	NA	NA
20220223	CT04	1.409626985	103.977587	2022-02-17	17:45:38	IMG_0010.AVI	<i>Callosciurus notatus</i>	1	Plantain squirrel	Mammal	Least Concern	Not Assessed	No	NA	NA
20220223	CT04	1.409626985	103.977587	2022-02-17	17:51:22	IMG_0011.AVI	<i>Sus scrofa</i>	1	Eurasian wild boar	Mammal	Least Concern	Least Concern	No	NA	NA
20220223	CT04	1.409626985	103.977587	2022-02-17	17:51:44	IMG_0012.AVI	<i>Sus scrofa</i>	1	Eurasian wild boar	Mammal	Least Concern	Least Concern	No	NA	NA
20220223	CT04	1.409626985	103.977587	2022-02-17	18:49:28	IMG_0013.AVI	<i>Tragulus napu</i>	1	Greater mousedeer	Mammal	Least Concern	Critically Endangered	Yes	Critically Endangered	NA
20220223	CT04	1.409626985	103.977587	2022-02-17	18:49:52	IMG_0014.AVI	<i>Tragulus napu</i>	1	Greater mousedeer	Mammal	Least Concern	Critically Endangered	Yes	Critically Endangered	NA
20220223	CT04	1.409626985	103.977587	2022-02-17	5:20:00	IMG_0015.AVI	<i>Sus scrofa</i>	1	Eurasian wild boar	Mammal	Least Concern	Least Concern	No	NA	NA
20220223	CT04	1.409626985	103.977587	2022-02-18	9:32:50	IMG_0016.AVI	<i>Felis catus</i>	1	Feral cat	Mammal	Not Assessed	Not Assessed	No	NA	NA
20220223	CT04	1.409626985	103.977587	2022-02-18	19:42:30	IMG_0017.AVI	<i>Felis catus</i>	1	Feral cat	Mammal	Not Assessed	Not Assessed	No	NA	NA
20220223	CT04	1.409626985	103.977587	2022-02-18	22:57:44	IMG_0019.AVI	<i>Tragulus napu</i>	1	Greater mousedeer	Mammal	Least Concern	Critically Endangered	Yes	Critically Endangered	NA
20220223	CT04	1.409626985	103.977587	2022-02-18	22:58:54	IMG_0020.AVI	<i>Tragulus napu</i>	1	Greater mousedeer	Mammal	Least Concern	Critically Endangered	Yes	Critically Endangered	NA
20220223	CT04	1.409626985	103.977587	2022-02-18	22:59:18	IMG_0021.AVI	<i>Tragulus napu</i>	1	Greater mousedeer	Mammal	Least Concern	Critically Endangered	Yes	Critically Endangered	NA
20220223	CT04	1.409626985	103.977587	2022-02-18	5:04:50	IMG_0022.AVI	<i>Tragulus napu</i>	1	Greater mousedeer	Mammal	Least Concern	Critically Endangered	Yes	Critically Endangered	NA
20220223	CT04	1.409626985	103.977587	2022-02-19	10:59:58	IMG_0023.AVI	<i>Tragulus napu</i>	1	Greater mousedeer	Mammal	Least Concern	Critically Endangered	Yes	Critically Endangered	NA
20220223	CT04	1.409626985	103.977587	2022-02-19	12:55:24	IMG_0024.AVI	<i>Tragulus napu</i>	1	Greater mousedeer	Mammal	Least Concern	Critically Endangered	Yes	Critically Endangered	NA
20220223	CT04	1.409626985	103.977587	2022-02-19	13:44:18	IMG_0025.AVI	<i>Macaca fascicularis</i>	1	Long-tailed macaque	Mammal	Vulnerable; CITE	Least Concern	Yes	Vulnerable	NA
20220223	CT04	1.409626985	103.977587	2022-02-19	13:46:48	IMG_0026.AVI	<i>Macaca fascicularis</i>	1	Long-tailed macaque	Mammal	Vulnerable; CITE	Least Concern	Yes	Vulnerable	NA
20220223	CT04	1.409626985	103.977587	2022-02-19	13:47:36	IMG_0027.AVI	<i>Macaca fascicularis</i>	1	Long-tailed macaque	Mammal	Vulnerable; CITE	Least Concern	Yes	Vulnerable	NA
20220223	CT04	1.409626985	103.977587	2022-02-19	13:47:58	IMG_0028.AVI	<i>Macaca fascicularis</i>	1	Long-tailed macaque	Mammal	Vulnerable; CITE	Least Concern	Yes	Vulnerable	NA
20220223	CT04	1.409626985	103.977587	2022-02-19	13:48:22	IMG_0029.AVI	<i>Macaca fascicularis</i>	1	Long-tailed macaque	Mammal	Vulnerable; CITE	Least Concern	Yes	Vulnerable	NA
20220223	CT04	1.409626985	103.977587	2022-02-19	13:49:32	IMG_0030.AVI	<i>Macaca fascicularis</i>	1	Long-tailed macaque	Mammal	Vulnerable; CITE	Least Concern	Yes	Vulnerable	NA
20220223	CT04	1.409626985	103.977587	2022-02-19	13:50:38	IMG_0031.AVI	<i>Macaca fascicularis</i>	1	Long-tailed macaque	Mammal	Vulnerable; CITE	Least Concern	Yes	Vulnerable	NA
20220223	CT04	1.409626985	103.977587	2022-02-19	13:51:52	IMG_0032.AVI	<i>Macaca fascicularis</i>	2	Long-tailed macaque	Mammal	Vulnerable; CITE	Least Concern	Yes	Vulnerable	NA
20220223	CT04	1.409626985	103.977587	2022-02-19	14:31:42	IMG_0033.AVI	<i>Sus scrofa</i>	1	Eurasian wild boar	Mammal	Least Concern	Least Concern	No	NA	NA
20220223	CT04	1.409626985	103.977587	2022-02-19	15:26:12	IMG_0034.AVI	<i>Gallus gallus</i>	1	Red junglefowl	Bird	Least Concern	Endangered	Yes	Endangered	NA
20220223	CT04	1.409626985	103.977587	2022-02-19	15:30:38	IMG_0035.AVI	<i>Gallus gallus</i>	2	Red junglefowl	Bird	Least Concern	Endangered	Yes	Endangered	NA
20220223	CT04	1.409626985	103.977587	2022-02-20	9:41:12	IMG_0036.AVI	<i>Felis catus</i>	1	Feral cat	Mammal	Not Assessed	Not Assessed	No	NA	NA
20220223	CT04	1.409626985	103.977587	2022-02-20	12:41:32	IMG_0037.AVI	<i>Sus scrofa</i>	1	Eurasian wild boar	Mammal	Least Concern	Least Concern	No	NA	NA
20220223	CT04	1.409626985	103.977587	2022-02-20	12:41:52	IMG_0038.AVI	<i>Sus scrofa</i>	1	Eurasian wild boar	Mammal	Least Concern	Least Concern	No	NA	NA
20220223	CT04	1.409626985	103.977587	2022-02-20	15:44:14	IMG_0039.AVI	<i>Sus scrofa</i>	1	Eurasian wild boar	Mammal	Least Concern	Least Concern	No	NA	NA
20220223	CT04	1.409626985	103.977587	2022-02-20	16:53:56	IMG_0040.AVI	<i>Sus scrofa</i>	1	Eurasian wild boar	Mammal	Least Concern	Least Concern	No	NA	NA
20220223	CT04	1.409626985	103.977587	2022-02-20	18:32:30	IMG_0041.AVI	<i>Sus scrofa</i>	1	Eurasian wild boar	Mammal	Least Concern	Least Concern	No	NA	NA
20220223	CT04	1.409626985	103.977587	2022-02-20	18:48:52	IMG_0042.AVI	<i>Gallus gallus</i>	1	Red junglefowl	Bird	Least Concern	Endangered	Yes	Endangered	NA
20220223	CT04	1.409626985	103.977587	2022-02-20	18:52:04	IMG_0043.AVI	<i>Gallus gallus</i>	1	Red junglefowl	Bird	Least Concern	Endangered	Yes	Endangered	NA
20220223	CT04	1.409626985	103.977587	2022-02-20	20:09:44	IMG_0044.AVI	<i>Sus scrofa</i>	1	Eurasian wild boar	Mammal	Least Concern	Least Concern	No	NA	NA
20220223	CT04	1.409626985	103.977587	2022-02-20	23:44:52	IMG_0045.AVI	<i>Tragulus napu</i>	1	Greater mousedeer	Mammal	Least Concern	Critically Endangered	Yes	Critically Endangered	NA
20220223	CT04	1.409626985	103.977587	2022-02-20	5:41:34	IMG_0046.AVI	<i>Tragulus napu</i>	1	Greater mousedeer	Mammal	Least Concern	Critically Endangered	Yes	Critically Endangered	NA
20220223	CT04	1.409626985	103.977587	2022-02-21	19:25:36	IMG_0048.AVI	<i>Tragulus napu</i>	1	Greater mousedeer	Mammal	Least Concern	Critically Endangered	Yes	Critically Endangered	NA
20220223	CT04	1.409626985	103.977587	2022-02-21	23:07:48	IMG_0049.AVI	<i>Sus scrofa</i>	1	Eurasian wild boar	Mammal	Least Concern	Least Concern	No	NA	NA
20220223	CT04	1.409626985	103.977587	2022-02-21	23:30:06	IMG_0050.AVI	<i>Tragulus napu</i>	1	Greater mousedeer	Mammal	Least Concern	Critically Endangered	Yes	Critically Endangered	NA
20220223	CT04	1.409626985	103.977587	2022-02-22	16:25:18	IMG_0051.AVI	<i>Macaca fascicularis</i>	1	Long-tailed macaque	Mammal	Vulnerable; CITE	Least Concern	Yes	Vulnerable	NA
20220223	CT04	1.409626985	103.977587	2022-02-22	16:26:02	IMG_0052.AVI	<i>Macaca fascicularis</i>	1	Long-tailed macaque	Mammal	Vulnerable; CITE	Least Concern	Yes	Vulnerable	NA
20220223	CT04	1.409626985	103.977587	2022-02-22	16:26:26	IMG_0053.AVI	<i>Macaca fascicularis</i>	2	Long-tailed macaque	Mammal	Vulnerable; CITE	Least Concern	Yes	Vulnerable	NA
20220223	CT04	1.409626985	103.977587	2022-02-22	16:27:00	IMG_0054.AVI	<i>Macaca fascicularis</i>	1	Long-tailed macaque	Mammal	Vulnerable; CITE	Least Concern	Yes	Vulnerable	NA
20220223	CT04	1.409626985	103.977587	2022-02-22	16:29:04	IMG_0055.AVI	<i>Macaca fascicularis</i>	1	Long-tailed macaque	Mammal	Vulnerable; CITE	Least Concern	Yes	Vulnerable	NA
20220223	CT04	1.409626985	103.977587	2022-02-22	16:30:20	IMG_0056.AVI	<i>Macaca fascicularis</i>	1	Long-tailed macaque	Mammal	Vulnerable; CITE	Least Concern	Yes	Vulnerable	NA

Pulau Ubin Durian Appendix G - Camera Trap Data

20220419	CT04	1.409626985	103.977587	2022-04-16	4:11:24	IMG_0162.AVI	<i>Tragulus napu</i>	2	Greater mousedeer	Mammal	Least Concern	Critically Endangered	Yes	Critically Endangered	NA
20220419	CT04	1.409626985	103.977587	2022-04-16	4:11:52	IMG_0163.AVI	<i>Tragulus napu</i>	2	Greater mousedeer	Mammal	Least Concern	Critically Endangered	Yes	Critically Endangered	NA
20220419	CT04	1.409626985	103.977587	2022-04-16	4:12:28	IMG_0164.AVI	<i>Tragulus napu</i>	2	Greater mousedeer	Mammal	Least Concern	Critically Endangered	Yes	Critically Endangered	NA
20220419	CT04	1.409626985	103.977587	2022-04-16	4:13:28	IMG_0165.AVI	<i>Tragulus napu</i>	2	Greater mousedeer	Mammal	Least Concern	Critically Endangered	Yes	Critically Endangered	NA
20220419	CT04	1.409626985	103.977587	2022-04-16	4:13:52	IMG_0166.AVI	<i>Tragulus napu</i>	2	Greater mousedeer	Mammal	Least Concern	Critically Endangered	Yes	Critically Endangered	NA
20220419	CT04	1.409626985	103.977587	2022-04-16	4:14:42	IMG_0167.AVI	<i>Tragulus napu</i>	2	Greater mousedeer	Mammal	Least Concern	Critically Endangered	Yes	Critically Endangered	NA
20220419	CT04	1.409626985	103.977587	2022-04-16	4:15:28	IMG_0168.AVI	<i>Tragulus napu</i>	2	Greater mousedeer	Mammal	Least Concern	Critically Endangered	Yes	Critically Endangered	NA
20220419	CT04	1.409626985	103.977587	2022-04-18	15:57:02	IMG_0184.AVI	<i>Varanus sp.</i>	1	NA	Reptile	NA	NA	NA	NA	maybe nebulosus
20220223	CT05	1.409763023	103.978847	2022-02-19	9:19:58	IMG_0187.AVI	<i>Varanus salvator</i>	1	Malayan water monitor	Reptile	Least Concern; Critically Endangered	Least Concern	No	NA	NA
20220223	CT05	1.409763023	103.978847	2022-02-19	11:20:10	IMG_0194.AVI	<i>Varanus salvator</i>	1	Malayan water monitor	Reptile	Least Concern; Critically Endangered	Least Concern	No	NA	NA
20220223	CT05	1.409763023	103.978847	2022-02-19	11:20:32	IMG_0195.AVI	<i>Varanus salvator</i>	1	Malayan water monitor	Reptile	Least Concern; Critically Endangered	Least Concern	No	NA	NA
20220223	CT05	1.409763023	103.978847	2022-02-20	18:01:08	IMG_0254.AVI	<i>Sus scrofa</i>	1	Eurasian wild boar	Mammal	Least Concern	Least Concern	No	NA	NA
20220223	CT05	1.409763023	103.978847	2022-02-20	18:49:54	IMG_0257.AVI	<i>Copsychus saularis</i>	1	Oriental magpie-robin	Bird	Least Concern	Endangered	Yes	Endangered	NA
20220223	CT05	1.409763023	103.978847	2022-02-21	9:56:04	IMG_0260.AVI	<i>Sus scrofa</i>	1	Eurasian wild boar	Mammal	Least Concern	Least Concern	No	NA	NA
20220329	CT05	1.409763023	103.978847	2022-02-24	0:22:54	IMG_0067.AVI	<i>Sus scrofa</i>	1	Eurasian wild boar	Mammal	Least Concern	Least Concern	No	NA	NA
20220329	CT05	1.409763023	103.978847	2022-02-24	8:15:44	IMG_0098.AVI	<i>Sus scrofa</i>	1	Eurasian wild boar	Mammal	Least Concern	Least Concern	No	NA	NA
20220329	CT05	1.409763023	103.978847	2022-02-24	19:56:02	IMG_0124.AVI	<i>Sus scrofa</i>	1	Eurasian wild boar	Mammal	Least Concern	Least Concern	No	NA	NA
20220329	CT05	1.409763023	103.978847	2022-02-24	19:56:24	IMG_0125.AVI	<i>Sus scrofa</i>	1	Eurasian wild boar	Mammal	Least Concern	Least Concern	No	NA	NA
20220329	CT05	1.409763023	103.978847	2022-02-24	20:57:54	IMG_0126.AVI	<i>Sus scrofa</i>	1	Eurasian wild boar	Mammal	Least Concern	Least Concern	No	NA	NA
20220329	CT05	1.409763023	103.978847	2022-02-24	8:16:04	IMG_0099.AVI	<i>Sus scrofa</i>	2	Eurasian wild boar	Mammal	Least Concern	Least Concern	No	NA	NA
20220329	CT05	1.409763023	103.978847	2022-02-24	8:16:26	IMG_0100.AVI	<i>Sus scrofa</i>	2	Eurasian wild boar	Mammal	Least Concern	Least Concern	No	NA	NA
20220329	CT05	1.409763023	103.978847	2022-02-24	21:10:10	IMG_0128.AVI	<i>Tragulus napu</i>	1	Greater mousedeer	Mammal	Least Concern	Critically Endangered	Yes	Critically Endangered	NA
20220329	CT05	1.409763023	103.978847	2022-02-24	21:15:36	IMG_0129.AVI	<i>Varanus salvator</i>	1	Malayan water monitor	Reptile	Least Concern; Critically Endangered	Least Concern	No	NA	NA
20220419	CT05	1.409763023	103.978847	2022-03-30	13:48:50	IMG_0016.AVI	<i>Pycnonotus plumosus</i>	1	NA	Bird	Least Concern	Not Assessed	No	NA	NA
20220419	CT05	1.409763023	103.978847	2022-03-30	2:24:24	IMG_0034.AVI	<i>Paradoxurus musangus</i>	1	Sumatran palm civet	Mammal	Least Concern	Least Concern	No	NA	NA
20220419	CT05	1.409763023	103.978847	2022-03-30	7:14:06	IMG_0035.AVI	<i>Sus scrofa</i>	1	Eurasian wild boar	Mammal	Least Concern	Least Concern	No	NA	NA
20220419	CT05	1.409763023	103.978847	2022-04-02	16:55:34	IMG_0043.AVI	<i>Sus scrofa</i>	1	Eurasian wild boar	Mammal	Least Concern	Least Concern	No	NA	NA
20220419	CT05	1.409763023	103.978847	2022-04-03	23:58:50	IMG_0044.AVI	<i>Paradoxurus musangus</i>	1	Sumatran palm civet	Mammal	Least Concern	Least Concern	No	NA	NA
20220419	CT05	1.409763023	103.978847	2022-04-05	13:43:18	IMG_0045.AVI	<i>Sus scrofa</i>	2	Eurasian wild boar	Mammal	Least Concern	Least Concern	No	NA	NA
20220419	CT05	1.409763023	103.978847	2022-04-05	13:43:44	IMG_0046.AVI	<i>Sus scrofa</i>	2	Eurasian wild boar	Mammal	Least Concern	Least Concern	No	NA	NA
20220419	CT05	1.409763023	103.978847	2022-04-05	18:32:40	IMG_0047.AVI	<i>Sus scrofa</i>	1	Eurasian wild boar	Mammal	Least Concern	Least Concern	No	NA	NA
20220419	CT05	1.409763023	103.978847	2022-04-05	19:09:38	IMG_0048.AVI	<i>Sus scrofa</i>	1	Eurasian wild boar	Mammal	Least Concern	Least Concern	No	NA	NA
20220419	CT05	1.409763023	103.978847	2022-04-06	10:53:52	IMG_0049.AVI	<i>Sus scrofa</i>	1	Eurasian wild boar	Mammal	Least Concern	Least Concern	No	NA	NA
20220419	CT05	1.409763023	103.978847	2022-04-07	9:52:46	IMG_0050.AVI	<i>Sus scrofa</i>	1	Eurasian wild boar	Mammal	Least Concern	Least Concern	No	NA	NA
20220419	CT05	1.409763023	103.978847	2022-04-09	16:13:18	IMG_0052.AVI	<i>Copsychus saularis</i>	1	Oriental magpie-robin	Bird	Least Concern	Endangered	Yes	Endangered	NA
20220419	CT05	1.409763023	103.978847	2022-04-09	19:30:34	IMG_0053.AVI	<i>Sus scrofa</i>	1	Eurasian wild boar	Mammal	Least Concern	Least Concern	No	NA	NA
20220419	CT05	1.409763023	103.978847	2022-04-11	16:33:22	IMG_0054.AVI	<i>Sus scrofa</i>	1	Eurasian wild boar	Mammal	Least Concern	Least Concern	No	NA	NA
20220419	CT05	1.409763023	103.978847	2022-04-11	19:23:56	IMG_0055.AVI	<i>Sus scrofa</i>	1	Eurasian wild boar	Mammal	Least Concern	Least Concern	No	NA	NA
20220419	CT05	1.409763023	103.978847	2022-04-11	7:52:22	IMG_0056.AVI	<i>Sus scrofa</i>	1	Eurasian wild boar	Mammal	Least Concern	Least Concern	No	NA	NA
20220419	CT05	1.409763023	103.978847	2022-04-13	12:33:26	IMG_0057.AVI	<i>Pitta sp.</i>	1	NA	Bird	NA	NA	NA	NA	bluewingormangrove
20220419	CT05	1.409763023	103.978847	2022-04-13	19:43:46	IMG_0058.AVI	<i>Tragulus napu</i>	1	Greater mousedeer	Mammal	Least Concern	Critically Endangered	Yes	Critically Endangered	NA
20220419	CT05	1.409763023	103.978847	2022-04-16	10:36:12	IMG_0059.AVI	<i>Amauromis phoenicurus</i>	1	White-breasted waterfowl	Bird	Least Concern	Not Assessed	No	NA	NA
20220419	CT05	1.409763023	103.978847	2022-04-16	13:11:50	IMG_0060.AVI	<i>Pitta sp.</i>	1	NA	Bird	NA	NA	NA	NA	bluewingormangrove
20220419	CT05	1.409763023	103.978847	2022-04-18	6:07:24	IMG_0061.AVI	<i>Tragulus napu</i>	1	Greater mousedeer	Mammal	Least Concern	Critically Endangered	Yes	Critically Endangered	NA

Appendix H
Impact Assessment on
Habitat, Plants and
Fauna Receptors

Receptor Type	Type	Habitat	Phase	Impact type	Sensitivity (S)	Impact intensity (I)	Consequence (C = S x I)	Likelihood (L)	Impact significance (C x L)	Residual impact intensity	Residual consequence	Residual likelihood	Residual impact significance
Habitat	Terrestrial	Mangrove	Construction	Habitat degradation	High	Medium	Medium	Unlikely	Negligible	Medium	Medium	Unlikely	Negligible
Habitat	Terrestrial	Abandoned-land forest	Construction	Habitat degradation	Medium	Medium	Low	Unlikely	Negligible	Medium	Low	Unlikely	Negligible
Habitat	Marine	Marine area	Construction	Habitat degradation	Medium	Low	Very Low	Likely	Minor	Low	Very Low	Likely	Minor
Habitat	Terrestrial	Scrubland and herbaceous vegetation	Construction	Habitat degradation	Medium	High	Medium	Unlikely	Negligible	High	Medium	Unlikely	Negligible
Habitat	Marine	Soft-sediment seabed	Construction	Habitat degradation	Medium	Medium	Low	Likely	Moderate	Medium	Low	Less likely	Minor
Habitat	Terrestrial	Mangrove	Construction	Loss of vegetation/habitat	High	Negligible	Very Low	Unlikely	Negligible	Negligible	Very Low	Unlikely	Negligible
Habitat	Terrestrial	Abandoned-land forest	Construction	Loss of vegetation/habitat	Medium	Low	Very Low	Certain	Minor	Low	Very Low	Certain	Minor
Habitat	Marine	Marine area	Construction	Loss of vegetation/habitat	Medium	Negligible	Imperceptible	Unlikely	Negligible	Negligible	Imperceptible	Unlikely	Negligible
Habitat	Terrestrial	Scrubland and herbaceous vegetation	Construction	Loss of vegetation/habitat	Medium	Low	Very Low	Certain	Minor	Low	Very Low	Certain	Minor
Habitat	Marine	Soft-sediment seabed	Construction	Loss of vegetation/habitat	Medium	High	Medium	Certain	Major	High	Medium	Certain	Major
Habitat	Terrestrial	Mangrove	Operational	Habitat degradation	High	Low	Low	Less likely	Minor	Low	Low	Less likely	Minor
Habitat	Terrestrial	Abandoned-land forest	Operational	Habitat degradation	Medium	Low	Very Low	Less likely	Negligible	Low	Very Low	Less likely	Negligible
Habitat	Marine	Marine area	Operational	Habitat degradation	Medium	Low	Very Low	Unlikely	Negligible	Low	Very Low	Unlikely	Negligible
Habitat	Terrestrial	Scrubland and herbaceous vegetation	Operational	Habitat degradation	Medium	Low	Very Low	Less likely	Negligible	Low	Very Low	Less likely	Negligible
Habitat	Marine	Soft-sediment seabed	Operational	Habitat degradation	Medium	NA	NA	NA	NA	NA	NA	NA	NA

Receptor Type	Species	Family	Origin	Status	Habit	Phase	Impact type	Sensitivity (S)	Impact intensity (I)	Consequence (C = S x I)	Likelihood (L)	Impact significance (C x L)	Residual impact intensity	Residual consequence	Residual likelihood	Residual impact significance
Flora	<i>Licuala spinosa</i>	Arecaceae	Native	Vulnerable	Shrub	Construction	Decline in plant health	High	Low	Low	Unlikely	Negligible	Low	Low	Unlikely	Negligible
Flora	<i>Nypa fruticans</i>	Arecaceae	Native	Vulnerable	Shrub	Construction	Decline in plant health	High	Low	Low	Unlikely	Negligible	Low	Low	Unlikely	Negligible
Flora	<i>Trema tomentosa</i>	Cannabaceae	Native	Vulnerable	Shrub	Construction	Decline in plant health	High	Low	Low	Unlikely	Negligible	Low	Low	Unlikely	Negligible
Flora	<i>Gona heterocarpos var. strigosa</i>	Fabaceae	Native	Vulnerable	Shrub	Construction	Decline in plant health	High	Low	Low	Unlikely	Negligible	Low	Low	Unlikely	Negligible
Flora	<i>Utania nervosa</i>	Gentianaceae	Native	Vulnerable	Tree	Construction	Decline in plant health	High	Low	Low	Unlikely	Negligible	Low	Low	Unlikely	Negligible
Flora	<i>Gnetum sp. (Climber)</i>	Gnetaceae	Native	Critically Endangered	Climber	Construction	Decline in plant health	High	Low	Low	Unlikely	Negligible	Low	Low	Unlikely	Negligible
Flora	<i>Litsea myristicifolia</i>	Lauraceae	Native	Critically Endangered	Tree	Construction	Decline in plant health	High	Low	Low	Unlikely	Negligible	Low	Low	Unlikely	Negligible
Flora	<i>Neollitsea cassia</i>	Lauraceae	Native	Vulnerable	Tree	Construction	Decline in plant health	High	Low	Low	Unlikely	Negligible	Low	Low	Unlikely	Negligible
Flora	<i>Tristellateia australasica</i>	Malpighiaceae	Native	Endangered	Climber	Construction	Decline in plant health	High	Low	Low	Unlikely	Negligible	Low	Low	Unlikely	Negligible
Flora	<i>Mercycylon edule var. edule</i>	Melastomataceae	Native	Endangered	Tree	Construction	Decline in plant health	High	Low	Low	Unlikely	Negligible	Low	Low	Unlikely	Negligible
Flora	<i>Ficus cf. stricta</i>	Moraceae	Native	Critically Endangered	Tree	Construction	Decline in plant health	High	Low	Low	Unlikely	Negligible	Low	Low	Unlikely	Negligible
Flora	<i>Knema corticosa</i>	Myristicaceae	Native	Vulnerable	Tree	Construction	Decline in plant health	High	Low	Low	Unlikely	Negligible	Low	Low	Unlikely	Negligible
Flora	<i>Syzygium pycnanthum</i>	Myrtaceae	Native	Critically Endangered	Tree	Construction	Decline in plant health	High	Low	Low	Unlikely	Negligible	Low	Low	Unlikely	Negligible
Flora	<i>Syzygium syzygioides</i>	Myrtaceae	Native	Vulnerable	Tree	Construction	Decline in plant health	High	Low	Low	Unlikely	Negligible	Low	Low	Unlikely	Negligible
Flora	<i>Cansjera rheedi</i>	Opliaceae	Native	Vulnerable	Climber	Construction	Decline in plant health	High	Low	Low	Unlikely	Negligible	Low	Low	Unlikely	Negligible
Flora	<i>Antidesma velutinosum</i>	Phyllanthaceae	Native	Endangered	Tree	Construction	Decline in plant health	High	Low	Low	Unlikely	Negligible	Low	Low	Unlikely	Negligible
Flora	<i>Bridelia stipularis</i>	Phyllanthaceae	Native	Vulnerable	Shrub	Construction	Decline in plant health	High	Low	Low	Unlikely	Negligible	Low	Low	Unlikely	Negligible
Flora	<i>Cyrtocarpus patens</i>	Poaceae	Native	Vulnerable	Herb	Construction	Decline in plant health	High	Low	Low	Unlikely	Negligible	Low	Low	Unlikely	Negligible
Flora	<i>Ardisia elliptica</i>	Primulaceae	Native	Endangered	Tree	Construction	Decline in plant health	High	Low	Low	Unlikely	Negligible	Low	Low	Unlikely	Negligible
Flora	<i>Ocyeros longiflorus</i>	Rubiaceae	Native	Vulnerable	Climber	Construction	Decline in plant health	High	Low	Low	Unlikely	Negligible	Low	Low	Unlikely	Negligible
Flora	<i>Planchonella obovata</i>	Sapotaceae	Native	Vulnerable	Tree	Construction	Decline in plant health	High	Low	Low	Unlikely	Negligible	Low	Low	Unlikely	Negligible
Flora	<i>Desmos dasymaschala</i>	#N/A	#N/A	#N/A	#N/A	Construction	Decline in plant health	High	Low	Low	Unlikely	Negligible	Low	Low	Unlikely	Negligible
Flora	<i>Sauroups baciformis</i>	#N/A	#N/A	#N/A	#N/A	Construction	Decline in plant health	High	Low	Low	Unlikely	Negligible	Low	Low	Unlikely	Negligible
Flora	<i>Lumnitzera littorea</i>	Combretaceae	Native	Endangered	Tree	Construction	Decline in plant health	High	Medium	Medium	Likely	Moderate	Negligible	Very Low	Unlikely	Negligible
Flora	<i>Lumnitzera racemosa</i>	Combretaceae	Native	Endangered	Tree	Construction	Decline in plant health	High	Medium*	Medium	Likely	Moderate	Negligible	Very Low	Unlikely	Negligible
Flora	<i>Cerlops tagal</i>	Rhizophoraceae	Native	Vulnerable	Tree	Construction	Decline in plant health	High	Medium	Medium	Likely	Moderate	Negligible	Very Low	Unlikely	Negligible
Flora	<i>Cerlops zippeliana</i>	Rhizophoraceae	Native	Endangered	Tree	Construction	Decline in plant health	High	Medium	Medium	Likely	Moderate	Negligible	Very Low	Unlikely	Negligible
Flora	<i>Halophila ovalis</i>	Hydrocharitaceae	Native	Common	Seagrass	Construction	Decline in plant health	High	NA	NA	NA	NA	NA	NA	NA	NA
Flora	<i>Avicennia alba</i>	Acanthaceae	Native	Common	Tree	Construction	Decline in plant health	High	Negligible	Very Low	Unlikely	Negligible	Negligible	Very Low	Unlikely	Negligible
Flora	<i>Avicennia officinalis</i>	Acanthaceae	Native	Common	Tree	Construction	Decline in plant health	High	Negligible	Very Low	Unlikely	Negligible	Negligible	Very Low	Unlikely	Negligible
Flora	<i>Avicennia rumphiana</i>	Acanthaceae	Native	Common	Tree	Construction	Decline in plant health	High	Negligible	Very Low	Unlikely	Negligible	Negligible	Very Low	Unlikely	Negligible
Flora	<i>Dolichandrone spathacea</i>	Bignoniaceae	Native	Critically Endangered	Tree	Construction	Decline in plant health	High	Negligible	Very Low	Unlikely	Negligible	Negligible	Very Low	Unlikely	Negligible
Flora	<i>Casuarina equisetifolia</i>	Casuarinaceae	Native	Common	Tree	Construction	Decline in plant health	High	Negligible	Very Low	Unlikely	Negligible	Negligible	Very Low	Unlikely	Negligible
Flora	<i>Excoecaria agallocha</i>	Euphorbiaceae	Native	Common	Tree	Construction	Decline in plant health	High	Negligible	Very Low	Unlikely	Negligible	Negligible	Very Low	Unlikely	Negligible
Flora	<i>Cyrtophyllum fragrans</i>	Gentianaceae	Native	Common	Tree	Construction	Decline in plant health	High	Negligible	Very Low	Unlikely	Negligible	Negligible	Very Low	Unlikely	Negligible
Flora	<i>Sonneratia alba</i>	Lythraceae	Native	Common	Tree	Construction	Decline in plant health	High	Negligible	Very Low	Unlikely	Negligible	Negligible	Very Low	Unlikely	Negligible
Flora	<i>Xylocarpus granatum</i>	Meliaceae	Native	Common	Tree	Construction	Decline in plant health	High	Negligible	Very Low	Unlikely	Negligible	Negligible	Very Low	Unlikely	Negligible
Flora	<i>Ficus caulocarpa</i>	Moraceae	Native	Endangered	Strangler	Construction	Decline in plant health	High	Negligible	Very Low	Unlikely	Negligible	Negligible	Very Low	Unlikely	Negligible
Flora	<i>Ficus microcarpa</i>	Moraceae	Native	Common	Tree	Construction	Decline in plant health	High	Negligible	Very Low	Unlikely	Negligible	Negligible	Very Low	Unlikely	Negligible
Flora	<i>Acrostichum aureum</i>	Pteridaceae	Native	Common	Shrub	Construction	Decline in plant health	High	Negligible	Very Low	Unlikely	Negligible	Negligible	Very Low	Unlikely	Negligible
Flora	<i>Bruguiera cylindrica</i>	Rhizophoraceae	Native	Common	Tree	Construction	Decline in plant health	High	Negligible	Very Low	Unlikely	Negligible	Negligible	Very Low	Unlikely	Negligible
Flora	<i>Bruguiera gymnorhiza</i>	Rhizophoraceae	Native	Common	Tree	Construction	Decline in plant health	High	Negligible	Very Low	Unlikely	Negligible	Negligible	Very Low	Unlikely	Negligible
Flora	<i>Rhizophora apiculata</i>	Rhizophoraceae	Native	Common	Tree	Construction	Decline in plant health	High	Negligible	Very Low	Unlikely	Negligible	Negligible	Very Low	Unlikely	Negligible
Flora	<i>Rhizophora mucronata</i>	Rhizophoraceae	Native	Common	Tree	Construction	Decline in plant health	High	Negligible	Very Low	Unlikely	Negligible	Negligible	Very Low	Unlikely	Negligible
Flora	<i>Scyphiphora hydrophyllacea</i>	Rubiaceae	Native	Endangered	Tree	Construction	Decline in plant health	High	Negligible	Very Low	Unlikely	Negligible	Negligible	Very Low	Unlikely	Negligible
Flora	<i>Halophila ovalis</i>	Hydrocharitaceae	Native	Common	Seagrass	Construction	Mortality	Medium	Medium*	Low	Certain	Moderate	Low	Low	Certain	Moderate
Flora	<i>Avicennia alba</i>	Acanthaceae	Native	Common	Tree	Construction	Mortality	High	Negligible	Very Low	Unlikely	Negligible	Negligible	Very Low	Unlikely	Negligible
Flora	<i>Avicennia officinalis</i>	Acanthaceae	Native	Common	Tree	Construction	Mortality	High	Negligible	Very Low	Unlikely	Negligible	Negligible	Very Low	Unlikely	Negligible
Flora	<i>Avicennia rumphiana</i>	Acanthaceae	Native	Common	Tree	Construction	Mortality	High	Negligible	Very Low	Unlikely	Negligible	Negligible	Very Low	Unlikely	Negligible
Flora	<i>Dasymaschalon dasymaschalon</i>	Annonaceae	Native	Critically Endangered	Shrub	Construction	Mortality	High	Negligible	Very Low	Unlikely	Negligible	Negligible	Very Low	Unlikely	Negligible
Flora	<i>Licuala spinosa</i>	Arecaceae	Native	Vulnerable	Shrub	Construction	Mortality	High	Negligible	Very Low	Unlikely	Negligible	Negligible	Very Low	Unlikely	Negligible
Flora	<i>Nypa fruticans</i>	Arecaceae	Native	Vulnerable	Shrub	Construction	Mortality	High	Negligible	Very Low	Unlikely	Negligible	Negligible	Very Low	Unlikely	Negligible
Flora	<i>Dolichandrone spathacea</i>	Bignoniaceae	Native	Critically Endangered	Tree	Construction	Mortality	High	Negligible	Very Low	Unlikely	Negligible	Negligible	Very Low	Unlikely	Negligible
Flora	<i>Trema tomentosa</i>	Cannabaceae	Native	Vulnerable	Shrub	Construction	Mortality	High	Negligible	Very Low	Unlikely	Negligible	Negligible	Very Low	Unlikely	Negligible
Flora	<i>Casuarina equisetifolia</i>	Casuarinaceae	Native	Common	Tree	Construction	Mortality	High	Negligible	Very Low	Unlikely	Negligible	Negligible	Very Low	Unlikely	Negligible
Flora	<i>Lumnitzera littorea</i>	Combretaceae	Native	Endangered	Tree	Construction	Mortality	High	Negligible	Very Low	Possible	Minor	Negligible	Very Low	Possible	Minor
Flora	<i>Lumnitzera racemosa</i>	Combretaceae	Native	Endangered	Tree	Construction	Mortality	High	Negligible	Very Low	Possible	Minor	Negligible	Very Low	Possible	Minor
Flora	<i>Excoecaria agallocha</i>	Euphorbiaceae	Native	Common	Tree	Construction	Mortality	High	Negligible	Very Low	Unlikely	Negligible	Negligible	Very Low	Unlikely	Negligible
Flora	<i>Gona heterocarpos var. strigosa</i>	Fabaceae	Native	Vulnerable	Shrub	Construction	Mortality	High	Negligible	Very Low	Unlikely	Negligible	Negligible	Very Low	Unlikely	Negligible
Flora	<i>Cyrtophyllum fragrans</i>	Gentianaceae	Native	Common	Tree	Construction	Mortality	High	Negligible	Very Low	Unlikely	Negligible	Negligible	Very Low	Unlikely	Negligible
Flora	<i>Utania nervosa</i>	Gentianaceae	Native	Vulnerable	Tree	Construction	Mortality	High	Negligible	Very Low	Unlikely	Negligible	Negligible	Very Low	Unlikely	Negligible
Flora	<i>Gnetum sp. (Climber)</i>	Gnetaceae	Native	Critically Endangered	Climber	Construction	Mortality	High	Negligible	Very Low	Unlikely	Negligible	Negligible	Very Low	Unlikely	Negligible
Flora	<i>Litsea myristicifolia</i>	Lauraceae	Native	Critically Endangered	Tree	Construction	Mortality	High	Negligible	Very Low	Unlikely	Negligible	Negligible	Very Low	Unlikely	Negligible
Flora	<i>Neollitsea cassia</i>	Lauraceae	Native	Vulnerable	Tree	Construction	Mortality	High	Negligible	Very Low	Unlikely	Negligible	Negligible	Very Low	Unlikely	Negligible

Receptor Type	Species	Family	Origin	Status	Habit	Phase	Impact type	Sensitivity (S)	Impact intensity (I)	Consequence (C = S x I)	Likelihood (L)	Impact significance (C x L)	Residual impact intensity	Residual consequence	Residual likelihood	Residual impact significance
Flora	<i>Sonneratia alba</i>	Lythraceae	Native	Common	Tree	Construction	Mortality	High	Negligible	Very Low	Unlikely	Negligible	Negligible	Very Low	Unlikely	Negligible
Flora	<i>Tristellateia australasiae</i>	Malpighiaceae	Native	Endangered	Climber	Construction	Mortality	High	Negligible	Very Low	Unlikely	Negligible	Negligible	Very Low	Unlikely	Negligible
Flora	<i>Memecylon edule</i> var. <i>edule</i>	Melastomataceae	Native	Endangered	Tree	Construction	Mortality	High	Negligible	Very Low	Unlikely	Negligible	Negligible	Very Low	Unlikely	Negligible
Flora	<i>Xylocarpus granatum</i>	Meliaceae	Native	Common	Tree	Construction	Mortality	High	Negligible	Very Low	Unlikely	Negligible	Negligible	Very Low	Unlikely	Negligible
Flora	<i>Ficus caulocarpa</i>	Moraceae	Native	Endangered	Strangler	Construction	Mortality	High	Negligible	Very Low	Unlikely	Negligible	Negligible	Very Low	Unlikely	Negligible
Flora	<i>Ficus cf. stricta</i>	Moraceae	Native	Critically Endangered	Tree	Construction	Mortality	High	Negligible	Very Low	Unlikely	Negligible	Negligible	Very Low	Unlikely	Negligible
Flora	<i>Ficus microcarpa</i>	Moraceae	Native	Common	Tree	Construction	Mortality	High	Negligible	Very Low	Unlikely	Negligible	Negligible	Very Low	Unlikely	Negligible
Flora	<i>Knema corticosa</i>	Myristicaceae	Native	Vulnerable	Tree	Construction	Mortality	High	Negligible	Very Low	Unlikely	Negligible	Negligible	Very Low	Unlikely	Negligible
Flora	<i>Syzygium pycnanthum</i>	Myrtaceae	Native	Critically Endangered	Tree	Construction	Mortality	High	Negligible	Very Low	Unlikely	Negligible	Negligible	Very Low	Unlikely	Negligible
Flora	<i>Syzygium syzygioides</i>	Myrtaceae	Native	Vulnerable	Tree	Construction	Mortality	High	Negligible	Very Low	Unlikely	Negligible	Negligible	Very Low	Unlikely	Negligible
Flora	<i>Cansjera rheedii</i>	Oplilaceae	Native	Vulnerable	Climber	Construction	Mortality	High	Negligible	Very Low	Unlikely	Negligible	Negligible	Very Low	Unlikely	Negligible
Flora	<i>Antidesma velutinosum</i>	Phyllanthaceae	Native	Endangered	Tree	Construction	Mortality	High	Negligible	Very Low	Unlikely	Negligible	Negligible	Very Low	Unlikely	Negligible
Flora	<i>Bridelia stipularis</i>	Phyllanthaceae	Native	Vulnerable	Shrub	Construction	Mortality	High	Negligible	Very Low	Unlikely	Negligible	Negligible	Very Low	Unlikely	Negligible
Flora	<i>Synostemon bacciformis</i>	Phyllanthaceae	Native	Critically Endangered	Herb	Construction	Mortality	High	Negligible	Very Low	Unlikely	Negligible	Negligible	Very Low	Unlikely	Negligible
Flora	<i>Cyrtococcum patens</i>	Poaceae	Native	Vulnerable	Herb	Construction	Mortality	High	Negligible	Very Low	Unlikely	Negligible	Negligible	Very Low	Unlikely	Negligible
Flora	<i>Ardisia elliptica</i>	Primulaceae	Native	Endangered	Tree	Construction	Mortality	High	Negligible	Very Low	Unlikely	Negligible	Negligible	Very Low	Unlikely	Negligible
Flora	<i>Acrostichum aureum</i>	Pteridaceae	Native	Common	Shrub	Construction	Mortality	High	Negligible	Very Low	Unlikely	Negligible	Negligible	Very Low	Unlikely	Negligible
Flora	<i>Bruguiera cylindrica</i>	Rhizophoraceae	Native	Common	Tree	Construction	Mortality	High	Negligible	Very Low	Unlikely	Negligible	Negligible	Very Low	Unlikely	Negligible
Flora	<i>Bruguiera gymnorhiza</i>	Rhizophoraceae	Native	Common	Tree	Construction	Mortality	High	Negligible	Very Low	Unlikely	Negligible	Negligible	Very Low	Unlikely	Negligible
Flora	<i>Ceriops tagal</i>	Rhizophoraceae	Native	Vulnerable	Tree	Construction	Mortality	High	Negligible	Very Low	Possible	Minor	Negligible	Very Low	Possible	Minor
Flora	<i>Ceriops zippelliana</i>	Rhizophoraceae	Native	Endangered	Tree	Construction	Mortality	High	Negligible	Very Low	Possible	Minor	Negligible	Very Low	Possible	Minor
Flora	<i>Rhizophora apiculata</i>	Rhizophoraceae	Native	Common	Tree	Construction	Mortality	High	Negligible	Very Low	Unlikely	Negligible	Negligible	Very Low	Unlikely	Negligible
Flora	<i>Rhizophora mucronata</i>	Rhizophoraceae	Native	Common	Tree	Construction	Mortality	High	Negligible	Very Low	Unlikely	Negligible	Negligible	Very Low	Unlikely	Negligible
Flora	<i>Oxyceros longiflorus</i>	Rubiaceae	Native	Vulnerable	Climber	Construction	Mortality	High	Negligible	Very Low	Unlikely	Negligible	Negligible	Very Low	Unlikely	Negligible
Flora	<i>Scyphiphora hydrophyllacea</i>	Rubiaceae	Native	Endangered	Tree	Construction	Mortality	High	Negligible	Very Low	Unlikely	Negligible	Negligible	Very Low	Unlikely	Negligible
Flora	<i>Planchonella obovata</i>	Sapotaceae	Native	Vulnerable	Tree	Construction	Mortality	High	Negligible	Very Low	Unlikely	Negligible	Negligible	Very Low	Unlikely	Negligible

Receptor Type	Type	Species	Taxon	Common name	Global status	National status	Recorded during field assessment?	Phase	Impact type	Sensitivity (S)	Impact Intensity (I)	Consequence (C) = S x I	Likelihood	Impact significance	Residual impact intensity	Residual consequence	Residual likelihood	Residual impact significance
Fauna	Terrestrial	<i>Anthracoceros albirostris</i>	Bird	Oriental pied hornbill	Least Concern	Near Threatened	Yes	Construction	Accidental injury or mortality	High	Low	Low	Unlikely	Negligible	Low	Low	Unlikely	Negligible
Fauna	Terrestrial	<i>Anas chenera</i>	Bird	Gray heron	Least Concern	Least Concern	Yes	Construction	Accidental injury or mortality	High	Low	Low	Unlikely	Negligible	Low	Low	Unlikely	Negligible
Fauna	Terrestrial	<i>Anas sumatrana</i>	Bird	Great billed heron	Least Concern	Critically Endangered	Yes	Construction	Accidental injury or mortality	High	Low	Low	Unlikely	Negligible	Low	Low	Unlikely	Negligible
Fauna	Terrestrial	<i>Coryphus melanocephalus</i>	Bird	Whiterumped shrike	Least Concern	Endangered	Yes	Construction	Accidental injury or mortality	High	Low	Low	Unlikely	Negligible	Low	Low	Unlikely	Negligible
Fauna	Terrestrial	<i>Ceryle melanosomus</i>	Bird	Oriental mallard reedling	Least Concern	Vulnerable	Yes	Construction	Accidental injury or mortality	High	Low	Low	Unlikely	Negligible	Low	Low	Unlikely	Negligible
Fauna	Terrestrial	<i>Merula philippina</i>	Bird	Changsha hawk-eagle	Least Concern	Vulnerable	Yes	Construction	Accidental injury or mortality	High	Low	Low	Unlikely	Negligible	Low	Low	Unlikely	Negligible
Fauna	Terrestrial	<i>Pendulops melanoleucus</i>	Bird	Red-headed bulbul	Critically Endangered	Endangered	Yes	Construction	Accidental injury or mortality	High	Low	Low	Unlikely	Negligible	Low	Low	Unlikely	Negligible
Fauna	Terrestrial	<i>Argemone amphimela amphimela</i>	Butterfly	NA	Not Listed	Nationally Extinct (Rediscovered)	No	Construction	Accidental injury or mortality	High	Low	Low	Unlikely	Negligible	Low	Low	Unlikely	Negligible
Fauna	Terrestrial	<i>Ariadne arafane ariadne</i>	Butterfly	Angled castor	Not Listed	Nationally Extinct (Rediscovered)	No	Construction	Accidental injury or mortality	High	Low	Low	Unlikely	Negligible	Low	Low	Unlikely	Negligible
Fauna	Terrestrial	<i>Asiaticopterus jama jama</i>	Butterfly	Forest hopper	Not Listed	Nationally Extinct (Rediscovered)	No	Construction	Accidental injury or mortality	High	Low	Low	Unlikely	Negligible	Low	Low	Unlikely	Negligible
Fauna	Terrestrial	<i>Bombus cinerarius</i>	Butterfly	Formosan swift	Not Listed	Endangered	No	Construction	Accidental injury or mortality	High	Low	Low	Unlikely	Negligible	Low	Low	Unlikely	Negligible
Fauna	Terrestrial	<i>Calotis malaya</i>	Butterfly	Malayan swift	Not Listed	Nationally Extinct (Rediscovered)	No	Construction	Accidental injury or mortality	High	Low	Low	Unlikely	Negligible	Low	Low	Unlikely	Negligible
Fauna	Terrestrial	<i>Catopygia ancyra</i>	Butterfly	Anvora blue	Not Listed	Vulnerable	No	Construction	Accidental injury or mortality	High	Low	Low	Unlikely	Negligible	Low	Low	Unlikely	Negligible
Fauna	Terrestrial	<i>Coleanohinus amara amara</i>	Butterfly	White banded flat	Not Listed	Nationally Extinct (Rediscovered)	No	Construction	Accidental injury or mortality	High	Low	Low	Unlikely	Negligible	Low	Low	Unlikely	Negligible
Fauna	Terrestrial	<i>Cephaelis acallinastus</i>	Butterfly	Plain palm dart	Not Listed	Nationally Extinct (Rediscovered)	No	Construction	Accidental injury or mortality	High	Low	Low	Unlikely	Negligible	Low	Low	Unlikely	Negligible
Fauna	Terrestrial	<i>Cephaelis meliphaea</i>	Butterfly	Plain lacewing	Not Listed	Critically Endangered	No	Construction	Accidental injury or mortality	High	Low	Low	Unlikely	Negligible	Low	Low	Unlikely	Negligible
Fauna	Terrestrial	<i>Diopthra sandaka desipulata</i>	Butterfly	Common duffer	Not Listed	Critically Endangered	No	Construction	Accidental injury or mortality	High	Low	Low	Unlikely	Negligible	Low	Low	Unlikely	Negligible
Fauna	Terrestrial	<i>Musa lucasone chersonesa</i>	Butterfly	Mangrove tree nymph	Not Listed	Critically Endangered	No	Construction	Accidental injury or mortality	High	Low	Low	Unlikely	Negligible	Low	Low	Unlikely	Negligible
Fauna	Terrestrial	<i>Janina allecto agelada</i>	Butterfly	Metallic caerulean	Not Listed	Nationally Extinct (Rediscovered)	No	Construction	Accidental injury or mortality	High	Low	Low	Unlikely	Negligible	Low	Low	Unlikely	Negligible
Fauna	Terrestrial	<i>Nacaduba kuvana nemana</i>	Butterfly	Transparent satirine blue	Not Listed	Nationally Extinct (Rediscovered)	No	Construction	Accidental injury or mortality	High	Low	Low	Unlikely	Negligible	Low	Low	Unlikely	Negligible
Fauna	Terrestrial	<i>Nacaduba pactilus odon</i>	Butterfly	Large fourline blue	Not Listed	Nationally Extinct (Rediscovered)	No	Construction	Accidental injury or mortality	High	Low	Low	Unlikely	Negligible	Low	Low	Unlikely	Negligible
Fauna	Terrestrial	<i>Pachlopa aristobolus aristobolus</i>	Butterfly	Common rose	Not Listed	Vulnerable	No	Construction	Accidental injury or mortality	High	Low	Low	Unlikely	Negligible	Low	Low	Unlikely	Negligible
Fauna	Terrestrial	<i>Pantoclis aspasia aspasia</i>	Butterfly	Yellow glassy tiger	Not Listed	Nationally Extinct (Rediscovered)	No	Construction	Accidental injury or mortality	High	Low	Low	Unlikely	Negligible	Low	Low	Unlikely	Negligible
Fauna	Terrestrial	<i>Pantoclis valeria lufuzero</i>	Butterfly	Wanderer	Not Listed	Nationally Extinct (Rediscovered)	No	Construction	Accidental injury or mortality	High	Low	Low	Unlikely	Negligible	Low	Low	Unlikely	Negligible
Fauna	Terrestrial	<i>Polyommata agna agna</i>	Butterfly	Bengal swift	Not Listed	Endangered	No	Construction	Accidental injury or mortality	High	Low	Low	Unlikely	Negligible	Low	Low	Unlikely	Negligible
Fauna	Terrestrial	<i>Polioptilus zambala tyleri</i>	Butterfly	Seashed dart	Not Listed	Nationally Extinct (Rediscovered)	No	Construction	Accidental injury or mortality	High	Low	Low	Unlikely	Negligible	Low	Low	Unlikely	Negligible
Fauna	Terrestrial	<i>Rachana jalindra burbona</i>	Butterfly	Banded royal	Not Listed	Critically Endangered	No	Construction	Accidental injury or mortality	High	Low	Low	Unlikely	Negligible	Low	Low	Unlikely	Negligible
Fauna	Terrestrial	<i>Suzuka everax everax</i>	Butterfly	White palm bob	Not Listed	Endangered	No	Construction	Accidental injury or mortality	High	Low	Low	Unlikely	Negligible	Low	Low	Unlikely	Negligible
Fauna	Terrestrial	<i>Fotocla colon stinga</i>	Butterfly	Common palm dart	Not Listed	Nationally Extinct (Rediscovered)	No	Construction	Accidental injury or mortality	High	Low	Low	Unlikely	Negligible	Low	Low	Unlikely	Negligible
Fauna	Terrestrial	<i>Trochus helena corburni</i>	Butterfly	Common birdwing	Not Listed	Vulnerable	No	Construction	Accidental injury or mortality	High	Low	Low	Unlikely	Negligible	Low	Low	Unlikely	Negligible
Fauna	Terrestrial	<i>Euptonia talialis adorum</i>	Butterfly	Black cow	Not Listed	Endangered	Yes	Construction	Accidental injury or mortality	High	Low	Low	Unlikely	Negligible	Low	Low	Unlikely	Negligible
Fauna	Terrestrial	<i>Grahamia fusca everestensis</i>	Butterfly	Common Jay	Not Listed	Not Evaluated	Yes	Construction	Accidental injury or mortality	High	Low	Low	Unlikely	Negligible	Low	Low	Unlikely	Negligible
Fauna	Terrestrial	<i>Polyura moori moori</i>	Butterfly	Malayan nawab	Not Listed	Nationally Extinct (Rediscovered)	Yes	Construction	Accidental injury or mortality	High	Low	Low	Unlikely	Negligible	Low	Low	Unlikely	Negligible
Fauna	Terrestrial	<i>Mordania arbuti</i>	Damselfly	Arthur's midget	Near Threatened	Vulnerable	Yes	Construction	Accidental injury or mortality	High	Low	Low	Unlikely	Negligible	Negligible	Very Low	Unlikely	Minor
Fauna	Terrestrial	<i>Anas puyupuy</i>	Diapryid	Wetland emperor	Least Concern	Least Concern	No	Construction	Accidental injury or mortality	High	Low	Low	Unlikely	Negligible	Negligible	Very Low	Unlikely	Minor
Fauna	Terrestrial	<i>Chromis mossambicus</i>	Fish	Common Moorish wrasse	Least Concern	Not Evaluated	Yes	Construction	Accidental injury or mortality	High	Low	Low	Unlikely	Negligible	Negligible	Very Low	Unlikely	Minor
Fauna	Terrestrial	<i>Thalassia anomala</i>	Mollusk	Mud lobster	Not Listed	Endangered	NA	Construction	Accidental injury or mortality	High	Low	Low	Unlikely	Negligible	Negligible	High	Unlikely	Minor
Fauna	Terrestrial	<i>Thalassia gracilis</i>	Mollusk	Mud lobster	Not Listed	Endangered	NA	Construction	Accidental injury or mortality	High	Low	Low	Unlikely	Negligible	Negligible	High	Unlikely	Minor
Fauna	Terrestrial	<i>Wolffia philippensis</i>	NA	NA	Not Listed	Endangered	NA	Construction	Accidental injury or mortality	High	Low	Low	Unlikely	Negligible	Negligible	High	Unlikely	Minor
Fauna	Terrestrial	<i>Aonyx chinensis</i>	Non-marine mammal	Oriental small-clawed otter	Vulnerable	Critically Endangered	No	Construction	Accidental injury or mortality	High	High	High	Unlikely	Negligible	Negligible	Very Low	Unlikely	Negligible
Fauna	Terrestrial	<i>Myotis brachyura</i>	Non-marine mammal	Malayan caprimulgum	Least Concern	Critically Endangered	No	Construction	Accidental injury or mortality	High	High	High	Unlikely	Negligible	Negligible	Very Low	Unlikely	Negligible
Fauna	Terrestrial	<i>Manis javanica</i>	Non-marine mammal	Sunda pangolin	Critically Endangered	Critically Endangered	No	Construction	Accidental injury or mortality	High	High	High	Unlikely	Negligible	Negligible	Very Low	Unlikely	Negligible
Fauna	Terrestrial	<i>Lufousia pongaiflata</i>	Non-marine mammal	Smooth otter	Vulnerable	Endangered	Yes	Construction	Accidental injury or mortality	High	High	High	Unlikely	Negligible	Negligible	Very Low	Unlikely	Negligible
Fauna	Terrestrial	<i>Macrogale fasciatus</i>	Non-marine mammal	Long-billed treeshrew	Endangered	Least Concern	Yes	Construction	Accidental injury or mortality	High	High	High	Unlikely	Negligible	Negligible	Very Low	Unlikely	Negligible
Fauna	Terrestrial	<i>Prionailurus bengalensis</i>	Non-marine mammal	opard cat	Least Concern	Critically Endangered	Yes	Construction	Accidental injury or mortality	High	High	High	Unlikely	Negligible	Negligible	Very Low	Unlikely	Negligible
Fauna	Terrestrial	<i>Tragulus napu</i>	Non-marine mammal	Greater mousdeer	Least Concern	Critically Endangered	Yes	Construction	Accidental injury or mortality	High	High	High	Unlikely	Negligible	Negligible	Very Low	Unlikely	Negligible
Fauna	Terrestrial	<i>Boiga cyonodon</i>	Non-marine snake	Boa booted cat snake	Least Concern	Vulnerable	Yes	Construction	Accidental injury or mortality	High	High	High	Unlikely	Negligible	Negligible	Very Low	Unlikely	Negligible
Fauna	Terrestrial	<i>Boiga melanota</i>	Non-marine snake	Gold striped cat snake	Least Concern	Vulnerable	Yes	Construction	Accidental injury or mortality	High	High	High	Unlikely	Negligible	Negligible	Very Low	Unlikely	Negligible
Fauna	Terrestrial	<i>Bungarus fasciatus</i>	Non-marine snake	Banded krait	Least Concern	Endangered	Yes	Construction	Accidental injury or mortality	High	High	High	Unlikely	Negligible	Negligible	Very Low	Unlikely	Negligible
Fauna	Terrestrial	<i>Dryophis rubicinctus</i>	Non-marine snake	Keel bellied whip snake	Least Concern	Endangered	Yes	Construction	Accidental injury or mortality	High	High	High	Unlikely	Negligible	Negligible	Very Low	Unlikely	Negligible
Fauna	Terrestrial	<i>Spizopis mucronatus</i>	Non-marine snake	Black headed collared snake	Least Concern	Endangered	Yes	Construction	Accidental injury or mortality	High	High	High	Unlikely	Negligible	Negligible	Very Low	Unlikely	Negligible
Fauna	Terrestrial	<i>Tremasurus purpuronaculatus</i>	Non-marine snake	Shore pit viper	Least Concern	Vulnerable	No	Construction	Accidental injury or mortality	High	High	High	Unlikely	Negligible	Negligible	Very Low	Unlikely	Negligible
Fauna	Terrestrial	<i>Argyrophis muelleri</i>	Non-marine snake	White-bellied blind snake	Least Concern	Critically Endangered	Yes	Construction	Accidental injury or mortality	High	High	High	Unlikely	Negligible	Negligible	Very Low	Unlikely	Negligible
Fauna	Terrestrial	<i>Cura amboinensis</i>	Non-marine turtle	Malayan box terrapin	Endangered	Near Threatened	No	Construction	Accidental injury or mortality	High	High	High	Unlikely	Negligible	Negligible	Very Low	Unlikely	Negligible
Fauna	Marine	<i>Forsteria gestapo</i>	Freshwater gastropod	Freshwater gastropod	Least Concern	Vulnerable	No	Construction	Human disturbances	High	Negligible	Very Low	Unlikely	Negligible	Negligible	Very Low	Unlikely	Negligible
Fauna	Marine	<i>Gynerulus bakeri</i>	Freshwater gastropod	Freshwater gastropod	Least Concern	Not Assessed	NA	Construction	Human disturbances	High	Negligible	Very Low	Unlikely	Negligible	Negligible	Very Low	Unlikely	Negligible
Fauna	Marine	<i>Heteropoda opax</i>	Horseshoe crab	Horseshoe crab	Data Deficient	Endangered	NA	Construction	Human disturbances	High	Negligible	Very Low	Unlikely	Negligible	Negligible	Very Low	Unlikely	Negligible
Fauna	Marine	<i>Caridiodorops philippinensis</i>	Horseshoe crab	Horseshoe crab	Not Assessed	Vulnerable	Yes	Construction	Human disturbances	High	Negligible	Very Low	Unlikely	Negligible	Negligible	Very Low	Unlikely	Negligible
Fauna	Marine	<i>Pinna bicolor</i>	Marine bivalve	Two-coloured fan shell	Not Assessed	Vulnerable	NA	Construction	Human disturbances	High	Negligible	Very Low	Unlikely	Negligible	Negligible	Very Low	Unlikely	Negligible
Fauna	Marine	<i>Pinna incurva</i>	Marine bivalve	Fan mussel	Critically Endangered	Not Assessed	NA	Construction	Human disturbances	High	Negligible	Very Low	Unlikely	Negligible	Negligible	Very Low	Unlikely	Negligible
Fauna	Marine	<i>Tridacna squarosa</i>	Marine bivalve	Ruffled giant clam	Not Assessed	CITES protected (Appendix II)	NA	Construction	Human disturbances	High	Negligible	Very Low	Unlikely	Negligible	Negligible	Very Low	Unlikely	Negligible
Fauna	Marine	<i>Alinyata flavidus</i>	Marine crab	NA	Not Assessed	Vulnerable	NA	Construction	Human disturbances	High	Negligible	Very Low	Unlikely	Negligible	Negligible	Very Low	Unlikely	Negligible
Fauna	Marine	<i>Alinyata integerrimus</i>	Marine crab	Red egg crab	Not Assessed	Vulnerable	NA	Construction	Human disturbances	High	Negligible	Very Low	Unlikely	Negligible	Negligible	Very Low	Unlikely	Negligible
Fauna	Marine	<i>Callinectes hospes</i>	Marine crab	NA	Not Assessed	Vulnerable	NA	Construction	Human disturbances	High	Negligible	Very Low	Unlikely	Negligible	Negligible	Very Low	Unlikely	Negligible
Fauna	Marine	<i>Callinectes philippinus</i>	Marine crab	NA	Not Assessed	Vulnerable	NA	Construction	Human disturbances	High	Negligible	Very Low	Unlikely	Negligible	Negligible	Very Low	Unlikely	Negligible
Fauna	Marine	<i>Hyas debilis</i>	Marine crab	NA	Not Assessed	Vulnerable	NA	Construction	Human disturbances	High	Negligible	Very Low	Unlikely	Negligible	Negligible	Very Low	Unlikely	Negligible
Fauna	Marine	<i>Hyas debilis</i>	Marine crab	NA	Not Assessed	Vulnerable	NA	Construction	Human disturbances	High	Negligible	Very Low	Unlikely	Negligible	Negligible	Very Low	Unlikely	Negligible
Fauna	Marine	<i>Hyas debilis</i>	Marine crab	NA	Not Assessed	Vulnerable	NA	Construction	Human disturbances	High	Negligible	Very Low	Unlikely	Negligible	Negligible	Very Low	Unlikely	Negligible
Fauna	Marine	<i>Hyas debilis</i>	Marine crab	NA	Not Assessed	Vulnerable	NA	Construction	Human disturbances	High	Negligible	Very Low	Unlikely	Negligible	Negligible	Very Low	Unlikely	Negligible
Fauna	Marine	<i>Hyas debilis</i>	Marine crab	NA	Not Assessed	Vulnerable	NA	Construction	Human disturbances	High	Negligible	Very Low	Unlikely	Negligible	Negligible	Very Low	Unlikely	Negligible
Fauna	Marine	<i>Hyas debilis</i>	Marine crab	NA	Not Assessed	Vulnerable	NA	Construction	Human disturbances	High	Negligible	Very Low	Unlikely	Negligible	Negligible	Very Low	Unlikely	Negligible
Fauna																		

Receptor Type	Type	Species	Taxon	Common name	Global status	National status	Recorded during field assessment?	Phase	Impact type	Sensitivity (S)	Impact Intensity (I)	Consequence (C = S x I)	Likelihood (L)	Impact significance	Residual impact intensity	Residual consequence	Residual likelihood	Residual impact significance
Faunal	Marine	<i>Phallum glaucum</i>	Marine gastropod	Gray bonnet	Not Assessed	Endangered	No	Construction	Human disturbances	High	Negligible	Very Low	Unlikely	Negligible	Negligible	Very Low	Unlikely	Negligible
Faunal	Marine	<i>Sulus unicus</i>	Marine gastropod	Island shield limpet	Not Assessed	Endangered	No	Construction	Human disturbances	High	Negligible	Very Low	Unlikely	Negligible	Medium	Medium	Unlikely	Negligible
Faunal	Marine	<i>Strombus viridis</i>	Marine gastropod	Black-lipped conch	Not Assessed	Vulnerable	No	Construction	Human disturbances	High	Negligible	Very Low	Unlikely	Negligible	Medium	Medium	Unlikely	Negligible
Faunal	Marine	<i>Tringa erythraea</i>	Marine gastropod	NA	Not Assessed	Endangered	No	Construction	Human disturbances	High	Negligible	Very Low	Unlikely	Negligible	Medium	Medium	Unlikely	Negligible
Faunal	Marine	<i>Trinostola oryza</i>	Marine gastropod	NA	Not Assessed	Endangered	No	Construction	Human disturbances	High	Negligible	Very Low	Unlikely	Negligible	Negligible	Very Low	Unlikely	Negligible
Faunal	Marine	<i>Trochus niloticus</i>	Marine gastropod	NA	Not Assessed	Vulnerable	No	Construction	Human disturbances	High	Negligible	Very Low	Unlikely	Negligible	Negligible	Very Low	Unlikely	Negligible
Faunal	Marine	<i>Urosalpinx sauranse</i>	Marine gastropod	NA	Not Assessed	Endangered	No	Construction	Human disturbances	High	Negligible	Very Low	Unlikely	Negligible	Medium	Medium	Unlikely	Negligible
Faunal	Marine	<i>Dugong dugon</i>	Marine mammal	Dugong	Vulnerable	Critically Endangered	No	Construction	Human disturbances	High	Negligible	Very Low	Unlikely	Negligible	Negligible	Very Low	Unlikely	Negligible
Faunal	Marine	<i>Neophocaena phocaenoides</i>	Marine mammal	Finless porpoise	Vulnerable	Critically Endangered	No	Construction	Human disturbances	High	Negligible	Very Low	Unlikely	Negligible	Negligible	Very Low	Unlikely	Negligible
Faunal	Marine	<i>Orcaella brevirostris</i>	Marine mammal	Irrawaddy dolphin	Vulnerable	Critically Endangered	No	Construction	Human disturbances	High	Negligible	Very Low	Unlikely	Negligible	Negligible	Very Low	Unlikely	Negligible
Faunal	Marine	<i>Sousa chinensis</i>	Marine mammal	Indo-pacific humpbacked dolphin	Near Threatened	Critically Endangered	No	Construction	Human disturbances	High	Negligible	Very Low	Unlikely	Negligible	Negligible	Very Low	Unlikely	Negligible
Faunal	Marine	<i>Tursiops aduncus</i>	Marine mammal	Indo-pacific bottlenose dolphin	Data Deficient	Critically Endangered	No	Construction	Human disturbances	High	Negligible	Very Low	Unlikely	Negligible	Negligible	Very Low	Unlikely	Negligible
Faunal	Marine	<i>Phocaenoides sp.</i>	Marine ribbon worm	NA	Not Assessed	Endangered	No	Construction	Human disturbances	High	Negligible	Very Low	Unlikely	Negligible	Negligible	Very Low	Unlikely	Negligible
Faunal	Marine	<i>Athanas japonicus</i>	Marine shrimp	NA	Not Assessed	Vulnerable	NA	Construction	Human disturbances	High	Negligible	Very Low	Unlikely	Negligible	Low	Low	Unlikely	Negligible
Faunal	Marine	<i>Athanas polymorphus</i>	Marine shrimp	NA	Not Assessed	Vulnerable	NA	Construction	Human disturbances	High	Negligible	Very Low	Unlikely	Negligible	Low	Low	Unlikely	Negligible
Faunal	Marine	<i>Potamiphepus jinhoni</i>	Marine shrimp	NA	Not Assessed	Vulnerable	NA	Construction	Human disturbances	High	Negligible	Very Low	Unlikely	Negligible	Low	Low	Unlikely	Negligible
Faunal	Marine	<i>Potamiphepus bozeri</i>	Marine shrimp	NA	Not Assessed	Vulnerable	NA	Construction	Human disturbances	High	Negligible	Very Low	Unlikely	Negligible	Low	Low	Unlikely	Negligible
Faunal	Marine	<i>Salmonus singaporensis</i>	Marine shrimp	NA	Not Assessed	Critically Endangered	No	Construction	Human disturbances	High	Negligible	Very Low	Unlikely	Negligible	Low	Low	Unlikely	Negligible
Faunal	Marine	<i>Apurysus sylviae</i>	Boat-dwelling sea slug	Boat-dwelling sea slug	Least Concern	Endangered	No	Construction	Human disturbances	High	Negligible	Very Low	Unlikely	Negligible	Negligible	Very Low	Unlikely	Negligible
Faunal	Marine	<i>Siphopus hermanni</i>	Sea cucumber	Hermann's sea cucumber	Vulnerable	Not Assessed	No	Construction	Human disturbances	High	Negligible	Very Low	Unlikely	Negligible	Low	Low	Unlikely	Negligible
Faunal	Marine	<i>Echinaster</i>	Sea star	NA	Not Assessed	Endangered	No	Construction	Human disturbances	High	Negligible	Very Low	Unlikely	Negligible	Low	Low	Unlikely	Negligible
Faunal	Marine	<i>Umbra musata</i>	Sea star	Light-armed sea star	Not Assessed	Endangered	No	Construction	Human disturbances	High	Negligible	Very Low	Unlikely	Negligible	Low	Low	Unlikely	Negligible
Faunal	Marine	<i>Protasterias nodosus</i>	Sea star	Knobby sea star, chocolate chip sea star	Not Assessed	Endangered	No	Construction	Human disturbances	High	Negligible	Very Low	Unlikely	Negligible	Low	Low	Unlikely	Negligible
Faunal	Marine	<i>Cyathodendrum adhaesivum</i>	Anemone	NA	Not Listed	Critically Endangered	NA	Construction	Human disturbances	High	Negligible	Very Low	Unlikely	Negligible	Low	Low	Unlikely	Negligible
Faunal	Marine	<i>Leathery anemone</i>	Anemone	Leathery anemone	Not Listed	Endangered	NA	Construction	Human disturbances	High	Negligible	Very Low	Unlikely	Negligible	Negligible	Very Low	Unlikely	Negligible
Faunal	Terrestrial	<i>Macrodactylus dorensis</i>	Anemone	Long tentacle anemone / corkcore tentacle anemone / stinky	Not Listed	Endangered	NA	Construction	Human disturbances	High	Negligible	Very Low	Unlikely	Negligible	Negligible	Very Low	Unlikely	Negligible
Faunal	Terrestrial	<i>Emballonura monticola</i>	Bat	Lesser sheath-tailed bat	Least Concern	Critically Endangered	No	Construction	Human disturbances	High	Medium	Medium	Unlikely	Negligible	Negligible	Very Low	Unlikely	Negligible
Faunal	Terrestrial	<i>Eonycteris spelaea</i>	Bat	Cave reed-tail bat	Least Concern	Vulnerable	NA	Construction	Human disturbances	High	Medium	Medium	Unlikely	Negligible	Negligible	Very Low	Unlikely	Negligible
Faunal	Terrestrial	<i>Hipposideros cinerascus</i>	Bat	Ashy roundleaf bat	Least Concern	Critically Endangered	No	Construction	Human disturbances	High	Medium	Medium	Unlikely	Negligible	Negligible	Very Low	Unlikely	Negligible
Faunal	Terrestrial	<i>Hypsignathus monstrosus</i>	Bat	Big-eared pipistrelle	Data Deficient	Critically Endangered	No	Construction	Human disturbances	High	Medium	Medium	Unlikely	Negligible	Negligible	Very Low	Unlikely	Negligible
Faunal	Terrestrial	<i>Myotis macleani</i>	Bat	Lesser long-tongued nectar bat	Least Concern	Vulnerable	NA	Construction	Human disturbances	High	Medium	Medium	Unlikely	Negligible	Negligible	Very Low	Unlikely	Negligible
Faunal	Terrestrial	<i>Myotis daubentonii</i>	Bat	Lesser false-vampire	Least Concern	Endangered	No	Construction	Human disturbances	High	Medium	Medium	Unlikely	Negligible	Negligible	Very Low	Unlikely	Negligible
Faunal	Terrestrial	<i>Pteropus variegatus</i>	Bat	Large flying-fox	Near Threatened	Critically Endangered	No	Construction	Human disturbances	High	Medium	Medium	Unlikely	Negligible	Negligible	Very Low	Unlikely	Negligible
Faunal	Terrestrial	<i>Taphozous longimanus</i>	Bat	Long-winged tomb bat	Least Concern	Critically Endangered	No	Construction	Human disturbances	High	Medium	Medium	Unlikely	Negligible	Negligible	Very Low	Unlikely	Negligible
Faunal	Terrestrial	<i>Tyonycteris malayana</i>	Bat	Greater bamboo bat	Least Concern	Vulnerable	NA	Construction	Human disturbances	High	Medium	Medium	Unlikely	Negligible	Negligible	Very Low	Unlikely	Negligible
Faunal	Terrestrial	<i>Kyabura kyabura</i>	Bird	Buffy fish owl	Least Concern	Vulnerable	NA	Construction	Human disturbances	High	High	High	Possible	Minor	Negligible	Very Low	Unlikely	Minor
Faunal	Terrestrial	<i>Anthracoceros albertus</i>	Bird	On-land pied hornbill	Least Concern	Near Threatened	Yes	Construction	Human disturbances	High	High	High	Possible	Minor	Medium	Medium	Unlikely	Minor
Faunal	Terrestrial	<i>Acridotheres tristis</i>	Bird	Crested cuckoo	Least Concern	Near Threatened	Yes	Construction	Human disturbances	High	High	High	Possible	Minor	Negligible	Very Low	Unlikely	Minor
Faunal	Terrestrial	<i>Alcedo meninting</i>	Bird	Blue-eared kingfisher	Least Concern	Endangered	No	Construction	Human disturbances	High	High	High	Possible	Minor	Negligible	Very Low	Unlikely	Minor
Faunal	Terrestrial	<i>Artibeus leucogaster</i>	Bird	Purple heron	Least Concern	Endangered	NA	Construction	Human disturbances	High	Medium	Medium	Possible	Minor	Medium	Medium	Unlikely	Minor
Faunal	Terrestrial	<i>Ceryle alcyon</i>	Bird	Spoon-billed sandpiper	Least Concern	Endangered	NA	Construction	Human disturbances	High	High	High	Possible	Minor	Negligible	Very Low	Unlikely	Minor
Faunal	Terrestrial	<i>Ceryle alcyon</i>	Bird	Spoon-billed sandpiper	Least Concern	Endangered	NA	Construction	Human disturbances	High	High	High	Possible	Minor	Negligible	Very Low	Unlikely	Minor
Faunal	Terrestrial	<i>Charadrius peronii</i>	Bird	Malaysian plover	Near Threatened	Critically Endangered	No	Construction	Human disturbances	High	High	High	Possible	Minor	Medium	Medium	Unlikely	Minor
Faunal	Terrestrial	<i>Gallinago subsp.</i>	Bird	Chinese egret	Vulnerable	Endangered	NA	Construction	Human disturbances	High	Medium	Medium	Possible	Minor	Medium	Medium	Unlikely	Minor
Faunal	Terrestrial	<i>Halcyon coromanda</i>	Bird	Ruddy kingfisher	Least Concern	Critically Endangered	No	Construction	Human disturbances	High	High	High	Possible	Minor	Negligible	Very Low	Unlikely	Minor
Faunal	Terrestrial	<i>Halastur hololeucos</i>	Bird	Gray-headed fish eagle	Near Threatened	Vulnerable	NA	Construction	Human disturbances	High	Medium	Medium	Possible	Minor	Negligible	Very Low	Unlikely	Minor
Faunal	Terrestrial	<i>Lopholophus javanicus</i>	Bird	Lesser adjutant	Vulnerable	Vulnerable	NA	Construction	Human disturbances	High	High	High	Possible	Minor	Medium	Medium	Unlikely	Minor
Faunal	Terrestrial	<i>Numenius madagascariensis</i>	Bird	Far eastern curlew	Endangered	Endangered	No	Construction	Human disturbances	High	High	High	Possible	Minor	Negligible	Very Low	Unlikely	Minor
Faunal	Terrestrial	<i>Nycticorax nycticorax</i>	Bird	Black-crowned night heron	Least Concern	Endangered	NA	Construction	Human disturbances	High	High	High	Possible	Minor	Medium	Medium	Unlikely	Minor
Faunal	Terrestrial	<i>Spilornis cheela</i>	Bird	Crested serpent eagle	Least Concern	Critically Endangered	NA	Construction	Human disturbances	High	Medium	Medium	Possible	Minor	Negligible	Very Low	Unlikely	Minor
Faunal	Terrestrial	<i>Stema sumatrana</i>	Bird	Black-naped tern	Least Concern	Endangered	NA	Construction	Human disturbances	High	High	High	Possible	Minor	Negligible	Very Low	Unlikely	Minor
Faunal	Terrestrial	<i>Stomus albifrons</i>	Bird	Little tern	Least Concern	Endangered	NA	Construction	Human disturbances	High	High	High	Possible	Minor	Negligible	Very Low	Unlikely	Minor
Faunal	Terrestrial	<i>Tinga titinga</i>	Bird	Northern's greenheron	Endangered	Endangered	NA	Construction	Human disturbances	High	High	High	Possible	Minor	Negligible	Very Low	Unlikely	Minor
Faunal	Terrestrial	<i>Actitis hypoleucos</i>	Bird	Great horned owl	Least Concern	Endangered	NA	Construction	Human disturbances	High	Medium	Medium	Possible	Minor	Medium	Medium	Unlikely	Minor
Faunal	Terrestrial	<i>Ardea sumatrana</i>	Bird	Great-billed heron	Least Concern	Critically Endangered	Yes	Construction	Human disturbances	High	Medium	Medium	Possible	Minor	Medium	Medium	Unlikely	Minor
Faunal	Terrestrial	<i>Nisus vitiensis</i>	Bird	Changsha hawk-eagle	Least Concern	Endangered	Yes	Construction	Human disturbances	High	Medium	Medium	Possible	Minor	Negligible	Very Low	Unlikely	Minor
Faunal	Terrestrial	<i>Cacomantis saundersi</i>	Bird	Bush-breasted cuckoo	Least Concern	Near Threatened	NA	Construction	Human disturbances	High	High	High	Possible	Minor	Medium	Medium	Unlikely	Minor
Faunal	Terrestrial	<i>Cnemidophorus taylori</i>	Bird	Malayian cuckoo	Least Concern	Endangered	NA	Construction	Human disturbances	High	High	High	Possible	Minor	Negligible	Very Low	Unlikely	Minor
Faunal	Terrestrial	<i>Cyornis brunneata</i>	Bird	Brown-chested jungle flycatcher	Vulnerable	Vulnerable	NA	Construction	Human disturbances	High	High	High	Possible	Minor	Negligible	Very Low	Unlikely	Minor
Faunal	Terrestrial	<i>Cyornis brunneata</i>	Bird	Brown-chested jungle flycatcher	Least Concern	Critically Endangered	NA	Construction	Human disturbances	High	High	High	Possible	Minor	Negligible	Very Low	Unlikely	Minor
Faunal	Terrestrial	<i>Galus gallus</i>	Bird	Red junglefowl	Least Concern	Near Threatened	NA	Construction	Human disturbances	High	Low	Low	Unlikely	Negligible	High	High	Unlikely	Negligible
Faunal	Terrestrial	<i>Colinus pectoratus</i>	Bird	Blue-crowned hanging parrot	Least Concern	Critically Endangered	NA	Construction	Human disturbances	High	Medium	Medium	Unlikely	Negligible	Medium	Medium	Unlikely	Negligible
Faunal	Terrestrial	<i>Pitta megarhynchos</i>	Bird	Mangrove pitta	Near Threatened	Endangered	NA	Construction	Human disturbances	High	High	High	Possible	Minor	Medium	Medium	Unlikely	Negligible
Faunal	Terrestrial	<i>Ptilinopus melanoleucus</i>	Bird	Long-billed parakeet	Vulnerable	Near Threatened	NA	Construction	Human disturbances	High	Medium	Medium	Unlikely	Negligible	Medium	Medium	Unlikely	Negligible
Faunal	Terrestrial	<i>Actinopsitta tzeuensis</i>	Bird	Red-tipped tate	Least Concern	Near Threatened	NA	Construction	Human disturbances	High	High	High	Possible	Minor	Negligible	Very Low	Unlikely	Negligible
Faunal	Terrestrial	<i>Corychopsis melanoleucus</i>	Bird	White-rumped shama	Least Concern	Endangered	Yes	Construction	Human disturbances	High	High	High	Possible	Minor	Negligible	Very Low	Unlikely	Negligible
Faunal	Terrestrial	<i>Corychopsis melanoleucus</i>	Bird	On-land magpie-rob	Least Concern	Vulnerable	Yes	Construction	Human disturbances	High	High	High	Possible	Minor	Negligible	Very Low	Unlikely	Negligible
Faunal	Terrestrial	<i>Pyrocephalus rubineus</i>	Bird	Red-whiskered bulbul	Critically Endangered	Endangered	Yes	Construction	Human disturbances	High	High	High	Possible	Minor	Negligible	Very Low	Unlikely	Negligible
Faunal	Terrestrial	<i>Arhopala amphitruta amphitruta</i>	Butterfly	NA	Not Listed	Nationally Extinct (Rediscovered)	No	Construction	Human disturbances	High	Low	Low	Unlikely	Negligible	Negligible	Very Low	Unlikely	Negligible
Faunal	Terrestrial	<i>Ariadne aristae aristae</i>	Butterfly	Angled castor	Not Listed	Nationally Extinct (Rediscovered)	No	Construction	Human disturbances	High	Low	Low	Unlikely	Negligible	Negligible	Very Low	Unlikely	Negligible
Faunal	Terrestrial	<i>Actipopterus jama jama</i>	Butterfly	Forest hopper	Not Listed	Nationally Extinct (Rediscovered)	No	Construction	Human disturbances	High	Low	Low	Unlikely	Negligible	Negligible	Very Low	Unlikely	Negligible
Faunal	Terrestrial	<i>Bubo chinensis</i>	Butterfly	Formosan swift	Not Listed	Endangered	NA	Construction	Human disturbances	High	Low	Low	Unlikely	Negligible	Negligible	Very Low	Unlikely	Negligible
Faunal	Terrestrial	<i>Callitis malaya</i>	Butterfly	Malayan swift	Not Listed	Nationally Extinct (Rediscovered)	No	Construction	Human disturbances	High	Low	Low	Unlikely	Negligible	Negligible			

Receptor Type	Type	Species	Taxon	Common name	Global status	National status	Recorded during field assessment?	Phase	Impact type	Sensitivity (S)	Impact Intensity (I)	Consequence (C = S x I)	Likelihood	Impact significance	Residual impact	Residual consequence	Residual likelihood	Residual impact significance
Fauna	Terrestrial	<i>Tetitia cactoris sticta</i>	Butterfly	Common palm dart	Not Listed	Nationally Extinct (Rediscovered)	No	Construction	Human disturbances	High	Low	Low	Unlikely	Negligible	Negligible	Very Low	Unlikely	Negligible
Fauna	Terrestrial	<i>Enas nebulosa celonius</i>	Butterfly	Common barbetina	Not Listed	Vulnerable	No	Construction	Human disturbances	High	Low	Low	Unlikely	Negligible	Negligible	Very Low	Unlikely	Negligible
Fauna	Terrestrial	<i>Euploea laticollis idonei</i>	Butterfly	dwarf crow	Not Listed	Endangered	Yes	Construction	Human disturbances	High	Low	Low	Unlikely	Negligible	Low	Low	Unlikely	Negligible
Fauna	Terrestrial	<i>Graphium doon evertonides</i>	Butterfly	Common lay	Not Listed	Not Evaluated	Yes	Construction	Human disturbances	High	Low	Low	Unlikely	Negligible	Negligible	Very Low	Unlikely	Negligible
Fauna	Terrestrial	<i>Polypus mooli mooli</i>	Butterfly	Malayan nabab	Not Listed	Nationally Extinct (Rediscovered)	Yes	Construction	Human disturbances	High	Low	Low	Unlikely	Negligible	Negligible	Very Low	Unlikely	Negligible
Fauna	Terrestrial	<i>Melipotis arthurii</i>	Damselfly	Arthur's midget	Not Listed	Vulnerable	Yes	Construction	Human disturbances	High	Low	Low	Unlikely	Negligible	Negligible	Very Low	Unlikely	Negligible
Fauna	Terrestrial	<i>Arora gombeyi</i>	Dragonfly	Low emperor	Not Listed	Least Concern	No	Construction	Human disturbances	High	Low	Low	Unlikely	Negligible	Negligible	Very Low	Unlikely	Negligible
Fauna	Terrestrial	<i>Oncorhynchus mossambicus</i>	Freshwater fish	Common / Mozambique tilapia	Vulnerable	Not Evaluated	No	Construction	Human disturbances	High	Negligible	Very Low	Unlikely	Negligible	Low	Low	Unlikely	Negligible
Fauna	Terrestrial	<i>Channa asiatica</i>	Hermit crab	Land hermit crab	Not Listed	Vulnerable	No	Construction	Human disturbances	High	Negligible	Very Low	Unlikely	Negligible	Negligible	Very Low	Unlikely	Negligible
Fauna	Terrestrial	<i>Thalassia anomala</i>	NA	Not Listed	Not Listed	Endangered	No	Construction	Human disturbances	High	Negligible	Very Low	Unlikely	Negligible	Negligible	Very Low	Unlikely	Negligible
Fauna	Terrestrial	<i>Thalassia gravata</i>	Mud lobster	NA	Not Listed	Endangered	No	Construction	Human disturbances	High	Negligible	Very Low	Unlikely	Negligible	Low	Low	Unlikely	Negligible
Fauna	Terrestrial	<i>Wentworthia thalassensis</i>	Mud shrimp	NA	Not Listed	Endangered	No	Construction	Human disturbances	High	Negligible	Very Low	Unlikely	Negligible	Low	Low	Unlikely	Negligible
Fauna	Terrestrial	<i>Aonyx cinereus</i>	Non-marine mammal	Oriental small clawed otter	Vulnerable	Critically Endangered	No	Construction	Human disturbances	High	Medium	Medium	Unlikely	Negligible	Negligible	Very Low	Unlikely	Negligible
Fauna	Terrestrial	<i>Myotis trachypus</i>	Non-marine mammal	Malayan scopsin	Least Concern	Critically Endangered	No	Construction	Human disturbances	High	High	High	Unlikely	Negligible	Negligible	Very Low	Unlikely	Negligible
Fauna	Terrestrial	<i>Manis javanica</i>	Non-marine mammal	Sunda pangolin	Critically Endangered	Critically Endangered	No	Construction	Human disturbances	High	Medium	Medium	Unlikely	Negligible	Negligible	Very Low	Unlikely	Negligible
Fauna	Terrestrial	<i>Lutrogale persaculata</i>	Non-marine mammal	smooth otter	Vulnerable	Endangered	Yes	Construction	Human disturbances	High	Medium	Medium	Unlikely	Negligible	Negligible	Very Low	Unlikely	Negligible
Fauna	Terrestrial	<i>Macaca fascicularis</i>	Non-marine mammal	long tail red macaque	Endangered	Least Concern	Yes	Construction	Human disturbances	High	Negligible	Very Low	Unlikely	Negligible	Negligible	Very Low	Unlikely	Negligible
Fauna	Terrestrial	<i>Prionailurus bengalensis</i>	Non-marine mammal	leopard cat	Least Concern	Endangered	Yes	Construction	Human disturbances	High	High	High	Unlikely	Negligible	Negligible	Very Low	Unlikely	Negligible
Fauna	Terrestrial	<i>Tragulus napu</i>	Non-marine mammal	Greater mousedeer	Least Concern	Critically Endangered	Yes	Construction	Human disturbances	High	High	High	Unlikely	Negligible	Negligible	Very Low	Unlikely	Negligible
Fauna	Terrestrial	<i>Boiga cynoides</i>	Non-marine snake	Doe-footed cat snake	Least Concern	Vulnerable	No	Construction	Human disturbances	High	Medium	Medium	Less likely	Minor	Negligible	Very Low	Unlikely	Minor
Fauna	Terrestrial	<i>Boiga melanota</i>	Non-marine snake	Gold ringed cat snake	Least Concern	Vulnerable	No	Construction	Human disturbances	High	Medium	Medium	Less likely	Minor	Negligible	Very Low	Unlikely	Minor
Fauna	Terrestrial	<i>Burmesia borbonica</i>	Non-marine snake	Banded trail	Least Concern	Least Concern	No	Construction	Human disturbances	High	Medium	Medium	Less likely	Minor	Negligible	Very Low	Unlikely	Minor
Fauna	Terrestrial	<i>Ophiophagus habronatus</i>	Non-marine snake	Keel-bellied whip snake	Least Concern	Endangered	No	Construction	Human disturbances	High	Medium	Medium	Less likely	Minor	Negligible	Very Low	Unlikely	Minor
Fauna	Terrestrial	<i>Synopsis melanocapillatus</i>	Non-marine snake	Black-headed collared snake	Least Concern	Vulnerable	No	Construction	Human disturbances	High	Medium	Medium	Less likely	Minor	Negligible	Very Low	Unlikely	Minor
Fauna	Terrestrial	<i>Thersites lineatus</i>	Non-marine snake	Black pit viper	Least Concern	Vulnerable	No	Construction	Human disturbances	High	Medium	Medium	Less likely	Minor	Negligible	Very Low	Unlikely	Minor
Fauna	Terrestrial	<i>Agkistrophis muelleri</i>	Non-marine snake	White-bellied blind snake	Least Concern	Critically Endangered	Yes	Construction	Human disturbances	High	Medium	Medium	Less likely	Minor	Negligible	Very Low	Unlikely	Minor
Fauna	Terrestrial	<i>Caretta amboinensis</i>	Non-marine turtle	Malayan box terrapin	Endangered	Near Threatened	No	Construction	Human disturbances	High	Low	Low	Unlikely	Negligible	Negligible	Very Low	Unlikely	Negligible
Fauna	Marine	<i>Caenopsis</i>	Freshwater gastropod	NA	Least Concern	Vulnerable	No	Construction	Human-wildlife conflict	High	Negligible	Very Low	Unlikely	Negligible	Low	Low	Unlikely	Negligible
Fauna	Marine	<i>Conidaria</i>	NA	Not Assessed	Not Assessed	Not Assessed	No	Construction	Human-wildlife conflict	High	Negligible	Very Low	Unlikely	Negligible	Negligible	Very Low	Unlikely	Negligible
Fauna	Marine	<i>Hydrobia ulvae</i>	NA	Data Deficient	Endangered	NA	Yes	Construction	Human-wildlife conflict	High	Negligible	Very Low	Unlikely	Negligible	Negligible	Very Low	Unlikely	Negligible
Fauna	Marine	<i>Caricocarpus rotundicollis</i>	NA	Data Deficient	Vulnerable	Yes	Yes	Construction	Human-wildlife conflict	High	Negligible	Very Low	Unlikely	Negligible	Negligible	Very Low	Unlikely	Negligible
Fauna	Marine	<i>Pinna bicolor</i>	NA	Data Deficient	Not Assessed	Not Assessed	No	Construction	Human-wildlife conflict	High	Negligible	Very Low	Unlikely	Negligible	Negligible	Very Low	Unlikely	Negligible
Fauna	Marine	<i>Pinna incana</i>	NA	Critically Endangered	Not Assessed	Not Assessed	No	Construction	Human-wildlife conflict	High	Negligible	Very Low	Unlikely	Negligible	Low	Low	Unlikely	Negligible
Fauna	Marine	<i>Pinna squamosa</i>	NA	Not Assessed	CITES protected (Appendix II)	Endangered	No	Construction	Human-wildlife conflict	High	Negligible	Very Low	Unlikely	Negligible	Low	Low	Unlikely	Negligible
Fauna	Marine	<i>Alcyonaria</i>	NA	Not Assessed	Not Assessed	Not Assessed	No	Construction	Human-wildlife conflict	High	Negligible	Very Low	Unlikely	Negligible	Negligible	Very Low	Unlikely	Negligible
Fauna	Marine	<i>Alcyonaria</i>	NA	Not Assessed	Vulnerable	No	Yes	Construction	Human-wildlife conflict	High	Negligible	Very Low	Unlikely	Negligible	Negligible	Very Low	Unlikely	Negligible
Fauna	Marine	<i>Alcyonaria</i>	NA	Not Assessed	Vulnerable	NA	Yes	Construction	Human-wildlife conflict	High	Negligible	Very Low	Unlikely	Negligible	Negligible	Very Low	Unlikely	Negligible
Fauna	Marine	<i>Alcyonaria</i>	NA	Not Assessed	Vulnerable	NA	Yes	Construction	Human-wildlife conflict	High	Negligible	Very Low	Unlikely	Negligible	Negligible	Very Low	Unlikely	Negligible
Fauna	Marine	<i>Alcyonaria</i>	NA	Not Assessed	Vulnerable	NA	Yes	Construction	Human-wildlife conflict	High	Negligible	Very Low	Unlikely	Negligible	Negligible	Very Low	Unlikely	Negligible
Fauna	Marine	<i>Alcyonaria</i>	NA	Not Assessed	Vulnerable	NA	Yes	Construction	Human-wildlife conflict	High	Negligible	Very Low	Unlikely	Negligible	Negligible	Very Low	Unlikely	Negligible
Fauna	Marine	<i>Alcyonaria</i>	NA	Not Assessed	Vulnerable	NA	Yes	Construction	Human-wildlife conflict	High	Negligible	Very Low	Unlikely	Negligible	Negligible	Very Low	Unlikely	Negligible
Fauna	Marine	<i>Alcyonaria</i>	NA	Not Assessed	Vulnerable	NA	Yes	Construction	Human-wildlife conflict	High	Negligible	Very Low	Unlikely	Negligible	Negligible	Very Low	Unlikely	Negligible
Fauna	Marine	<i>Alcyonaria</i>	NA	Not Assessed	Vulnerable	NA	Yes	Construction	Human-wildlife conflict	High	Negligible	Very Low	Unlikely	Negligible	Negligible	Very Low	Unlikely	Negligible
Fauna	Marine	<i>Alcyonaria</i>	NA	Not Assessed	Vulnerable	NA	Yes	Construction	Human-wildlife conflict	High	Negligible	Very Low	Unlikely	Negligible	Negligible	Very Low	Unlikely	Negligible
Fauna	Marine	<i>Alcyonaria</i>	NA	Not Assessed	Vulnerable	NA	Yes	Construction	Human-wildlife conflict	High	Negligible	Very Low	Unlikely	Negligible	Negligible	Very Low	Unlikely	Negligible
Fauna	Marine	<i>Alcyonaria</i>	NA	Not Assessed	Vulnerable	NA	Yes	Construction	Human-wildlife conflict	High	Negligible	Very Low	Unlikely	Negligible	Negligible	Very Low	Unlikely	Negligible
Fauna	Marine	<i>Alcyonaria</i>	NA	Not Assessed	Vulnerable	NA	Yes	Construction	Human-wildlife conflict	High	Negligible	Very Low	Unlikely	Negligible	Negligible	Very Low	Unlikely	Negligible
Fauna	Marine	<i>Alcyonaria</i>	NA	Not Assessed	Vulnerable	NA	Yes	Construction	Human-wildlife conflict	High	Negligible	Very Low	Unlikely	Negligible	Negligible	Very Low	Unlikely	Negligible
Fauna	Marine	<i>Alcyonaria</i>	NA	Not Assessed	Vulnerable	NA	Yes	Construction	Human-wildlife conflict	High	Negligible	Very Low	Unlikely	Negligible	Negligible	Very Low	Unlikely	Negligible
Fauna	Marine	<i>Alcyonaria</i>	NA	Not Assessed	Vulnerable	NA	Yes	Construction	Human-wildlife conflict	High	Negligible	Very Low	Unlikely	Negligible	Negligible	Very Low	Unlikely	Negligible
Fauna	Marine	<i>Alcyonaria</i>	NA	Not Assessed	Vulnerable	NA	Yes	Construction	Human-wildlife conflict	High	Negligible	Very Low	Unlikely	Negligible	Negligible	Very Low	Unlikely	Negligible
Fauna	Marine	<i>Alcyonaria</i>	NA	Not Assessed	Vulnerable	NA	Yes	Construction	Human-wildlife conflict	High	Negligible	Very Low	Unlikely	Negligible	Negligible	Very Low	Unlikely	Negligible
Fauna	Marine	<i>Alcyonaria</i>	NA	Not Assessed	Vulnerable	NA	Yes	Construction	Human-wildlife conflict	High	Negligible	Very Low	Unlikely	Negligible	Negligible	Very Low	Unlikely	Negligible
Fauna	Marine	<i>Alcyonaria</i>	NA	Not Assessed	Vulnerable	NA	Yes	Construction	Human-wildlife conflict	High	Negligible	Very Low	Unlikely	Negligible	Negligible	Very Low	Unlikely	Negligible
Fauna	Marine	<i>Alcyonaria</i>	NA	Not Assessed	Vulnerable	NA	Yes	Construction	Human-wildlife conflict	High	Negligible	Very Low	Unlikely	Negligible	Negligible	Very Low	Unlikely	Negligible
Fauna	Marine	<i>Alcyonaria</i>	NA	Not Assessed	Vulnerable	NA	Yes	Construction	Human-wildlife conflict	High	Negligible	Very Low	Unlikely	Negligible	Negligible	Very Low	Unlikely	Negligible
Fauna	Marine	<i>Alcyonaria</i>	NA	Not Assessed	Vulnerable	NA	Yes	Construction	Human-wildlife conflict	High	Negligible	Very Low	Unlikely	Negligible	Negligible	Very Low	Unlikely	Negligible
Fauna	Marine	<i>Alcyonaria</i>	NA	Not Assessed	Vulnerable	NA	Yes	Construction	Human-wildlife conflict	High	Negligible	Very Low	Unlikely	Negligible	Negligible	Very Low	Unlikely	Negligible
Fauna	Marine	<i>Alcyonaria</i>	NA	Not Assessed	Vulnerable	NA	Yes	Construction	Human-wildlife conflict	High	Negligible	Very Low	Unlikely	Negligible	Negligible	Very Low	Unlikely	Negligible
Fauna	Marine	<i>Alcyonaria</i>	NA	Not Assessed	Vulnerable	NA	Yes	Construction	Human-wildlife conflict	High	Negligible	Very Low	Unlikely	Negligible	Negligible	Very Low	Unlikely	Negligible
Fauna	Marine	<i>Alcyonaria</i>	NA	Not Assessed	Vulnerable	NA	Yes	Construction	Human-wildlife conflict	High	Negligible	Very Low	Unlikely	Negligible	Negligible	Very Low	Unlikely	Negligible
Fauna	Marine	<i>Alcyonaria</i>	NA	Not Assessed	Vulnerable	NA	Yes	Construction	Human-wildlife conflict	High	Negligible	Very Low	Unlikely	Negligible	Negligible	Very Low	Unlikely	Negligible
Fauna	Marine	<i>Alcyonaria</i>	NA	Not Assessed	Vulnerable	NA	Yes	Construction	Human-wildlife conflict	High	Negligible	Very Low	Unlikely	Negligible	Negligible	Very Low	Unlikely	Negligible
Fauna	Marine	<i>Alcyonaria</i>	NA	Not Assessed	Vulnerable	NA	Yes	Construction	Human-wildlife conflict	High	Negligible	Very Low	Unlikely	Negligible	Negligible	Very Low	Unlikely	Negligible
Fauna	Marine	<i>Alcyonaria</i>	NA	Not Assessed	Vulnerable	NA	Yes	Construction	Human-wildlife conflict	High	Negligible	Very Low	Unlikely	Negligible	Negligible	Very Low	Unlikely	Negligible
Fauna	Marine	<i>Alcyonaria</i>	NA	Not Assessed	Vulnerable	NA	Yes	Construction	Human-wildlife conflict	High	Negligible	Very Low	Unlikely	Negligible	Negligible	Very Low	Unlikely	Negligible
Fauna	Marine	<i>Alcyonaria</i>	NA	Not Assessed	Vulnerable	NA	Yes	Construction	Human-wildlife conflict	High	Negligible	Very Low	Unlikely	Negligible	Negligible	Very Low	Unlikely	Negligible
Fauna	Marine	<i>Alcyonaria</i>	NA	Not Assessed	Vulnerable	NA	Yes	Construction	Human-wildlife conflict	High	Negligible	Very Low	Unlikely	Negligible	Negligible	Very Low	Unlikely	Negligible
Fauna	Marine	<i>Alcyonaria</i>	NA	Not Assessed	Vulnerable	NA	Yes	Construction	Human-wildlife conflict	High	Negligible	Very Low	Unlikely	Negligible	Negligible	Very Low	Unlikely	Negligible
Fauna	Marine	<i>Alcyonaria</i>	NA	Not Assessed	Vulnerable	NA	Yes	Construction	Human-wildlife conflict	High	Negligible	Very Low	Unlikely	Negligible	Negligible	Very Low	Unlikely	Negligible
Fauna	Marine	<i>Alcyonaria</i>	NA	Not Assessed	Vulnerable	NA	Yes	Construction	Human-wildlife conflict	High	Negligible	Very Low	Unlikely	Negligible	Negligible	Very Low	Unlikely	Negligible
Fauna	Marine	<i>Alcyonaria</i>	NA	Not Assessed	Vulnerable	NA	Yes	Construction	Human-wildlife conflict	High	Negligible	Very Low	Unlikely	Negligible	Negligible	Very Low	Unlikely	Negligible
Fauna	Marine																	

Receptor Type	Type	Species	Taxon	Common name	Global status	National status	Recorded during field assessment?	Phase	Impact type	Sensitivity (S)	Impact Intensity (I)	Consequence (C = S x I)	Likelihood	Impact significance (C x I)	Residual impact intensity	Residual consequence	Residual likelihood	Residual impact significance
Faunal	Terrestrial	<i>Taphozous longimanus</i>	Bat	Long-winged tomb bat	Least Concern	Critically Endangered	No	Construction	Human-wildlife conflict	High	Low	Low	Unlikely	Negligible	High	High	Unlikely	Negligible
Faunal	Terrestrial	<i>Tyloderes malayana</i>	Bird	Greater bamboo bat	Least Concern	Vulnerable	No	Construction	Human-wildlife conflict	High	Low	Low	Unlikely	Negligible	High	Low	Unlikely	Negligible
Faunal	Terrestrial	<i>Acridotheres tristis</i>	Bird	Crested ash hawk	Least Concern	Near Threatened	No	Construction	Human-wildlife conflict	High	Negligible	Very Low	Unlikely	Negligible	Negligible	Very Low	Unlikely	Negligible
Faunal	Terrestrial	<i>Alcedo meninting</i>	Bird	Blue-eared kingfisher	Least Concern	Endangered	No	Construction	Human-wildlife conflict	High	Negligible	Very Low	Unlikely	Negligible	Negligible	Very Low	Unlikely	Negligible
Faunal	Terrestrial	<i>Actus purpurata</i>	Bird	Purple heron	Least Concern	Endangered	No	Construction	Human-wildlife conflict	High	Negligible	Very Low	Unlikely	Negligible	Negligible	Very Low	Unlikely	Negligible
Faunal	Terrestrial	<i>Actinopus squarrosus</i>	Bird	Buffy-breasted cuckoo	Least Concern	Near Threatened	No	Construction	Human-wildlife conflict	High	Negligible	Very Low	Unlikely	Negligible	Negligible	Very Low	Unlikely	Negligible
Faunal	Terrestrial	<i>Actitis hypoleucos</i>	Bird	Spoon-billed sandpiper	Critically Endangered	Critically Endangered	No	Construction	Human-wildlife conflict	High	Negligible	Very Low	Unlikely	Negligible	Negligible	Very Low	Unlikely	Negligible
Faunal	Terrestrial	<i>Actitis hypoleucos</i>	Bird	Groin knot	Endangered	Endangered	No	Construction	Human-wildlife conflict	High	Negligible	Very Low	Unlikely	Negligible	Negligible	Very Low	Unlikely	Negligible
Faunal	Terrestrial	<i>Actitis hypoleucos</i>	Bird	Malaysian prong	Near Threatened	Critically Endangered	No	Construction	Human-wildlife conflict	High	Negligible	Very Low	Unlikely	Negligible	Negligible	Very Low	Unlikely	Negligible
Faunal	Terrestrial	<i>Actinopus squarrosus</i>	Bird	Wrist cuckoo	Least Concern	Vulnerable	No	Construction	Human-wildlife conflict	High	Negligible	Very Low	Unlikely	Negligible	Negligible	Very Low	Unlikely	Negligible
Faunal	Terrestrial	<i>Actinopus squarrosus</i>	Bird	Brown-chested pug-nose flycatcher	Vulnerable	Vulnerable	No	Construction	Human-wildlife conflict	High	Negligible	Very Low	Unlikely	Negligible	Negligible	Very Low	Unlikely	Negligible
Faunal	Terrestrial	<i>Actinopus squarrosus</i>	Bird	Mangrove blue flycatcher	Least Concern	Critically Endangered	No	Construction	Human-wildlife conflict	High	Negligible	Very Low	Unlikely	Negligible	Negligible	Very Low	Unlikely	Negligible
Faunal	Terrestrial	<i>Actinopus squarrosus</i>	Bird	Chinese egret	Vulnerable	Endangered	No	Construction	Human-wildlife conflict	High	Negligible	Very Low	Unlikely	Negligible	Negligible	Very Low	Unlikely	Negligible
Faunal	Terrestrial	<i>Actinopus squarrosus</i>	Bird	Red junglefowl	Least Concern	Near Threatened	No	Construction	Human-wildlife conflict	High	Negligible	Very Low	Unlikely	Negligible	Negligible	Very Low	Unlikely	Negligible
Faunal	Terrestrial	<i>Actinopus squarrosus</i>	Bird	Ruddy kingfisher	Least Concern	Critically Endangered	No	Construction	Human-wildlife conflict	High	Negligible	Very Low	Unlikely	Negligible	Negligible	Very Low	Unlikely	Negligible
Faunal	Terrestrial	<i>Actinopus squarrosus</i>	Bird	Grey-headed fish eagle	Near Threatened	Vulnerable	No	Construction	Human-wildlife conflict	High	Negligible	Very Low	Unlikely	Negligible	Negligible	Very Low	Unlikely	Negligible
Faunal	Terrestrial	<i>Actinopus squarrosus</i>	Bird	Buffy fish owl	Least Concern	Vulnerable	No	Construction	Human-wildlife conflict	High	Negligible	Very Low	Unlikely	Negligible	Negligible	Very Low	Unlikely	Negligible
Faunal	Terrestrial	<i>Actinopus squarrosus</i>	Bird	Lesser adjutant	Vulnerable	Vulnerable	No	Construction	Human-wildlife conflict	High	Negligible	Very Low	Unlikely	Negligible	Negligible	Very Low	Unlikely	Negligible
Faunal	Terrestrial	<i>Actinopus squarrosus</i>	Bird	Blue-crowned hanging parrot	Least Concern	Least Concern	No	Construction	Human-wildlife conflict	High	Negligible	Very Low	Unlikely	Negligible	Negligible	Very Low	Unlikely	Negligible
Faunal	Terrestrial	<i>Actinopus squarrosus</i>	Bird	Far eastern curlew	Endangered	Endangered	No	Construction	Human-wildlife conflict	High	Negligible	Very Low	Unlikely	Negligible	Negligible	Very Low	Unlikely	Negligible
Faunal	Terrestrial	<i>Actinopus squarrosus</i>	Bird	Black-crowned night heron	Least Concern	Least Concern	No	Construction	Human-wildlife conflict	High	Negligible	Very Low	Unlikely	Negligible	Negligible	Very Low	Unlikely	Negligible
Faunal	Terrestrial	<i>Actinopus squarrosus</i>	Bird	Mangrove pitta	Near Threatened	Critically Endangered	No	Construction	Human-wildlife conflict	High	Negligible	Very Low	Unlikely	Negligible	Negligible	Very Low	Unlikely	Negligible
Faunal	Terrestrial	<i>Actinopus squarrosus</i>	Bird	Long-tailed parakeet	Vulnerable	Near Threatened	No	Construction	Human-wildlife conflict	High	Negligible	Very Low	Unlikely	Negligible	Negligible	Very Low	Unlikely	Negligible
Faunal	Terrestrial	<i>Actinopus squarrosus</i>	Bird	Red-legged crane	Least Concern	Near Threatened	No	Construction	Human-wildlife conflict	High	Negligible	Very Low	Unlikely	Negligible	Negligible	Very Low	Unlikely	Negligible
Faunal	Terrestrial	<i>Actinopus squarrosus</i>	Bird	Crested serpent eagle	Least Concern	Critically Endangered	No	Construction	Human-wildlife conflict	High	Negligible	Very Low	Unlikely	Negligible	Negligible	Very Low	Unlikely	Negligible
Faunal	Terrestrial	<i>Actinopus squarrosus</i>	Bird	Black-naped tern	Least Concern	Endangered	No	Construction	Human-wildlife conflict	High	Negligible	Very Low	Unlikely	Negligible	Negligible	Very Low	Unlikely	Negligible
Faunal	Terrestrial	<i>Actinopus squarrosus</i>	Bird	Little tern	Least Concern	Endangered	No	Construction	Human-wildlife conflict	High	Negligible	Very Low	Unlikely	Negligible	Negligible	Very Low	Unlikely	Negligible
Faunal	Terrestrial	<i>Actinopus squarrosus</i>	Bird	Northern green heron	Endangered	Endangered	No	Construction	Human-wildlife conflict	High	Negligible	Very Low	Unlikely	Negligible	Negligible	Very Low	Unlikely	Negligible
Faunal	Terrestrial	<i>Actinopus squarrosus</i>	Bird	Oriental pied hornbill	Least Concern	Near Threatened	Yes	Construction	Human-wildlife conflict	High	Negligible	Very Low	Unlikely	Negligible	Negligible	Very Low	Unlikely	Negligible
Faunal	Terrestrial	<i>Actinopus squarrosus</i>	Bird	Great horned owl	Least Concern	Least Concern	Yes	Construction	Human-wildlife conflict	High	Negligible	Very Low	Unlikely	Negligible	Negligible	Very Low	Unlikely	Negligible
Faunal	Terrestrial	<i>Actinopus squarrosus</i>	Bird	Great egret	Least Concern	Critically Endangered	Yes	Construction	Human-wildlife conflict	High	Negligible	Very Low	Unlikely	Negligible	Negligible	Very Low	Unlikely	Negligible
Faunal	Terrestrial	<i>Actinopus squarrosus</i>	Bird	White-rumped shama	Least Concern	Endangered	Yes	Construction	Human-wildlife conflict	High	Negligible	Very Low	Unlikely	Negligible	Negligible	Very Low	Unlikely	Negligible
Faunal	Terrestrial	<i>Actinopus squarrosus</i>	Bird	Oriental magpie robin	Least Concern	Vulnerable	Yes	Construction	Human-wildlife conflict	High	Negligible	Very Low	Unlikely	Negligible	Negligible	Very Low	Unlikely	Negligible
Faunal	Terrestrial	<i>Actinopus squarrosus</i>	Bird	Changsha brown eagle	Least Concern	Vulnerable	Yes	Construction	Human-wildlife conflict	High	Negligible	Very Low	Unlikely	Negligible	Negligible	Very Low	Unlikely	Negligible
Faunal	Terrestrial	<i>Actinopus squarrosus</i>	Bird	Sp. hooded night heron	Critically Endangered	Critically Endangered	Yes	Construction	Human-wildlife conflict	High	Negligible	Very Low	Unlikely	Negligible	Negligible	Very Low	Unlikely	Negligible
Faunal	Terrestrial	<i>Actinopus squarrosus</i>	Butterfly	NA	Not Listed	Nationally Extinct (Rediscovered)	No	Construction	Human-wildlife conflict	High	Negligible	Very Low	Unlikely	Negligible	Low	Low	Unlikely	Negligible
Faunal	Terrestrial	<i>Ariadne ariadne ariadne</i>	Butterfly	Angled castor	Not Listed	Nationally Extinct (Rediscovered)	No	Construction	Human-wildlife conflict	High	Negligible	Very Low	Unlikely	Negligible	Negligible	Very Low	Unlikely	Negligible
Faunal	Terrestrial	<i>Aspilopteryx jama jama</i>	Butterfly	Forest hopper	Not Listed	Nationally Extinct (Rediscovered)	No	Construction	Human-wildlife conflict	High	Negligible	Very Low	Unlikely	Negligible	Negligible	Very Low	Unlikely	Negligible
Faunal	Terrestrial	<i>Aspilopteryx jama jama</i>	Butterfly	Forest swift	Not Listed	Endangered	No	Construction	Human-wildlife conflict	High	Negligible	Very Low	Unlikely	Negligible	Negligible	Very Low	Unlikely	Negligible
Faunal	Terrestrial	<i>Aspilopteryx jama jama</i>	Butterfly	Malayan swift	Not Listed	Nationally Extinct (Rediscovered)	No	Construction	Human-wildlife conflict	High	Negligible	Very Low	Unlikely	Negligible	Negligible	Very Low	Unlikely	Negligible
Faunal	Terrestrial	<i>Aspilopteryx jama jama</i>	Butterfly	Acraea blue	Not Listed	Vulnerable	No	Construction	Human-wildlife conflict	High	Negligible	Very Low	Unlikely	Negligible	Low	Low	Unlikely	Negligible
Faunal	Terrestrial	<i>Aspilopteryx jama jama</i>	Butterfly	White-banded flat	Not Listed	Nationally Extinct (Rediscovered)	No	Construction	Human-wildlife conflict	High	Negligible	Very Low	Unlikely	Negligible	Negligible	Very Low	Unlikely	Negligible
Faunal	Terrestrial	<i>Aspilopteryx jama jama</i>	Butterfly	Plain palm dart	Not Listed	Nationally Extinct (Rediscovered)	No	Construction	Human-wildlife conflict	High	Negligible	Very Low	Unlikely	Negligible	Low	Low	Unlikely	Negligible
Faunal	Terrestrial	<i>Aspilopteryx jama jama</i>	Butterfly	Plain lacewing	Not Listed	Critically Endangered	No	Construction	Human-wildlife conflict	High	Negligible	Very Low	Unlikely	Negligible	Negligible	Very Low	Unlikely	Negligible
Faunal	Terrestrial	<i>Aspilopteryx jama jama</i>	Butterfly	Common duffer	Not Listed	Critically Endangered	No	Construction	Human-wildlife conflict	High	Negligible	Very Low	Unlikely	Negligible	Negligible	Very Low	Unlikely	Negligible
Faunal	Terrestrial	<i>Aspilopteryx jama jama</i>	Butterfly	Mangrove tree nymph	Not Listed	Critically Endangered	No	Construction	Human-wildlife conflict	High	Negligible	Very Low	Unlikely	Negligible	Low	Low	Unlikely	Negligible
Faunal	Terrestrial	<i>Aspilopteryx jama jama</i>	Butterfly	Melipotis caerulea	Not Listed	Nationally Extinct (Rediscovered)	No	Construction	Human-wildlife conflict	High	Negligible	Very Low	Unlikely	Negligible	Low	Low	Unlikely	Negligible
Faunal	Terrestrial	<i>Aspilopteryx jama jama</i>	Butterfly	Transparent skinned blue	Not Listed	Nationally Extinct (Rediscovered)	No	Construction	Human-wildlife conflict	High	Negligible	Very Low	Unlikely	Negligible	Low	Low	Unlikely	Negligible
Faunal	Terrestrial	<i>Aspilopteryx jama jama</i>	Butterfly	Large four-line blue	Not Listed	Nationally Extinct (Rediscovered)	No	Construction	Human-wildlife conflict	High	Negligible	Very Low	Unlikely	Negligible	Negligible	Very Low	Unlikely	Negligible
Faunal	Terrestrial	<i>Aspilopteryx jama jama</i>	Butterfly	Common rose	Not Listed	Vulnerable	No	Construction	Human-wildlife conflict	High	Negligible	Very Low	Unlikely	Negligible	Negligible	Very Low	Unlikely	Negligible
Faunal	Terrestrial	<i>Aspilopteryx jama jama</i>	Butterfly	Yellow glassy tiger	Not Listed	Nationally Extinct (Rediscovered)	No	Construction	Human-wildlife conflict	High	Negligible	Very Low	Unlikely	Negligible	Low	Low	Unlikely	Negligible
Faunal	Terrestrial	<i>Aspilopteryx jama jama</i>	Butterfly	Wanderer	Not Listed	Nationally Extinct (Rediscovered)	No	Construction	Human-wildlife conflict	High	Negligible	Very Low	Unlikely	Negligible	Negligible	Very Low	Unlikely	Negligible
Faunal	Terrestrial	<i>Aspilopteryx jama jama</i>	Butterfly	Bengal spina	Not Listed	Endangered	No	Construction	Human-wildlife conflict	High	Negligible	Very Low	Unlikely	Negligible	Low	Low	Unlikely	Negligible
Faunal	Terrestrial	<i>Aspilopteryx jama jama</i>	Butterfly	Detached dart	Not Listed	Nationally Extinct (Rediscovered)	No	Construction	Human-wildlife conflict	High	Negligible	Very Low	Unlikely	Negligible	Low	Low	Unlikely	Negligible
Faunal	Terrestrial	<i>Aspilopteryx jama jama</i>	Butterfly	Banded royal	Not Listed	Critically Endangered	No	Construction	Human-wildlife conflict	High	Negligible	Very Low	Unlikely	Negligible	Negligible	Very Low	Unlikely	Negligible
Faunal	Terrestrial	<i>Aspilopteryx jama jama</i>	Butterfly	White palm dart	Not Listed	Endangered	No	Construction	Human-wildlife conflict	High	Negligible	Very Low	Unlikely	Negligible	Low	Low	Unlikely	Negligible
Faunal	Terrestrial	<i>Aspilopteryx jama jama</i>	Butterfly	Common palm dart	Not Listed	Nationally Extinct (Rediscovered)	No	Construction	Human-wildlife conflict	High	Negligible	Very Low	Unlikely	Negligible	Low	Low	Unlikely	Negligible
Faunal	Terrestrial	<i>Aspilopteryx jama jama</i>	Butterfly	Common birdwing	Not Listed	Vulnerable	No	Construction	Human-wildlife conflict	High	Negligible	Very Low	Unlikely	Negligible	Negligible	Very Low	Unlikely	Negligible
Faunal	Terrestrial	<i>Aspilopteryx jama jama</i>	Butterfly	Dwarf cow	Not Listed	Endangered	Yes	Construction	Human-wildlife conflict	High	Negligible	Very Low	Unlikely	Negligible	Negligible	Very Low	Unlikely	Negligible
Faunal	Terrestrial	<i>Aspilopteryx jama jama</i>	Butterfly	Common Jay	Not Listed	Not Evaluated	Yes	Construction	Human-wildlife conflict	High	Negligible	Very Low	Unlikely	Negligible	Negligible	Very Low	Unlikely	Negligible
Faunal	Terrestrial	<i>Aspilopteryx jama jama</i>	Butterfly	Malayan nabea	Not Listed	Nationally Extinct (Rediscovered)	Yes	Construction	Human-wildlife conflict	High	Negligible	Very Low	Unlikely	Negligible	Low	Low	Unlikely	Negligible
Faunal	Terrestrial	<i>Aspilopteryx jama jama</i>	Butterfly	Arthur's midgit	Near Threatened	Vulnerable	Yes	Construction	Human-wildlife conflict	High	Negligible	Very Low	Unlikely	Negligible	Negligible	Very Low	Unlikely	Negligible
Faunal	Terrestrial	<i>Aspilopteryx jama jama</i>	Butterfly	Kr. cow emperor	Least Concern	Least Concern	No	Construction	Human-wildlife conflict	High	Negligible	Very Low	Unlikely	Negligible	Negligible	Very Low	Unlikely	Negligible
Faunal	Terrestrial	<i>Aspilopteryx jama jama</i>	Butterfly	Common / Nourmbugha / Slaga	Vulnerable	Not Evaluated	No	Construction	Human-wildlife conflict	High	Negligible	Very Low	Unlikely	Negligible	Negligible	Very Low	Unlikely	Negligible
Faunal	Terrestrial	<i>Aspilopteryx jama jama</i>	Butterfly	Hemil crab	Not Listed	Vulnerable	No	Construction	Human-wildlife conflict	High	Negligible	Very Low	Unlikely	Negligible	Negligible	Very Low	Unlikely	Negligible
Faunal	Terrestrial	<i>Aspilopteryx jama jama</i>	Butterfly	Mud lobster	Not Listed	Endangered	No	Construction	Human-wildlife conflict	High	Negligible	Very Low	Unlikely	Negligible	Negligible	Very Low	Unlikely	Negligible
Faunal	Terrestrial	<i>Aspilopteryx jama jama</i>	Butterfly	Mud lobster	Not Listed	Endangered	No	Construction	Human-wildlife conflict	High	Negligible	Very Low	Unlikely	Negligible	Negligible	Very Low	Unlikely	Negligible
Faunal	Terrestrial	<i>Aspilopteryx jama jama</i>	Butterfly	Mud shrimp	Not Listed	Endangered	No	Construction	Human-wildlife conflict	High	Negligible	Very Low	Unlikely	Negligible	Negligible	Very Low	Unlikely	Negligible
Faunal	Terrestrial	<i>Aspilopteryx jama jama</i>	Non-marine mammal	Ortental small clawed otter	Vulnerable	Endangered	No	Construction	Human-wildlife conflict	High	Medium	Medium	Possible	Minor	Low	Low	Unlikely	Minor
Faunal	Terrestrial	<i>Aspilopteryx jama jama</i>	Non-marine mammal	Smooth otter	Vulnerable													

Receptor Type	Type	Species	Taxon	Common name	Global status	National status	Recorded during field assessment?	Phase	Impact type	Sensitivity (S)	Impact Intensity (I)	Consequence (C = S x I)	Likelihood	Impact significance (C x L)	Residual impact intensity	Residual consequence	Residual likelihood	Residual impact significance
Faunal	Marine	<i>Perna perna</i>	Marine bivalve	Pan mussel	Critically Endangered	Not Assessed	No	Construction	Loss/reduction of ecological connectivity for faunal movement	High	High	High	Unlikely	Negligible	High	High	Unlikely	Negligible
Faunal	Marine	<i>Tridacna squamosa</i>	Marine bivalve	Tufted giant clam	Not Assessed, CITES protected (Appendix II)	Endangered	No	Construction	Loss/reduction of ecological connectivity for faunal movement	High	High	High	Unlikely	Negligible	High	High	Unlikely	Negligible
Faunal	Marine	<i>Altegatis floridus</i>	Marine crab	NA	Not Assessed	Vulnerable	No	Construction	Loss/reduction of ecological connectivity for faunal movement	High	High	High	Unlikely	Negligible	High	High	Unlikely	Negligible
Faunal	Marine	<i>Altegatis integrimus</i>	Marine crab	Red egg crab	Not Assessed	Vulnerable	No	Construction	Loss/reduction of ecological connectivity for faunal movement	High	High	High	Unlikely	Negligible	High	High	Unlikely	Negligible
Faunal	Marine	<i>Callinectes hepatica</i>	Marine crab	NA	Not Assessed	Vulnerable	No	Construction	Loss/reduction of ecological connectivity for faunal movement	High	High	High	Unlikely	Negligible	High	High	Unlikely	Negligible
Faunal	Marine	<i>Callinectes philargius</i>	Marine crab	NA	Not Assessed	Vulnerable	No	Construction	Loss/reduction of ecological connectivity for faunal movement	High	High	High	Unlikely	Negligible	High	High	Unlikely	Negligible
Faunal	Marine	<i>Lyssacis detmanii</i>	Marine crab	NA	Not Assessed	Vulnerable	No	Construction	Loss/reduction of ecological connectivity for faunal movement	High	High	High	Unlikely	Negligible	High	High	Unlikely	Negligible
Faunal	Marine	<i>Lophozozymus pictor</i>	Marine crab	Mosaic crab	Not Assessed	Endangered	No	Construction	Loss/reduction of ecological connectivity for faunal movement	High	High	High	Unlikely	Negligible	High	High	Unlikely	Negligible
Faunal	Marine	<i>Platydora granulosa</i>	Marine crab	NA	Not Assessed	Endangered	No	Construction	Loss/reduction of ecological connectivity for faunal movement	High	High	High	Unlikely	Negligible	High	High	Unlikely	Negligible
Faunal	Marine	<i>Rhinolambrus pelagicus</i>	Marine crab	Common elbow crab	Not Assessed	Vulnerable	No	Construction	Loss/reduction of ecological connectivity for faunal movement	High	High	High	Unlikely	Negligible	High	High	Unlikely	Negligible
Faunal	Marine	<i>Semaitum germaini</i>	Marine crab	NA	Not Assessed	Endangered	No	Construction	Loss/reduction of ecological connectivity for faunal movement	High	High	High	Unlikely	Negligible	High	High	Unlikely	Negligible
Faunal	Marine	<i>Uca rosea</i>	Marine crab	Rosy fiddler crab	Not Assessed	Endangered	No	Construction	Loss/reduction of ecological connectivity for faunal movement	High	High	High	Unlikely	Negligible	High	High	Unlikely	Negligible
Faunal	Marine	<i>Amphiprion clarkii</i>	Marine fish	Clark's anemonefish	Not Assessed	Vulnerable	No	Construction	Loss/reduction of ecological connectivity for faunal movement	High	High	High	Unlikely	Negligible	High	High	Unlikely	Negligible
Faunal	Marine	<i>Amphiprion frenatus</i>	Marine fish	Tomato anemonefish	Least Concern	Vulnerable	No	Construction	Loss/reduction of ecological connectivity for faunal movement	High	High	High	Unlikely	Negligible	High	High	Unlikely	Negligible
Faunal	Marine	<i>Amphiprion ocellaris</i>	Marine fish	Ocellaris clownfish / clown anemonefish	Not Assessed	Vulnerable	No	Construction	Loss/reduction of ecological connectivity for faunal movement	High	High	High	Unlikely	Negligible	High	High	Unlikely	Negligible
Faunal	Marine	<i>Amphiprion perideraion</i>	Marine fish	Pink skunk anemonefish	Least Concern	Vulnerable	No	Construction	Loss/reduction of ecological connectivity for faunal movement	High	High	High	Unlikely	Negligible	High	High	Unlikely	Negligible
Faunal	Marine	<i>Amphiprion polyommus</i>	Marine fish	Siddiback anemonefish	Least Concern	Vulnerable	No	Construction	Loss/reduction of ecological connectivity for faunal movement	High	High	High	Unlikely	Negligible	High	High	Unlikely	Negligible
Faunal	Marine	<i>Carcharias melanopterus</i>	Marine fish	Black tip reef shark	Vulnerable	Not Assessed	No	Construction	Loss/reduction of ecological connectivity for faunal movement	High	Low	Low	Unlikely	Negligible	Low	Low	Unlikely	Negligible
Faunal	Marine	<i>Chiloscyllium indium</i>	Marine fish	Slender bamboo shark	Vulnerable	Not Assessed	No	Construction	Loss/reduction of ecological connectivity for faunal movement	High	Low	Low	Unlikely	Negligible	Low	Low	Unlikely	Negligible
Faunal	Marine	<i>Himantura uauaki</i>	Marine fish	Honeycomb ray	Endangered	Not Assessed	No	Construction	Loss/reduction of ecological connectivity for faunal movement	High	High	High	Unlikely	Negligible	High	High	Unlikely	Negligible
Faunal	Marine	<i>Hippocampus comes</i>	Marine fish	Tiger tail seahorse	Vulnerable, CITES protected (Appendix II)	Vulnerable	No	Construction	Loss/reduction of ecological connectivity for faunal movement	High	High	High	Unlikely	Negligible	High	High	Unlikely	Negligible
Faunal	Marine	<i>Hippocampus kuda</i>	Marine fish	Estuarine seahorse / spotted seahorse	Not Assessed	Vulnerable	No	Construction	Loss/reduction of ecological connectivity for faunal movement	High	High	High	Unlikely	Negligible	High	High	Unlikely	Negligible
Faunal	Marine	<i>Rhinchobatus djiddensis</i>	Marine fish	White-spotted guitarfish	Critically Endangered	Not Assessed	No	Construction	Loss/reduction of ecological connectivity for faunal movement	High	High	High	Unlikely	Negligible	High	High	Unlikely	Negligible
Faunal	Marine	<i>Terena hardwickii</i>	Marine fish	Hardwick's electric ray	Vulnerable	Not Assessed	No	Construction	Loss/reduction of ecological connectivity for faunal movement	High	High	High	Unlikely	Negligible	High	High	Unlikely	Negligible
Faunal	Marine	<i>Acanthozoom sp.</i>	Marine flatworm	Spangled flatworm	NA	Vulnerable	No	Construction	Loss/reduction of ecological connectivity for faunal movement	High	High	High	Unlikely	Negligible	High	High	Unlikely	Negligible
Faunal	Marine	<i>Pseudoberos hancockanus</i>	Marine flatworm	Dawn flatworm	Not Assessed	Vulnerable	No	Construction	Loss/reduction of ecological connectivity for faunal movement	High	High	High	Unlikely	Negligible	High	High	Unlikely	Negligible
Faunal	Marine	<i>Pseudoberos stoffe</i>	Marine flatworm	Starry flatworm	Not Assessed	Vulnerable	No	Construction	Loss/reduction of ecological connectivity for faunal movement	High	High	High	Unlikely	Negligible	High	High	Unlikely	Negligible
Faunal	Marine	<i>Pseudoceros continus</i>	Marine flatworm	Elegant lined flatworm	Not Assessed	Vulnerable	No	Construction	Loss/reduction of ecological connectivity for faunal movement	High	High	High	Unlikely	Negligible	High	High	Unlikely	Negligible
Faunal	Marine	<i>Pseudoceros indicus</i>	Marine flatworm	Blue-dotted flatworm	Not Assessed	Vulnerable	No	Construction	Loss/reduction of ecological connectivity for faunal movement	High	High	High	Unlikely	Negligible	High	High	Unlikely	Negligible
Faunal	Marine	<i>Pseudoceros laingensis</i>	Marine flatworm	Purple-spotted flatworm	Not Assessed	Vulnerable	No	Construction	Loss/reduction of ecological connectivity for faunal movement	High	High	High	Unlikely	Negligible	High	High	Unlikely	Negligible
Faunal	Marine	<i>Typhloceros lazaridensis</i>	Marine flatworm	Olive flatworm	Not Assessed	Vulnerable	No	Construction	Loss/reduction of ecological connectivity for faunal movement	High	High	High	Unlikely	Negligible	High	High	Unlikely	Negligible
Faunal	Marine	<i>Acanthopora gemmata</i>	Marine gastropod	Jawelled chiton	Not Assessed	Endangered	No	Construction	Loss/reduction of ecological connectivity for faunal movement	High	High	High	Unlikely	Negligible	High	High	Unlikely	Negligible
Faunal	Marine	<i>Architectonika perspectiva</i>	Marine gastropod	Perspective sundial shell	Not Assessed	Endangered	No	Construction	Loss/reduction of ecological connectivity for faunal movement	High	High	High	Unlikely	Negligible	High	High	Unlikely	Negligible
Faunal	Marine	<i>Canarium urticus</i>	Marine gastropod	NA	Not Assessed	Vulnerable	No	Construction	Loss/reduction of ecological connectivity for faunal movement	High	High	High	Unlikely	Negligible	High	High	Unlikely	Negligible
Faunal	Marine	<i>Cerithium trailii</i>	Marine gastropod	Traill's cerith	Not Assessed	Endangered	No	Construction	Loss/reduction of ecological connectivity for faunal movement	High	High	High	Unlikely	Negligible	High	High	Unlikely	Negligible
Faunal	Marine	<i>Cymbiola nobilis</i>	Marine gastropod	Noble volute	Not Assessed	Vulnerable	No	Construction	Loss/reduction of ecological connectivity for faunal movement	High	High	High	Unlikely	Negligible	High	High	Unlikely	Negligible
Faunal	Marine	<i>Cypraea arabica</i>	Marine gastropod	Arabian cowrie	Not Assessed	Vulnerable	No	Construction	Loss/reduction of ecological connectivity for faunal movement	High	High	High	Unlikely	Negligible	High	High	Unlikely	Negligible
Faunal	Marine	<i>Cypraea tigris</i>	Marine gastropod	Tiger cowrie	Not Assessed	Endangered	No	Construction	Loss/reduction of ecological connectivity for faunal movement	High	High	High	Unlikely	Negligible	High	High	Unlikely	Negligible
Faunal	Marine	<i>Lentis lentis</i>	Marine gastropod	Spider conch	Not Assessed	Vulnerable	No	Construction	Loss/reduction of ecological connectivity for faunal movement	High	High	High	Unlikely	Negligible	High	High	Unlikely	Negligible
Faunal	Marine	<i>Melo melo</i>	Marine gastropod	Baller shell	Not Assessed	Endangered	No	Construction	Loss/reduction of ecological connectivity for faunal movement	High	High	High	Unlikely	Negligible	High	High	Unlikely	Negligible
Faunal	Marine	<i>Murex trapa</i>	Marine gastropod	Rare-spined murex	Endangered	Not Assessed	No	Construction	Loss/reduction of ecological connectivity for faunal movement	High	High	High	Unlikely	Negligible	High	High	Unlikely	Negligible
Faunal	Marine	<i>Nella planospira</i>	Marine gastropod	Flat-spired nerite	Not Assessed	Vulnerable	No	Construction	Loss/reduction of ecological connectivity for faunal movement	High	High	High	Unlikely	Negligible	High	High	Unlikely	Negligible
Faunal	Marine	<i>Phallium glaucum</i>	Marine gastropod	Grey bonnet	Not Assessed	Endangered	No	Construction	Loss/reduction of ecological connectivity for faunal movement	High	High	High	Unlikely	Negligible	High	High	Unlikely	Negligible
Faunal	Marine	<i>Scutus unguis</i>	Marine gastropod	Hoof-shield limpet	Not Assessed	Endangered	No	Construction	Loss/reduction of ecological connectivity for faunal movement	High	High	High	Unlikely	Negligible	High	High	Unlikely	Negligible
Faunal	Marine	<i>Strombus urticus</i>	Marine gastropod	Black-lipped conch	Not Assessed	Vulnerable	No	Construction	Loss/reduction of ecological connectivity for faunal movement	High	High	High	Unlikely	Negligible	High	High	Unlikely	Negligible
Faunal	Marine	<i>Trivia oryza</i>	Marine gastropod	NA	Not Assessed	Endangered	No	Construction	Loss/reduction of ecological connectivity for faunal movement	High	High	High	Unlikely	Negligible	High	High	Unlikely	Negligible
Faunal	Marine	<i>Triviastra oryza</i>	Marine gastropod	NA	Not Assessed	Endangered	No	Construction	Loss/reduction of ecological connectivity for faunal movement	High	High	High	Unlikely	Negligible	High	High	Unlikely	Negligible
Faunal	Marine	<i>Trochus nitidus</i>	Marine gastropod	NA	Not Assessed	Vulnerable	No	Construction	Loss/reduction of ecological connectivity for faunal movement	High	High	High	Unlikely	Negligible	High	High	Unlikely	Negligible
Faunal	Marine	<i>Cithon oustaliane</i>	Marine gastropod	NA	Least Concern	Vulnerable	Yes	Construction	Loss/reduction of ecological connectivity for faunal movement	High	High	High	Unlikely	Negligible	High	High	Unlikely	Negligible
Faunal	Marine	<i>Dugong dugon</i>	Marine mammal	Dugong	Vulnerable	Critically Endangered	No	Construction	Loss/reduction of ecological connectivity for faunal movement	High	High	High	Unlikely	Negligible	High	High	Unlikely	Negligible
Faunal	Marine	<i>Megascops phocaenoides</i>	Marine mammal	Finless porpoise	Vulnerable	Critically Endangered	No	Construction	Loss/reduction of ecological connectivity for faunal movement	High	High	High	Unlikely	Negligible	High	High	Unlikely	Negligible
Faunal	Marine	<i>Orcella brevirostris</i>	Marine mammal	Irrawaddy dolphin	Vulnerable	Critically Endangered	No	Construction	Loss/reduction of ecological connectivity for faunal movement	High	High	High	Unlikely	Negligible	High	High	Unlikely	Negligible
Faunal	Marine	<i>Sousa chinensis</i>	Marine mammal	Indo-pacific humpbacked dolphin	Near Threatened	Critically Endangered	No	Construction	Loss/reduction of ecological connectivity for faunal movement	High	High	High	Unlikely	Negligible	High	High	Unlikely	Negligible
Faunal	Marine	<i>Tursiops aduncus</i>	Marine mammal	Indo-pacific bottlenose dolphin	Data Deficient	Critically Endangered	No	Construction	Loss/reduction of ecological connectivity for faunal movement	High	High	High	Unlikely	Negligible	High	High	Unlikely	Negligible
Faunal	Marine	<i>Pantodonermis sp.</i>	Marine ribbon worm	NA	Not Assessed	Endangered	No	Construction	Loss/reduction of ecological connectivity for faunal movement	High	High	High	Unlikely	Negligible	High	High	Unlikely	Negligible
Faunal	Marine	<i>Athanas japonicus</i>	Marine shrimp	NA	Not Assessed	Vulnerable	No	Construction	Loss/reduction of ecological connectivity for faunal movement	High	High	High	Unlikely	Negligible	High	High	Unlikely	Negligible
Faunal	Marine	<i>Athanas polymorphus</i>	Marine shrimp	NA	Not Assessed	Vulnerable	No	Construction	Loss/reduction of ecological connectivity for faunal movement	High	High	High	Unlikely	Negligible	High	High	Unlikely	Negligible
Faunal	Marine	<i>Potamalpheops johnstoni</i>	Marine shrimp	NA	Not Assessed	Vulnerable	No	Construction	Loss/reduction of ecological connectivity for faunal movement	High	High	High	Unlikely	Negligible	High	High	Unlikely	Negligible
Faunal	Marine	<i>Potamalpheops tigger</i>	Marine shrimp	NA	Not Assessed	Vulnerable	No	Construction	Loss/reduction of ecological connectivity for faunal movement	High	High	High	Unlikely	Negligible	High	High	Unlikely	Negligible
Faunal	Marine	<i>Salmonus singaporensis</i>	Marine shrimp	NA	Not Assessed	Critically Endangered	No	Construction	Loss/reduction of ecological connectivity for faunal movement	High	High	High	Unlikely	Negligible	High	High	Unlikely	Negligible
Faunal	Marine	<i>Aplysina cyathus</i>	Marine sponge	Bristled sea sponge	Least Concern	Endangered	No	Construction	Loss/reduction of ecological connectivity for faunal movement	High	High	High	Unlikely	Negligible	High	High	Unlikely	Negligible
Faunal	Marine	<i>Stichopus hermanni</i>	Sea cucumber	Hermann's sea cucumber	Vulnerable	Not Assessed	No	Construction	Loss/reduction of ecological connectivity for faunal movement	High	High	High	Unlikely	Negligible	High	High	Unlikely	Negligible

Receptor Type	Type	Species	Taxon	Common name	Global status	National status	Recorded during field assessment?	Phase	Impact type	Sensitivity (S)	Impact Intensity (I)	Consequence (C = S x I)	Likelihood	Impact significance (C x L)	Residual impact intensity	Residual consequence	Residual likelihood	Residual impact significance
Faunal	Marine	<i>Echinaster callosus</i>	Sea star	Callous sea star	Not Assessed	Endangered	No	Construction	Loss/reduction of ecological connectivity for faunal movement	High	High	High	Unlikely	Negligible	High	High	Unlikely	Negligible
Faunal	Marine	<i>Luidia maculata</i>	Sea star	Eight-armed sea star	Not Assessed	Endangered	No	Construction	Loss/reduction of ecological connectivity for faunal movement	High	High	High	Unlikely	Negligible	High	High	Unlikely	Negligible
Faunal	Marine	<i>Protasterias nodosus</i>	Sea star	Knobby sea star, chocolate chip sea star	Not Assessed	Endangered	No	Construction	Loss/reduction of ecological connectivity for faunal movement	High	High	High	Unlikely	Negligible	High	High	Unlikely	Negligible
Faunal	Terrestrial	<i>Cyclodendrum adhaesivum</i>	Anemone	NA	Not Listed	Critically Endangered	No	Construction	Loss/reduction of ecological connectivity for faunal movement	High	High	High	Unlikely	Negligible	High	High	Unlikely	Negligible
Faunal	Terrestrial	<i>Heteractis crispa</i>	Anemone	Leathery anemone	Not Listed	Endangered	No	Construction	Loss/reduction of ecological connectivity for faunal movement	High	High	High	Unlikely	Negligible	High	High	Unlikely	Negligible
Faunal	Terrestrial	<i>Macroactylia dorsalis</i>	Anemone	Long tentacle anemone / corkscrew tentacle anemone / snaky	Not Listed	Endangered	No	Construction	Loss/reduction of ecological connectivity for faunal movement	High	High	High	Unlikely	Negligible	High	High	Unlikely	Negligible
Faunal	Terrestrial	<i>Emballonura monticola</i>	Bat	Lesser sheath-tailed bat	Least Concern	Critically Endangered	No	Construction	Loss/reduction of ecological connectivity for faunal movement	High	High	High	Unlikely	Negligible	High	High	Unlikely	Negligible
Faunal	Terrestrial	<i>Erycteris spelaea</i>	Bat	Cave nectar bat	Least Concern	Vulnerable	No	Construction	Loss/reduction of ecological connectivity for faunal movement	High	Medium	Medium	Unlikely	Negligible	Medium	Medium	Unlikely	Negligible
Faunal	Terrestrial	<i>Hipposideros cinerascens</i>	Bat	Ashy roundleaf bat	Least Concern	Critically Endangered	No	Construction	Loss/reduction of ecological connectivity for faunal movement	High	High	High	Unlikely	Negligible	High	High	Unlikely	Negligible
Faunal	Terrestrial	<i>Hypugo macrotis</i>	Bat	Big-eared pipistrelle	Data Deficient	Critically Endangered	No	Construction	Loss/reduction of ecological connectivity for faunal movement	High	High	High	Unlikely	Negligible	High	High	Unlikely	Negligible
Faunal	Terrestrial	<i>Macrognathus minimus</i>	Bat	Lesser long-tongued nectar bat	Least Concern	Vulnerable	No	Construction	Loss/reduction of ecological connectivity for faunal movement	High	High	High	Unlikely	Negligible	High	High	Unlikely	Negligible
Faunal	Terrestrial	<i>Megaderma spasma</i>	Bat	Lesser false-vampire	Least Concern	Endangered	No	Construction	Loss/reduction of ecological connectivity for faunal movement	High	High	High	Unlikely	Negligible	High	High	Unlikely	Negligible
Faunal	Terrestrial	<i>Pteropus variegatus</i>	Bat	Large flying fox	Near Threatened	Critically Endangered	No	Construction	Loss/reduction of ecological connectivity for faunal movement	High	Negligible	Very Low	Unlikely	Negligible	Negligible	Very Low	Unlikely	Negligible
Faunal	Terrestrial	<i>Taphozous longimanus</i>	Bat	Long-winged tomb bat	Least Concern	Critically Endangered	No	Construction	Loss/reduction of ecological connectivity for faunal movement	High	Low	Low	Unlikely	Negligible	Low	Low	Unlikely	Negligible
Faunal	Terrestrial	<i>Tytonchotis malayana</i>	Bat	Great ear bamboo bat	Least Concern	Vulnerable	No	Construction	Loss/reduction of ecological connectivity for faunal movement	High	High	High	Unlikely	Negligible	High	High	Unlikely	Negligible
Faunal	Terrestrial	<i>Acipiter trivirgatus</i>	Bird	Orested goshawk	Least Concern	Near Threatened	No	Construction	Loss/reduction of ecological connectivity for faunal movement	High	Low	Low	Unlikely	Negligible	Low	Low	Unlikely	Negligible
Faunal	Terrestrial	<i>Alcedo meninting</i>	Bird	Blue-eared kingfisher	Least Concern	Endangered	No	Construction	Loss/reduction of ecological connectivity for faunal movement	High	High	High	Unlikely	Negligible	High	High	Unlikely	Negligible
Faunal	Terrestrial	<i>Ardea purpurea</i>	Bird	Purple heron	Least Concern	Endangered	No	Construction	Loss/reduction of ecological connectivity for faunal movement	High	Low	Low	Unlikely	Negligible	Low	Low	Unlikely	Negligible
Faunal	Terrestrial	<i>Cacomantis sepulchralis</i>	Bird	Rusty-breasted cuckoo	Least Concern	Near Threatened	No	Construction	Loss/reduction of ecological connectivity for faunal movement	High	Medium	Medium	Unlikely	Negligible	Medium	Medium	Unlikely	Negligible
Faunal	Terrestrial	<i>Colaptes pygmaeus</i>	Bird	Spoon-billed sandpiper	Critically Endangered	Critically Endangered	No	Construction	Loss/reduction of ecological connectivity for faunal movement	High	Negligible	Very Low	Unlikely	Negligible	Negligible	Very Low	Unlikely	Negligible
Faunal	Terrestrial	<i>Callitis leucostriata</i>	Bird	Great kink	Endangered	Endangered	No	Construction	Loss/reduction of ecological connectivity for faunal movement	High	Negligible	Very Low	Unlikely	Negligible	Negligible	Very Low	Unlikely	Negligible
Faunal	Terrestrial	<i>Charadrius peronii</i>	Bird	Malaysian plover	Near Threatened	Critically Endangered	No	Construction	Loss/reduction of ecological connectivity for faunal movement	High	Low	Low	Unlikely	Negligible	Low	Low	Unlikely	Negligible
Faunal	Terrestrial	<i>Chrysococcyx xanthonchus</i>	Bird	Violet cuckoo	Least Concern	Vulnerable	No	Construction	Loss/reduction of ecological connectivity for faunal movement	High	High	High	Unlikely	Negligible	High	High	Unlikely	Negligible
Faunal	Terrestrial	<i>Cyanus brunneatus</i>	Bird	Brown-chested jungle flycatcher	Vulnerable	Vulnerable	No	Construction	Loss/reduction of ecological connectivity for faunal movement	High	Negligible	Very Low	Unlikely	Negligible	Negligible	Very Low	Unlikely	Negligible
Faunal	Terrestrial	<i>Cyanus ruficastris</i>	Bird	Mangrove blue flycatcher	Least Concern	Critically Endangered	No	Construction	Loss/reduction of ecological connectivity for faunal movement	High	High	High	Unlikely	Negligible	High	High	Unlikely	Negligible
Faunal	Terrestrial	<i>Egretta vulpophotes</i>	Bird	Chinese egret	Vulnerable	Endangered	No	Construction	Loss/reduction of ecological connectivity for faunal movement	High	Negligible	Very Low	Unlikely	Negligible	Negligible	Very Low	Unlikely	Negligible
Faunal	Terrestrial	<i>Galus galus</i>	Bird	Red junglefowl	Least Concern	Near Threatened	No	Construction	Loss/reduction of ecological connectivity for faunal movement	High	Low	Low	Unlikely	Negligible	Low	Low	Unlikely	Negligible
Faunal	Terrestrial	<i>Halcyon coronata</i>	Bird	Ruddy kingfisher	Least Concern	Critically Endangered	No	Construction	Loss/reduction of ecological connectivity for faunal movement	High	High	High	Unlikely	Negligible	High	High	Unlikely	Negligible
Faunal	Terrestrial	<i>Haliaeetus leucorhynchus</i>	Bird	Grey-headed fish eagle	Near Threatened	Vulnerable	No	Construction	Loss/reduction of ecological connectivity for faunal movement	High	Low	Low	Unlikely	Negligible	Low	Low	Unlikely	Negligible
Faunal	Terrestrial	<i>Kelops kelops</i>	Bird	Buffy fish owl	Least Concern	Vulnerable	No	Construction	Loss/reduction of ecological connectivity for faunal movement	High	Medium	Medium	Unlikely	Negligible	Medium	Medium	Unlikely	Negligible
Faunal	Terrestrial	<i>Leptoptilos javanicus</i>	Bird	Lesser adjutant	Vulnerable	Vulnerable	No	Construction	Loss/reduction of ecological connectivity for faunal movement	High	Negligible	Very Low	Unlikely	Negligible	Negligible	Very Low	Unlikely	Negligible
Faunal	Terrestrial	<i>Loriculus galeatus</i>	Bird	Blue-crowned hanging parrot	Least Concern	Least Concern	No	Construction	Loss/reduction of ecological connectivity for faunal movement	High	Low	Low	Unlikely	Negligible	Low	Low	Unlikely	Negligible
Faunal	Terrestrial	<i>Numenius madagascariensis</i>	Bird	Far eastern curlew	Endangered	Endangered	No	Construction	Loss/reduction of ecological connectivity for faunal movement	High	Negligible	Very Low	Unlikely	Negligible	Negligible	Very Low	Unlikely	Negligible
Faunal	Terrestrial	<i>Nycticorax nycticorax</i>	Bird	Black-crowned night heron	Least Concern	Endangered	No	Construction	Loss/reduction of ecological connectivity for faunal movement	High	Medium	Medium	Unlikely	Negligible	Medium	Medium	Unlikely	Negligible
Faunal	Terrestrial	<i>Pitta megarhynchos</i>	Bird	Mangrove pitta	Near Threatened	Critically Endangered	No	Construction	Loss/reduction of ecological connectivity for faunal movement	High	High	High	Unlikely	Negligible	High	High	Unlikely	Negligible
Faunal	Terrestrial	<i>Ptilinopus longicauda</i>	Bird	Long-tailed parakeet	Vulnerable	Near Threatened	No	Construction	Loss/reduction of ecological connectivity for faunal movement	High	Low	Low	Unlikely	Negligible	Low	Low	Unlikely	Negligible
Faunal	Terrestrial	<i>Rallina fasciata</i>	Bird	Red-legged crane	Least Concern	Near Threatened	No	Construction	Loss/reduction of ecological connectivity for faunal movement	High	High	High	Unlikely	Negligible	High	High	Unlikely	Negligible
Faunal	Terrestrial	<i>Spilornis cheela</i>	Bird	Orested serpent eagle	Least Concern	Critically Endangered	No	Construction	Loss/reduction of ecological connectivity for faunal movement	High	Low	Low	Unlikely	Negligible	Low	Low	Unlikely	Negligible
Faunal	Terrestrial	<i>Sterna sumatrana</i>	Bird	Black-naped tern	Least Concern	Endangered	No	Construction	Loss/reduction of ecological connectivity for faunal movement	High	Low	Low	Unlikely	Negligible	Low	Low	Unlikely	Negligible
Faunal	Terrestrial	<i>Sterna albifrons</i>	Bird	Little tern	Least Concern	Endangered	No	Construction	Loss/reduction of ecological connectivity for faunal movement	High	High	High	Unlikely	Negligible	High	High	Unlikely	Negligible
Faunal	Terrestrial	<i>Tringa guttifer</i>	Bird	Nordmann's greenshank	Endangered	Endangered	No	Construction	Loss/reduction of ecological connectivity for faunal movement	High	Negligible	Very Low	Unlikely	Negligible	Negligible	Very Low	Unlikely	Negligible
Faunal	Terrestrial	<i>Anthracoceros albinotus</i>	Bird	Oriental pied hornbill	Least Concern	Near Threatened	Yes	Construction	Loss/reduction of ecological connectivity for faunal movement	High	Low	Low	Unlikely	Negligible	Low	Low	Unlikely	Negligible
Faunal	Terrestrial	<i>Ardea cinerea</i>	Bird	Grey heron	Least Concern	Least Concern	Yes	Construction	Loss/reduction of ecological connectivity for faunal movement	High	Low	Low	Unlikely	Negligible	Low	Low	Unlikely	Negligible
Faunal	Terrestrial	<i>Ardea sumatrana</i>	Bird	Great-billed heron	Least Concern	Critically Endangered	Yes	Construction	Loss/reduction of ecological connectivity for faunal movement	High	Medium	Medium	Unlikely	Negligible	Medium	Medium	Unlikely	Negligible
Faunal	Terrestrial	<i>Coppychus malabaricus</i>	Bird	White-rumped shama	Least Concern	Endangered	Yes	Construction	Loss/reduction of ecological connectivity for faunal movement	High	High	High	Unlikely	Negligible	High	High	Unlikely	Negligible
Faunal	Terrestrial	<i>Coppychus saularis</i>	Bird	Oriental magpie-robin	Least Concern	Vulnerable	Yes	Construction	Loss/reduction of ecological connectivity for faunal movement	High	Low	Low	Unlikely	Negligible	Low	Low	Unlikely	Negligible
Faunal	Terrestrial	<i>Nisus arboreus</i>	Bird	Changeable hawk-eagle	Least Concern	Vulnerable	Yes	Construction	Loss/reduction of ecological connectivity for faunal movement	High	Low	Low	Unlikely	Negligible	Low	Low	Unlikely	Negligible
Faunal	Terrestrial	<i>Pyromonotus alpinus</i>	Bird	Straw-headed bulbul	Critically Endangered	Endangered	Yes	Construction	Loss/reduction of ecological connectivity for faunal movement	High	High	High	Unlikely	Negligible	High	High	Unlikely	Negligible
Faunal	Terrestrial	<i>Argopis amphirhina amphirhina</i>	Butterfly	NA	Not Listed	Nationally Extinct (Rediscovered)	No	Construction	Loss/reduction of ecological connectivity for faunal movement	High	Medium	Medium	Unlikely	Negligible	Medium	Medium	Unlikely	Negligible
Faunal	Terrestrial	<i>Ariadne aridae aridae</i>	Butterfly	Angled castor	Not Listed	Nationally Extinct (Rediscovered)	No	Construction	Loss/reduction of ecological connectivity for faunal movement	High	Negligible	Very Low	Unlikely	Negligible	Negligible	Very Low	Unlikely	Negligible
Faunal	Terrestrial	<i>Asitopterus jama jama</i>	Butterfly	Forest hopper	Not Listed	Nationally Extinct (Rediscovered)	No	Construction	Loss/reduction of ecological connectivity for faunal movement	High	Negligible	Very Low	Unlikely	Negligible	Negligible	Very Low	Unlikely	Negligible
Faunal	Terrestrial	<i>Bubo chinensis</i>	Butterfly	Formosan swift	Endangered	Not Listed	No	Construction	Loss/reduction of ecological connectivity for faunal movement	High	Negligible	Very Low	Unlikely	Negligible	Negligible	Very Low	Unlikely	Negligible
Faunal	Terrestrial	<i>Callitis malaya</i>	Butterfly	Malayan swift	Not Listed	Nationally Extinct (Rediscovered)	No	Construction	Loss/reduction of ecological connectivity for faunal movement	High	Medium	Medium	Unlikely	Negligible	Medium	Medium	Unlikely	Negligible
Faunal	Terrestrial	<i>Catopyrops anyra</i>	Butterfly	Anyra blue	Not Listed	Vulnerable	No	Construction	Loss/reduction of ecological connectivity for faunal movement	High	Low	Low	Unlikely	Negligible	Low	Low	Unlikely	Negligible
Faunal	Terrestrial	<i>Catantopius asama asama</i>	Butterfly	White-banded flat	Not Listed	Nationally Extinct (Rediscovered)	No	Construction	Loss/reduction of ecological connectivity for faunal movement	High	High	High	Unlikely	Negligible	High	High	Unlikely	Negligible
Faunal	Terrestrial	<i>Cephenes acalis niasicus</i>	Butterfly	Plain palm dart	Not Listed	Nationally Extinct (Rediscovered)	No	Construction	Loss/reduction of ecological connectivity for faunal movement	High	Negligible	Very Low	Unlikely	Negligible	Negligible	Very Low	Unlikely	Negligible
Faunal	Terrestrial	<i>Cethosia methysa</i>	Butterfly	Plain lacewing	Not Listed	Critically Endangered	No	Construction	Loss/reduction of ecological connectivity for faunal movement	High	Medium	Medium	Unlikely	Negligible	Medium	Medium	Unlikely	Negligible
Faunal	Terrestrial	<i>Diosphora sandaka despolita</i>	Butterfly	Common duffer	Not Listed	Critically Endangered	No	Construction	Loss/reduction of ecological connectivity for faunal movement	High	High	High	Unlikely	Negligible	High	High	Unlikely	Negligible
Faunal	Terrestrial	<i>Idea isouane chersonesia</i>	Butterfly	Mangrove tree nymph	Not Listed	Critically Endangered	No	Construction	Loss/reduction of ecological connectivity for faunal movement	High	High	High	Unlikely	Negligible	High	High	Unlikely	Negligible
Faunal	Terrestrial	<i>Janides alcyon ageladas</i>	Butterfly	Metallic caerulean	Not Listed	Nationally Extinct (Rediscovered)	No	Construction	Loss/reduction of ecological connectivity for faunal movement	High	Low	Low	Unlikely	Negligible	Low	Low	Unlikely	Negligible
Faunal	Terrestrial	<i>Nacaduba kurava romana</i>	Butterfly	Transparent sialine blue	Not Listed	Nationally Extinct (Rediscovered)	No	Construction	Loss/reduction of ecological connectivity for faunal movement	High	Negligible	Very Low	Unlikely	Negligible	Negligible	Very Low	Unlikely	Negligible
Faunal	Terrestrial	<i>Nacaduba puctulax odon</i>	Butterfly	Large fourline blue	Not Listed	Nationally Extinct (Rediscovered)	No	Construction	Loss/reduction of ecological connectivity for faunal movement	High	High	High	Unlikely	Negligible	High	High	Unlikely	Negligible

Receptor Type	Type	Species	Taxon	Common name	Global status	National status	Recorded during field assessment?	Phase	Impact type	Sensitivity (S)	Impact Intensity (I)	Consequence (C = S x I)	Likelihood	Impact significance (C x L)	Residual impact intensity	Residual consequence	Residual Likelihood	Residual impact significance
Faunal	Terrestrial	<i>Pachylia arctolachiae asteris</i>	Butterfly	Common rose	Not Listed	Vulnerable	No	Construction	Loss/reduction of ecological connectivity for faunal movement	High	Negligible	Very Low	Unlikely	Negligible	Negligible	Very Low	Unlikely	Negligible
Faunal	Terrestrial	<i>Pantilia aspasia aspasia</i>	Butterfly	Yellow glassy tiger	Not Listed	Nationally Extinct (Rediscovered)	No	Construction	Loss/reduction of ecological connectivity for faunal movement	High	Negligible	Very Low	Unlikely	Negligible	Negligible	Very Low	Unlikely	Negligible
Faunal	Terrestrial	<i>Pteronia vakata luteicornis</i>	Butterfly	Wanderer	Not Listed	Nationally Extinct (Rediscovered)	No	Construction	Loss/reduction of ecological connectivity for faunal movement	High	Negligible	Very Low	Unlikely	Negligible	Negligible	Very Low	Unlikely	Negligible
Faunal	Terrestrial	<i>Polopidas agna agna</i>	Butterfly	Bengal swift	Not Listed	Endangered	No	Construction	Loss/reduction of ecological connectivity for faunal movement	High	Negligible	Very Low	Unlikely	Negligible	Negligible	Very Low	Unlikely	Negligible
Faunal	Terrestrial	<i>Potanthus trachali tyleri</i>	Butterfly	Detached dart	Not Listed	Nationally Extinct (Rediscovered)	No	Construction	Loss/reduction of ecological connectivity for faunal movement	High	Negligible	Very Low	Unlikely	Negligible	Negligible	Very Low	Unlikely	Negligible
Faunal	Terrestrial	<i>Rachana jilindra burbona</i>	Butterfly	Banded royal	Not Listed	Critically Endangered	No	Construction	Loss/reduction of ecological connectivity for faunal movement	High	Medium	Medium	Unlikely	Negligible	Medium	Medium	Unlikely	Negligible
Faunal	Terrestrial	<i>Salsus every every</i>	Butterfly	White palm bob	Not Listed	Endangered	No	Construction	Loss/reduction of ecological connectivity for faunal movement	High	High	High	Unlikely	Negligible	High	High	Unlikely	Negligible
Faunal	Terrestrial	<i>Telicta color stigma</i>	Butterfly	Common palm dart	Not Listed	Nationally Extinct (Rediscovered)	No	Construction	Loss/reduction of ecological connectivity for faunal movement	High	Negligible	Very Low	Unlikely	Negligible	Negligible	Very Low	Unlikely	Negligible
Faunal	Terrestrial	<i>Trotes helena cebonus</i>	Butterfly	Common birdwing	Not Listed	Vulnerable	No	Construction	Loss/reduction of ecological connectivity for faunal movement	High	Negligible	Very Low	Unlikely	Negligible	Negligible	Very Low	Unlikely	Negligible
Faunal	Terrestrial	<i>Euplexes lullulus lederei</i>	Butterfly	Dwarf crow	Not Listed	Endangered	Yes	Construction	Loss/reduction of ecological connectivity for faunal movement	High	High	High	Unlikely	Negligible	High	High	Unlikely	Negligible
Faunal	Terrestrial	<i>Graphium doxan everonoides</i>	Butterfly	Common jay	Not Listed	Not Evaluated	Yes	Construction	Loss/reduction of ecological connectivity for faunal movement	High	Low	Low	Unlikely	Negligible	Low	Low	Unlikely	Negligible
Faunal	Terrestrial	<i>Papua moori moori</i>	Butterfly	Malayan reasab	Not Listed	Nationally Extinct (Rediscovered)	Yes	Construction	Loss/reduction of ecological connectivity for faunal movement	High	Negligible	Very Low	Unlikely	Negligible	Negligible	Very Low	Unlikely	Negligible
Faunal	Terrestrial	<i>Morionagrion arthuri</i>	Damselfly	Arthur's midget	Near Threatened	Vulnerable	Yes	Construction	Loss/reduction of ecological connectivity for faunal movement	High	High	High	Unlikely	Negligible	High	High	Unlikely	Negligible
Faunal	Terrestrial	<i>Anax parybous</i>	Dragonfly	Arrow emperor	Least Concern	Least Concern	No	Construction	Loss/reduction of ecological connectivity for faunal movement	High	High	High	Unlikely	Negligible	High	High	Unlikely	Negligible
Faunal	Terrestrial	<i>Oreochromis mossambicus</i>	Freshwater fish	Common / Mozambique tilapia	Vulnerable	Not Evaluated	No	Construction	Loss/reduction of ecological connectivity for faunal movement	High	High	High	Unlikely	Negligible	High	High	Unlikely	Negligible
Faunal	Terrestrial	<i>Conobita viduata</i>	Hermit crab	Land hermit crab	Not Listed	Vulnerable	No	Construction	Loss/reduction of ecological connectivity for faunal movement	High	High	High	Unlikely	Negligible	High	High	Unlikely	Negligible
Faunal	Terrestrial	<i>Thalassina anomala</i>	Mud lobster	NA	Not Listed	Endangered	No	Construction	Loss/reduction of ecological connectivity for faunal movement	High	High	High	Unlikely	Negligible	High	High	Unlikely	Negligible
Faunal	Terrestrial	<i>Thalassina gracilis</i>	Mud lobster	NA	Not Listed	Endangered	No	Construction	Loss/reduction of ecological connectivity for faunal movement	High	High	High	Unlikely	Negligible	High	High	Unlikely	Negligible
Faunal	Terrestrial	<i>Waffogobia phuketensis</i>	Mud shrimp	NA	Not Listed	Endangered	NA	Construction	Loss/reduction of ecological connectivity for faunal movement	High	High	High	Unlikely	Negligible	High	High	Unlikely	Negligible
Faunal	Terrestrial	<i>Aonyx cheirus</i>	Non-marine mammal	Oriental small-clawed otter	Vulnerable	Critically Endangered	No	Construction	Loss/reduction of ecological connectivity for faunal movement	High	High	High	Unlikely	Negligible	High	High	Unlikely	Negligible
Faunal	Terrestrial	<i>Myotis brachyura</i>	Non-marine mammal	Malayan porcupine	Least Concern	Critically Endangered	No	Construction	Loss/reduction of ecological connectivity for faunal movement	High	High	High	Unlikely	Negligible	High	High	Unlikely	Negligible
Faunal	Terrestrial	<i>Meris javanica</i>	Non-marine mammal	Sunda pangolin	Critically Endangered	Critically Endangered	No	Construction	Loss/reduction of ecological connectivity for faunal movement	High	Medium	Medium	Unlikely	Negligible	Medium	Medium	Unlikely	Negligible
Faunal	Terrestrial	<i>Lutrogale perspicillata</i>	Non-marine mammal	Smooth otter	Vulnerable	Endangered	Yes	Construction	Loss/reduction of ecological connectivity for faunal movement	High	Negligible	Very Low	Unlikely	Negligible	Negligible	Very Low	Unlikely	Negligible
Faunal	Terrestrial	<i>Macaca fascicularis</i>	Non-marine mammal	Long-tailed macaque	Endangered	Least Concern	Yes	Construction	Loss/reduction of ecological connectivity for faunal movement	High	Negligible	Very Low	Unlikely	Negligible	Negligible	Very Low	Unlikely	Negligible
Faunal	Terrestrial	<i>Prionailurus bengalensis</i>	Non-marine mammal	Jopard cat	Least Concern	Critically Endangered	No	Construction	Loss/reduction of ecological connectivity for faunal movement	High	High	High	Unlikely	Negligible	High	High	Unlikely	Negligible
Faunal	Terrestrial	<i>Tragulus napu</i>	Non-marine mammal	Greater mousedeer	Least Concern	Critically Endangered	Yes	Construction	Loss/reduction of ecological connectivity for faunal movement	High	High	High	Unlikely	Negligible	High	High	Unlikely	Negligible
Faunal	Terrestrial	<i>Boiga cynodon</i>	Non-marine snake	Dog-toothed cat snake	Least Concern	Vulnerable	No	Construction	Loss/reduction of ecological connectivity for faunal movement	High	High	High	Unlikely	Negligible	High	High	Unlikely	Negligible
Faunal	Terrestrial	<i>Boiga melanota</i>	Non-marine snake	Gold-ringed cat snake	Least Concern	Vulnerable	No	Construction	Loss/reduction of ecological connectivity for faunal movement	High	High	High	Unlikely	Negligible	High	High	Unlikely	Negligible
Faunal	Terrestrial	<i>Bungarus fasciatus</i>	Non-marine snake	Banded krait	Least Concern	Endangered	No	Construction	Loss/reduction of ecological connectivity for faunal movement	High	High	High	Unlikely	Negligible	High	High	Unlikely	Negligible
Faunal	Terrestrial	<i>Dryophops rubescens</i>	Non-marine snake	Keel-bellied whip snake	Least Concern	Endangered	No	Construction	Loss/reduction of ecological connectivity for faunal movement	High	High	High	Unlikely	Negligible	High	High	Unlikely	Negligible
Faunal	Terrestrial	<i>Silybopsis melanostephus</i>	Non-marine snake	Black-headed collared snake	Least Concern	Vulnerable	No	Construction	Loss/reduction of ecological connectivity for faunal movement	High	High	High	Unlikely	Negligible	High	High	Unlikely	Negligible
Faunal	Terrestrial	<i>Thriresaurus purpureomaculatus</i>	Non-marine snake	Shore pit viper	Least Concern	Vulnerable	No	Construction	Loss/reduction of ecological connectivity for faunal movement	High	High	High	Unlikely	Negligible	High	High	Unlikely	Negligible
Faunal	Terrestrial	<i>Agropyphis mudfroi</i>	Non-marine snake	White-bellied blind snake	Least Concern	Critically Endangered	Yes	Construction	Loss/reduction of ecological connectivity for faunal movement	High	High	High	Unlikely	Negligible	High	High	Unlikely	Negligible
Faunal	Terrestrial	<i>Cuora amboinensis</i>	Non-marine turtle	Malayan box terrapin	Endangered	Near Threatened	No	Construction	Loss/reduction of ecological connectivity for faunal movement	High	High	High	Unlikely	Negligible	High	High	Unlikely	Negligible
Faunal	Marine	<i>Vismus ater</i>	Freshwater gastropod	NA	Least Concern	Vulnerable	No	Operational	Human disturbances	High	Negligible	Very Low	Unlikely	Negligible	Negligible	Very Low	Unlikely	Negligible
Faunal	Marine	<i>Gyrisulus barkeri</i>	Freshwater gastropod	NA	Vulnerable	Not Assessed	NA	Operational	Human disturbances	High	Negligible	Very Low	Unlikely	Negligible	Negligible	Very Low	Unlikely	Negligible
Faunal	Marine	<i>Lachryphos gigas</i>	Horseshoe crab	NA	Data Deficient	Vulnerable	Yes	Operational	Human disturbances	High	Negligible	Very Low	Unlikely	Negligible	Negligible	Very Low	Unlikely	Negligible
Faunal	Marine	<i>Carcharias rotundicauda</i>	Shark	Great white shark	Not Assessed	Vulnerable	Not Assessed	Operational	Human disturbances	High	Negligible	Very Low	Unlikely	Negligible	Negligible	Very Low	Unlikely	Negligible
Faunal	Marine	<i>Pinna aculeata</i>	Marine bivalve	Two-coloured fan shell	Not Assessed	Vulnerable	Not Assessed	Operational	Human disturbances	High	Negligible	Very Low	Unlikely	Negligible	Low	Low	Unlikely	Negligible
Faunal	Marine	<i>Pinna muricea</i>	Marine bivalve	Pinna muricea	Not Assessed	Vulnerable	Not Assessed	Operational	Human disturbances	High	Negligible	Very Low	Unlikely	Negligible	Low	Low	Unlikely	Negligible
Faunal	Marine	<i>Tridacna squamosa</i>	Marine bivalve	Plumed giant clam	Not Assessed	CITES protected (Appendix II)	Endangered	Operational	Human disturbances	High	Negligible	Very Low	Unlikely	Negligible	Low	Low	Unlikely	Negligible
Faunal	Marine	<i>Atrypa reticularis</i>	Marine crab	NA	Not Assessed	Vulnerable	NA	Operational	Human disturbances	High	Negligible	Very Low	Unlikely	Negligible	Negligible	Very Low	Unlikely	Negligible
Faunal	Marine	<i>Atrypa reticularis</i>	Marine crab	Red leg crab	Not Assessed	Vulnerable	No	Operational	Human disturbances	High	Negligible	Very Low	Unlikely	Negligible	Negligible	Very Low	Unlikely	Negligible
Faunal	Marine	<i>Callinectes sapidus</i>	Marine crab	NA	Not Assessed	Vulnerable	NA	Operational	Human disturbances	High	Negligible	Very Low	Unlikely	Negligible	Negligible	Very Low	Unlikely	Negligible
Faunal	Marine	<i>Callinectes sapidus</i>	Marine crab	NA	Not Assessed	Vulnerable	NA	Operational	Human disturbances	High	Negligible	Very Low	Unlikely	Negligible	Negligible	Very Low	Unlikely	Negligible
Faunal	Marine	<i>Callinectes sapidus</i>	Marine crab	NA	Not Assessed	Vulnerable	NA	Operational	Human disturbances	High	Negligible	Very Low	Unlikely	Negligible	Negligible	Very Low	Unlikely	Negligible
Faunal	Marine	<i>Callinectes sapidus</i>	Marine crab	NA	Not Assessed	Vulnerable	NA	Operational	Human disturbances	High	Negligible	Very Low	Unlikely	Negligible	Negligible	Very Low	Unlikely	Negligible
Faunal	Marine	<i>Callinectes sapidus</i>	Marine crab	NA	Not Assessed	Vulnerable	NA	Operational	Human disturbances	High	Negligible	Very Low	Unlikely	Negligible	Negligible	Very Low	Unlikely	Negligible
Faunal	Marine	<i>Callinectes sapidus</i>	Marine crab	NA	Not Assessed	Vulnerable	NA	Operational	Human disturbances	High	Negligible	Very Low	Unlikely	Negligible	Negligible	Very Low	Unlikely	Negligible
Faunal	Marine	<i>Callinectes sapidus</i>	Marine crab	NA	Not Assessed	Vulnerable	NA	Operational	Human disturbances	High	Negligible	Very Low	Unlikely	Negligible	Negligible	Very Low	Unlikely	Negligible
Faunal	Marine	<i>Callinectes sapidus</i>	Marine crab	NA	Not Assessed	Vulnerable	NA	Operational	Human disturbances	High	Negligible	Very Low	Unlikely	Negligible	Negligible	Very Low	Unlikely	Negligible
Faunal	Marine	<i>Callinectes sapidus</i>	Marine crab	NA	Not Assessed	Vulnerable	NA	Operational	Human disturbances	High	Negligible	Very Low	Unlikely	Negligible	Negligible	Very Low	Unlikely	Negligible
Faunal	Marine	<i>Callinectes sapidus</i>	Marine crab	NA	Not Assessed	Vulnerable	NA	Operational	Human disturbances	High	Negligible	Very Low	Unlikely	Negligible	Negligible	Very Low	Unlikely	Negligible
Faunal	Marine	<i>Callinectes sapidus</i>	Marine crab	NA	Not Assessed	Vulnerable	NA	Operational	Human disturbances	High	Negligible	Very Low	Unlikely	Negligible	Negligible	Very Low	Unlikely	Negligible
Faunal	Marine	<i>Callinectes sapidus</i>	Marine crab	NA	Not Assessed	Vulnerable	NA	Operational	Human disturbances	High	Negligible	Very Low	Unlikely	Negligible	Negligible	Very Low	Unlikely	Negligible
Faunal	Marine	<i>Callinectes sapidus</i>	Marine crab	NA	Not Assessed	Vulnerable	NA	Operational	Human disturbances	High	Negligible	Very Low	Unlikely	Negligible	Negligible	Very Low	Unlikely	Negligible
Faunal	Marine	<i>Callinectes sapidus</i>	Marine crab	NA	Not Assessed	Vulnerable	NA	Operational	Human disturbances	High	Negligible	Very Low	Unlikely	Negligible	Negligible	Very Low	Unlikely	Negligible
Faunal	Marine	<i>Callinectes sapidus</i>	Marine crab	NA	Not Assessed	Vulnerable	NA	Operational	Human disturbances	High	Negligible	Very Low	Unlikely	Negligible	Negligible	Very Low	Unlikely	Negligible
Faunal	Marine	<i>Callinectes sapidus</i>	Marine crab	NA	Not Assessed	Vulnerable	NA	Operational	Human disturbances	High	Negligible	Very Low	Unlikely	Negligible	Negligible	Very Low	Unlikely	Negligible
Faunal	Marine	<i>Callinectes sapidus</i>	Marine crab	NA	Not Assessed	Vulnerable	NA	Operational	Human disturbances	High	Negligible	Very Low	Unlikely	Negligible	Negligible	Very Low	Unlikely	Negligible
Faunal	Marine	<i>Callinectes sapidus</i>	Marine crab	NA	Not Assessed	Vulnerable	NA	Operational	Human disturbances	High	Negligible	Very Low	Unlikely	Negligible	Negligible	Very Low	Unlikely	Negligible
Faunal	Marine	<i>Callinectes sapidus</i>	Marine crab	NA	Not Assessed	Vulnerable	NA	Operational	Human disturbances	High	Negligible	Very Low	Unlikely	Negligible	Negligible	Very Low	Unlikely	Negligible
Faunal	Marine	<i>Callinectes sapidus</i>	Marine crab	NA	Not Assessed	Vulnerable	NA	Operational	Human disturbances	High	Negligible	Very Low	Unlikely	Negligible	Negligible	Very Low	Unlikely	Negligible
Faunal	Marine	<i>Callinectes sapidus</i>	Marine crab	NA	Not Assessed	Vulnerable	NA	Operational	Human disturbances	High	Negligible	Very Low	Unlikely	Negligible	Negligible	Very Low	Unlikely	Negligible
Faunal	Marine	<i>Callinectes sapidus</i>	Marine crab	NA	Not Assessed	Vulnerable	NA	Operational	Human disturbances	High	Negligible	Very Low	Unlikely	Negligible	Negligible	Very Low	Unlikely	Negligible
Faunal	Marine	<i>Callinectes sapidus</i>	Marine crab	NA	Not Assessed	Vulnerable	NA	Operational	Human disturbances	High	Negligible	Very Low	Unlikely	Negligible	Negligible	Very Low	Unlikely	Negligible
Faunal	Marine	<i>Callinectes sapidus</i>	Marine crab	NA	Not Assessed	Vulnerable	NA	Operational	Human disturbances	High	Negligible	Very Low	Unlikely	Negligible	Negligible	Very Low	Unlikely	Negligible
Faunal	Marine	<i>Callinectes sapidus</i>	Marine crab	NA	Not Assessed	Vulnerable	NA	Operational	Human disturbances	High	Negligible	Very Low	Unlikely	Negligible	Negligible	Very Low	Unlikely	Negligible
Faunal	Marine	<i>Callinectes sapidus</i>	Marine crab	NA	Not Assessed	Vulnerable	NA	Operational	Human disturbances	High	Negligible	Very Low	Unlikely	Negligible	Negligible	Very Low	Unlikely	Negligible
Faunal	Marine	<i>Callinectes sapidus</i>	Marine crab	NA	Not Assessed	Vulnerable	NA	Operational	Human disturbances	High	Negligible	Very Low	Unlikely	Negligible	Negligible	Very Low	Unlikely	Negligible

Receptor Type	Type	Species	Taxon	Common name	Global status	National status	Recorded during field assessment?	Phase	Impact type	Sensitivity (S)	Impact Intensity (I)	Consequence (C) as per 11	Likelihood	Impact significance	Residual impact intensity	Residual consequence	Residual Likelihood	Residual impact significance
Faunal	Marine	<i>Nephotocoma phocaenoides</i>	Marine mammal	Finnish porpoise	Vulnerable	Critically Endangered	No	Operational	Human disturbances	High	Negligible	Very Low	Unlikely	Negligible	Negligible	Very Low	Unlikely	Negligible
Faunal	Marine	<i>Orcella brevirostris</i>	Marine mammal	Irrawaddy dolphin	Vulnerable	Critically Endangered	No	Operational	Human disturbances	High	Negligible	Very Low	Unlikely	Negligible	Negligible	Very Low	Unlikely	Negligible
Faunal	Marine	<i>Sousa chinensis</i>	Marine mammal	Indo-pacific humpbacked dolphin	Near Threatened	Critically Endangered	No	Operational	Human disturbances	High	Negligible	Very Low	Unlikely	Negligible	Negligible	Very Low	Unlikely	Negligible
Faunal	Marine	<i>Tursiops aduncus</i>	Marine mammal	Indo-pacific bottlenose dolphin	Data Deficient	Critically Endangered	No	Operational	Human disturbances	High	Negligible	Very Low	Unlikely	Negligible	Negligible	Very Low	Unlikely	Negligible
Faunal	Marine	<i>Pastinacosmerus sp</i>	Marine ribbon worm	NA	Not Assessed	Endangered	No	Operational	Human disturbances	High	Negligible	Very Low	Unlikely	Negligible	Negligible	Very Low	Unlikely	Negligible
Faunal	Marine	<i>Athanas japonicus</i>	Marine shrimp	NA	Not Assessed	Vulnerable	NA	Operational	Human disturbances	High	Negligible	Very Low	Unlikely	Negligible	Negligible	Very Low	Unlikely	Negligible
Faunal	Marine	<i>Athanas polyomphalus</i>	Marine shrimp	NA	Not Assessed	Vulnerable	NA	Operational	Human disturbances	High	Negligible	Very Low	Unlikely	Negligible	Negligible	Very Low	Unlikely	Negligible
Faunal	Marine	<i>Polysiphonia shimoni</i>	Marine shrimp	NA	Not Assessed	Vulnerable	NA	Operational	Human disturbances	High	Negligible	Very Low	Unlikely	Negligible	Negligible	Very Low	Unlikely	Negligible
Faunal	Marine	<i>Polysiphonia zigzag</i>	Marine shrimp	NA	Not Assessed	Vulnerable	NA	Operational	Human disturbances	High	Negligible	Very Low	Unlikely	Negligible	Negligible	Very Low	Unlikely	Negligible
Faunal	Marine	<i>Salmonus shigapomensis</i>	Marine shrimp	NA	Not Assessed	Critically Endangered	No	Operational	Human disturbances	High	Negligible	Very Low	Unlikely	Negligible	Negligible	Very Low	Unlikely	Negligible
Faunal	Marine	<i>Alipynus cyboides</i>	Marine snake	Bearded sea snake	Least Concern	Endangered	No	Operational	Human disturbances	High	Negligible	Very Low	Unlikely	Negligible	Negligible	Very Low	Unlikely	Negligible
Faunal	Marine	<i>Scleropus hermanni</i>	Sea cucumber	Hermann's sea cucumber	Vulnerable	Not Assessed	No	Operational	Human disturbances	High	Negligible	Very Low	Unlikely	Negligible	Negligible	Very Low	Unlikely	Negligible
Faunal	Marine	<i>Echinocystites</i>	Sea star	Callous sea star	Not Assessed	Endangered	No	Operational	Human disturbances	High	Negligible	Very Low	Unlikely	Negligible	Negligible	Very Low	Unlikely	Negligible
Faunal	Marine	<i>Luffia mizuhaia</i>	Sea star	Light-armed sea star	Not Assessed	Endangered	No	Operational	Human disturbances	High	Negligible	Very Low	Unlikely	Negligible	Negligible	Very Low	Unlikely	Negligible
Faunal	Marine	<i>Polydora rotunda</i>	Sea star	Knobby sea star, chocolate chip sea star	Not Assessed	Endangered	No	Operational	Human disturbances	High	Negligible	Very Low	Unlikely	Negligible	Negligible	Very Low	Unlikely	Negligible
Faunal	Terrestrial	<i>Cyrtopodium adhaesivum</i>	Anemone	NA	Not Listed	Critically Endangered	No	Operational	Human disturbances	High	Negligible	Very Low	Unlikely	Negligible	Negligible	Very Low	Unlikely	Negligible
Faunal	Terrestrial	<i>Hexacorals crapa</i>	Anemone	Leathery anemone	Not Listed	Endangered	No	Operational	Human disturbances	High	Negligible	Very Low	Unlikely	Negligible	Negligible	Very Low	Unlikely	Negligible
Faunal	Terrestrial	<i>Macrocladia domensis</i>	Anemone	Long tentacle anemone / cork coral / tentacle anemone / snaky	Not Listed	Endangered	No	Operational	Human disturbances	High	Negligible	Very Low	Unlikely	Negligible	Negligible	Very Low	Unlikely	Negligible
Faunal	Terrestrial	<i>Emballonura monticola</i>	Bat	Lesser sheath-tailed bat	Least Concern	Critically Endangered	No	Operational	Human disturbances	High	Medium	Medium	Unlikely	Negligible	Negligible	Very Low	Unlikely	Negligible
Faunal	Terrestrial	<i>Eonycteris spelaea</i>	Bat	Cave nectar bat	Least Concern	Vulnerable	NA	Operational	Human disturbances	High	Medium	Medium	Unlikely	Negligible	Negligible	Very Low	Unlikely	Negligible
Faunal	Terrestrial	<i>Hipposideros ater</i>	Bat	Ashy roundleaf bat	Least Concern	Critically Endangered	No	Operational	Human disturbances	High	Medium	Medium	Unlikely	Negligible	Negligible	Very Low	Unlikely	Negligible
Faunal	Terrestrial	<i>Hypsignathos</i>	Bat	Big-eared pigmy shrew	Data Deficient	Critically Endangered	No	Operational	Human disturbances	High	Medium	Medium	Unlikely	Negligible	Negligible	Very Low	Unlikely	Negligible
Faunal	Terrestrial	<i>Macroglossus rufinus</i>	Bat	Lesser long-tongued nectar bat	Least Concern	Vulnerable	NA	Operational	Human disturbances	High	Medium	Medium	Unlikely	Negligible	Negligible	Very Low	Unlikely	Negligible
Faunal	Terrestrial	<i>Megaderma spasma</i>	Bat	Lesser false-vampire	Least Concern	Endangered	No	Operational	Human disturbances	High	Medium	Medium	Unlikely	Negligible	Negligible	Very Low	Unlikely	Negligible
Faunal	Terrestrial	<i>Pteropus vampyrus</i>	Bat	Large flying fox	Near Threatened	Critically Endangered	No	Operational	Human disturbances	High	Medium	Medium	Unlikely	Negligible	Negligible	Very Low	Unlikely	Negligible
Faunal	Terrestrial	<i>Taphozous longimanus</i>	Bat	Long-winged tomb bat	Least Concern	Critically Endangered	No	Operational	Human disturbances	High	Medium	Medium	Unlikely	Negligible	Negligible	Very Low	Unlikely	Negligible
Faunal	Terrestrial	<i>Urophyllum malaysianum</i>	Bat	Greater bamboo bat	Least Concern	Vulnerable	NA	Operational	Human disturbances	High	Medium	Medium	Unlikely	Negligible	Negligible	Very Low	Unlikely	Negligible
Faunal	Terrestrial	<i>Asiaticus nigripes</i>	Bird	Crested shrike	Least Concern	Near Threatened	No	Operational	Human disturbances	High	Medium	Medium	Less likely	Minor	Negligible	Very Low	Unlikely	Minor
Faunal	Terrestrial	<i>Alcedo malayana</i>	Bird	Blue-headed kingfisher	Least Concern	Endangered	No	Operational	Human disturbances	High	High	High	Less likely	Minor	Negligible	Very Low	Unlikely	Minor
Faunal	Terrestrial	<i>Ardea purpurea</i>	Bird	Purple heron	Least Concern	Endangered	No	Operational	Human disturbances	High	Medium	Medium	Less likely	Minor	Negligible	Very Low	Unlikely	Minor
Faunal	Terrestrial	<i>Cacomantis sepulchralis</i>	Bird	Bush-breasted cuckoo	Near Threatened	Endangered	No	Operational	Human disturbances	High	High	High	Less likely	Minor	Negligible	Very Low	Unlikely	Minor
Faunal	Terrestrial	<i>Calcis pygmaea</i>	Bird	Spoon-billed sandpiper	Critically Endangered	Critically Endangered	No	Operational	Human disturbances	High	High	High	Less likely	Minor	Negligible	Very Low	Unlikely	Minor
Faunal	Terrestrial	<i>Calcis leucostriata</i>	Bird	Great knot	Endangered	Critically Endangered	No	Operational	Human disturbances	High	High	High	Less likely	Minor	Negligible	Very Low	Unlikely	Minor
Faunal	Terrestrial	<i>Charadrius peronii</i>	Bird	Malaysian plover	Near Threatened	Critically Endangered	No	Operational	Human disturbances	High	High	High	Less likely	Minor	Negligible	Very Low	Unlikely	Minor
Faunal	Terrestrial	<i>Chrysocolaptes xanthopychus</i>	Bird	White-crowned kingfisher	Least Concern	Vulnerable	NA	Operational	Human disturbances	High	High	High	Less likely	Minor	Negligible	Very Low	Unlikely	Minor
Faunal	Terrestrial	<i>Ceryle downii</i>	Bird	Brown-cheeked jungle flycatcher	Vulnerable	Endangered	No	Operational	Human disturbances	High	High	High	Less likely	Minor	Negligible	Very Low	Unlikely	Minor
Faunal	Terrestrial	<i>Ceyx fuliginosa</i>	Bird	Mangrove blue flycatcher	Least Concern	Critically Endangered	No	Operational	Human disturbances	High	High	High	Less likely	Minor	Negligible	Very Low	Unlikely	Minor
Faunal	Terrestrial	<i>Egretta subpallens</i>	Bird	Chinese egret	Vulnerable	Endangered	No	Operational	Human disturbances	High	Medium	Medium	Less likely	Minor	Negligible	Very Low	Unlikely	Minor
Faunal	Terrestrial	<i>Gallus gallus</i>	Bird	Red junglefowl	Least Concern	Near Threatened	No	Operational	Human disturbances	High	Low	Low	Less likely	Minor	Negligible	Very Low	Unlikely	Minor
Faunal	Terrestrial	<i>Halcyon coromanda</i>	Bird	Ruddy kingfisher	Least Concern	Critically Endangered	No	Operational	Human disturbances	High	High	High	Less likely	Minor	Negligible	Very Low	Unlikely	Minor
Faunal	Terrestrial	<i>Haliastur intermedius</i>	Bird	Grey-headed fish eagle	Near Threatened	Vulnerable	NA	Operational	Human disturbances	High	High	High	Less likely	Minor	Negligible	Very Low	Unlikely	Minor
Faunal	Terrestrial	<i>Elanus leucurus</i>	Bird	White-bellied eagle	Least Concern	Vulnerable	NA	Operational	Human disturbances	High	High	High	Less likely	Minor	Negligible	Very Low	Unlikely	Minor
Faunal	Terrestrial	<i>Lophotyx javanica</i>	Bird	Lesser adjutant	Least Concern	Vulnerable	NA	Operational	Human disturbances	High	High	High	Less likely	Minor	Negligible	Very Low	Unlikely	Minor
Faunal	Terrestrial	<i>Corvus leucurus</i>	Bird	Blue-crowned hanging parrot	Least Concern	Endangered	No	Operational	Human disturbances	High	High	High	Less likely	Minor	Negligible	Very Low	Unlikely	Minor
Faunal	Terrestrial	<i>Numenius tenuirostris</i>	Bird	Far eastern curlew	Endangered	Endangered	No	Operational	Human disturbances	High	High	High	Less likely	Minor	Negligible	Very Low	Unlikely	Minor
Faunal	Terrestrial	<i>Myiavarus ruficauda</i>	Bird	Black-crowned night heron	Least Concern	Endangered	No	Operational	Human disturbances	High	High	High	Less likely	Minor	Negligible	Very Low	Unlikely	Minor
Faunal	Terrestrial	<i>Pitta megarhynchos</i>	Bird	Mangrove pitta	Near Threatened	Critically Endangered	No	Operational	Human disturbances	High	High	High	Less likely	Minor	Negligible	Very Low	Unlikely	Minor
Faunal	Terrestrial	<i>Ptilinopus leucostriatus</i>	Bird	Long-tailed parakeet	Vulnerable	Near Threatened	No	Operational	Human disturbances	High	Medium	Medium	Less likely	Minor	Negligible	Very Low	Unlikely	Minor
Faunal	Terrestrial	<i>Scolia fasciata</i>	Bird	Red-legged crane	Least Concern	Near Threatened	No	Operational	Human disturbances	High	High	High	Less likely	Minor	Negligible	Very Low	Unlikely	Minor
Faunal	Terrestrial	<i>Sphenoceros</i>	Bird	Red-capped serpent eagle	Least Concern	Critically Endangered	No	Operational	Human disturbances	High	High	High	Less likely	Minor	Negligible	Very Low	Unlikely	Minor
Faunal	Terrestrial	<i>Sterna sumatrana</i>	Bird	Black-naped tern	Least Concern	Endangered	No	Operational	Human disturbances	High	High	High	Less likely	Minor	Negligible	Very Low	Unlikely	Minor
Faunal	Terrestrial	<i>Sterna bergii</i>	Bird	Lesser frigatebird	Least Concern	Endangered	No	Operational	Human disturbances	High	High	High	Less likely	Minor	Negligible	Very Low	Unlikely	Minor
Faunal	Terrestrial	<i>Troglodytes aedon</i>	Bird	Nordmann's greenhank	Endangered	Endangered	No	Operational	Human disturbances	High	High	High	Less likely	Minor	Negligible	Very Low	Unlikely	Minor
Faunal	Terrestrial	<i>Anthracoceros albertoni</i>	Bird	Oriental pied hornbill	Least Concern	Near Threatened	Yes	Operational	Human disturbances	High	Medium	Medium	Less likely	Minor	Negligible	Very Low	Unlikely	Minor
Faunal	Terrestrial	<i>Actitis macularia</i>	Bird	Great-billed heron	Least Concern	Endangered	Yes	Operational	Human disturbances	High	Medium	Medium	Less likely	Minor	Negligible	Very Low	Unlikely	Minor
Faunal	Terrestrial	<i>Actitis sumatrana</i>	Bird	Great-billed heron	Least Concern	Critically Endangered	Yes	Operational	Human disturbances	High	Medium	Medium	Less likely	Minor	Negligible	Very Low	Unlikely	Minor
Faunal	Terrestrial	<i>Coppychus malabaricus</i>	Bird	White-rumped shama	Least Concern	Endangered	Yes	Operational	Human disturbances	High	High	High	Less likely	Minor	Negligible	Very Low	Unlikely	Minor
Faunal	Terrestrial	<i>Coppychus saularis</i>	Bird	Oriental magpie robin	Least Concern	Vulnerable	Yes	Operational	Human disturbances	High	Medium	Medium	Less likely	Minor	Negligible	Very Low	Unlikely	Minor
Faunal	Terrestrial	<i>Phapitreron trichotis</i>	Bird	Threepointed black eagle	Least Concern	Endangered	Yes	Operational	Human disturbances	High	Medium	Medium	Less likely	Minor	Negligible	Very Low	Unlikely	Minor
Faunal	Terrestrial	<i>Pycnonotus javanicus</i>	Bird	Sri-lankan bulbul	Critically Endangered	Endangered	Yes	Operational	Human disturbances	High	High	High	Less likely	Minor	Negligible	Very Low	Unlikely	Minor
Faunal	Terrestrial	<i>Arhopa amphirhoa amphirhoa</i>	Butterfly	NA	Not Listed	Nationally Extinct (Rediscovered)	No	Operational	Human disturbances	High	Low	Low	Unlikely	Negligible	Negligible	Very Low	Unlikely	Negligible
Faunal	Terrestrial	<i>Aristides aristides aristides</i>	Butterfly	Angled castor	Not Listed	Nationally Extinct (Rediscovered)	No	Operational	Human disturbances	High	Low	Low	Unlikely	Negligible	Negligible	Very Low	Unlikely	Negligible
Faunal	Terrestrial	<i>Astictopterus jama jama</i>	Butterfly	Forest hopper	Not Listed	Nationally Extinct (Rediscovered)	No	Operational	Human disturbances	High	Low	Low	Unlikely	Negligible	Negligible	Very Low	Unlikely	Negligible
Faunal	Terrestrial	<i>Bubo chinensis</i>	Butterfly	Common swift	Not Listed	Endangered	No	Operational	Human disturbances	High	Low	Low	Unlikely	Negligible	Negligible	Very Low	Unlikely	Negligible
Faunal	Terrestrial	<i>Calotis malaya</i>	Butterfly	Malayan swift	Not Listed	Nationally Extinct (Rediscovered)	No	Operational	Human disturbances	High	Low	Low	Unlikely	Negligible	Negligible	Very Low	Unlikely	Negligible
Faunal	Terrestrial	<i>Calopogon ancyra</i>	Butterfly	Ancya blue	Not Listed	Vulnerable	NA	Operational	Human disturbances	High	Low	Low	Unlikely	Negligible	Negligible	Very Low	Unlikely	Negligible
Faunal	Terrestrial	<i>Catantoprus samara samara</i>	Butterfly	White-banded flat	Not Listed	Nationally Extinct (Rediscovered)	No	Operational	Human disturbances	High	Low	Low	Unlikely	Negligible	Negligible	Very Low	Unlikely	Negligible
Faunal	Terrestrial	<i>Cephus acule naxosus</i>	Butterfly	Plain palm dart	Not Listed	Nationally Extinct (Rediscovered)	No	Operational	Human disturbances	High	Low	Low	Unlikely	Negligible	Negligible	Very Low	Unlikely	Negligible
Faunal	Terrestrial	<i>Cethosia methysa</i>	Butterfly	Plain lacewing	Not Listed	Critically Endangered	No	Operational	Human disturbances	High	Low	Low	Unlikely	Negligible	Negligible	Very Low	Unlikely	Negligible
Faunal	Terrestrial	<i>Dioptis sondaica depollata</i>	Butterfly	Common duffer	Not Listed	Critically Endangered	No	Operational	Human disturbances	High	Low	Low	Unlikely	Negligible	Negligible	Very Low	Unlikely	Negligible
Faunal	Terrestrial	<i>Ilex leucocarpa chersonesia</i>	Butterfly	Mangrove tree nymph	Not Listed	Critically Endangered	No	Operational	Human disturbances	High	Low	Low	Unlikely	Negligible	Negligible	Very Low	Unlikely	Negligible
Faunal	Terrestrial	<i>Jamides alecto agelades</i>	Butterfly	Metallic casulana	Not Listed	Nationally Extinct (Rediscovered)	No	Operational	Human disturbances	High	Low	Low	Unlikely	Negligible	Negligible	Very Low	Unlikely	Negligible
Faunal	Ter																	

Receptor Type	Type	Species	Taxon	Common name	Global status	National status	Recorded during field assessment?	Phase	Impact type	Sensitivity (S)	Impact Intensity (I)	Consequence (C) as per 8.1.1	Likelihood	Impact significance	Residual impact intensity	Residual consequence	Residual likelihood	Residual impact significance
Faunal	Terrestrial	<i>Oreodonta violacea</i>	Hermit crab	land hermit crab	Not Listed	Vulnerable	No	Operational	Human disturbances	High	Very Low	Unlikely	Negligible	Negligible	Very Low	Unlikely	Negligible	
Faunal	Terrestrial	<i>Thalassia anomala</i>	Mud lobster	NA	Not Listed	Endangered	No	Operational	Human disturbances	High	Negligible	Very Low	Unlikely	Negligible	Negligible	Very Low	Unlikely	Negligible
Faunal	Terrestrial	<i>Thalassia crassa</i>	Endangered	NA	Endangered	Endangered	No	Operational	Human disturbances	High	Negligible	Very Low	Unlikely	Negligible	Negligible	Very Low	Unlikely	Negligible
Faunal	Terrestrial	<i>Wolffocheilus phuketensis</i>	Mud shrimp	NA	Not Listed	Endangered	No	Operational	Human disturbances	High	Negligible	Very Low	Unlikely	Negligible	Negligible	Very Low	Unlikely	Negligible
Faunal	Terrestrial	<i>Aonyx cherius</i>	Non-marine mammal	Oriental small clawed otter	Vulnerable	Critically Endangered	No	Operational	Human disturbances	High	Medium	Medium	Unlikely	Negligible	Negligible	Very Low	Unlikely	Negligible
Faunal	Terrestrial	<i>Mytilus brachyura</i>	Non-marine mammal	Malayan porcupine	Least Concern	Critically Endangered	No	Operational	Human disturbances	High	High	High	Unlikely	Negligible	Negligible	Very Low	Unlikely	Negligible
Faunal	Terrestrial	<i>Meris javanica</i>	Non-marine mammal	Sunda pangolin	Critically Endangered	Critically Endangered	No	Operational	Human disturbances	High	Medium	Medium	Unlikely	Negligible	Negligible	Very Low	Unlikely	Negligible
Faunal	Terrestrial	<i>Colaptes peracappellii</i>	Non-marine mammal	Emboob color	Vulnerable	Endangered	Yes	Operational	Human disturbances	High	Medium	Medium	Unlikely	Negligible	Negligible	Very Low	Unlikely	Negligible
Faunal	Terrestrial	<i>Mascops chrysotis</i>	Non-marine mammal	Long-billed noddie	Least Concern	Least Concern	Yes	Operational	Human disturbances	High	Medium	Medium	Unlikely	Negligible	Negligible	Very Low	Unlikely	Negligible
Faunal	Terrestrial	<i>Prionailurus bengalensis</i>	Non-marine mammal	leopard cat	Least Concern	Critically Endangered	Yes	Operational	Human disturbances	High	High	High	Unlikely	Negligible	Negligible	Very Low	Unlikely	Negligible
Faunal	Terrestrial	<i>Tragulus napu</i>	Non-marine mammal	Great mouse deer	Least Concern	Endangered	Yes	Operational	Human disturbances	High	High	High	Unlikely	Negligible	Negligible	Very Low	Unlikely	Negligible
Faunal	Terrestrial	<i>Boswa arizonae</i>	Non-marine snake	Long toothed cat snake	Least Concern	Vulnerable	No	Operational	Human disturbances	High	Medium	Medium	Less likely	Minor	Negligible	Very Low	Unlikely	Minor
Faunal	Terrestrial	<i>Bolita phoenicea</i>	Non-marine snake	Gold-ringed cat snake	Least Concern	Vulnerable	No	Operational	Human disturbances	High	Medium	Medium	Less likely	Minor	Negligible	Very Low	Unlikely	Minor
Faunal	Terrestrial	<i>Rumohr fasciatus</i>	Non-marine snake	Banded krait	Least Concern	Endangered	No	Operational	Human disturbances	High	Medium	Medium	Less likely	Minor	Negligible	Very Low	Unlikely	Minor
Faunal	Terrestrial	<i>Ophichthus snake</i>	Non-marine snake	Keel-bellied whipsnake	Least Concern	Endangered	No	Operational	Human disturbances	High	Medium	Medium	Less likely	Minor	Negligible	Very Low	Unlikely	Minor
Faunal	Terrestrial	<i>Siphonops melanostomus</i>	Non-marine snake	Black-headed collared snake	Least Concern	Vulnerable	No	Operational	Human disturbances	High	Medium	Medium	Less likely	Minor	Negligible	Very Low	Unlikely	Minor
Faunal	Terrestrial	<i>Trimrasurus purpureomaculatus</i>	Non-marine snake	Shore pit viper	Least Concern	Vulnerable	No	Operational	Human disturbances	High	Medium	Medium	Less likely	Minor	Negligible	Very Low	Unlikely	Minor
Faunal	Terrestrial	<i>Argyrophis muelleri</i>	Non-marine snake	White-bellied blind snake	Least Concern	Critically Endangered	Yes	Operational	Human disturbances	High	Medium	Medium	Less likely	Minor	Negligible	Very Low	Unlikely	Minor
Faunal	Terrestrial	<i>Cuora amboinensis</i>	Non-marine turtle	Malayan box terrapin	Endangered	Near Threatened	No	Operational	Human disturbances	High	High	Low	Possible	Minor	Negligible	Very Low	Unlikely	Minor
Faunal	Marine	<i>Fauna aler</i>	Freshwater gastropod	NA	Least Concern	Vulnerable	No	Operational	Human-wildlife conflict	High	Negligible	Very Low	Unlikely	Negligible	Negligible	Very Low	Unlikely	Negligible
Faunal	Marine	<i>Gyalulus batesi</i>	Freshwater gastropod	NA	Least Concern	Not Assessed	No	Operational	Human-wildlife conflict	High	Negligible	Very Low	Unlikely	Negligible	Negligible	Very Low	Unlikely	Negligible
Faunal	Marine	<i>Hydrobia ulvae</i>	Hydrobia crab	NA	Data Deficient	Not Assessed	NA	Operational	Human-wildlife conflict	High	Negligible	Very Low	Unlikely	Minor	Negligible	Very Low	Unlikely	Negligible
Faunal	Marine	<i>Caricocorbis rubrohaudata</i>	Hydrobia crab	NA	Vulnerable	Not Assessed	NA	Operational	Human-wildlife conflict	High	Negligible	Very Low	Unlikely	Minor	Negligible	Very Low	Unlikely	Negligible
Faunal	Marine	<i>Pinna aculor</i>	Marine bivalve	Two-coloured turk shell	Not Assessed	Vulnerable	No	Operational	Human-wildlife conflict	High	Negligible	Very Low	Unlikely	Negligible	Negligible	Very Low	Unlikely	Negligible
Faunal	Marine	<i>Pinna muricata</i>	Marine bivalve	NA	Not Assessed	Vulnerable	No	Operational	Human-wildlife conflict	High	Negligible	Very Low	Unlikely	Negligible	Negligible	Very Low	Unlikely	Negligible
Faunal	Marine	<i>Tridacna squamosa</i>	Marine bivalve	ridged giant clam	Not Assessed	Critically Endangered	NA	Operational	Human-wildlife conflict	High	Negligible	Very Low	Unlikely	Negligible	Negligible	Very Low	Unlikely	Negligible
Faunal	Marine	<i>Alivata flavidus</i>	Marine crab	NA	Not Assessed	Vulnerable	No	Operational	Human-wildlife conflict	High	Negligible	Very Low	Unlikely	Negligible	Negligible	Very Low	Unlikely	Negligible
Faunal	Marine	<i>Alivata maculata</i>	Marine crab	Red egg crab	Not Assessed	Vulnerable	No	Operational	Human-wildlife conflict	High	Negligible	Very Low	Unlikely	Negligible	Negligible	Very Low	Unlikely	Negligible
Faunal	Marine	<i>Callinectes hepatica</i>	Marine crab	NA	Not Assessed	Vulnerable	No	Operational	Human-wildlife conflict	High	Negligible	Very Low	Unlikely	Negligible	Negligible	Very Low	Unlikely	Negligible
Faunal	Marine	<i>Callinectes philippinus</i>	Marine crab	NA	Not Assessed	Vulnerable	No	Operational	Human-wildlife conflict	High	Negligible	Very Low	Unlikely	Negligible	Negligible	Very Low	Unlikely	Negligible
Faunal	Marine	<i>Callinectes sinensis</i>	Marine crab	NA	Not Assessed	Vulnerable	No	Operational	Human-wildlife conflict	High	Negligible	Very Low	Unlikely	Negligible	Negligible	Very Low	Unlikely	Negligible
Faunal	Marine	<i>Loxochinus pilosus</i>	Marine crab	Mosaic crab	Not Assessed	Endangered	No	Operational	Human-wildlife conflict	High	Negligible	Very Low	Unlikely	Negligible	Negligible	Very Low	Unlikely	Negligible
Faunal	Marine	<i>Polypodium granulosum</i>	Marine crab	NA	Not Assessed	Endangered	No	Operational	Human-wildlife conflict	High	Negligible	Very Low	Unlikely	Negligible	Negligible	Very Low	Unlikely	Negligible
Faunal	Marine	<i>Phidippinus pelagicus</i>	Marine crab	Common claw crab	Not Assessed	Vulnerable	No	Operational	Human-wildlife conflict	High	Negligible	Very Low	Unlikely	Negligible	Negligible	Very Low	Unlikely	Negligible
Faunal	Marine	<i>Sarmanium gemmati</i>	Marine crab	NA	Not Assessed	Endangered	NA	Operational	Human-wildlife conflict	High	Negligible	Very Low	Unlikely	Negligible	Negligible	Very Low	Unlikely	Negligible
Faunal	Marine	<i>Uca rosea</i>	Marine crab	Blue fiddler crab	Not Assessed	Endangered	No	Operational	Human-wildlife conflict	High	Negligible	Very Low	Unlikely	Negligible	Negligible	Very Low	Unlikely	Negligible
Faunal	Marine	<i>Alpheidae dark</i>	Marine crab	Blue's amonemfish	Not Assessed	Vulnerable	No	Operational	Human-wildlife conflict	High	Negligible	Very Low	Unlikely	Negligible	Negligible	Very Low	Unlikely	Negligible
Faunal	Marine	<i>Amphiona reticulata</i>	Marine fish	Tomah amonemfish	Least Concern	Vulnerable	No	Operational	Human-wildlife conflict	High	Negligible	Very Low	Unlikely	Negligible	Negligible	Very Low	Unlikely	Negligible
Faunal	Marine	<i>Chromis cyanostriata</i>	Marine fish	Cyanostriata damselfish	Least Concern	Vulnerable	No	Operational	Human-wildlife conflict	High	Negligible	Very Low	Unlikely	Negligible	Negligible	Very Low	Unlikely	Negligible
Faunal	Marine	<i>Amphiona purpurata</i>	Marine fish	Pink slunk amonemfish	Least Concern	Vulnerable	No	Operational	Human-wildlife conflict	High	Negligible	Very Low	Unlikely	Negligible	Negligible	Very Low	Unlikely	Negligible
Faunal	Marine	<i>Amphiona polyzona</i>	Marine fish	Saddleback amonemfish	Least Concern	Vulnerable	No	Operational	Human-wildlife conflict	High	Negligible	Very Low	Unlikely	Negligible	Negligible	Very Low	Unlikely	Negligible
Faunal	Marine	<i>Chromis melanopus</i>	Marine fish	Black-lined shark	Least Concern	Not Assessed	No	Operational	Human-wildlife conflict	High	Negligible	Very Low	Unlikely	Negligible	Negligible	Very Low	Unlikely	Negligible
Faunal	Marine	<i>Chromis melanopus</i>	Marine fish	Black-lined shark	Least Concern	Not Assessed	No	Operational	Human-wildlife conflict	High	Negligible	Very Low	Unlikely	Negligible	Negligible	Very Low	Unlikely	Negligible
Faunal	Marine	<i>Chromis melanopus</i>	Marine fish	Shesher bamboo shark	Vulnerable	Not Assessed	No	Operational	Human-wildlife conflict	High	Negligible	Very Low	Unlikely	Negligible	Negligible	Very Low	Unlikely	Negligible
Faunal	Marine	<i>Hemirhamphus virgatus</i>	Marine fish	Homogrouper ray	Endangered	Not Assessed	No	Operational	Human-wildlife conflict	High	Negligible	Very Low	Unlikely	Negligible	Negligible	Very Low	Unlikely	Negligible
Faunal	Marine	<i>Hippocampus comes</i>	Marine fish	Four-tailed seahorse	Vulnerable	CITES S protected (Appendix II)	No	Operational	Human-wildlife conflict	High	Negligible	Very Low	Unlikely	Negligible	Negligible	Very Low	Unlikely	Negligible
Faunal	Marine	<i>Hippocampus kuda</i>	Marine fish	Luarine seahorse / spotted seahorse	Vulnerable	Not Assessed	No	Operational	Human-wildlife conflict	High	Negligible	Very Low	Unlikely	Negligible	Negligible	Very Low	Unlikely	Negligible
Faunal	Marine	<i>Hippocampus glaudius</i>	Marine fish	White-spotted garterfish	Critically Endangered	Not Assessed	No	Operational	Human-wildlife conflict	High	Negligible	Very Low	Unlikely	Negligible	Negligible	Very Low	Unlikely	Negligible
Faunal	Marine	<i>Hippocampus barackleyi</i>	Marine fish	Haddock's electric ray	Vulnerable	Not Assessed	No	Operational	Human-wildlife conflict	High	Negligible	Very Low	Unlikely	Negligible	Negligible	Very Low	Unlikely	Negligible
Faunal	Marine	<i>Asiatrachium sp.</i>	Marine flatworm	Spined flatworm	NA	Vulnerable	No	Operational	Human-wildlife conflict	High	Negligible	Very Low	Unlikely	Negligible	Negligible	Very Low	Unlikely	Negligible
Faunal	Marine	<i>Pseudoceros bancroftianus</i>	Marine flatworm	Swain flatworm	Not Assessed	Vulnerable	No	Operational	Human-wildlife conflict	High	Negligible	Very Low	Unlikely	Negligible	Negligible	Very Low	Unlikely	Negligible
Faunal	Marine	<i>Pseudoceros sticticus</i>	Marine flatworm	Starry flatworm	Not Assessed	Vulnerable	No	Operational	Human-wildlife conflict	High	Negligible	Very Low	Unlikely	Negligible	Negligible	Very Low	Unlikely	Negligible
Faunal	Marine	<i>Pseudoceros concoloratus</i>	Marine flatworm	Elephant flat flatworm	Not Assessed	Vulnerable	No	Operational	Human-wildlife conflict	High	Negligible	Very Low	Unlikely	Negligible	Negligible	Very Low	Unlikely	Negligible
Faunal	Marine	<i>Pseudoceros ruber</i>	Marine flatworm	Blue-spotted flatworm	Not Assessed	Vulnerable	No	Operational	Human-wildlife conflict	High	Negligible	Very Low	Unlikely	Negligible	Negligible	Very Low	Unlikely	Negligible
Faunal	Marine	<i>Pseudoceros laevis</i>	Marine flatworm	Purple-spotted flatworm	Not Assessed	Vulnerable	No	Operational	Human-wildlife conflict	High	Negligible	Very Low	Unlikely	Negligible	Negligible	Very Low	Unlikely	Negligible
Faunal	Marine	<i>Typhlocyba bicoloratus</i>	Marine flatworm	Oliver flatworm	Not Assessed	Vulnerable	No	Operational	Human-wildlife conflict	High	Negligible	Very Low	Unlikely	Negligible	Negligible	Very Low	Unlikely	Negligible
Faunal	Marine	<i>Acetabularia geminata</i>	Marine gastropod	Wedged Chiton	Not Assessed	Endangered	No	Operational	Human-wildlife conflict	High	Negligible	Very Low	Unlikely	Negligible	Negligible	Very Low	Unlikely	Negligible
Faunal	Marine	<i>Archiactinia perspicua</i>	Marine gastropod	Prospective sundial shell	Not Assessed	Endangered	No	Operational	Human-wildlife conflict	High	Negligible	Very Low	Unlikely	Negligible	Negligible	Very Low	Unlikely	Negligible
Faunal	Marine	<i>Callinectes ornatus</i>	Marine gastropod	NA	Not Assessed	Vulnerable	No	Operational	Human-wildlife conflict	High	Negligible	Very Low	Unlikely	Negligible	Negligible	Very Low	Unlikely	Negligible
Faunal	Marine	<i>Callinectes ornatus</i>	Marine gastropod	Callinectes ornatus	Not Assessed	Vulnerable	No	Operational	Human-wildlife conflict	High	Negligible	Very Low	Unlikely	Negligible	Negligible	Very Low	Unlikely	Negligible
Faunal	Marine	<i>Cyrtolites nobilis</i>	Marine gastropod	Notie whelie	Not Assessed	Vulnerable	No	Operational	Human-wildlife conflict	High	Negligible	Very Low	Unlikely	Negligible	Negligible	Very Low	Unlikely	Negligible
Faunal	Marine	<i>Cyrtolites nobilis</i>	Marine gastropod	Notie whelie	Not Assessed	Vulnerable	No	Operational	Human-wildlife conflict	High	Negligible	Very Low	Unlikely	Negligible	Negligible	Very Low	Unlikely	Negligible
Faunal	Marine	<i>Cyrtolites nobilis</i>	Marine gastropod	Notie whelie	Not Assessed	Vulnerable	No	Operational	Human-wildlife conflict	High	Negligible	Very Low	Unlikely	Negligible	Negligible	Very Low	Unlikely	Negligible
Faunal	Marine	<i>Cyrtolites nobilis</i>	Marine gastropod	Notie whelie	Not Assessed	Vulnerable	No	Operational	Human-wildlife conflict	High	Negligible	Very Low	Unlikely	Negligible	Negligible	Very Low	Unlikely	Negligible
Faunal	Marine	<i>Larrea tridentata</i>	Marine gastropod	Four-pointed shell	Not Assessed	Vulnerable	No	Operational	Human-wildlife conflict	High	Negligible	Very Low	Unlikely	Negligible	Negligible	Very Low	Unlikely	Negligible
Faunal	Marine	<i>Larrea tridentata</i>	Marine gastropod	Spider conch	Not Assessed	Vulnerable	No	Operational	Human-wildlife conflict	High	Negligible	Very Low	Unlikely	Negligible	Negligible	Very Low	Unlikely	Negligible
Faunal	Marine	<i>Larrea tridentata</i>	Marine gastropod	Butter shell	Not Assessed	Vulnerable	No	Operational	Human-wildlife conflict	High	Negligible	Very Low	Unlikely	Negligible	Negligible	Very Low	Unlikely	Negligible
Faunal	Marine	<i>Larrea tridentata</i>	Marine gastropod	Bare-spined nodule	Endangered	Not Assessed	No	Operational	Human-wildlife conflict	High	Negligible	Very Low	Unlikely	Negligible	Negligible	Very Low	Unlikely	Negligible
Faunal	Marine	<i>Nerita pilosipira</i>	Marine gastropod	Flat spin neri	Not Assessed	Vulnerable	No	Operational	Human-wildlife conflict	High	Negligible	Very Low	Unlikely	Negligible	Negligible	Very Low	Unlikely	Negligible
Faunal	Marine	<i>Phidippinus pelagicus</i>	Marine gastropod	Cricket	Not Assessed	Vulnerable	No	Operational	Human-wildlife conflict	High	Negligible	Very Low	Unlikely	Negligible	Negligible</			

Receptor Type	Type	Species	Taxon	Common name	Global status	National status	Recorded during field assessment?	Phase	Impact type	Sensitivity (S)	Impact Intensity (I)	Consequence (C = S x I)	Likelihood	Impact significance (C x L)	Residual impact intensity	Residual consequence	Residual likelihood	Residual impact significance	
Faunal	Terrestrial	<i>Charadrius peronii</i>	Bird	Malaysian plover	Near Threatened	Critically Endangered	No	Operational	Human-wildlife conflict	High	Negligible	Very Low	Unlikely	Negligible	Negligible	Very Low	Unlikely	Negligible	
Faunal	Terrestrial	<i>Chrysocolaptes anthracinus</i>	Bird	Molot cuckoo	Least Concern	Vulnerable	No	Operational	Human-wildlife conflict	High	Negligible	Very Low	Unlikely	Negligible	Negligible	Very Low	Unlikely	Negligible	
Faunal	Terrestrial	<i>Cynops burneyi</i>	Bird	Brown-chested jungle flycatcher	Vulnerable	Vulnerable	No	Operational	Human-wildlife conflict	High	Negligible	Very Low	Unlikely	Negligible	Negligible	Very Low	Unlikely	Negligible	
Faunal	Terrestrial	<i>Cynops ruficastris</i>	Bird	Mangrove blue flycatcher	Least Concern	Critically Endangered	No	Operational	Human-wildlife conflict	High	Negligible	Very Low	Unlikely	Negligible	Negligible	Very Low	Unlikely	Negligible	
Faunal	Terrestrial	<i>Lycetta subpallens</i>	Bird	Chinese egret	Vulnerable	Endangered	No	Operational	Human-wildlife conflict	High	Negligible	Very Low	Unlikely	Negligible	Negligible	Very Low	Unlikely	Negligible	
Faunal	Terrestrial	<i>Colinus pulchellus</i>	Bird	Red-winged dove	Least Concern	Near Threatened	No	Operational	Human-wildlife conflict	High	Negligible	Very Low	Unlikely	Negligible	Negligible	Very Low	Unlikely	Negligible	
Faunal	Terrestrial	<i>Haliastur coromanda</i>	Bird	Ruddy kingfisher	Least Concern	Critically Endangered	No	Operational	Human-wildlife conflict	High	Negligible	Very Low	Unlikely	Negligible	Negligible	Very Low	Unlikely	Negligible	
Faunal	Terrestrial	<i>Haliaeetus leucorhynchus</i>	Bird	Grey-headed fish eagle	Near Threatened	Vulnerable	Endangered	No	Operational	Human-wildlife conflict	High	Negligible	Very Low	Less likely	Negligible	Negligible	Very Low	Unlikely	Negligible
Faunal	Terrestrial	<i>Kittaka kintaru</i>	Bird	Buffy fish owl	Least Concern	Vulnerable	No	Operational	Human-wildlife conflict	High	Negligible	Very Low	Unlikely	Negligible	Negligible	Very Low	Unlikely	Negligible	
Faunal	Terrestrial	<i>Catopoxys javanicus</i>	Bird	Lesser adjutant	Least Concern	Vulnerable	No	Operational	Human-wildlife conflict	High	Negligible	Very Low	Unlikely	Negligible	Negligible	Very Low	Unlikely	Negligible	
Faunal	Terrestrial	<i>Circus galgulus</i>	Bird	Blue-crowned night-heron	Least Concern	Vulnerable	No	Operational	Human-wildlife conflict	High	Negligible	Very Low	Unlikely	Negligible	Negligible	Very Low	Unlikely	Negligible	
Faunal	Terrestrial	<i>Numenius madagascariensis</i>	Bird	Bar eastern curlew	Endangered	Endangered	No	Operational	Human-wildlife conflict	High	Negligible	Very Low	Unlikely	Negligible	Negligible	Very Low	Unlikely	Negligible	
Faunal	Terrestrial	<i>Nycticorax nycticorax</i>	Bird	Black-crowned night heron	Least Concern	Endangered	No	Operational	Human-wildlife conflict	High	Negligible	Very Low	Unlikely	Negligible	Negligible	Very Low	Unlikely	Negligible	
Faunal	Terrestrial	<i>Ptilo megarhynchos</i>	Bird	Mangrove pitta	Near Threatened	Critically Endangered	No	Operational	Human-wildlife conflict	High	Negligible	Very Low	Unlikely	Negligible	Negligible	Very Low	Unlikely	Negligible	
Faunal	Terrestrial	<i>Puffinus longicauda</i>	Bird	Long-tailed parakeet	Vulnerable	Near Threatened	No	Operational	Human-wildlife conflict	High	Negligible	Very Low	Unlikely	Negligible	Negligible	Very Low	Unlikely	Negligible	
Faunal	Terrestrial	<i>Bubina fastata</i>	Bird	Red-legged crane	Least Concern	Near Threatened	No	Operational	Human-wildlife conflict	High	Negligible	Very Low	Unlikely	Negligible	Negligible	Very Low	Unlikely	Negligible	
Faunal	Terrestrial	<i>Splinteris cheela</i>	Bird	Crested serpent eagle	Least Concern	Critically Endangered	No	Operational	Human-wildlife conflict	High	Negligible	Very Low	Less likely	Negligible	Negligible	Very Low	Unlikely	Negligible	
Faunal	Terrestrial	<i>Sterna sumatrana</i>	Bird	Black-naped tern	Least Concern	Endangered	No	Operational	Human-wildlife conflict	High	Negligible	Very Low	Unlikely	Negligible	Negligible	Very Low	Unlikely	Negligible	
Faunal	Terrestrial	<i>Sterna albifrons</i>	Bird	Little tern	Least Concern	Endangered	No	Operational	Human-wildlife conflict	High	Negligible	Very Low	Unlikely	Negligible	Negligible	Very Low	Unlikely	Negligible	
Faunal	Terrestrial	<i>Trogon aurifer</i>	Bird	Northern's green hawk	Endangered	Endangered	No	Operational	Human-wildlife conflict	High	Negligible	Very Low	Unlikely	Negligible	Negligible	Very Low	Unlikely	Negligible	
Faunal	Terrestrial	<i>Anthracoceros albobitoris</i>	Bird	Oriental pied hornbill	Least Concern	Near Threatened	Yes	Operational	Human-wildlife conflict	High	Negligible	Very Low	Unlikely	Negligible	Low	Low	Unlikely	Negligible	
Faunal	Terrestrial	<i>Ardea cinerea</i>	Bird	Grey heron	Least Concern	Least Concern	Yes	Operational	Human-wildlife conflict	High	Negligible	Very Low	Unlikely	Negligible	Negligible	Very Low	Unlikely	Negligible	
Faunal	Terrestrial	<i>Ardea sumatrana</i>	Bird	Great-billed heron	Least Concern	Critically Endangered	Yes	Operational	Human-wildlife conflict	High	Negligible	Very Low	Unlikely	Negligible	Negligible	Very Low	Unlikely	Negligible	
Faunal	Terrestrial	<i>Corynorhinus melanotos</i>	Bird	White-rumped thimble	Least Concern	Endangered	Yes	Operational	Human-wildlife conflict	High	Negligible	Very Low	Unlikely	Negligible	Negligible	Very Low	Unlikely	Negligible	
Faunal	Terrestrial	<i>Copypicus saularis</i>	Bird	Oriental magpie-robin	Least Concern	Vulnerable	Yes	Operational	Human-wildlife conflict	High	Negligible	Very Low	Unlikely	Negligible	Negligible	Very Low	Unlikely	Negligible	
Faunal	Terrestrial	<i>Melanitta dipterygia</i>	Bird	Changeable hawk-eagle	Least Concern	Vulnerable	Yes	Operational	Human-wildlife conflict	High	Negligible	Very Low	Less likely	Negligible	Negligible	Very Low	Unlikely	Negligible	
Faunal	Terrestrial	<i>Pomastichus javanicus</i>	Bird	Skew-headed bulbul	Critically Endangered	Endangered	Yes	Operational	Human-wildlife conflict	High	Negligible	Very Low	Unlikely	Negligible	Negligible	Very Low	Unlikely	Negligible	
Faunal	Terrestrial	<i>Ariopala amphimuta amphimuta</i>	Butterfly	WA	Not Listed	Nationally Extinct (Rediscovered)	No	Operational	Human-wildlife conflict	High	Negligible	Very Low	Unlikely	Negligible	Negligible	Very Low	Unlikely	Negligible	
Faunal	Terrestrial	<i>Ariadne ariadne ariadne</i>	Butterfly	Angled castor	Not Listed	Nationally Extinct (Rediscovered)	No	Operational	Human-wildlife conflict	High	Negligible	Very Low	Unlikely	Negligible	Negligible	Very Low	Unlikely	Negligible	
Faunal	Terrestrial	<i>Aspilopterus jama jama</i>	Butterfly	Forest hopper	Not Listed	Nationally Extinct (Rediscovered)	No	Operational	Human-wildlife conflict	High	Negligible	Very Low	Unlikely	Negligible	Negligible	Very Low	Unlikely	Negligible	
Faunal	Terrestrial	<i>Bubo cinerascens</i>	Butterfly	Ersmoan swift	Not Listed	Endangered	No	Operational	Human-wildlife conflict	High	Negligible	Very Low	Unlikely	Negligible	Negligible	Very Low	Unlikely	Negligible	
Faunal	Terrestrial	<i>Calliope malaya</i>	Butterfly	Malayan swift	Not Listed	Nationally Extinct (Rediscovered)	No	Operational	Human-wildlife conflict	High	Negligible	Very Low	Unlikely	Negligible	Negligible	Very Low	Unlikely	Negligible	
Faunal	Terrestrial	<i>Catopyrops anaya</i>	Butterfly	Ancys blue	Not Listed	Vulnerable	No	Operational	Human-wildlife conflict	High	Negligible	Very Low	Unlikely	Negligible	Negligible	Very Low	Unlikely	Negligible	
Faunal	Terrestrial	<i>Coleonchilus amara amara</i>	Butterfly	White-banded flat	Not Listed	Nationally Extinct (Rediscovered)	No	Operational	Human-wildlife conflict	High	Negligible	Very Low	Unlikely	Negligible	Negligible	Very Low	Unlikely	Negligible	
Faunal	Terrestrial	<i>Ophreus acule niasicus</i>	Butterfly	Plain palm dart	Not Listed	Nationally Extinct (Rediscovered)	No	Operational	Human-wildlife conflict	High	Negligible	Very Low	Unlikely	Negligible	Negligible	Very Low	Unlikely	Negligible	
Faunal	Terrestrial	<i>Cethosia methyssea</i>	Butterfly	Plain lacewing	Not Listed	Critically Endangered	No	Operational	Human-wildlife conflict	High	Negligible	Very Low	Unlikely	Negligible	Negligible	Very Low	Unlikely	Negligible	
Faunal	Terrestrial	<i>Disophora sondaica desolata</i>	Butterfly	Common duffor	Not Listed	Critically Endangered	No	Operational	Human-wildlife conflict	High	Negligible	Very Low	Unlikely	Negligible	Negligible	Very Low	Unlikely	Negligible	
Faunal	Terrestrial	<i>Idia lucasae chersonesia</i>	Butterfly	Mangrove tree nymph	Not Listed	Critically Endangered	No	Operational	Human-wildlife conflict	High	Negligible	Very Low	Unlikely	Negligible	Negligible	Very Low	Unlikely	Negligible	
Faunal	Terrestrial	<i>Janides alecto agelada</i>	Butterfly	Melalici caeruleus	Not Listed	Nationally Extinct (Rediscovered)	No	Operational	Human-wildlife conflict	High	Negligible	Very Low	Unlikely	Negligible	Negligible	Very Low	Unlikely	Negligible	
Faunal	Terrestrial	<i>Naciduba karava nemana</i>	Butterfly	Transparent satirine blue	Not Listed	Nationally Extinct (Rediscovered)	No	Operational	Human-wildlife conflict	High	Negligible	Very Low	Unlikely	Negligible	Negligible	Very Low	Unlikely	Negligible	
Faunal	Terrestrial	<i>Naciduba pactulus odon</i>	Butterfly	Large fourline blue	Not Listed	Nationally Extinct (Rediscovered)	No	Operational	Human-wildlife conflict	High	Negligible	Very Low	Unlikely	Negligible	Negligible	Very Low	Unlikely	Negligible	
Faunal	Terrestrial	<i>Pachioptia aristolochiae astis</i>	Butterfly	Common rose	Not Listed	Vulnerable	No	Operational	Human-wildlife conflict	High	Negligible	Very Low	Unlikely	Negligible	Negligible	Very Low	Unlikely	Negligible	
Faunal	Terrestrial	<i>Pantimoia aspasia aspasia</i>	Butterfly	Yellow glassy tiger	Not Listed	Nationally Extinct (Rediscovered)	No	Operational	Human-wildlife conflict	High	Negligible	Very Low	Unlikely	Negligible	Negligible	Very Low	Unlikely	Negligible	
Faunal	Terrestrial	<i>Pantimoia vixeta tuberosa</i>	Butterfly	Handker	Not Listed	Nationally Extinct (Rediscovered)	No	Operational	Human-wildlife conflict	High	Negligible	Very Low	Unlikely	Negligible	Negligible	Very Low	Unlikely	Negligible	
Faunal	Terrestrial	<i>Panopsis sama sama</i>	Butterfly	Swamp swift	Not Listed	Nationally Extinct (Rediscovered)	No	Operational	Human-wildlife conflict	High	Negligible	Very Low	Unlikely	Negligible	Negligible	Very Low	Unlikely	Negligible	
Faunal	Terrestrial	<i>Potantinus trachala tyleri</i>	Butterfly	Detached dart	Not Listed	Nationally Extinct (Rediscovered)	No	Operational	Human-wildlife conflict	High	Negligible	Very Low	Unlikely	Negligible	Negligible	Very Low	Unlikely	Negligible	
Faunal	Terrestrial	<i>Rachana jallindra burtona</i>	Butterfly	Banded royal	Not Listed	Critically Endangered	No	Operational	Human-wildlife conflict	High	Negligible	Very Low	Unlikely	Negligible	Negligible	Very Low	Unlikely	Negligible	
Faunal	Terrestrial	<i>Saxilus everey everey</i>	Butterfly	White palm bob	Not Listed	Endangered	No	Operational	Human-wildlife conflict	High	Negligible	Very Low	Unlikely	Negligible	Negligible	Very Low	Unlikely	Negligible	
Faunal	Terrestrial	<i>Talicia color stinga</i>	Butterfly	Common palm dart	Not Listed	Nationally Extinct (Rediscovered)	No	Operational	Human-wildlife conflict	High	Negligible	Very Low	Unlikely	Negligible	Negligible	Very Low	Unlikely	Negligible	
Faunal	Terrestrial	<i>Troides helena reburus</i>	Butterfly	Common birdwing	Not Listed	Vulnerable	No	Operational	Human-wildlife conflict	High	Negligible	Very Low	Unlikely	Negligible	Negligible	Very Low	Unlikely	Negligible	
Faunal	Terrestrial	<i>Graphium doon everonides</i>	Butterfly	Common jay	Not Listed	Endangered	Yes	Operational	Human-wildlife conflict	High	Negligible	Very Low	Unlikely	Negligible	Negligible	Very Low	Unlikely	Negligible	
Faunal	Terrestrial	<i>Polyura moori moori</i>	Butterfly	Malayan nawab	Not Listed	Nationally Extinct (Rediscovered)	Yes	Operational	Human-wildlife conflict	High	Negligible	Very Low	Unlikely	Negligible	Negligible	Very Low	Unlikely	Negligible	
Faunal	Terrestrial	<i>Morionopon arhuri</i>	Damselfly	Arthur's midget	Near Threatened	Vulnerable	Yes	Operational	Human-wildlife conflict	High	Negligible	Very Low	Unlikely	Negligible	Negligible	Very Low	Unlikely	Negligible	
Faunal	Terrestrial	<i>Anis paryphus</i>	Dragonfly	Arrow emperor	Least Concern	Least Concern	No	Operational	Human-wildlife conflict	High	Negligible	Very Low	Unlikely	Negligible	Negligible	Very Low	Unlikely	Negligible	
Faunal	Terrestrial	<i>Oxyechon mosambicus</i>	Dragonfly	Common / Mosambican flagab	Vulnerable	Not Evaluated	No	Operational	Human-wildlife conflict	High	Negligible	Very Low	Unlikely	Negligible	Negligible	Very Low	Unlikely	Negligible	
Faunal	Terrestrial	<i>Comobita violaceus</i>	Hermit crab	Land hermit crab	Not Listed	Vulnerable	No	Operational	Human-wildlife conflict	High	Negligible	Very Low	Unlikely	Negligible	Negligible	Very Low	Unlikely	Negligible	
Faunal	Terrestrial	<i>Thalassia anomala</i>	Hermit crab	Red lobster	Not Listed	Endangered	No	Operational	Human-wildlife conflict	High	Negligible	Very Low	Unlikely	Negligible	Negligible	Very Low	Unlikely	Negligible	
Faunal	Terrestrial	<i>Thalassia gracilis</i>	Hermit crab	Mud lobster	Not Listed	Endangered	No	Operational	Human-wildlife conflict	High	Negligible	Very Low	Unlikely	Negligible	Negligible	Very Low	Unlikely	Negligible	
Faunal	Terrestrial	<i>Wormlebia phalaenalis</i>	Mud shrimp	NA	Not Listed	Endangered	No	Operational	Human-wildlife conflict	High	Negligible	Very Low	Unlikely	Negligible	Negligible	Very Low	Unlikely	Negligible	
Faunal	Terrestrial	<i>Melospiza fasciata</i>	Non-marine mammal	Long-billed macaque	Endangered	Least Concern	Yes	Operational	Human-wildlife conflict	High	Medium	Medium	Possible	Low	Low	Unlikely	Minor		
Faunal	Terrestrial	<i>Amey cinereus</i>	Non-marine mammal	Oriental small clawed otter	Vulnerable	Critically Endangered	Yes	Operational	Human-wildlife conflict	High	Medium	Medium	Unlikely	Negligible	Medium	Medium	Unlikely	Negligible	
Faunal	Terrestrial	<i>Hystrix brachyura</i>	Non-marine mammal	Malayan porcupine	Least Concern	Critically Endangered	No	Operational	Human-wildlife conflict	High	Low	Low	Unlikely	Negligible	Low	Low	Unlikely	Negligible	
Faunal	Terrestrial	<i>Manis javanica</i>	Non-marine mammal	Sunda pangolin	Critically Endangered	Critically Endangered	No	Operational	Human-wildlife conflict	High	Low	Low	Unlikely	Negligible	Low	Medium	Unlikely	Negligible	
Faunal	Terrestrial	<i>Lutrogale persipallata</i>	Non-marine mammal	Smooth otter	Vulnerable	Endangered	Yes	Operational	Human-wildlife conflict	High	Medium	Medium	Unlikely	Negligible	Medium	Low	Unlikely	Negligible	
Faunal	Terrestrial	<i>Prionailurus bengalensis</i>	Non-marine mammal	Leopard cat	Least Concern	Critically Endangered	Yes	Operational	Human-wildlife conflict	High	Low	Low	Unlikely	Negligible	Low	Low	Unlikely	Negligible	
Faunal	Terrestrial	<i>Tragulus napu</i>	Non-marine mammal	Greater mouse-deer	Least Concern	Critically Endangered	Yes	Operational	Human-wildlife conflict	High	Low	Low	Unlikely	Negligible	Low	Very Low	Unlikely	Negligible	
Faunal	Terrestrial	<i>Bogha cynodon</i>	Non-marine snake	Dog toothed cat snake	Least Concern	Vulnerable	No	Operational	Human-wildlife conflict	High	High	High	Less likely	Minor	Negligible	Very Low	Unlikely	Minor	
Faunal	Terrestrial	<i>Bogha melanota</i>	Non-marine snake	Gold-ringed cat snake	Least Concern	Vulnerable	No	Operational	Human-wildlife conflict	High	High	High	Less likely	Minor	Negligible	Very Low	Unlikely	Minor	
Faunal	Terrestrial	<i>Bungarus fasciatus</i>	Non-marine snake	Banded krait	Least Concern	Endangered	No	Operational	Human-wildlife conflict	High	Low	Low	Less likely	Minor	Negligible	Very Low	Unlikely	Minor	
Faunal	Terrestrial	<i>Daboia sibilans</i>	Non-marine snake	Keel-bellied whip snake	Least Concern	Endangered	No</												

Appendix I
Tree Protection and
Conservation
Guidelines)

METHOD STATEMENT FOR TREE PROTECTION AND CONSERVATION GUIDELINES

By

Derek Yap
Lead Arborist
Camphora Pte Ltd
ISA certified
SG-0117A

CONTENT REQUIREMENTS

This document outlines specific measures to protect trees during construction or other site disturbance. The content and scope of the document will vary based on the site, type of construction, tree species, tree location and other factors.

TREE PROTECTION AND CONSERVATION GUIDELINES

This section outlines the general provisions for tree protection before, during and after construction. Additional measures may be added by the attending arborist on a case-by-case basis.

PRE-DEMOLITION/PILING/CONSTRUCTION

1. Pre-Construction Meeting

The attending arborist shall attend a pre-construction meeting with the project contractor or construction supervisor to explain the tree protection and monitoring requirements as outlined in this document.

In addition, the project contractor or construction supervisor shall complete the 'VERIFICATION OF TREE PROTECTION CHECKLIST' as attached in Annex A before the onset of the construction.

1.1 Tree Protection Zone

Prior to any site clearing (demolition works), piling works, grading, trenching or other soil disturbance, a tree protection zone (TPZ) must be installed as follows:-

i. Type

The barriers should be temporary, made of a hard material, 1.8m tall and firmly installed into the ground.

ii. Ground protection

Mulching material (can be compost or woodchips) at 100mm thick to be laid within the TPZ in a doughnut formation. Mulching materials are to be kept 0.5m away from tree base. If woodchips are used, termicide treatment is necessary to prevent the introduction of harmful termites.

Apply complete fertilizer (N:P:K 15:15:15) upon or together with the application of mulch.

iii. Signage

A readily-visible and waterproof sign shall be installed on all sides of the fencing around each individual protected tree. The size of each sign must be a minimum of 300mm wide and must contain the wording below:

KEEP OUT!
TREE PROTECTION ZONE
Entry prohibited. This fence shall remain in place throughout the entire construction period.

iv. Fencing installation

Installation must be approved by the attending arborists and/or the approved authority prior to construction.

A diagrammatic representation of a proper Tree protection zone is presented below.

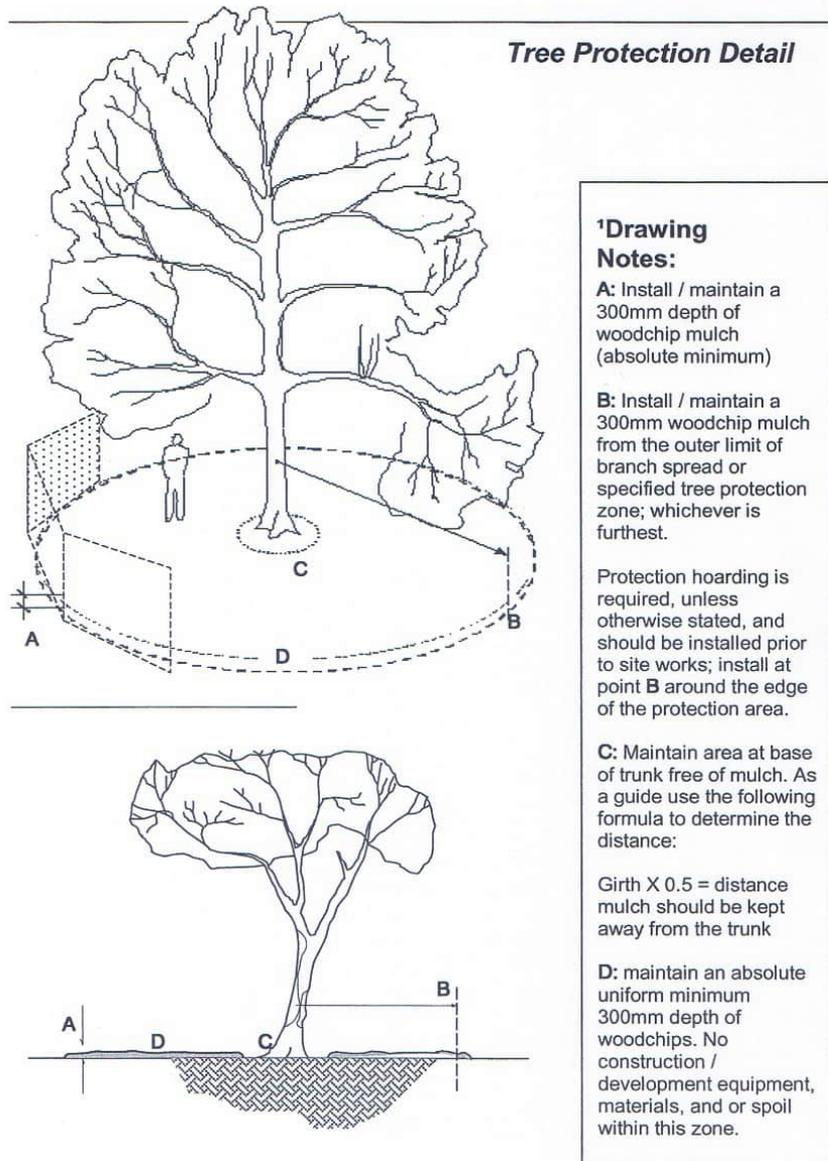

¹SEE NATIONAL PARKS BOARD TREE PROTECTION SPECIFICATION
- SITE CLEARANCE / DURING CONSTRUCTION

1.2 Tree pruning and removal

Various trees may need to be pruned away from structures or proposed construction activity. ***Construction or contractor personnel shall not attempt pruning.*** Only trained and competent personnel can perform pruning operations. See item 2.7 on engagement of arboriculture contractors. Consultation and written approval with attending arborist must be obtained prior to pruning.

Removal of trees adjacent to trees that are to be retained requires a great amount of finesse. Again only trained and competent arboriculture contractors as mentioned in item 2.7 shall engage in any tree removal.

Removal of trees that extend into branches or roots of protected trees shall not be attempted by the demolition or construction crew, or by grading or other heavy equipment. Before removing tree stumps, the project manager shall determine if roots are entangled with trees that are to remain. If so, these stumps shall have their roots severed before extracting them.

1.3 Site Clearance

To avoid lumber jack felling of trees that may severely damage the canopy of conserved trees, it is recommended that qualified (see Point 4.3 Tree Conservation Guidelines) Arboriculture contractors be engaged to fell trees adjacent to protected trees to ensure that the trees (when cut) fall away from the protected trees and their associated TPZs.

Contractors carry out tree felling works near assigned TPZs of conserved trees should

- i. Employ directional felling through the use of notch and back cuts
- ii. Deploy cranes to tension trunks in the direction of the drop
- iii. Carry out pruning of canopy branches to remove entangling branches
- iv. If trees to be removed are taller than neighbouring trees to be retained, removal of branches should be carried out in a controlled manner using ropes and cranes to avoid damaging canopy of the lower trees.
- v. To avoid pruning of conserved trees at the proximity unless consultation and approval from attending arborist has been obtained.

1.4 3D Scanning of trees in proximity to construction

- Prior to construction, identify trees that are for retention but are in proximity and may be affected by construction.
- 3D surveying affected trees and/or as specified by Client and its Consultants shall be carried out.
- The 3D tree scanning services shall be carried out in Survey 21 (“SVY 21”) datum and Singapore Height Datum (“SHD”).
- Processing of the 3D scan data include registration, geo-referencing and creation of 3D point cloud. The 3D point cloud data shall be in RCP format that is compatible with Revit. Surveyor has to assist with integrating the 3D point cloud model into the design plans in Revit format.
- 3D point cloud model shall include mapping of all visible structures of the tree canopy, trunks and roots to a resolution of 25mm.
- Each tree shall be prepared as individual point cloud file.



Figure 1: Surveyor to assist to integrate 3D point cloud model into Revit. 3D mapping to include mapping of all visible structures of the tree canopy, trunks and roots.

DURING DEMOLITION/PILING/CONSTRUCTION

2.1 Tree Protection Zone Restrictions

- No ground disturbance, grading, trenching or other construction activities shall occur within the TPZ except as specified and/or approved by the attending arborist or authority.
- No construction material, debris, machinery (e.g. generators) or other construction waste shall be stored within the TPZ. Weight and presence of these materials increases soil compaction and reduces the area exposed for water infiltration and gaseous exchange.



Figure 2: Construction material and heavy machinery are prohibited within the TPZ

- Excavation works within the TPZ are strictly prohibited. Unless otherwise specified by the attending arborist, all work done within the TPZ shall be completed with manual trenching with hand tools or other hand held power tools that will not cause any root/tree damage.

If roots need to be cut, it shall be done using proper equipment (e.g. pruning saw, chain saw) under the supervision of the attending arborist.



Figure 3: Trial trench by skilled workers using hand tools exposing root architecture

- Nailing, tying or pasting of materials on trees is prohibited. The tree shall not be used as an anchor for supporting structures during the construction.



Figure 4



Figure 5

Figure 3: Using tree as anchor may damage its bark

Figure 4: No nails shall be driven into the tree as it promotes infiltration of pests/diseases

- Phytotoxic materials such as fuels, oils, cement, chemicals, and paint shall be kept away and stored/mixed at least 2.5m from the tree protection zone. Such chemicals can significantly change the cation exchange capacity and pH of the soil, rendering nutrient uptake inefficient and creating an environment too toxic for the roots to grow.

Construction slug especially from piling works should not be deposited within the TPZ. Such sludge is usually high in clay content and when layered over and within the TPZ could significantly alter the water infiltration and gaseous exchange rates of the root absorption area of the tree.

Canvass sheets/Eco-mat must be laid on the existing soil near the tree in view of soil protection during the demolition, drilling or other construction activities pertaining to concrete structures.



Figure 6: Construction cement deposited at tree base



Figure 7: Tree showing signs of decline overtime

- Lowering the grade around trees can have an immediate and long-term effect on trees. Typically, most roots are within the top 1m of soil, and most of the fine roots active in water and nutrient absorption are in the top 300mm.

A) Grade changes within the TPZ are not permitted.

B) Grade changes outside the TPZ shall not significantly alter drainage.

C) Grade changes under specifically approved circumstances shall not allow more than 200mm of fill soil or allow more than 150mm of existing soil to be removed from natural grade, unless mitigated.

D) Grade fills over 200mm or impervious overlay shall incorporate an approved permanent aeration system, permeable material, or other approved mitigation.

E) Grade cuts exceeding 150mm shall incorporate retaining walls or an appropriate transition equivalent.

No removal of the TPZ will be permitted under any circumstances.



Figure 8: Inappropriate installation/maintenance of TPZ during construction

2.2 Proximity of Heavy Machinery/vehicles

Heavy vehicles and machinery (e.g. excavators, piling cranes, 10 wheelers) movement should be limited near TPZs. Temporary access/passageways should be planned to avoid conserved trees.



Figure 9: Tree branches were severed due to the negligence of the crane operator

2.3 Drainage Considerations

In the event that water ponding conditions develop in the course of construction due to change in grade/platform levels, construction events or any other unforeseeable factors, the contractor is required to improve drainage around or within the TPZ in consultation with the attending arborist.

2.4 Trenching, Excavation and Equipment use

Trenching, excavation or boring within the TPZ shall be limited to activities approved by the architect and/or attending Arborist. Explore alternatives for trenching outside the root zone. Avoid exposing roots during hot, dry weather. Backfill trenches as soon as possible with soil and soak with water the same day. Small roots can die in 10 to 15 minutes and large roots may not survive an hour of exposure. If the trench must be left open all roots must be kept moist by wrapping them in peat moss and burlap.

i. Root Severance

No roots greater than 0.2m in diameter shall be cut without approval of the attending Arborist. Tunneling under roots is the approved alternative. Prior to excavation for foundation/footing/walls, or grading or trenching within the TPZ, roots shall be severed cleanly outside the TPZ to the depth of the planned excavation. When roots must be cut, they shall be cut cleanly with a sharp saw to sound wood and flush with the trench site.

Exposed roots wrapped with burlap (also known as gunny sack)



Figure 10: Tunneling under roots

ii. Excavation

Any approved excavation, demolition, or extraction of material shall be performed with equipment that is placed outside the TPZ. Hand digging, hydraulic, or pneumatic excavation (e.g. air spading) are permitted methods for excavation within the TPZ.



Root exploratory works using an air spade. Air spading avoids damage of structural and even feeder roots of the tree.

iii. Heavy Equipment

Use of backhoes, Ditch-Witches, steel tread tractors or other heavy vehicles within the TPZ is prohibited unless approved by the attending Arborist. If allowed, a protective root buffer is required.

2.5 Tree Care

In the course of construction, the following measures may be necessary to reduce the effects of construction stress on protected trees. Quantum, duration and extent to be advised by attending arborist.

(A) Fertilization

A1 Vertical trenches and Nutrient Sinks

Create vertical trenching and nutrient sinks. These nutrient sinks should go down to at least 300mm deep and should be filled with high grade compost and 12% Humic acid (dilution 1:100). These sinks will act to reduce construction stress by conditioning the soil, increasing soil microbiological activity and increasing organic matter. At least 24 numbers of vertical trenches / nutrient sinks are required for trees greater than 2m in girth. Vertical trenches for trees under 2m in girth will be determined empirically by the attending arborist and will take into account site conditions, tree species and its pre construction vigor. Top up nutrient sinks every 3 months.

A2 Soil Injection of Biostimulants

Mandatory if TPZ has been infringed into, soil compaction has occurred, tree condition has observed to have declined (indicators: reduction in Live crown ratios, twig die back at canopy and change in leaf colour/size/density)

- **Purpose :** To de-compact soil using a hydraulic pressurized delivery of biostimulants that both hydrates and aerates at the same time. Aim to reduce compaction to less than 400psi in the first 500mm of the soil.

- Mixed bio stimulants – serves 2 functions

Decompaction

- Humic acid – as soil conditioner and chelating agent (Nutrients are mobilized in forms that the plants can accept), facilitate release of nutrients and reduces leaching. Also improves water holding capacities of soil.
- Liquid gypsum / Dolomite – soil conditioner, improve soil structure and facilitate release of nutrients in clay soils typical of local conditions.

To feed and increase soil microbiology to increase tree vigor post damage. Soil microbiology helps nutrient uptake and encourages healthy root growth critical to prevent construction stress.

- Mollases – High CE for immediate uptake,
- Fish Kelp – Protein source. Organic fertilisers
- Slow release fertilizers (Osmocote)

(B) Watering

- Water supplement during periods of drought.
- Watering duration and extent depends on site conditions and species.
- Watering is carried out until first signs of inundation are observed (i.e. water infiltration observe to slow down significantly).

(C) Myconate treatment

- To trigger and stimulate growth of existing mycorrhizae.

(D) Pesticide treatment

- To control pest (e.g. termites, borers, caterpillars etc) when it occurs.
- Fungicide or bactericide as required or as determined by attending arborist to control microbe pathogens.

(E) Additonal pruning

To be carried out in consultation with the attending Arborist. Trees are living things and may require some form of pruning during the course of the development.

- Crown cleansing- Prune to remove dead branches and parasitic plants that may have developed through time.
- Crown lifting- Prune to lift crown to avoid new amenities.
- Crown thinning- Prune to reduce canopy branches and loading.

Structural pruning (including crown reduction) to remove branches that may obstruct new amenities and/or movement of critically necessary equipment may require the planning and standing supervision of the attending arborist.

2.6 Infringement

Instilling discipline and awareness amongst workers and crane/excavator operators is key to reducing damage to protected trees during the course. Contractors should include reminders of tree conservation guidelines within their daily briefings to their workers and crane/excavator operators.

To instill site discipline and discourage unnecessary damages to trees, the following fines will be implemented in event of damage to trees due to negligence.

Contractor should also note that they will become fully liable for the full amount of any fines imposed by NParks in event of unauthorized damage to trees within the Tree Conservation Area.

Damage to Roots

Root Size	Fine Amount per event
<0.2m girth	\$500
0.2-0.5m girth	\$1000
0.5-0.8m girth	\$1500
>0.8m girth	\$2000

Damage to Branches

Branch Size	Fine Amount per event
<0.5m girth	\$500
0.5-0.8m girth	\$800
0.8-1.0m girth	\$1200
>1.0m girth	\$2000

Damage to Trunk

Trunk Size	Fine Amount per event
<0.5m girth	\$300
0.5-1.0m girth	\$600
1.0-1.5m girth	\$900
1.5-2.0m girth	\$1200
>2.0m girth	\$1500

Removal of TPZ without prior written approval from architect or attending arborist.

S\$5000/event

2.7 Engaging Arboriculture Contractors

All arboriculture works shall be carried out by skilled and trained arboriculture teams. Only trained and skilled personnel who meet NParks' and MOM's safety requirement for work at height, handling of machinery, equipment and vehicles shall carry out arboriculture operations. Arboriculture contractors shall also meet LTA's requirements for temporary works along roadsides (where necessary) and have an ISA certified arborist to supervise the pruning/felling/planting works. As such, it is preferred that only arboriculture contractors which have at least three years contract experience with NParks be engage for tree works for the development.

Three Arboriculture contractors who have contract experience with NParks are listed below for reference.

Soh & Tan Enterprises Pte Ltd
Blk 136 Petir Road #01-352
Singapore 670136
Tel: 6227 6638
HP: 90064349
Fax: 6763 2126

Mao Sheng QuanJi Landscaping Pte Ltd
371 Upper Paya Lebar Road
#01-02 Yi Kai Court S534969
Tel: 9756 5675 (Mr Xia)
Fax: 6285 2731

AJ Horticultural Services
11 Jalan Basong
Singapore 759446
TEL: 9069 7277 (Johnny)
FAX: 6759 9832

POST-CONSTRUCTION

3. Soft Landscaping

Ground works, site preparation and implementation of all landscaping near protected trees must be undertaken carefully.

TPZ barriers can only be removed at this juncture for the purpose. However, when working near trees, cultivation of soils in these areas must be cautiously handled using hand tools. Planting of shrubs shall be at a distance of at least 300mm away from existing root collar.

Avoid changes to ground levels or unnecessary compaction of soils within proximity to existing trees during the course.



Figure 11: New plantings at a minimum distance of 300mm (all round) from root collar

ANNEX A

VERIFICATION OF TREE PROTECTION CHECKLIST

Note: The project contractor or construction supervisor shall verify in writing that all **preconstruction** tree preservation conditions have been met as follows:

Submitted by: _____

Company/Project: _____

Date/Time: _____

S/N	Action	Checked (✓)	Remarks
1	Installation of tree fencing around identified trees within/near site (hard material at 1.8m tall)		
2	Tree protection zone (TPZ) dimensions meets specifications (from NParks and/or attending arborist)		
3	Warning signs prominently displayed on all sides of the fencing, including designated tree number		
4	Removal of construction material (ie machinery, debris, tools etc) within TPZ		
5	Mulching of high grade compost of 100mm thick around identified trees		
6	Completion of tree pruning (if necessary) under the supervision/written approval with the attending arborist		
7	Establishment of a tree maintenance schedule according to arborist recommendations (to be submitted to attending arborist)		

Verified by (attending arborist): _____

Date/Time: _____

LETTER OF ACKNOWLEDGEMENT

I, _____ (Name) of _____ (Company)
hereby acknowledge the receipt of this document and have clearly read the guidelines
stated by CAMPHORA PTE LTD.

Accepted and agreed:-

The client:

Attending arborist:

Signature/Company Stamp

Derek Yap, Lead Arborist
CAMPHORA PTE LTD

Date

Date

LETTER OF ACKNOWLEDGEMENT

I, _____ (Name) of _____ (Company)
hereby acknowledge the receipt of this document and have clearly read the guidelines
stated by CAMPHORA PTE LTD.

Accepted and agreed:-

The client:

Attending arborist:

Signature/Company Stamp

Derek Yap, Lead Arborist
CAMPHORA PTE LTD

Date

Date

Appendix J
Fauna Inspection Form

Appendix K
Pre-felling Inspection
Form

Appendix L
Wildlife Incident Form

Wildlife Incident Form

Date (YYYY/MM/DD):	Time:
Description of Location:	GPS Coordinates:
Wildlife Observed:	Animal Condition (circle): Alive / Killed / Dead / Injured Animal activity (circle): Moving / Resting / Trapped
Photographs Taken:	MFLG and NParks notified: Yes / No Name of staff notified:
Describe Incident (e.g., activities being carried out; what animal was doing; personnel involved):	
Actions Taken:	
Reported by:	Reported to:
Contact no.:	Contact no:
Remarks:	

Appendix M
Marine Water Impact
Assessment Criteria

Appendix M Marine Water Impact Assessment Criteria

Impact assessment criteria are summarized in this section, which were either adapted from published guidelines (e.g. Biodiversity Impact Assessment (BIA) Guidelines published by NParks, ASEAN Marine Water Quality Guidelines, etc.), or developed based on scientific literature reviews.

M.1 Hydrodynamics

Impacts on hydrodynamics from the proposed development have been evaluated with based on analysis of maximum (95th percentile) marine current speed.

As regulated by Maritime and Port Authority of Singapore (MPA), a vessel navigating in the East Johore Strait cannot exceed the speed limit of 12 knots (i.e. 6.17 m/s), while a vessel navigating in a river cannot exceed the speed limit of 5 knots (i.e. 2.57 m/s). Compared with vessel speed, increase in maximum current speed of less than 0.1 m/s, which can be less than 10% of vessel speed, can be considered as “Negligible”. If current speed is reduced, it may not pose negative impacts on vessel navigation.

M.2 Morphology

Morphological changes in the seabed may occur due to construction of the headlands and beach nourishment activities during construction phase, as well as potential changes in hydrodynamics during operational phase. The purpose of morphological impact assessment is to study the long-term effects of the proposed development on the seabed morphology, which depends heavily on the seabed properties (e.g. particle size distributions, density, sediment quality, etc) and suspended sediment properties.

In terms of impact on sediment quality, as mentioned in the main report, various sediment quality standards have been used to compare with the sediment survey data. These guidelines include Singapore General guidelines for Dredging / Dumping Works, Florida Department of Environmental Protection and Ontario Guidelines for the Protection and Management of Aquatic Sediment Quality.

Besides sediment quality, potential erosion or sedimentation status have been predicted through the morphological modelling to assess long-term morphological impact from the proposed development.

M.3 Marine Water Quality

Impact on marine water quality is based on the NEA's trade effluent water quality requirements for uncontrolled watercourse as well as criteria stated in the Biodiversity Impact Assessment (BIA) Guidelines published by NParks. In addition, ASEAN Marine Water Quality Guideline has also been referred during the impact assessment of this Study.

M.4 Ecology and Biodiversity

Seagrass

NParks' BIA has also established tolerance limits for seagrass. Tolerance limits related to seagrass receptors including its tolerance to suspended sediment and sedimentation as listed below.

Table M - 1 Suspended sediment thresholds for seagrass in Singapore

Severity	Seagrass
No Impact	Excess SSC > 5 mg/L for less than 20% of the time
Slight Impact	Excess SSC > 5 mg/L for more than 20% of the time Excess SSC > 10 mg/L for less than 20% of the time
Minor Impact	Excess SSC > 25 mg/L for less than 5% of the time
Moderate Impact	Excess SSC > 25 mg/L for more than 20% of the time

Severity	Seagrass
	Excess SSC > 75 mg/L for more than 1% of the time
Major Impact	Excess SSC > 75 mg/L for more than 20% of the time

Table M - 2 Sedimentation thresholds for seagrass in Singapore

Severity	Seagrass
No Impact	Sedimentation < 0.1 kg/m ² /day (< 0.25 mm/day)
Slight Impact	Sedimentation < 0.25 kg/m ² /day (< 0.63 mm/day)
Minor Impact	Sedimentation < 0.5 kg/m ² /day (< 1.25 mm/day)
Moderate Impact	Sedimentation < 1.0 kg/m ² /day (< 2.5 mm/day)
Major Impact	Sedimentation > 1.0 kg/m ² /day (> 2.5 mm/day)

As per the BIA Guideline, No Impact to minor impacts are defined as acceptable impact levels in a given environmental receptor.

Mangrove

Tolerance limits related to mangrove receptors include its tolerance to suspended sediments and sedimentation.

Mangrove tolerance to suspended sediments

As mentioned in Furukawa and Wolanski's study, the sediment particles carried in suspension into the forest during tidal inundation will form large flocs, which remain in suspension as a result of the turbulence created by flow around the vegetation. Such flocs settle in the forest around slack high tide. During ebb tides the water currents are too small to re-entrain this sediment. Hence the inundation of coastal mangrove forests at tidal frequency works as a pump preferentially transporting sediment from coastal waters to the mangroves. Mangroves are thus not just opportunistic tree colonising mud banks but actively contribute to the creation of mud banks.

Therefore, mangroves can be considered fully tolerant to the range of suspended sediment concentration which may be induced by the construction activities. This is also aligned with the conclusion from a previous report from Doorn-Groen (2007).

Mangrove tolerance to sedimentation

While mangroves thrive on accreting shoreline, excess sediment deposition (i.e. sedimentation) could cause negative impact on mangroves, such as reducing seedling establishment, altering plant physiology, reducing tree growth, increasing tree mortality, etc. With the excess sediment deposition, the survival and growth of mangrove seedling could be limited with low oxygen in the root zone. Ellison (1998) concluded that mangroves naturally accrete at rates of < 0.5 cm/year (0.014 mm/day), with a maximum around 1 cm/year (0.027 mm/day), taking average of studies done at various mangroves. Sediment burial in mangrove environments is therefore defined as sedimentation in excess of these rates, related to a disturbance. However, it should be noted that the tolerance of mangrove will differ from species to species. Sidik et. al. (2016) suggests that the growth of genus *Avicennia* could cease at sedimentation rate of 1.16 mm/day (equivalent to 40 cm/year), while Ellison (1998) suggests some species (e.g. *Rhizophora apiculata*, *Avicennia marina*, etc.) could show death when sediment increases by about 32-100cm. Hence, the effects on mangroves of root burial are summarised as below:

- No adverse effects (no/negligible impact): short-term natural sedimentation rates in mangrove swamps ≤ 0.03 mm/day (mangroves thrive on sedimentary shoreline)
- Stressed (minor impact): sediment burial on mangroves > 0.03 mm/day
- Cease of growth or even death (moderate to major impact): sediment burial on mangroves > 1.16 mm/day

M.5 Socio-Economic

Tolerance limits under the category of socio-economic impact for this study include:

- Aquaculture farm
- International Boundary (IB) / Visual impact

Aquaculture farm

Singapore's Marine Water Quality Guidelines for aquaculture has been developed based on locally-farmed marine food fish in net cages at about 3 – 4 metres deep. With an understanding that turbidity and total suspended solids are often location specific and can be affected by seasonal variations, the guideline stipulates that both parameters should be kept to a $\leq 10\%$ increase from background median.

According to the ASEAN Marine Water Quality Criteria, for aquatic life protection, the maximum permissible limit for total suspended solids is a 10% increase over the seasonal average concentration.

Philippines Revised Effluent Regulations of 1990 stated that for spawning areas and commercial/sustenance fishing areas should not exceed an increase of 30 mg/L from background levels.

Manitoba Department of Environment suggests that the maximum acceptable concentration for nonfilterable residue is 25 mg/L.

Lloyd (1985) concluded that an increase in turbidity of 25 NTU in shallow, clearwater systems may potentially reduce stream primary productivity by 13-50% or more, and be associated with an increase in suspended sediment concentration of approximately 25 – 100 mg/L. A 5 NTU increase in turbidity in clear water systems may reduce the primary productivity by 3 – 13% or more and be associated with an increase in suspended sediment concentration of approximately 5 – 25 mg/L.

In 2015, Kjelland et. al. provided a review on most of previous studies on the SSC impacts on various aquatic life. It mentioned when the total SSC reaches 100 mg/L (equivalent to Excess SSC of around 50 mg/L when our baseline data were below 50 mg/L), physiological stress was reported for all life stages of two species, i.e. spotfin chub (*Erimonax monachus*) and whitetail shiner. When total SSC reaches 250 mg/L (equivalent to Excess SSC of around 200 mg/L in our case), the self-aggregation of the eggs could lead to both lethal and sublethal impacts. When total SSC reaches 300 mg/L to 300 g/L, it can cause mortality of various aquatic species.

Based on literature review as above, the suspended sediment thresholds for aquaculture farm were listed in Table M - 3.

Table M - 3 Suspended sediment thresholds for aquaculture farm

Severity	Aquaculture farm
No Impact	Excess SSC < 5 mg/L for 95% of the time
Slight Impact	5 mg/L < Excess SSC < 10 mg/L for 95% of the time
Minor Impact	10 mg/L < Excess SSC < 25 mg/L for 95% of the time
Moderate Impact	25 mg/L < Excess SSC < 200 mg/L for 95% of the time
Major Impact	Excess SSC > 200 mg/L for 95% of the time

International boundary (IB) / Visual Impact

As per the ASEAN Marine Water Quality Guideline, suspended sediment concentration (SSC) is allowed to have 10% maximum increase over seasonal average concentration for all the time, which was estimated as 2.6 mg/L in the East Johor Strait based on annual mean suspended sediment concentration measured in previous study (Palani and Tklich, 2014). And the range of SSC can be from 2.8 mg/L to 57.3 mg/L in East Johor Strait (Gin et al. 2000). Besides, Doorn-Groen (2007) concluded 5 mg/L changes in SSC is not visible in the turbid environments

that are found around Singapore. Hence, the SSC thresholds for IB/Visual Impacts in the East Johor Straits were proposed as below based on analysis on baseline data as well as historical SSC data:

Table M - 4 Suspended sediment thresholds for IB/visual impact

Severity	Visual Impact
No Impact	Excess SSC < 2.6 mg/L for all the time
Slight Impact	Excess SSC < 5 mg/L for 95% of the time
Minor Impact	Excess SSC > 5 mg/L for more than 5% of the time Excess SSC < 25 mg/L for 99% of the time
Moderate to Major Impact	Excess SSC > 25 mg/L for more than 1% of the time

M.6 Reference

Association of Southeast Asian Nations (ASEAN). ASEAN Marine Water Quality Management Guidelines and Monitoring Manual. 2008. <https://environment.asean.org/wp-content/uploads/2015/07/ASEAN-MarineWaterQualityManagementGuidelinesandMonitoringManual.pdf>

Department of Environment and Natural Resources, DENR Administrative Order No. 34 (Series of 1990)1–16 (1990).

Doorn-Groen, Stéphanie. (2007). Environmental monitoring and management of reclamations works close to sensitive habitats. Terra et Aqua.

Ellison JC (1998) Impacts of Sediment Burial on Mangroves. Marine Pollution Bulletin. Vol 37, Nos 8-12, pp420-426.

Ellison, Joanna. (1999). Impacts of Sediment Burial on Mangroves. Marine Pollution Bulletin. 37. 420-426. 10.1016/S0025-326X(98)00122-2.

Furukawa, Keita & Wolanski, Eric & Mueller, H. (1997). Currents and Sediment Transport in Mangrove Forests. Estuarine, Coastal and Shelf Science. 44. 301-310. 10.1006/ecss.1996.0120.

Frida Sidik, David Neil and Catherine E. Lovelock (2016). Effect of high sedimentation rates on surface sediment dynamics and mangrove growth in the Porong River, Indonesia. Marine Pollution Bulletin 107 (2016) 355-363.

Gin, KYH, Lin, XH, Zhang, S (2000). Dynamics and size structure of phytoplankton in the coastal waters of Singapore. Journal of Plankton Research. Vol 22, Issue 8, pp 1465-1484.

Kerr, SJ (1995) Silt, turbidity and suspended sediments in the aquatic environment: an annotated bibliography and literature review. Ontario Ministry of Natural Resources, Southern Region Science & Technology Transfer Unit Technical Report TR-008. 277 pp.

Maritime and Port Authority of Singapore (2000), Maritime and Port Authority of Singapore (Port) Regulations, <https://sso.agc.gov.sg/SL/MPASA1996-RG7>

Michael E. Kjelland, Christa M. Woodley, Todd M. Swannack, David L. Smith (2015), A review of the potential effects of suspended sediment on fishes: potential dredging-related physiological, behavioural, and transgenerational implications. Environment Systems and Decisions 35, 334-350.

National Park Board, Singapore (no date) Biodiversity Impact Assessment (BIA) Guidelines.

Palani and Tklich, 2014, Water Quality Modelling in the East Johor and Singapore Straits. Journal of Water Pollution and Treatment: Vol 2014, pp 36-49

S Bryce, P Larcombe, P.V Ridd,(2003) Hydrodynamic and geomorphological controls on suspended sediment transport in mangrove creek systems, a case study: Cocoa Creek, Townsville, Australia. Estuarine, Coastal and Shelf Science. Vol 56, Issues 3–4, pp 415-431

Technical Committee on Coastal and Marine Environment (TCCME). Technical Information on Singapore's Marine Water Quality Guidelines (MWQG).

Williamson, DA (1983) Surface water quality management proposal, Volume 1: Surface water quality objectives. Water Standards and Studies Report No. 83-2, Manitoba Department of Environment and Workplace Safety and Health, Winnipeg, Manitoba.

Appendix N
Marine Water Model
Setup and Calibration

Appendix N Marine Water Model Setup and Calibration

The section provides the details of the modelling parameters as applied during the EIS for mangrove restoration of Sungei Durian Ponds in Pulau Ubin. The following models undertaken for the EIS are described in detail in order to simulate the hydrodynamic, morphology and sediment plume.

N.1 Hydrodynamic Modelling (Delft3D)

Model Description

In this study, a hydrodynamic model (Delft3D) was used in which flow structures and the dispersion, dilution and accumulation patterns of pollutants, as transported by the current circulation, simulated under different tidal conditions of Johor Strait. Delft3D is a fully integrated computer suite for a multi-disciplinary approach and 3D computations for coastal, river and estuarine areas.

The model simulates multi-dimensional hydrodynamic and transport processes and calculates non-steady flow and transport phenomena that result from tidal and meteorological forcing on a curvilinear, boundary fitted grid.

The Delft3D hydrodynamic model includes the following standard features:

- Tidal forcing;
- The effect of the Earth's rotation (Coriolis force);
- Density driven flows (pressure gradients terms in the momentum equations);
- Advection-diffusion solver included to compute density gradients with an optional facility to treat very sharp gradients in the vertical;
- Space and time varying wind and atmospheric pressure;
- Advanced turbulence models to account for the vertical turbulent viscosity and diffusivity based on the eddy viscosity concept;
- Time varying sources and sinks (e.g. tributary discharges);
- Simulation of the brine discharge and the intake of water at three proposed locations;
- Drogue tracks; and
- Robust simulation of sediment plume and morphological changes.

Model Domain

The hydrodynamic model was developed using curvilinear grid to be able to reflect curvilinear flow surrounding Pulau Ubin. The model domain of Project Site covers the Ponds (Figure N - 1). The model grid size ranged from 2 – 200 m. The surveyed hydrographic data provided by client as well as Singapore Navigation Chart were used to interpolate model bathymetry as shown in Figure N - 2. All water depths were reduced to Mean Sea Level (MSL).

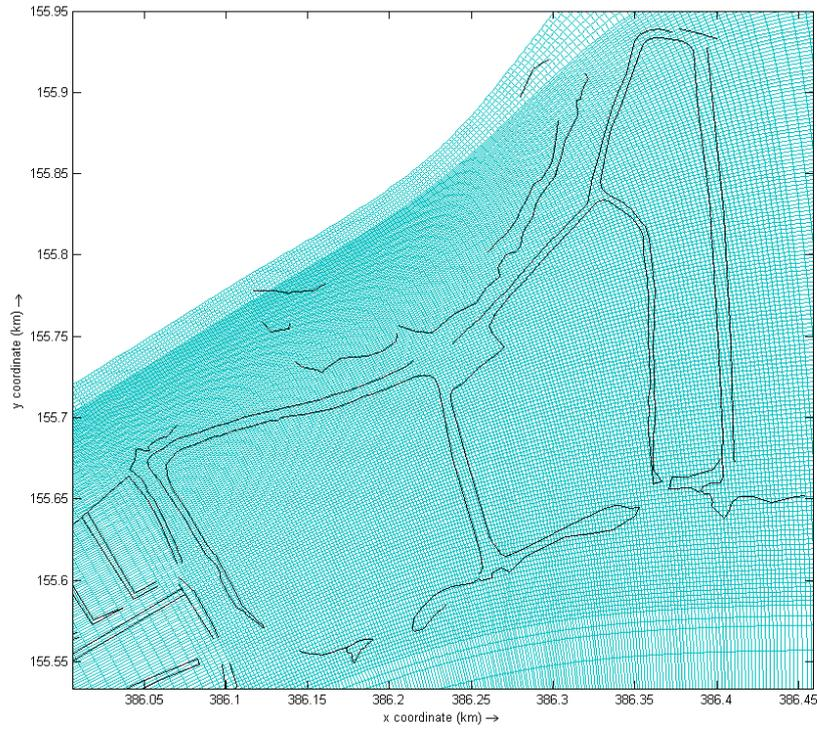

Figure N - 1 Model domain of the Project Site with resolution of 2 m at the area of interest.

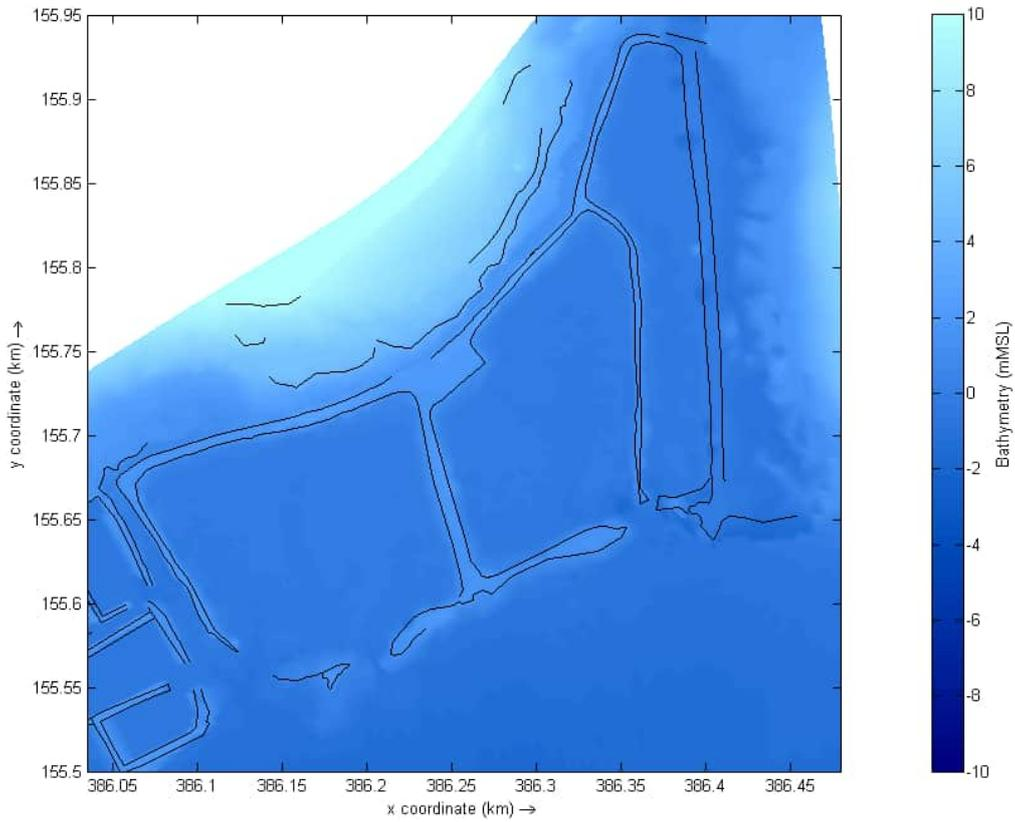

Figure N - 2 Bathymetry of the Project Site.

Simulation Periods

A period of 14 days was simulated for the hydrodynamic modelling studies to represent a full tidal cycle during both Northeast and Southwest Monsoon seasons. The 14-day period was selected for highest measured water level occurring during a year, which represent a conservative assessment for the EIS as the strong tide promotes higher currents that potentially bring contaminants to the identified receptors.

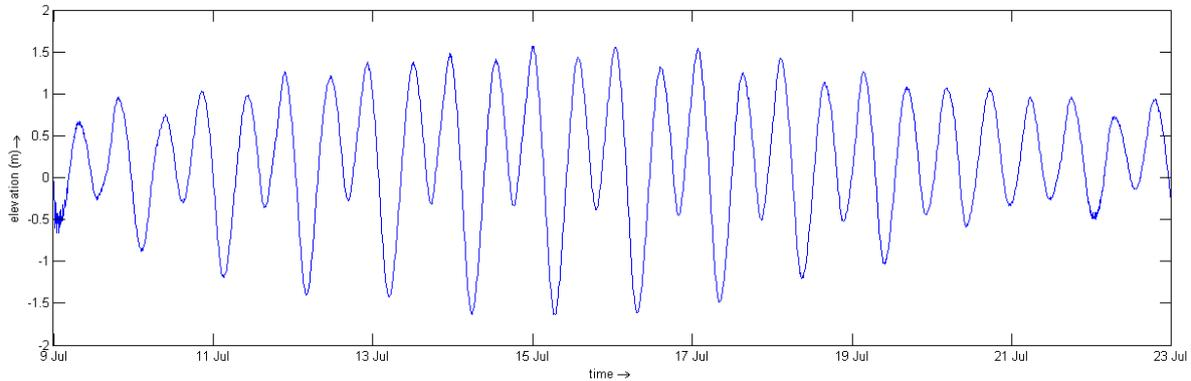

Figure N - 3 Typical water level in hydrodynamic simulation.

Boundary Conditions

The boundary conditions of current local hydrodynamic model used for EIS were generated from regional model which covers the whole East Johor Straits (EJS).

Model Parameters

The Delft3D model parameters for the hydrodynamic models are summarised in the table blow. Unless stated, default parameters were used.

Table N - 1 Model input parameters

Model	Input Parameters
Grid Resolution	2 – 200 m
Time Step	1 min
Horizontal eddy viscosity	0.28
Horizontal eddy diffusivity	1
Bed roughness	Varying in domain

Model Calibration

The hydrodynamic model was calibrated to align with the measured data (i.e. current regime and tidal level) so that the performance of the model is verified. Generally, to evaluate whether the model provides acceptable accuracy, following criteria are considered based on the UK Foundation for Water Research publication Ref FR0374 – “A Framework for Marine and Estuarine Model Specification in the UK”.

- Tidal level: Root Mean Square Error (RMSE) < $\pm 0.1\text{m}$ or 10% of the measured level during spring tide and $\pm 15\%$ during neap tide;
- Current speed: RMSE < $\pm 0.1\text{m/s}$ or $\pm 10\%$ to 20% of the measured speed is considered as good, < $\pm 0.2\text{m/s}$ is considered moderate; and

The model calibration was done by comparing model results to measured data provided by Housing Development Board (HDB) on 17th October 2018, and the location of the point (i.e. S13) used for calibration is shown in Figure N - 4.

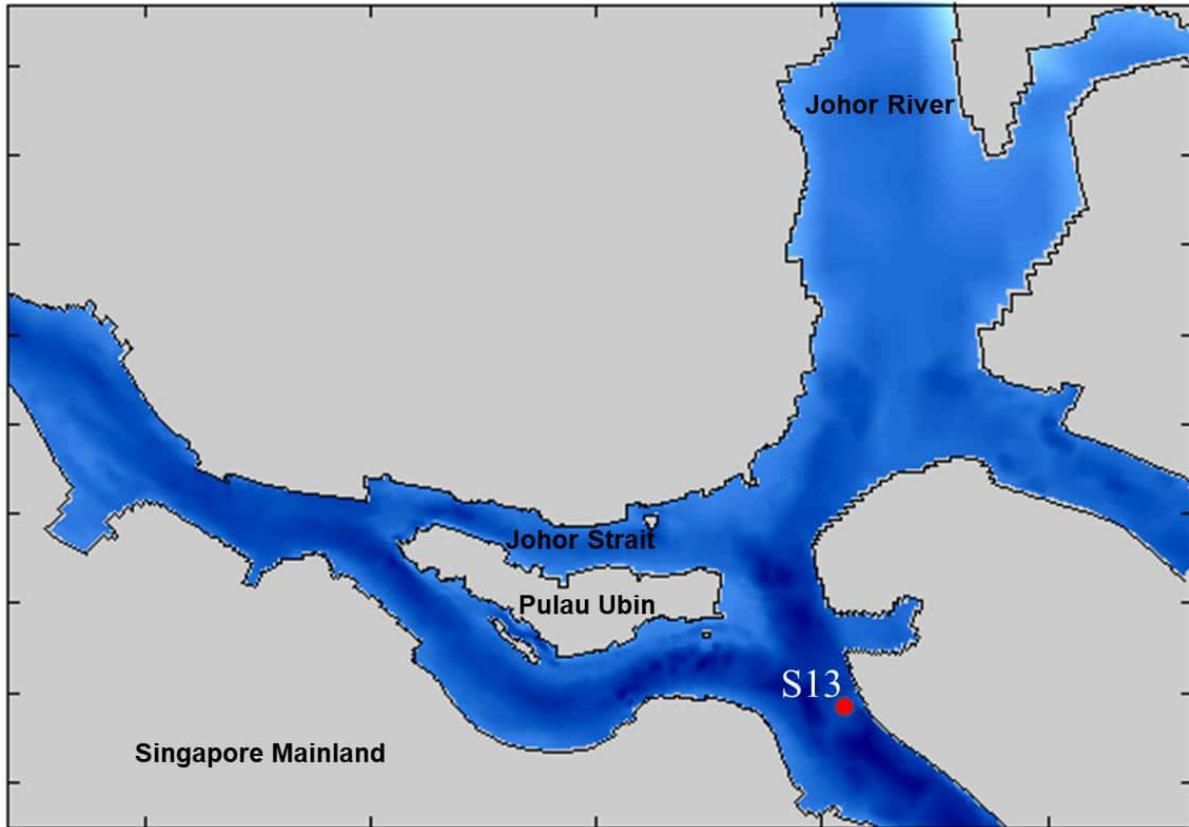

Figure N - 4 Calibration point (S13).

The calibration results show that the model is generally robust and was able to reproduce the flow characteristics for the calibration period from 9th July 2018 to 21st July 2018 (Figure N - 5 and Figure N - 6, Table N - 2).

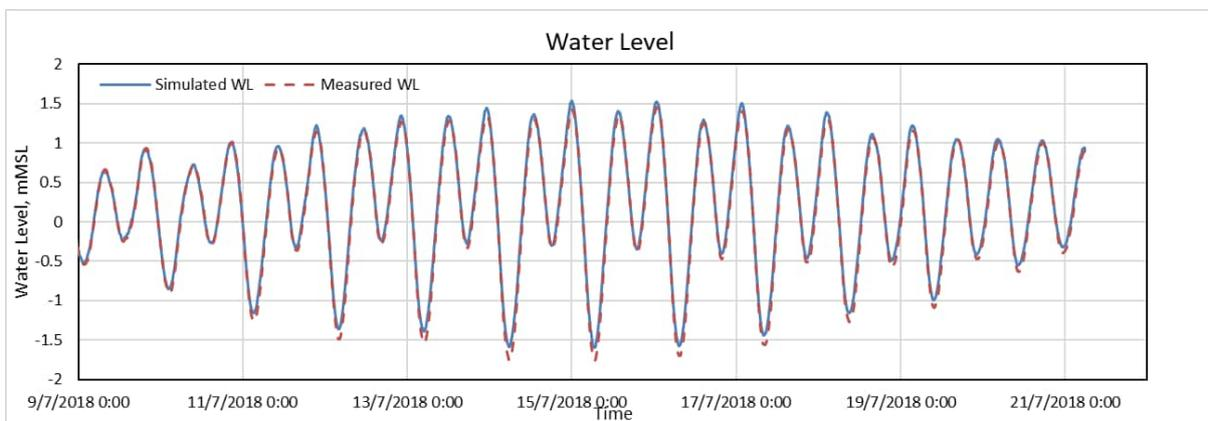

Figure N - 5 Comparison of water levels between simulated and measured data for one full tidal cycle.

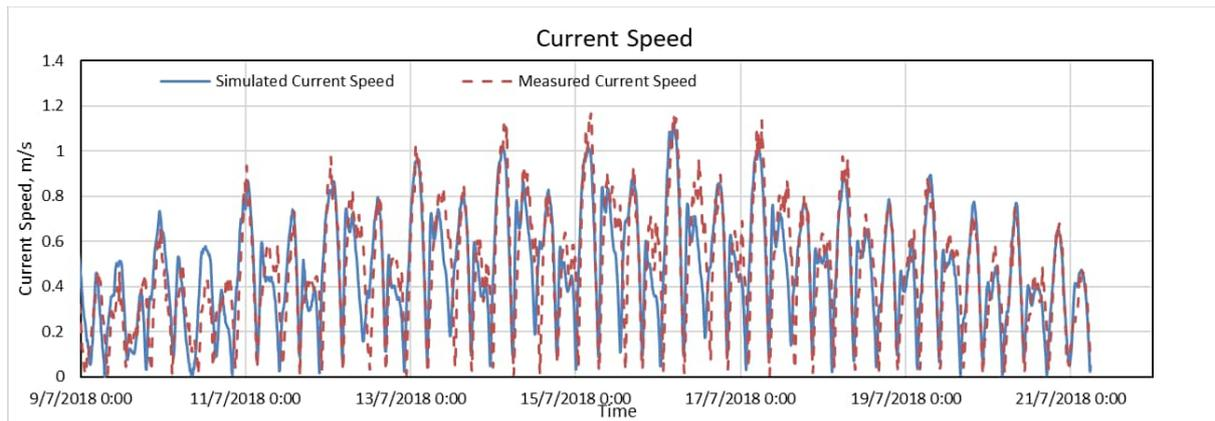

Figure N - 6 Comparison of current speeds between simulated and measured data for one full tidal cycle.

Table N - 2 Model performance against water level and current speed measurements

Parameters	Root Mean Square Error (RMSE)
Water Level	0.06 m
Current Speed	0.16 m/s

N.2 Morphology Modelling

The morphology modelling was based on the hydrodynamic model described in Section N.1. The simulated scenarios include projected sedimentation and erosion profiles in five (5) years with and without the mangrove restoration works.

N.3 Sediment Plume Modelling

The sediment plume modelling was conducted to simulate sediment plume generated by pond filling activities. It was also based on the hydrodynamic model described in Section N.1.

Due to the lack of detail construction methodology of pond filling activities, worst case scenario has been developed in order to provide a conservative assessment of sediment plume impacts. The below assumptions were made to conduct the analysis:

- The assessment was based on the peak filling rates, but in reality these would only occur for a short period of time during construction period;
- The calculations of loss rates of sediment to suspension were based on conservative methods of construction; and
- 8 working hours per day and 7 working days per week was assumed.

The sediment plume assessment was simulated over a 14-day period, capturing a full tidal cycle. The approach was considered to be conservative.

Sediment plume modelling works have been carried out for the main construction activities (i.e. earth filling works) during both southwest and northeast monsoon seasons. As there will be earth filling works at Pond 2 and Pond 3, three (3) filling scenarios, namely A-start of pond filling, B-50% of pond filling is completed, and C-end of pond filling, were set up for each pond (Figure N - 7). Hence, there are fourteen (14) simulated scenarios in total as summarised in Table N - 3.

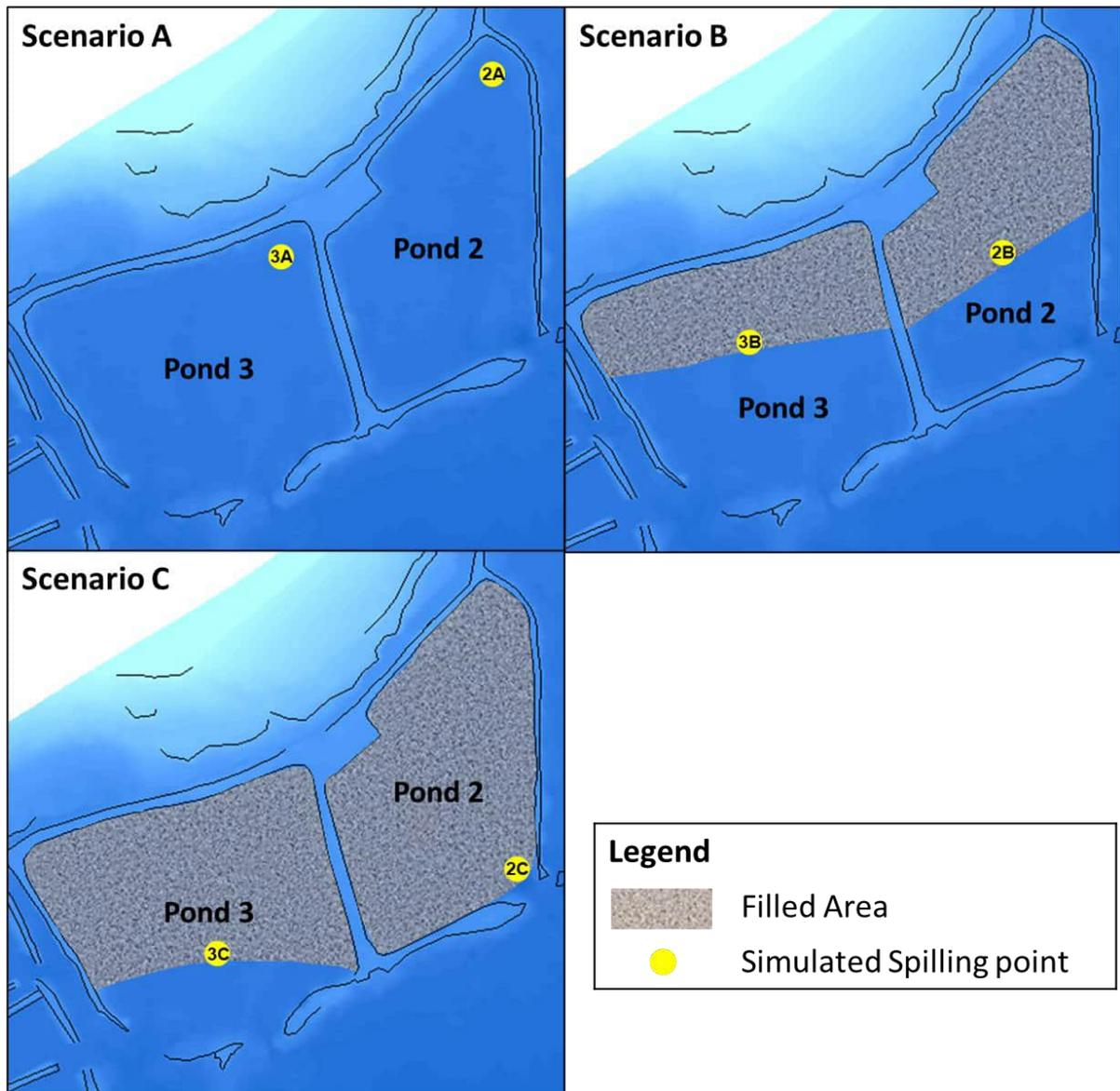

Figure N - 7 SSC spilling locations of sediment plume modelling scenario.

Table N - 3 Sediment plume modelling scenarios.

Monsoon	No Filling Activities		With Filling Activities	
Southwest (SW)	SW-Base	A: start of pond filling	SW2A	SW3A
		B: 50% of pond filling is completed	SW2B	SW3B
		C: end of pond filling	SW2C	SW3C
Northeast (NE)	NE-Base	A: start of pond filling	NE2A	NE3A
		B: 50% of pond filling is completed	NE2B	NE3B
		C: end of pond filling	NE2C	NE3C

Spill Properties

The construction/design information for the proposed development were provided by engineering design team as shown in Table N - 4.

Table N - 4 Construction/design information for the proposed development from engineering design team

Data Type	Inputs
Density of dredged marine clay and designed soil mix	16.0 kN/m ³
Size of bucket of amphibious excavator	1 m ³
Daily filling marine clay volume	250 m ³
Fine content of filling material	90% (based on filling criteria)

During pond filling processes, the percent of fine particles in infilling sands was assumed as 90% based on the filling criteria as provided by engineering design team. Spilling time is 8 hours as assumed above. Spill percent was assumed as 10% as the worst case during dumping process. When density of filling materia is 1600 kg/m³, the total spill per grab is estimated at about 1.25 kg/s. With mixing rate of spilling as 0.1 m³/s, the spilling clay concentration is around 12.5 kg/m³.

Appendix O
Marine Water
Model Results

Appendix O Marine Water Model Results

This Appendix provides the model plots obtained for the full tidal cycle condition from sediment plume modelling. The model results from hydrodynamic and morphology modelling and discussion on all the modelling results have been presented in the main EIS document. The following sections present the following results:

- Predicted Excess SSC with Minimum Controls (during Southwest Monsoon)
- Predicted Excess Sedimentation Rates with Minimum Controls (during Southwest Monsoon)
- Predicted Excess Sedimentation Rates with Mitigation Measures (during Southwest Monsoon)
- Predicted Excess SSC with Minimum Controls (during Northeast Monsoon)
- Predicted Excess Sedimentation Rates with Minimum Controls (during Northeast Monsoon)
- Predicted Excess Sedimentation Rates with Mitigation Measures (during Northeast Monsoon)

O.1 Predicted Excess SSC with Minimum Controls (during Southwest Monsoon)

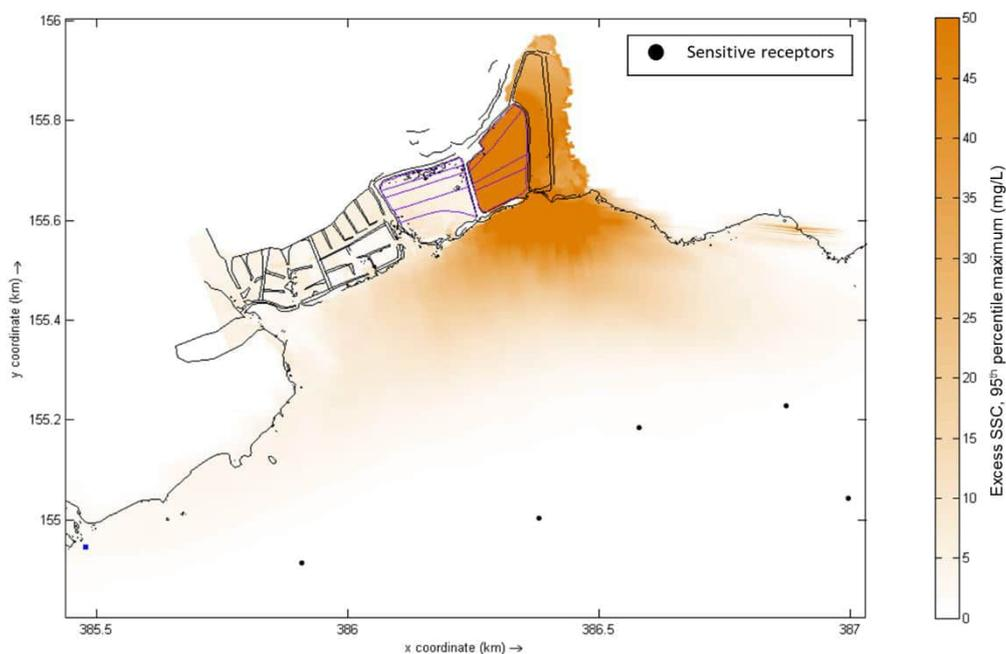

Figure O - 1 Maximum (95th percentile) excess SSC levels predicted from filling activities at Pond 2 with minimum controls during a full tidal cycle of southwest monsoon – start of pond filling (SW2A).

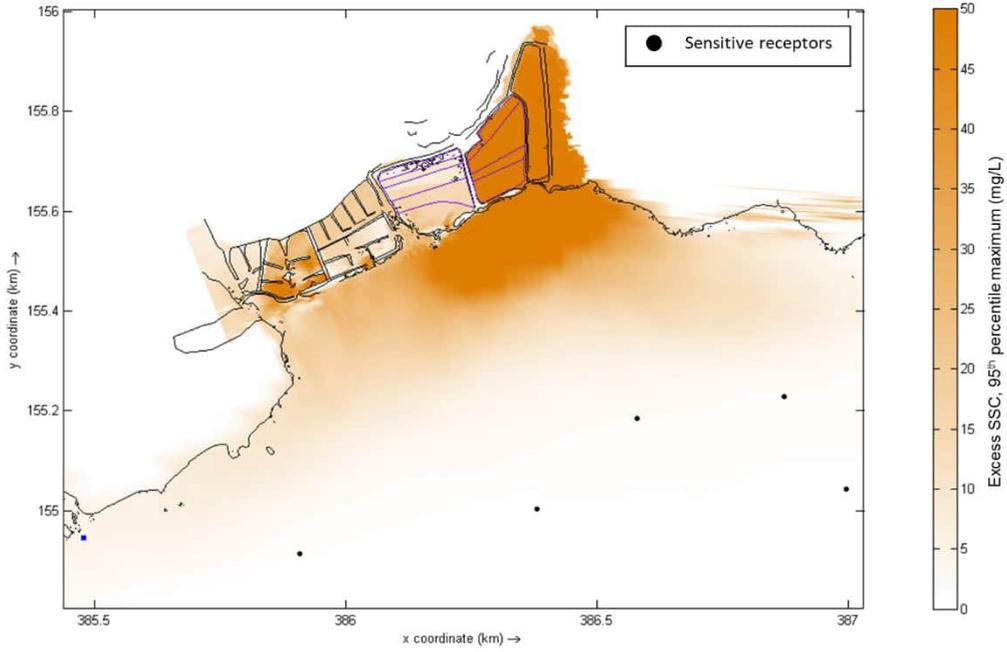

Figure O - 2 Maximum (95th percentile) excess SSC levels predicted from filling activities at Pond 2 with minimum controls during a full tidal cycle of southwest monsoon – 50% of pond filling is completed (SW2B).

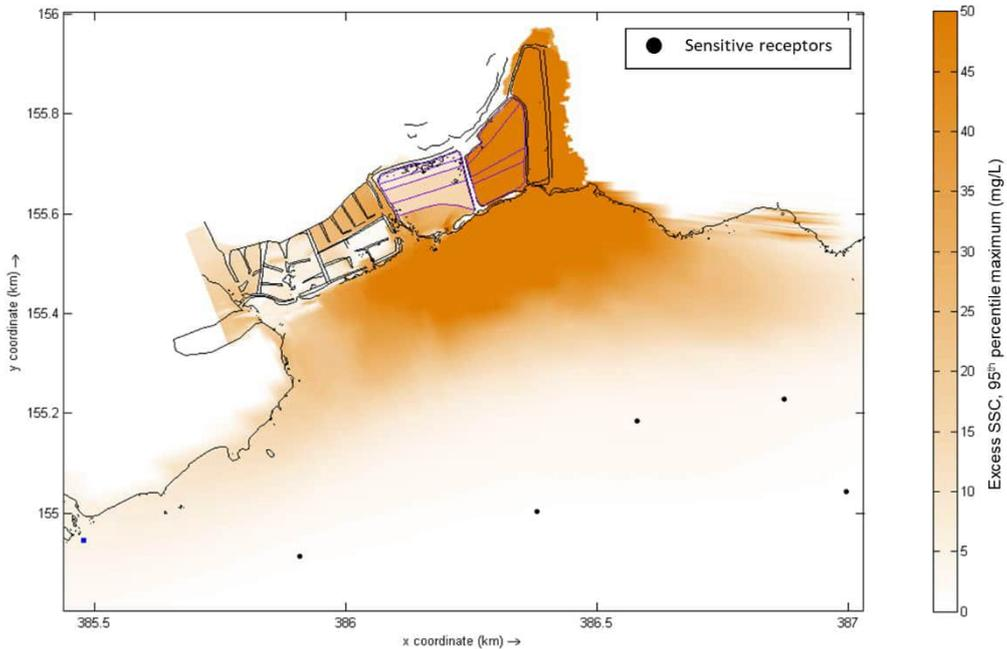

Figure O - 3 Maximum (95th percentile) excess SSC levels predicted from filling activities at Pond 2 with minimum controls during a full tidal cycle of southwest monsoon – end of pond filling (SW2C).

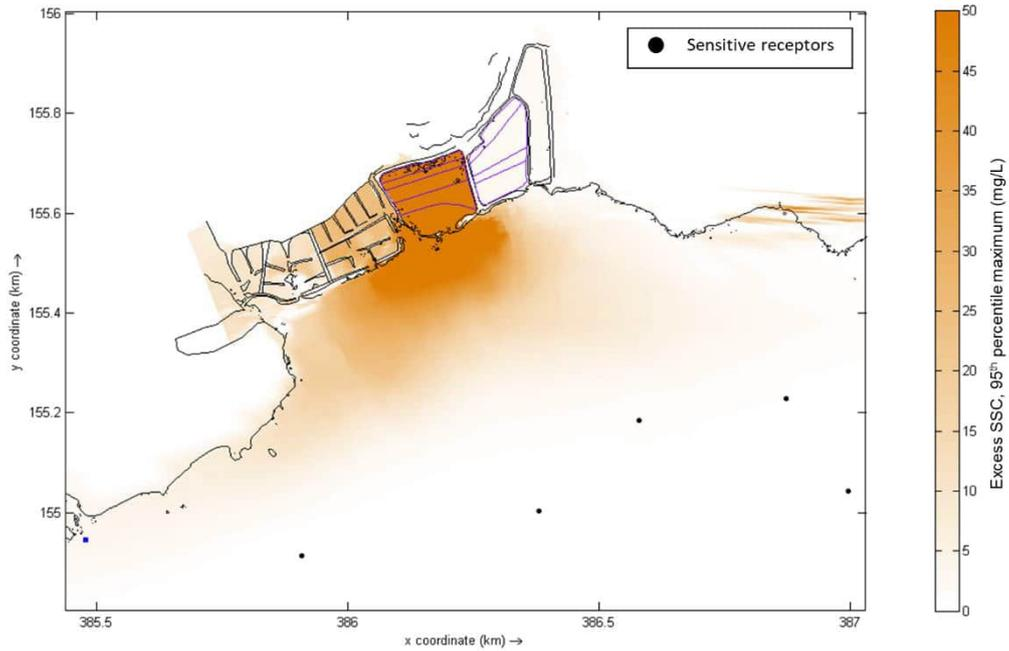

Figure O - 4 Maximum (95th percentile) excess SSC levels predicted from filling activities at Pond 3 with minimum controls during a full tidal cycle of southwest monsoon – start of pond filling (SW3A).

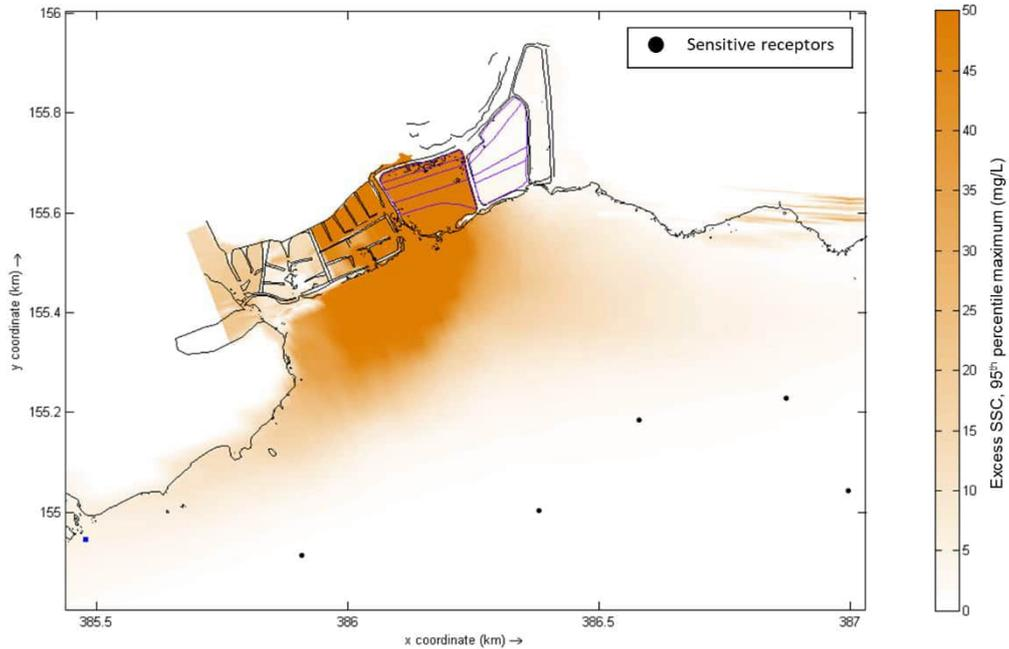

Figure O - 5 Maximum (95th percentile) excess SSC levels predicted from filling activities at Pond 3 with minimum controls during a full tidal cycle of southwest monsoon – 50% of pond filling is completed (SW3B).

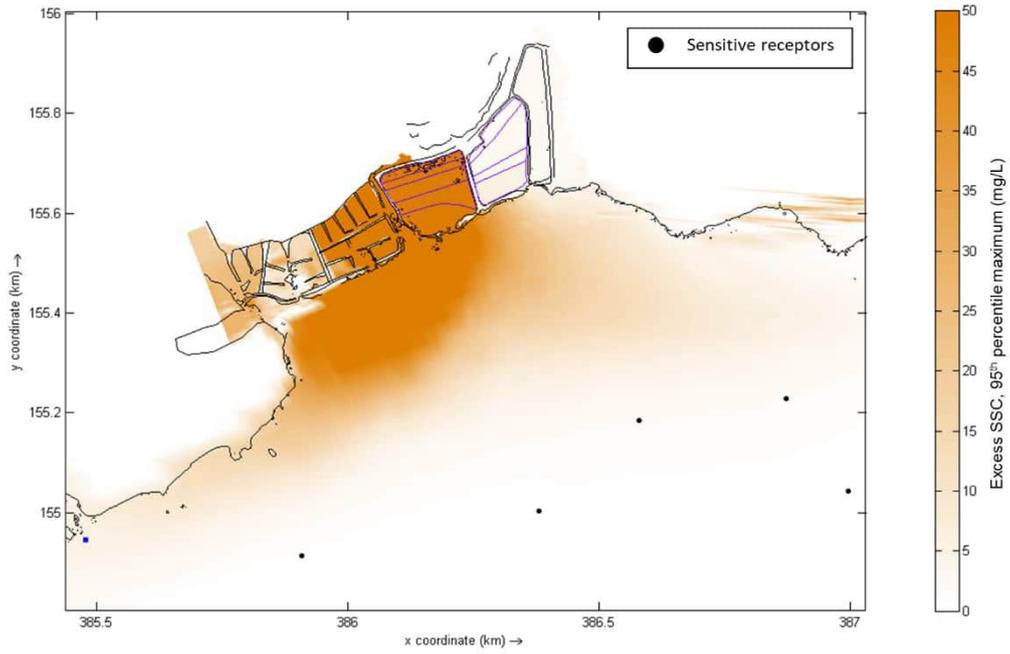

Figure O - 6 Maximum (95th percentile) excess SSC levels predicted from filling activities at Pond 3 with minimum controls during a full tidal cycle of southwest monsoon – end of pond filling (SW3C).

O.2 Predicted Excess Sedimentation Rates with Minimum Controls (during Southwest Monsoon)

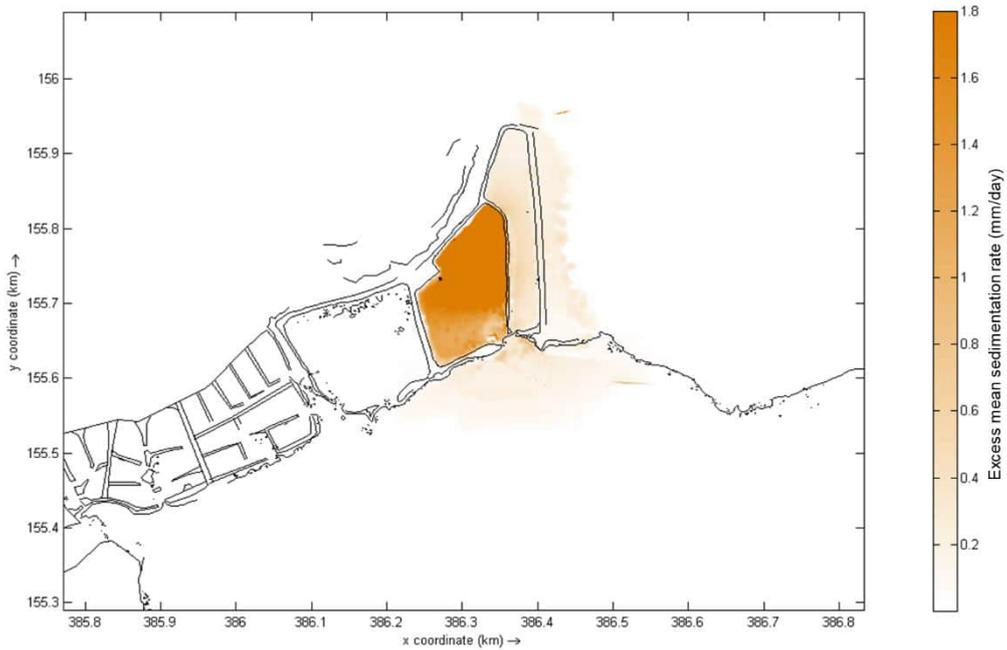

Figure O - 7 Maximum (95th percentile) excess sedimentation rate predicted from filling activities at Pond 2 with minimum controls during a full tidal cycle of southwest monsoon – start of pond filling (SW2A).

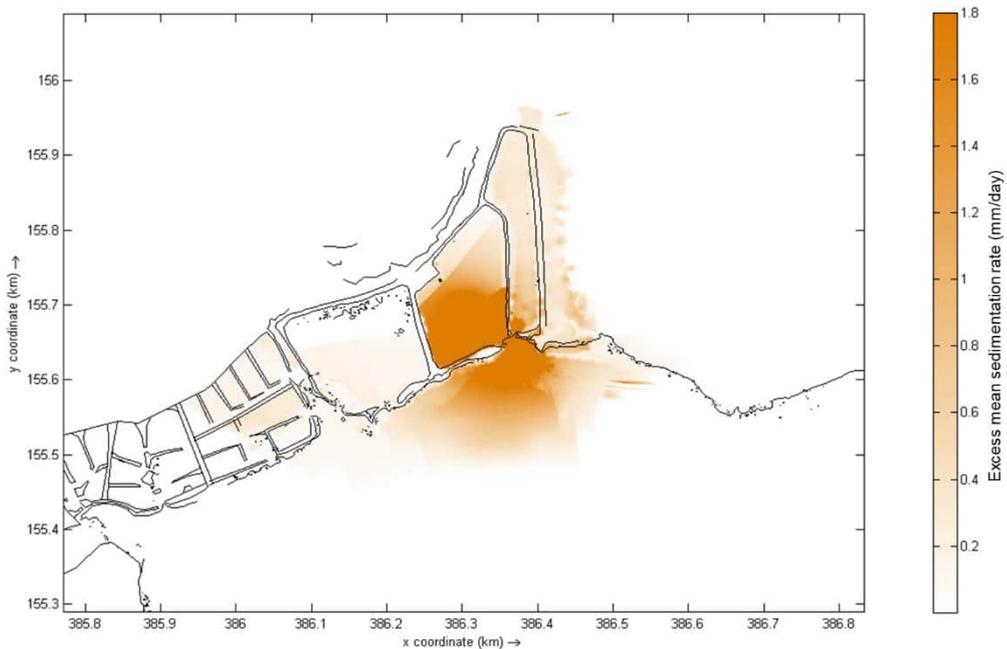

Figure O - 8 Maximum (95th percentile) excess sedimentation rate predicted from filling activities at Pond 2 with minimum controls during a full tidal cycle of southwest monsoon – 50% of pond filling is completed (SW2B).

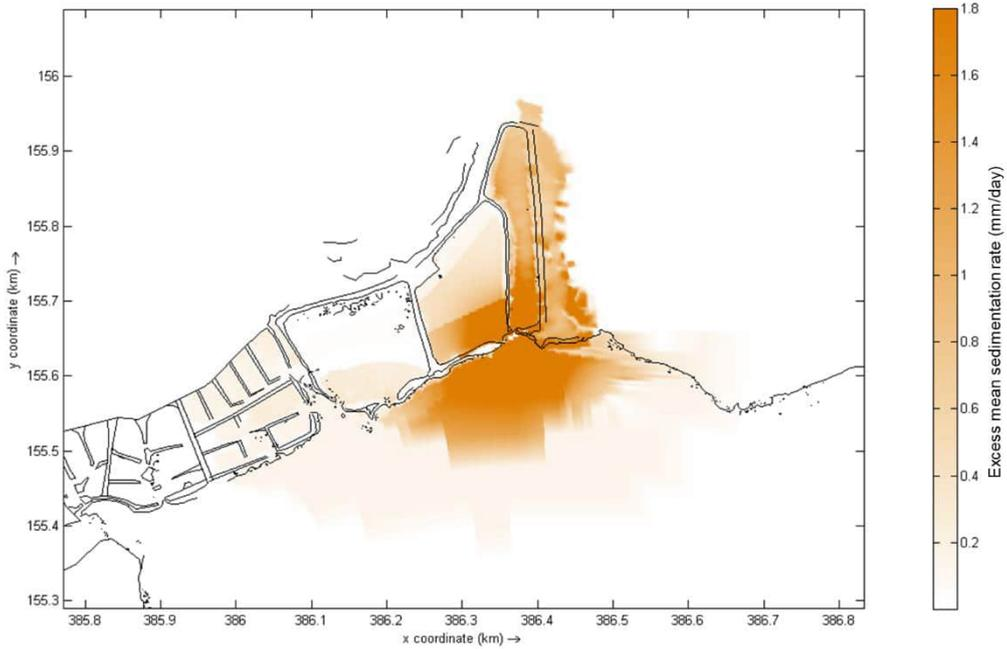

Figure O - 9 Maximum (95th percentile) excess sedimentation rate predicted from filling activities at Pond 2 with minimum controls during a full tidal cycle of southwest monsoon – end of pond filling (SW2C).

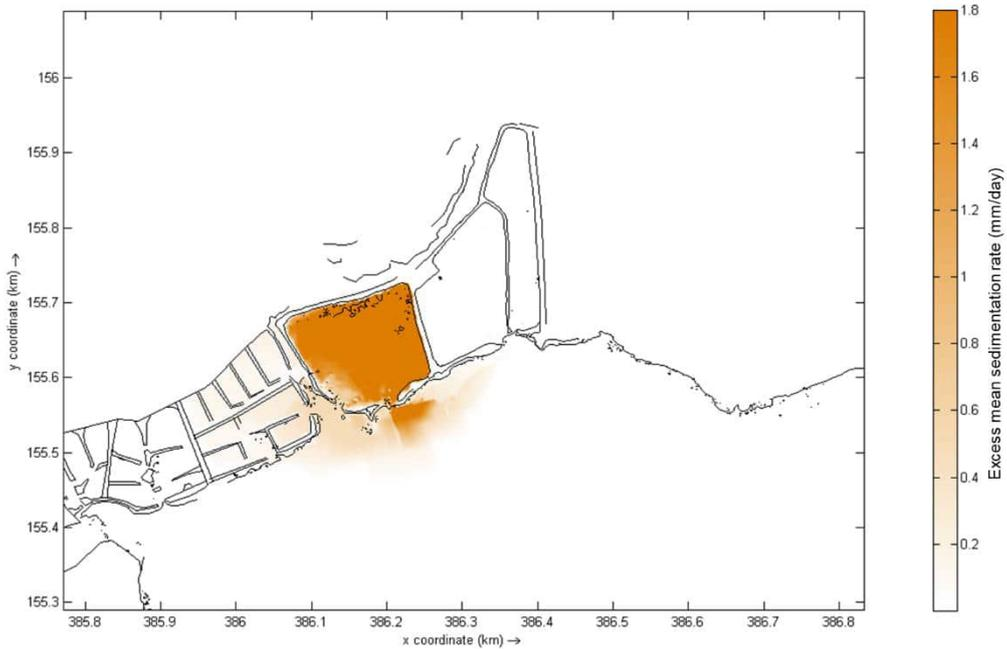

Figure O - 10 Maximum (95th percentile) excess sedimentation rate predicted from filling activities at Pond 3 with minimum controls during a full tidal cycle of southwest monsoon – start of pond filling (SW3A).

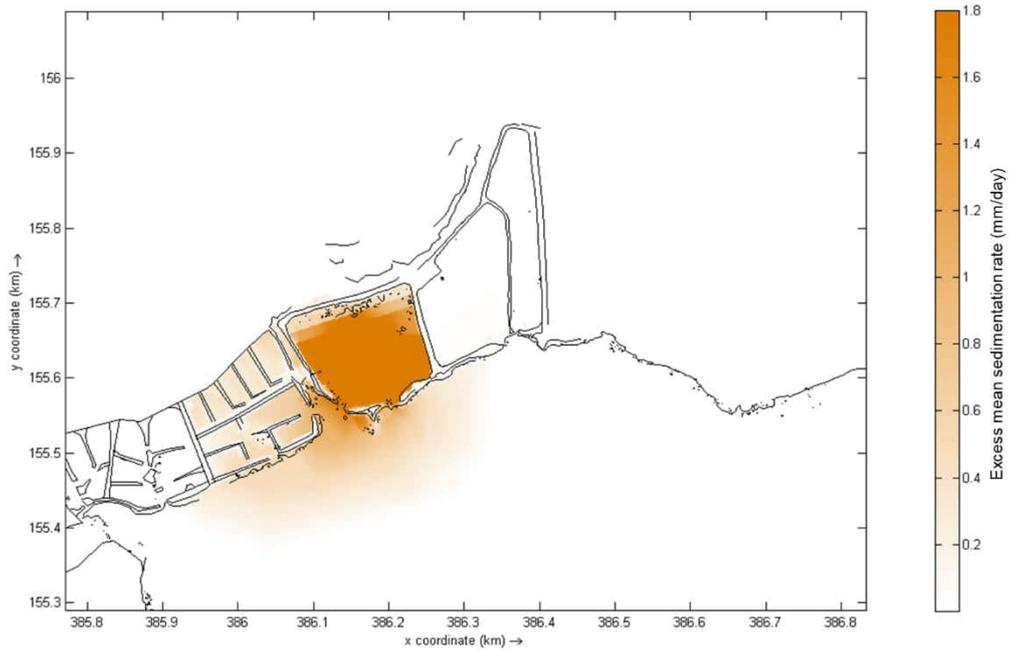

Figure O - 11 Maximum (95th percentile) excess sedimentation rate predicted from filling activities at Pond 3 with minimum controls during a full tidal cycle of southwest monsoon – 50% of pond filling is completed (SW3B).

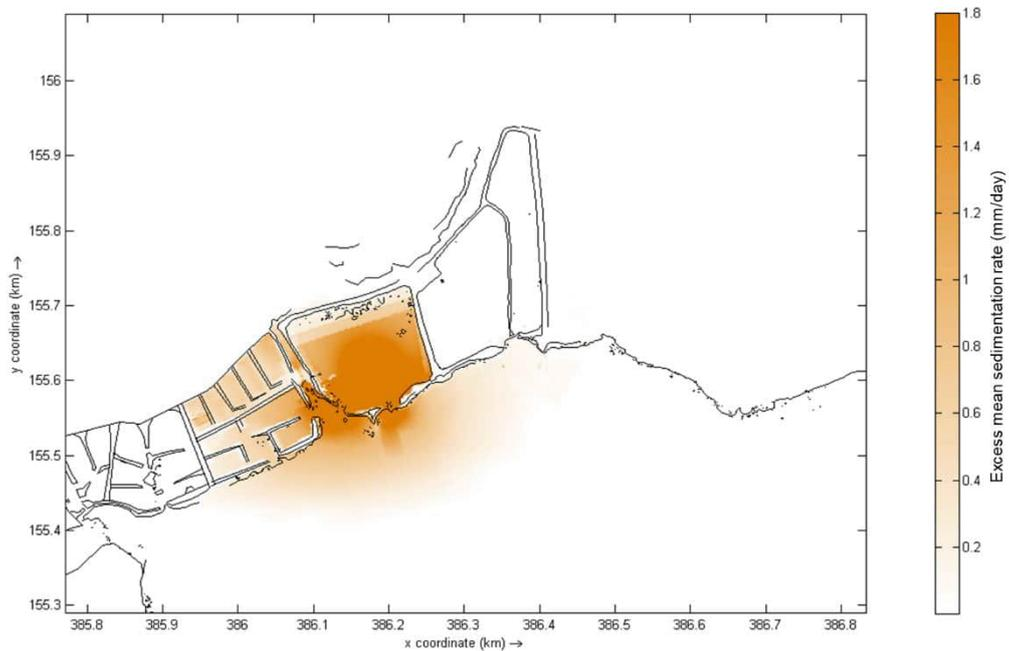

Figure O - 12 Maximum (95th percentile) excess sedimentation rate predicted from filling activities at Pond 3 with minimum controls during a full tidal cycle of southwest monsoon – end of pond filling (SW3C).

O.3 Predicted Excess Sedimentation Rates with Mitigation Measures (during Southwest Monsoon)

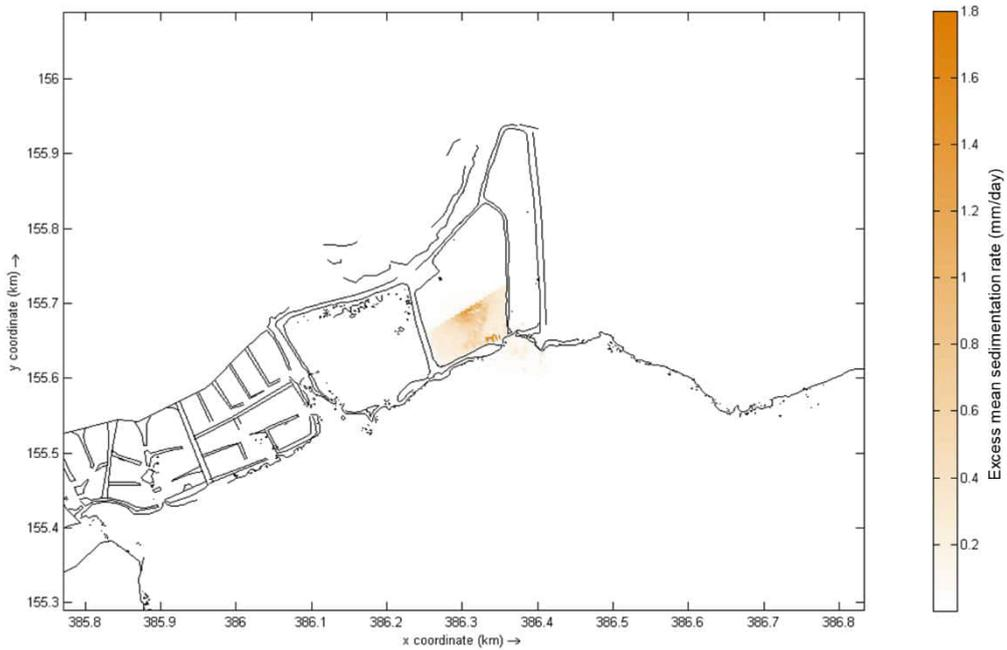

Figure O - 13 Maximum (95th percentile) excess sedimentation rate predicted from filling activities at Pond 2 with mitigation measures during a full tidal cycle of southwest monsoon – 50% of pond filling is completed (SW2B).

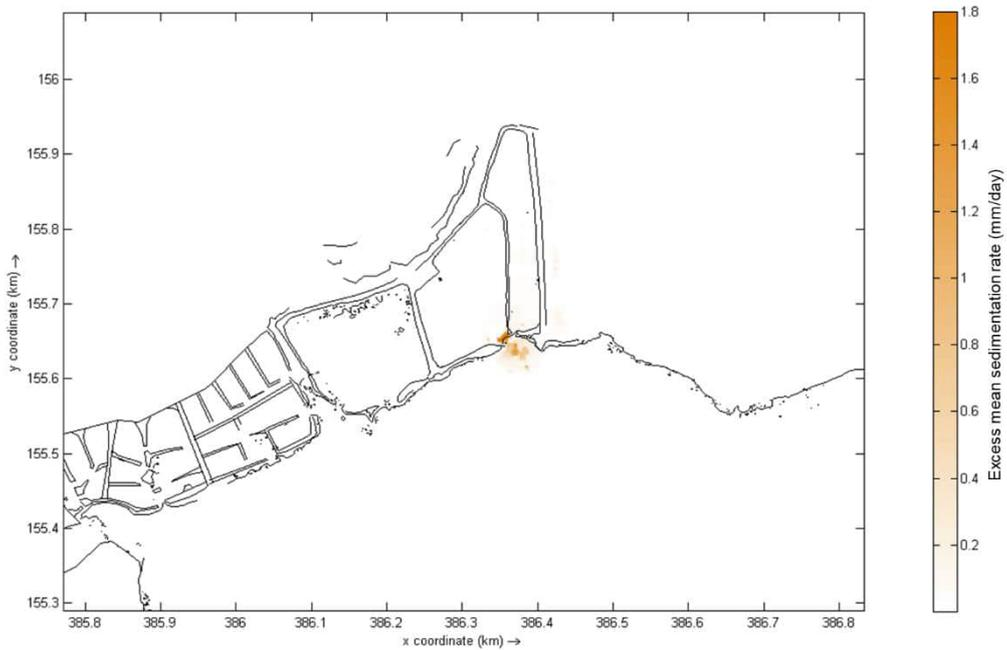

Figure O - 14 Maximum (95th percentile) excess sedimentation rate predicted from filling activities at Pond 2 with mitigation measures during a full tidal cycle of southwest monsoon – end of pond filling (SW2C).

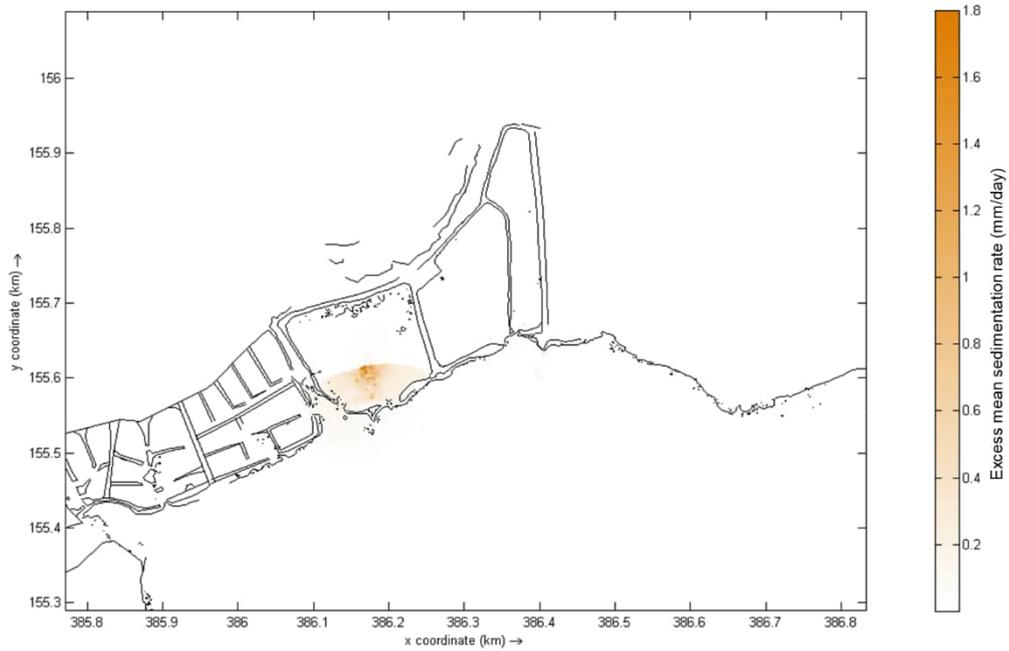

Figure O - 15 Maximum (95th percentile) excess sedimentation rate predicted from filling activities at Pond 3 with mitigation measures during a full tidal cycle of southwest monsoon – end of pond filling (SW3C).

O.4 Predicted Excess SSC with Minimum Controls (during Northeast Monsoon)

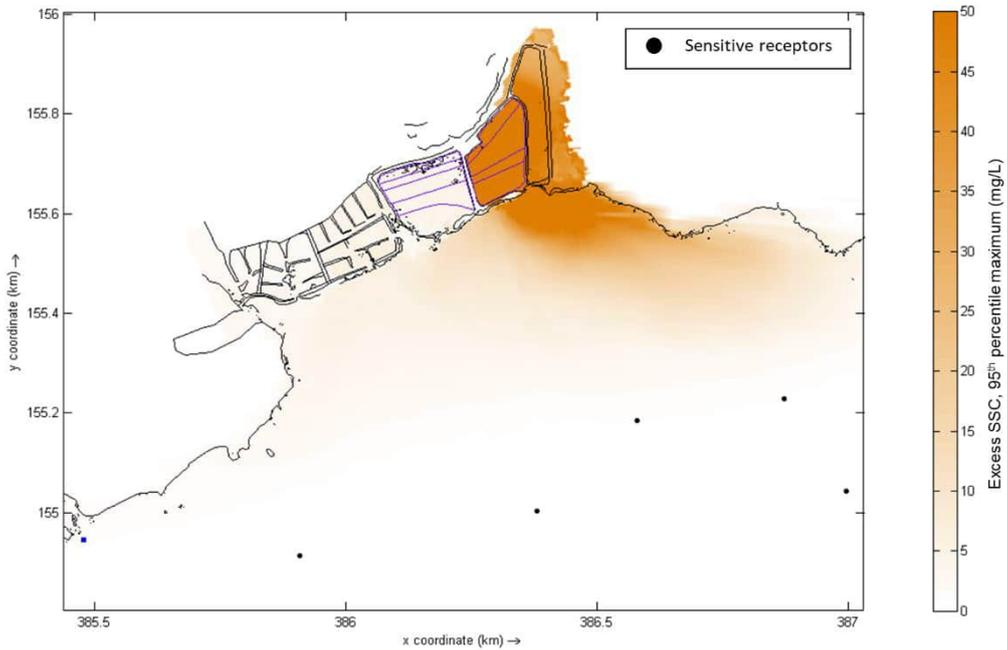

Figure O - 16 Maximum (95th percentile) excess SSC levels predicted from filling activities at Pond 2 with minimum controls during a full tidal cycle of northeast monsoon – start of pond filling (NE2A).

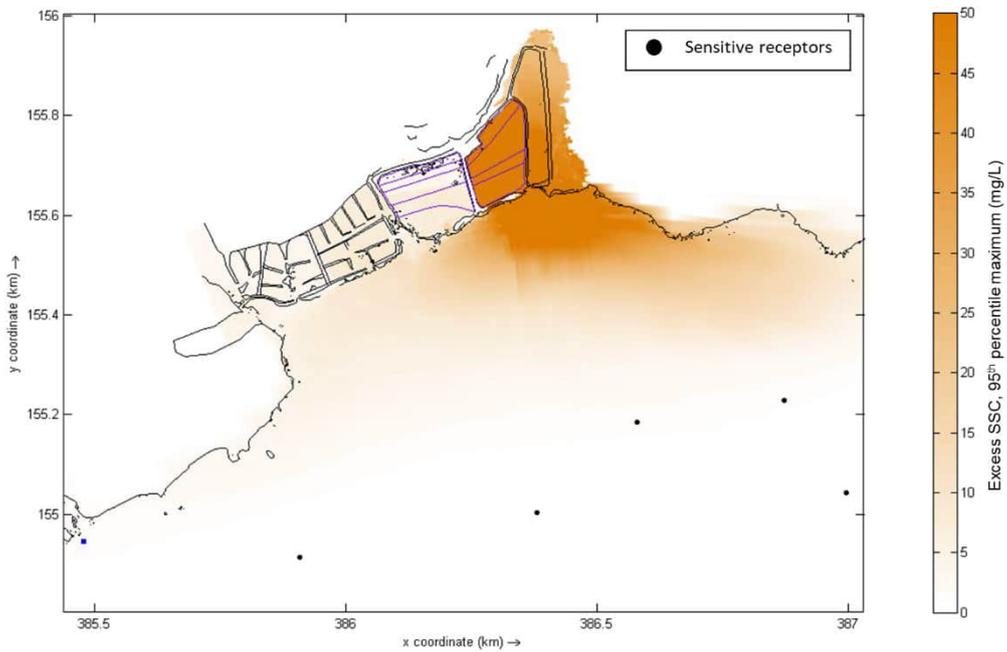

Figure O - 17 Maximum (95th percentile) excess SSC levels predicted from filling activities at Pond 2 with minimum controls during a full tidal cycle of northeast monsoon – 50% of pond filling is completed (NE2B).

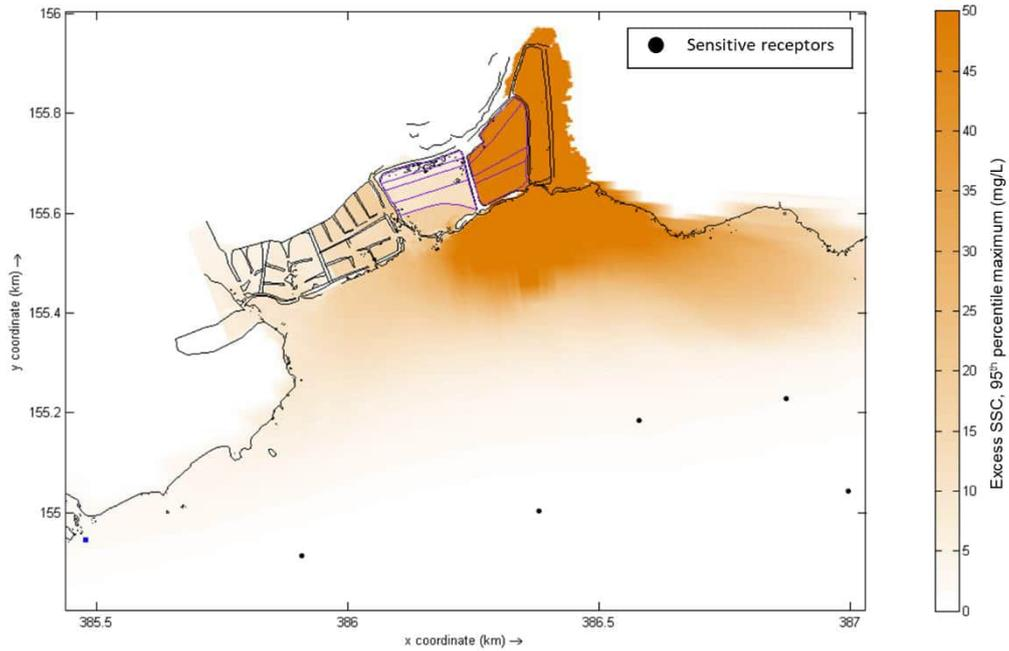

Figure O - 18 Maximum (95th percentile) excess SSC levels predicted from filling activities at Pond 2 with minimum controls during a full tidal cycle of northeast monsoon – end of pond filling (NE2C).

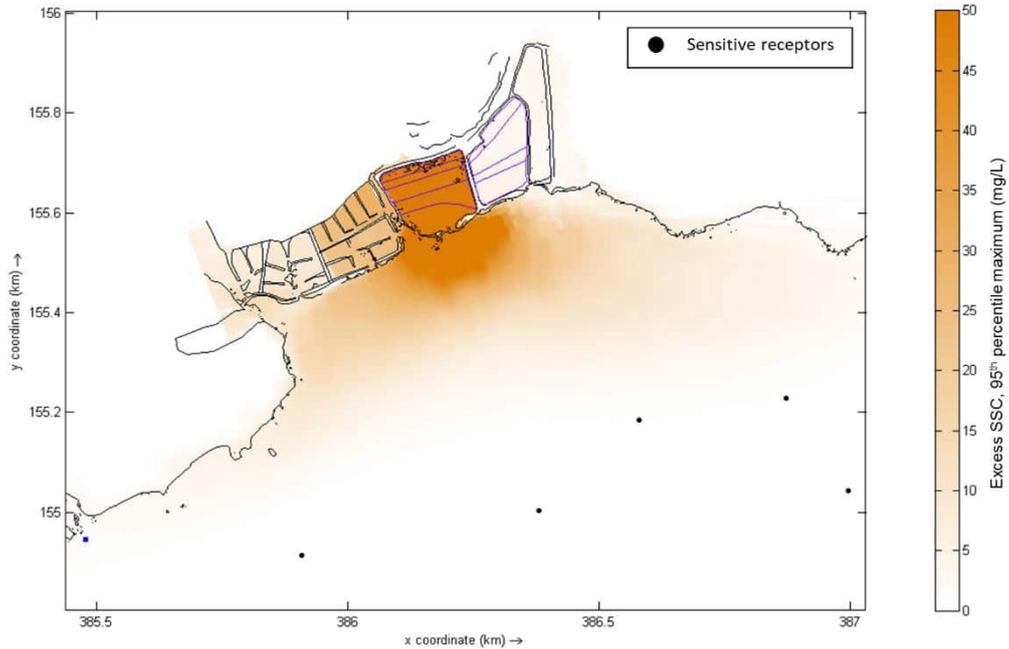

Figure O - 19 Maximum (95th percentile) excess SSC levels predicted from filling activities at Pond 3 with minimum controls during a full tidal cycle of northeast monsoon – start of pond filling (NE3A).

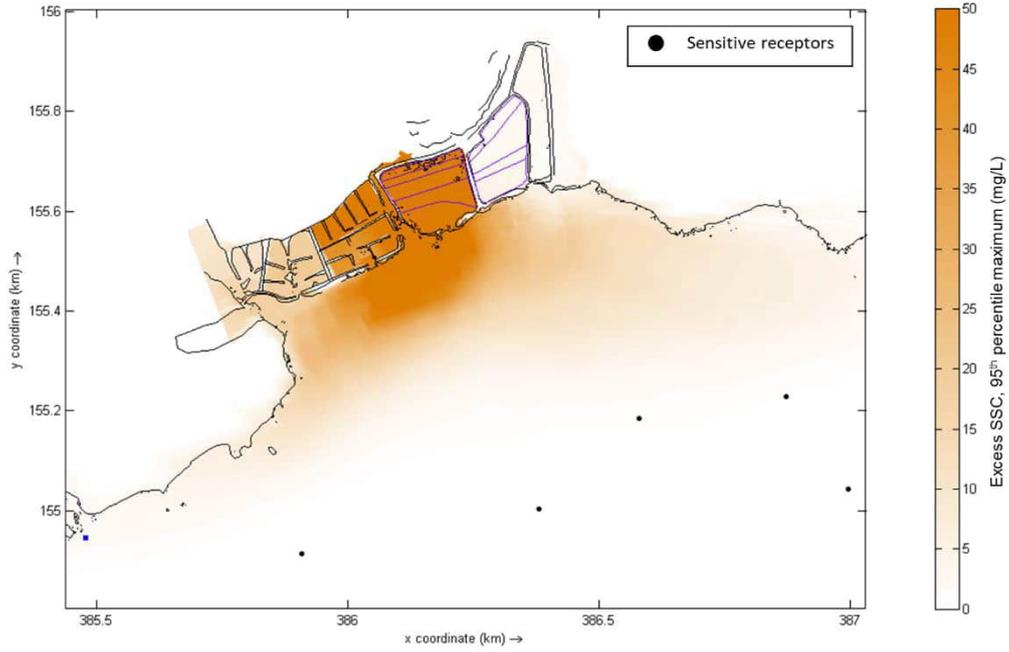

Figure O - 20 Maximum (95th percentile) excess SSC levels predicted from filling activities at Pond 3 with minimum controls during a full tidal cycle of northeast monsoon – 50% of pond filling is completed (NE3B).

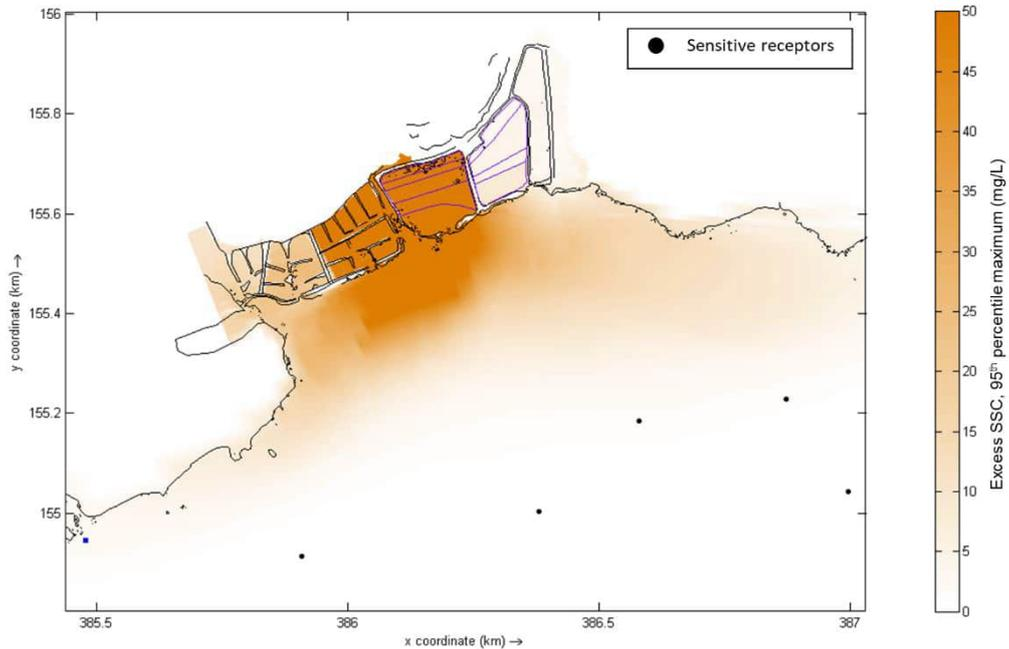

Figure O - 21 Maximum (95th percentile) excess SSC levels predicted from filling activities at Pond 3 with minimum controls during a full tidal cycle of northeast monsoon – end of pond filling (NE3C).

O.5 Predicted Excess Sedimentation Rates with Minimum Controls (during Northeast Monsoon)

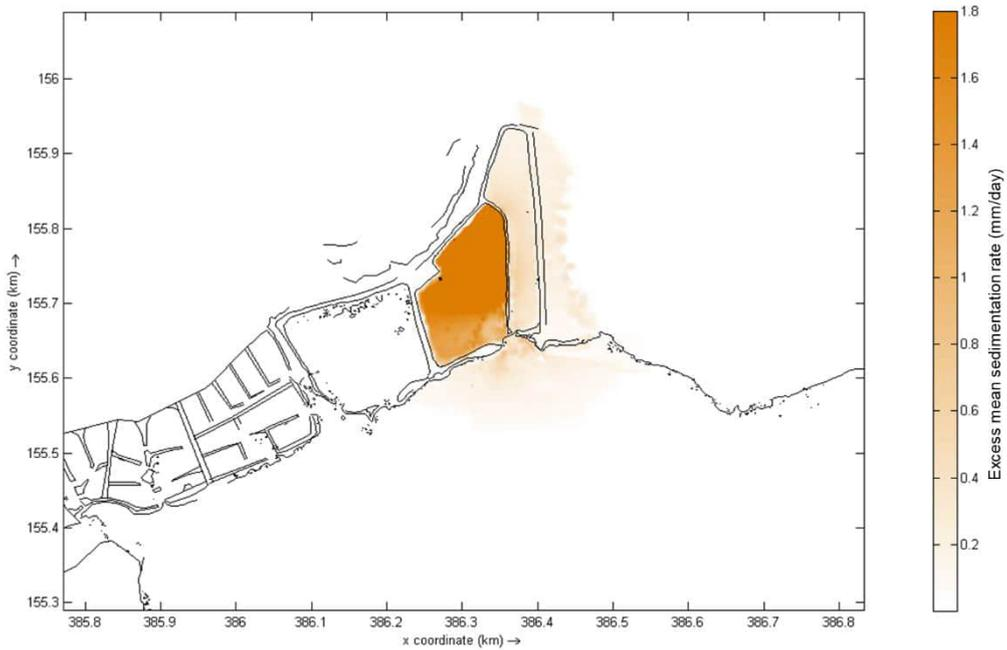

Figure O - 22 Maximum (95th percentile) excess sedimentation rates predicted from filling activities at Pond 2 with minimum controls during a full tidal cycle of northeast monsoon – start of pond filling (NE2A).

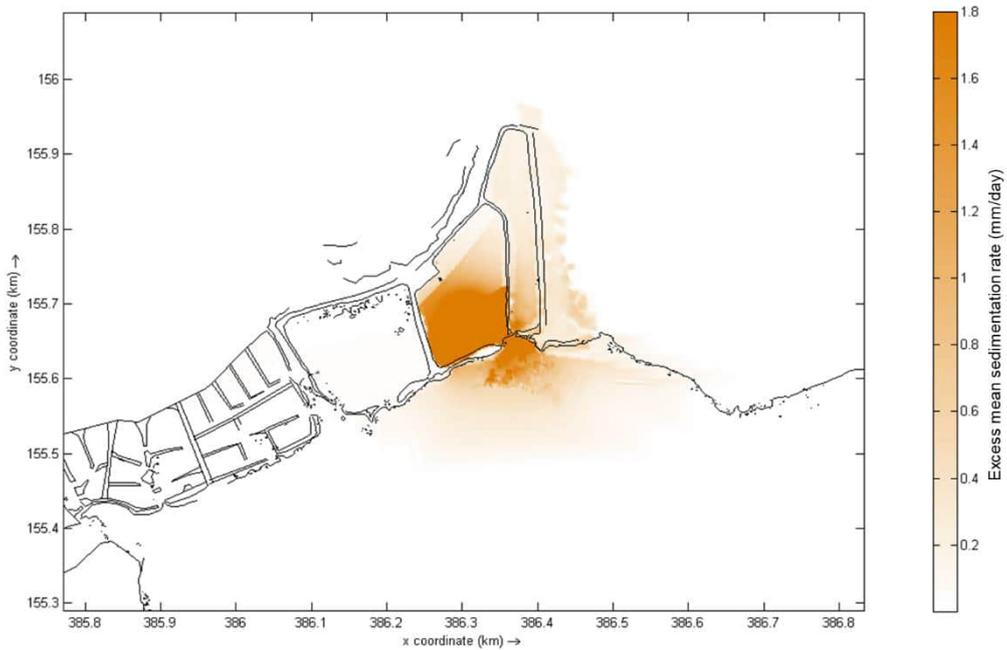

Figure O - 23 Maximum (95th percentile) excess sedimentation rates predicted from filling activities at Pond 2 with minimum controls during a full tidal cycle of northeast monsoon – 50% of pond filling is completed (NE2B).

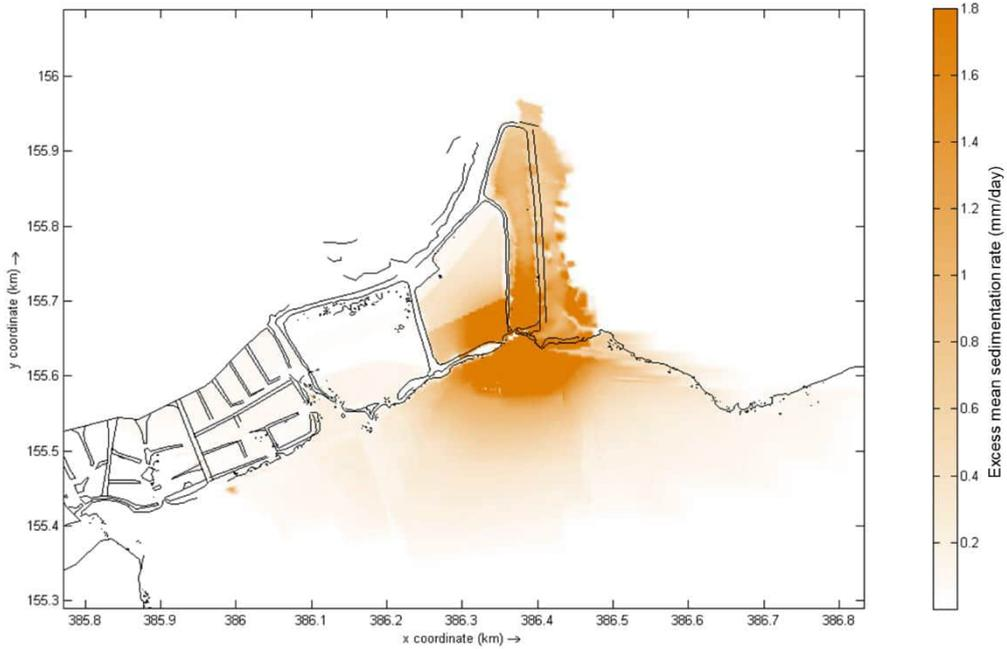

Figure O - 24 Maximum (95th percentile) excess sedimentation rates predicted from filling activities at Pond 2 with minimum controls during a full tidal cycle of northeast monsoon – end of pond filling (NE2C).

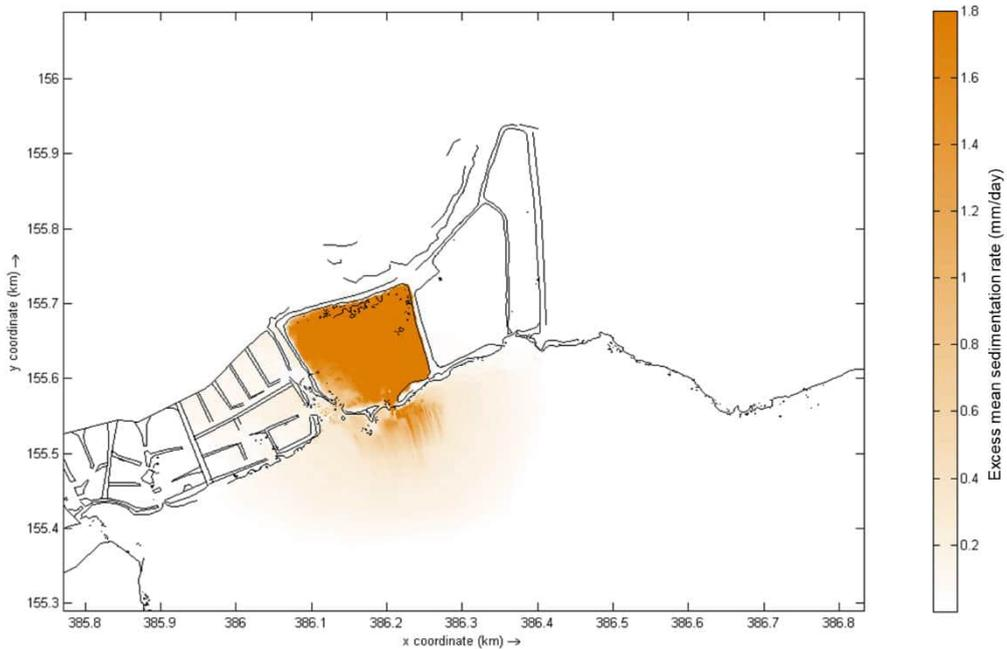

Figure O - 25 Maximum (95th percentile) excess sedimentation rates predicted from filling activities at Pond 3 with minimum controls during a full tidal cycle of northeast monsoon – start of pond filling (NE3A).

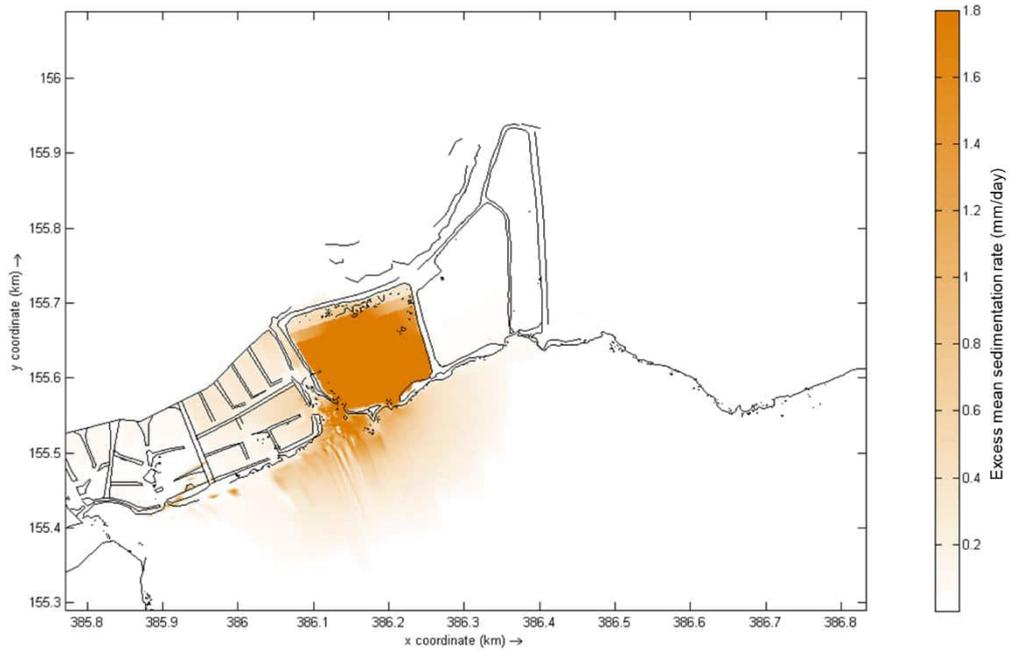

Figure O - 26 Maximum (95th percentile) excess sedimentation rates predicted from filling activities at Pond 3 with minimum controls during a full tidal cycle of northeast monsoon – 50% of pond filling is completed (NE3B).

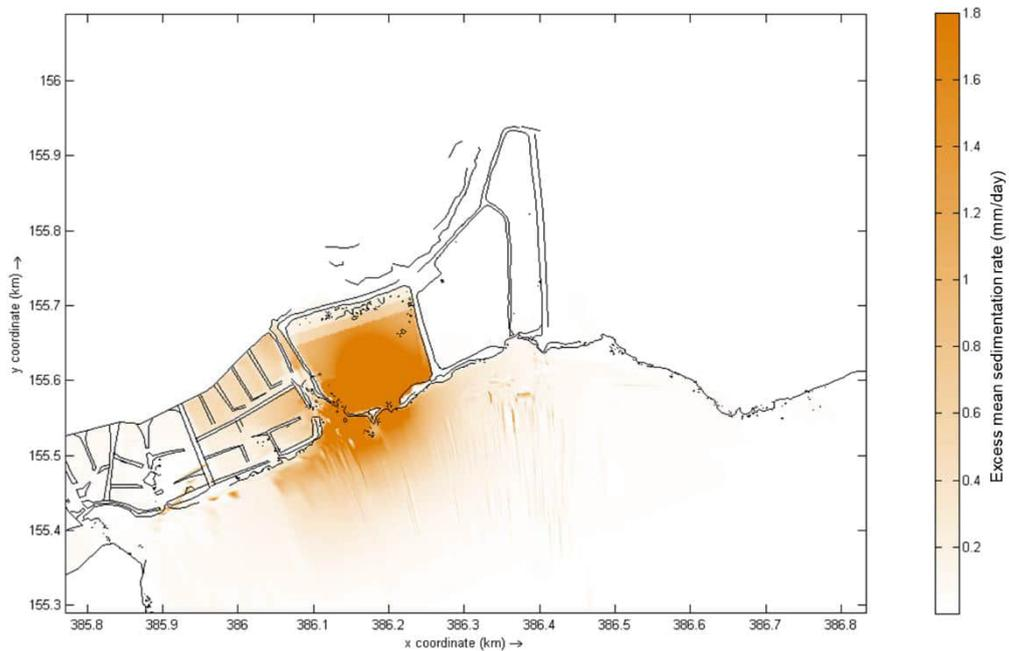

Figure O - 27 Maximum (95th percentile) excess sedimentation rates predicted from filling activities at Pond 3 with minimum controls during a full tidal cycle of northeast monsoon – end of pond filling (NE3C).

O.6 Predicted Excess Sedimentation Rates with Mitigation Measures (during Northeast Monsoon)

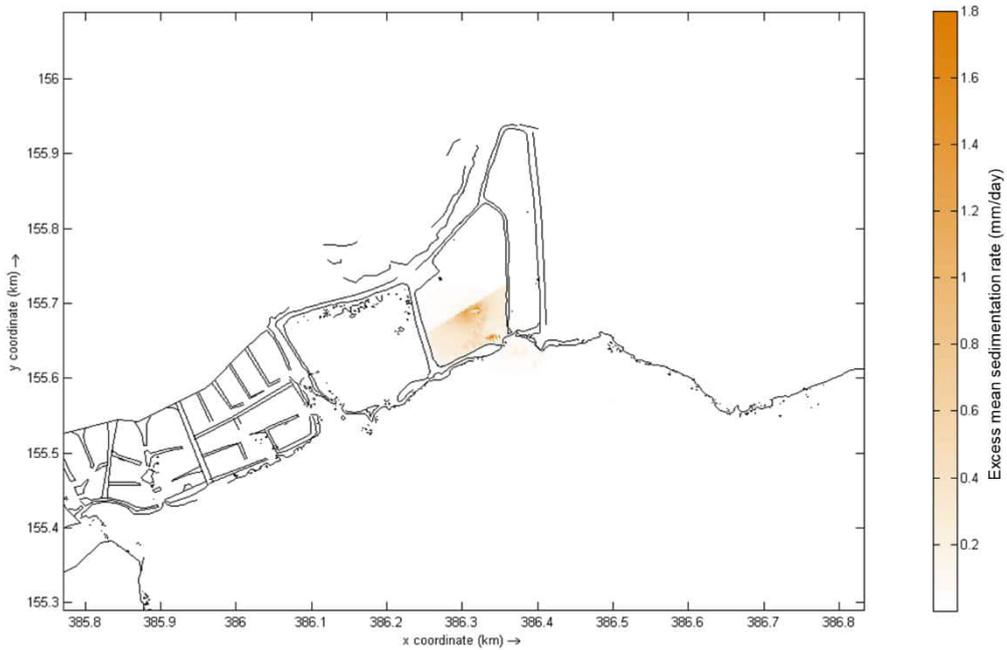

Figure O - 28 Maximum (95th percentile) excess sedimentation rates predicted from filling activities at Pond 2 with minimum controls during a full tidal cycle of northeast monsoon – 50% of pond filling is completed (NE2B).

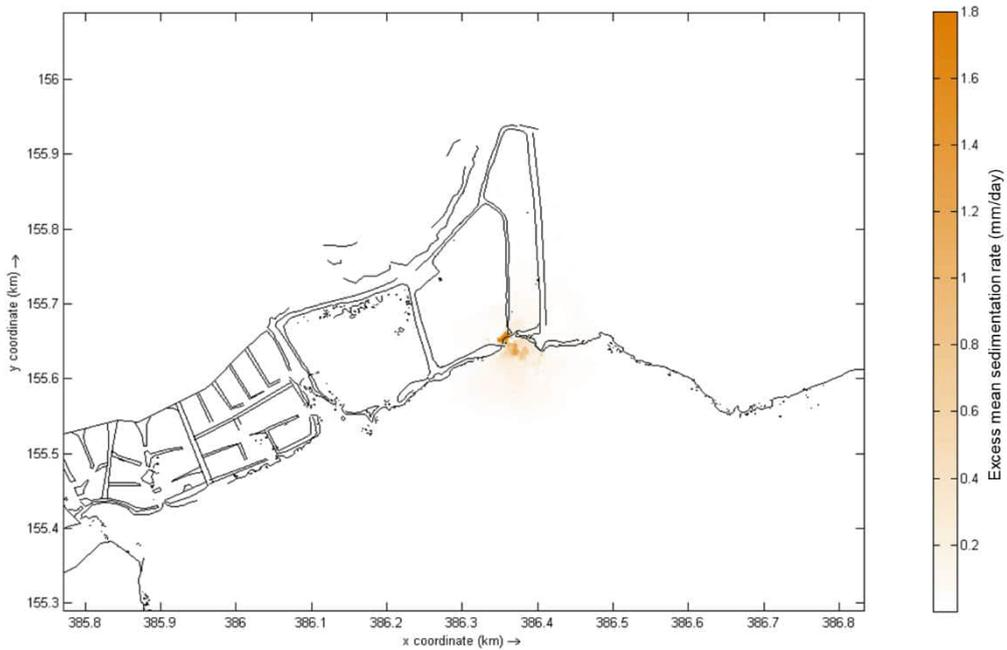

Figure O - 29 Maximum (95th percentile) excess sedimentation rates predicted from filling activities at Pond 2 with minimum controls during a full tidal cycle of northeast monsoon – end of pond filling (NE2C).

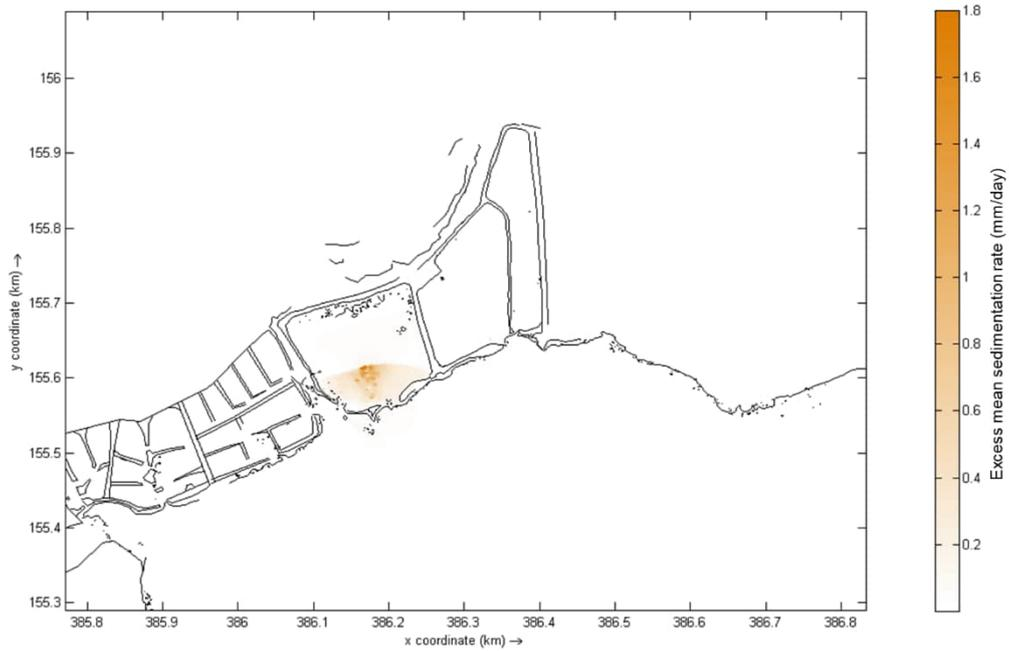

Figure O - 30 Maximum (95th percentile) excess sedimentation rates predicted from filling activities at Pond 3 with minimum controls during a full tidal cycle of northeast monsoon – end of pond filling (NE3C).

Appendix P
Baseline Water Quality
Reports and Sediment
Reports

TEST REPORT

Our Reference No. : **R221584/1**
Project Code / Ref. : 60579645 Pulau Ubin Shoreline

Date Received : 10/03/2022
Date Commenced : 10/03/2022
Date Reported : 04/04/2022

Customer Ref. No. : -
Customer Name : AECOM Singapore Pte Ltd
Customer Address : 300 Beach Road
#03-00 The Concourse
Singapore 199555

Attention To : Ms Jacquelynn Chia

Sample Description : 10 Water samples as per received.

RESULTS : Refer to Page 2 to Page 3

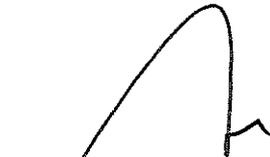

Tan Thuan Piang
Technical Manager

Terms & Conditions:

- 1) This report shall not be reproduced except in full, unless approval in writing has been given by MLS.
- 2) The results in this report only apply to the sample received/analysed.
- 3) MLS agrees to use reasonable diligence in the performance of the service.

Marchwood Laboratory Services Pte Ltd:
Main (Office and Laboratory):
Branch (Site and Laboratory):
Website:

Co. Reg No. : 201422686C
116 Tuas South Ave 2, West Point Bizhub Singapore 637163
216 Tuas South Ave 2, West Point Bizhub Singapore 637213
www.mls.sg

 : +65 6790 0118
 : +65 6262 3736 (Lab)

 : +65 6790 0091
 : +65 6262 3726 / 3776 (Site)

R221584/1

RESULTS

Test Parameter	Unit	Test Method	Sample 1		Sample 2		Sample 3		Sample 4		Sample 5		LOR
			WQ1-NF 09/03/2022	WQ2-NF 09/03/2022	WQ3-NF 09/03/2022	WQ4-NF 09/03/2022	WQ5-NF 09/03/2022						
pH value	-	APHA 4500-H+ (B)	6.4	8.1	8.1	8.0	8.0	8.0	8.0	8.0	8.0	-	
Total Suspended Solids as TSS	mg/L	APHA 2540D	17.0	25.0	19.2	69.3	19.2	69.3	40.3	40.3	40.3	1	
Total Nitrogen as TN	mg/L	APHA 4500-P (J)	0.60	0.64	0.63	0.47	0.63	0.47	0.60	0.60	0.60	0.01	
Total Phosphorus as TP	mg/L	APHA 4500-P (J)	0.036	0.027	0.038	0.032	0.038	0.032	0.038	0.038	0.038	0.01	
Ammonia as NH ₄ -N	mg/L	APHA 4500-NH ₃ (H)	0.19	0.14	0.13	0.12	0.13	0.12	0.062	0.062	0.062	0.01	
Nitrate as NO ₃ -N	mg/L	APHA 4500-NO ₃ (I)	0.0098	0.033	0.034	0.036	0.034	0.036	0.033	0.033	0.033	0.005	
Nitrite as NO ₂ -N	mg/L	APHA 4500-NO ₃ (I)	<0.02	0.040	0.042	0.032	0.042	0.032	0.028	0.028	0.028	0.02	
Orthophosphates as PO ₄ -P	mg/L	APHA 4500-P (G)	0.035	0.025	0.037	0.028	0.037	0.028	0.021	0.021	0.021	0.005	
Biochemical Oxygen Demand as BOD	mg/L	APHA 5210B	<1	1.82	<1	1.52	<1	1.52	1.63	1.63	1.63	1	
Phenolic compounds as Phenols	mg/L	APHA 5530D	<0.025	<0.025	<0.025	<0.025	<0.025	<0.025	<0.025	<0.025	<0.025	0.025	
Cyanide as CN	mg/L	APHA 4500-CN- (N)	<0.005	<0.005	<0.005	<0.005	<0.005	<0.005	<0.005	<0.005	<0.005	0.005	
Arsenic as As	µg/L	APHA 3125B	2.04	2.22	2.32	2.28	2.32	2.28	2.25	2.25	2.25	0.5	
Cadmium as Cd	µg/L	APHA 3125B	<0.5	<0.5	<0.5	<0.5	<0.5	<0.5	<0.5	<0.5	<0.5	0.5	
Chromium as Cr (Total)	µg/L	APHA 3125B	4.58	4.55	4.65	4.73	4.65	4.73	4.68	4.68	4.68	0.5	
Chromium as Cr (VI)	µg/L	APHA 3500-Cr (B)	<25	<25	<25	<25	<25	<25	<25	<25	<25	25	
Copper as Cu	µg/L	APHA 3125B	0.81	0.79	0.74	0.78	0.74	0.78	0.71	0.71	0.71	0.5	
Mercury as Hg	µg/L	APHA 3125B	<0.1	<0.1	<0.1	<0.1	<0.1	<0.1	<0.1	<0.1	<0.1	0.1	
Nickel as Ni	µg/L	APHA 3125B	1.34	1.19	1.16	1.37	1.16	1.37	1.23	1.23	1.23	0.5	
Lead as Pb	µg/L	APHA 3125B	<0.5	<0.5	<0.5	<0.5	<0.5	<0.5	<0.5	<0.5	<0.5	0.5	
Zinc as Zn	µg/L	APHA 3125B	1.50	1.47	1.52	2.12	1.52	2.12	0.69	0.69	0.69	0.5	
Free Chlorine	mg/L	Lovibond Test Kit (DPD) Rev 1.0	<0.2	<0.2	<0.2	<0.2	<0.2	<0.2	<0.2	<0.2	<0.2	0.2	
Tributyltin*	ng/L	GC-MS	30.0	20.0	40.0	<10	40.0	<10	20.0	20.0	20.0	10	
Faecal Coliform	MPN/100mL	APHA 9221E	20	2	17	2	17	2	14	14	14	2	
Enterococcus	cfu/100mL	APHA 9230C	152	43	48	124	48	124	1,200	1,200	1,200	1	
Oil & Grease (Total)	mg/L	In-house method MLS-SOP-WQ-033 Rev 0 (adapted from APHA 5520C)	0.22	<0.1	<0.1	<0.1	<0.1	<0.1	<0.1	<0.1	<0.1	0.1	

Note:

1. APHA is a standard method for Determination of Water and Waste Water (APHA 23rd Edition, 2017)
2. "<" = Less than. The data reported is less than Detection Limit of the test.
3. "*" = The test was sub-contracted to external lab.

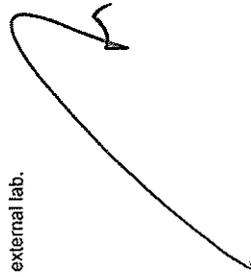

RESULTS

Test Parameter	Unit	Test Method	Sample 6		Sample 7		Sample 8		Sample 9		Sample 10		LOR
			WQ1-NE 09/03/2022	WQ2-NE 09/03/2022	WQ3-NE 09/03/2022	WQ4-NE 09/03/2022	WQ5-NE 09/03/2022						
pH value	-	APHA 4500-H+ (B)	7.1	8.0	8.2	8.1	8.1	8.1	8.1	8.1	8.1	-	
Total Suspended Solids as TSS	mg/L	APHA 2540D	10.0	10.3	10.7	11.3	13.1	13.1	13.1	13.1	13.1	1	
Total Nitrogen as TN	mg/L	APHA 4500-P (J)	0.62	0.56	0.40	0.59	0.45	0.45	0.45	0.45	0.45	0.01	
Total Phosphorus as TP	mg/L	APHA 4500-P (J)	0.032	0.027	0.033	0.036	0.036	0.036	0.036	0.036	0.036	0.01	
Ammonia as NH ₄ -N	mg/L	APHA 4500-NH ₃ (H)	0.22	0.066	0.046	0.068	0.042	0.042	0.042	0.042	0.042	0.01	
Nitrate as NO ₃ -N	mg/L	APHA 4500-NO ₃ (I)	0.0069	0.033	0.034	0.036	0.046	0.046	0.046	0.046	0.046	0.005	
Nitrite as NO ₂ -N	mg/L	APHA 4500-NO ₃ (I)	<0.02	0.036	0.039	0.041	0.024	0.024	0.024	0.024	0.024	0.02	
Orthophosphates as PO ₄ -P	mg/L	APHA 4500-P (G)	0.030	0.025	0.030	0.032	0.030	0.030	0.030	0.030	0.030	0.005	
Biochemical Oxygen Demand as BOD	mg/L	APHA 5210B	1.91	1.40	<1	<1	<1	<1	<1	<1	<1	1	
Phenolic compounds as Phenols	mg/L	APHA 5530D	<0.025	<0.025	<0.025	<0.025	<0.025	<0.025	<0.025	<0.025	<0.025	0.025	
Cyanide as CN	mg/L	APHA 4500-CN- (N)	<0.005	<0.005	<0.005	<0.005	<0.005	<0.005	<0.005	<0.005	<0.005	0.005	
Arsenic as As	µg/L	APHA 3125B	2.26	2.02	2.30	2.33	2.18	2.18	2.18	2.18	2.18	0.5	
Cadmium as Cd	µg/L	APHA 3125B	<0.5	<0.5	<0.5	<0.5	<0.5	<0.5	<0.5	<0.5	<0.5	0.5	
Chromium as Cr (Total)	µg/L	APHA 3125B	4.50	4.49	4.55	4.42	4.75	4.75	4.75	4.75	4.75	0.5	
Chromium as Cr (VI)	µg/L	APHA 3500-Cr (B)	<25	<25	<25	<25	<25	<25	<25	<25	<25	25	
Copper as Cu	µg/L	APHA 3125B	<0.5	0.73	0.78	0.88	0.68	0.68	0.68	0.68	0.68	0.5	
Mercury as Hg	µg/L	APHA 3125B	<0.1	<0.1	<0.1	<0.1	<0.1	<0.1	<0.1	<0.1	<0.1	0.1	
Nickel as Ni	µg/L	APHA 3125B	1.11	1.29	1.38	1.17	1.22	1.22	1.22	1.22	1.22	0.5	
Lead as Pb	µg/L	APHA 3125B	<0.5	<0.5	<0.5	<0.5	<0.5	<0.5	<0.5	<0.5	<0.5	0.5	
Zinc as Zn	µg/L	APHA 3125B	2.41	1.09	3.06	<0.5	1.27	1.27	1.27	1.27	1.27	0.5	
Free Chlorine	mg/L	Lovibond Test Kit (DPD) Rev 1.0	<0.2	<0.2	<0.2	<0.2	<0.2	<0.2	<0.2	<0.2	<0.2	0.2	
Tributyltin*	ng/L	GC-MS	10.0	<10	<10	30.0	<10	<10	<10	<10	<10	10	
Faecal Coliform	MPN/100mL	APHA 9221E	110	10	120	58	8.2	8.2	8.2	8.2	8.2	2	
Enterococcus	cfu/100mL	APHA 9230C	236	36	136	202	102	102	102	102	102	1	
Oil & Grease (Total)	mg/L	In-house method MLS-SOP-WQ-033 Rev 0 (adapted from APHA 5520C)	0.12	<0.1	<0.1	<0.1	<0.1	<0.1	<0.1	<0.1	<0.1	0.1	

Note:

1. APHA is a standard method for Determination of Water and Waste Water (APHA 23rd Edition, 2017)
2. "<" = Less than. The data reported is less than Detection Limit of the test.
3. "*" = The test was sub-contracted to external lab.

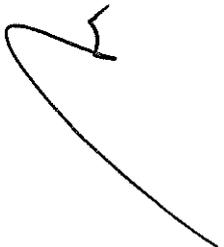

TEST REPORT

Our Reference No. : R222355
Project Code / Ref. : 60579645 Pulau Ubin Shoreline

Date Received : 07/04/2022
Date Commenced : 07/04/2022
Date Reported : 21/04/2022

Customer Ref. No. : -
Customer Name : AECOM Singapore Pte Ltd
Customer Address : 300 Beach Road
#03-00 The Concourse
Singapore 199555

Attention To : Ms Jacquelynn Chia
Sample Description : 10 Water samples as per received.

RESULTS : Refer to Page 2 to Page 3



Tan Thuan Piang
Technical Manager

Terms & Conditions:

- 1) This report shall not be reproduced except in full, unless approval in writing has been given by MLS.
- 2) The results in this report only apply to the sample received/analysed.
- 3) MLS agrees to use reasonable diligence in the performance of the service.

Marchwood Laboratory Services Pte Ltd:
Main (Office and Laboratory):
Branch (Site and Laboratory):
Website:

Co. Reg No. : 201422686C
116 Tuas South Ave 2, West Point Bizhub Singapore 637163
216 Tuas South Ave 2, West Point Bizhub Singapore 637213
www.mls.sg

 : +65 6790 0118
 : +65 6262 3736 (Lab)

 : +65 6790 0091
 : +65 6262 3726 / 3776 (Site)

R222355

RESULTS

Test Parameter	Unit	Test Method	Sample 1		Sample 2		Sample 3		Sample 4		Sample 5		LOR
			WQ1-SF 07/04/2022	7.4	WQ2-SF 07/04/2022	8.1	WQ3-SF 07/04/2022	8.1	WQ4-SF 07/04/2022	8.1	WQ5-SF 07/04/2022	8.1	
pH value	-	APHA 4500-H+ (B)	7.4	8.1	8.1	8.1	8.1	8.1	8.1	8.1	8.1	-	
Total Suspended Solids as TSS	mg/L	APHA 2540D	9.10	31.3	19.0	34.6	19.0	34.6	19.0	34.6	59.5	1	
Total Nitrogen as TN	mg/L	APHA 4500-P (J)	1.50	0.50	0.47	0.72	0.47	0.72	0.47	0.72	0.73	0.01	
Total Phosphorus as TP	mg/L	APHA 4500-P (J)	0.057	0.027	0.016	0.026	0.016	0.026	0.016	0.022	0.022	0.01	
Ammonia as NH ₄ -N	mg/L	APHA 4500-NH ₃ (H)	0.95	0.12	0.29	0.20	0.29	0.20	0.20	0.045	0.045	0.01	
Nitrate as NO ₃ -N	mg/L	APHA 4500-NO ₃ (I)	<0.005	0.038	0.030	0.035	0.030	0.035	0.035	0.045	0.045	0.005	
Nitrite as NO ₂ -N	mg/L	APHA 4500-NO ₃ (I)	<0.02	0.046	0.049	0.049	0.049	0.049	0.049	0.044	0.044	0.02	
Orthophosphates as PO ₄ -P	mg/L	APHA 4500-P (G)	0.054	0.014	0.012	0.013	0.012	0.013	0.013	0.014	0.014	0.005	
Biochemical Oxygen Demand as BOD	mg/L	APHA 5210B	1.07	<1	1.12	1.17	1.12	1.17	1.17	1.10	1.10	1	
Phenolic compounds as Phenols	mg/L	MLS-SOP-WQ-009 Rev 2	<0.025	<0.025	<0.025	<0.025	<0.025	<0.025	<0.025	<0.025	<0.025	0.025	
Cyanide as CN	mg/L	APHA 4500-CN- (N)	<0.005	<0.005	<0.005	<0.005	<0.005	<0.005	<0.005	<0.005	<0.005	0.005	
Arsenic as As	µg/L	APHA 3125B	2.84	2.42	2.36	2.34	2.36	2.34	2.34	2.28	2.28	0.5	
Cadmium as Cd	µg/L	APHA 3125B	<0.5	<0.5	<0.5	<0.5	<0.5	<0.5	<0.5	<0.5	<0.5	0.5	
Chromium as Cr (VI)	µg/L	APHA 3500-Cr (B)	<25	<25	<25	<25	<25	<25	<25	<25	<25	25	
Copper as Cu	µg/L	APHA 3125B	<0.5	0.58	0.65	0.62	0.65	0.62	0.62	0.67	0.67	0.5	
Mercury as Hg	µg/L	APHA 3125B	<0.1	<0.1	<0.1	<0.1	<0.1	<0.1	<0.1	<0.1	<0.1	0.1	
Nickel as Ni	µg/L	APHA 3125B	1.55	1.89	1.92	1.81	1.92	1.81	1.81	1.73	1.73	0.5	
Lead as Pb	µg/L	APHA 3125B	<0.5	<0.5	<0.5	<0.5	<0.5	<0.5	<0.5	<0.5	<0.5	0.5	
Zinc as Zn	µg/L	APHA 3125B	1.10	<0.5	<0.5	0.84	<0.5	0.84	<0.5	<0.5	<0.5	0.5	
Free Chlorine	mg/L	Lovibond Test Kit (DPD) Rev 1.0	<0.2	<0.2	<0.2	<0.2	<0.2	<0.2	<0.2	<0.2	<0.2	0.2	
Tributyltin*	ng/L	GC-MS	20	10	50	<10	50	<10	<10	10	10	10	
Faecal Coliform	MPN/100mL	APHA 9221E	220	94	34	58	34	58	58	70	70	2	
Enterococcus	cfu/100mL	APHA 9230C	160	26	94	62	94	62	62	92	92	1	
Oil & Grease (Total)	mg/L	In-house method MLS-SOP-WQ-033 Rev 0 (adapted from APHA 5520C)	0.16	<0.1	<0.1	<0.1	<0.1	<0.1	<0.1	<0.1	<0.1	0.1	

Note:

1. APHA is a standard method for Determination of Water and Waste Water (APHA 23rd Edition, 2017)
2. "<" = Less than. The data reported is less than Detection Limit of the test.
3. "*" = The test was sub-contracted to external lab.

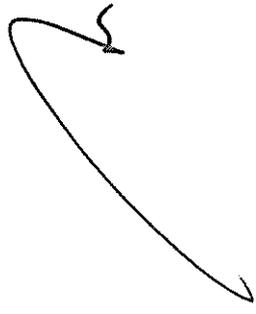

RESULTS

Test Parameter	Unit	Test Method	Sample 6		Sample 7		Sample 8		Sample 9		Sample 10		LOR
			WQ1-SE 07/04/2022	7.7	WQ2-SE 07/04/2022	8.1	WQ3-SE 07/04/2022	8.1	WQ4-SE 07/04/2022	8.1	WQ5-SE 07/04/2022	8.1	
pH value	-	APHA 4500-H+ (B)		7.7	8.1	8.1	8.1	8.1	8.1	8.1	8.1	8.1	-
Total Suspended Solids as TSS	mg/L	APHA 2540D	12.0	9.90	9.90	9.90	8.90	8.90	18.3	18.3	6.50	6.50	1
Total Nitrogen as TN	mg/L	APHA 4500-P (J)	0.66	0.60	0.60	0.60	0.58	0.58	0.78	0.78	0.55	0.55	0.01
Total Phosphorus as TP	mg/L	APHA 4500-P (J)	0.022	0.020	0.020	0.020	0.057	0.057	0.022	0.022	0.023	0.023	0.01
Ammonia as NH ₄ -N	mg/L	APHA 4500-NH ₃ (H)	0.21	0.016	0.016	0.016	0.025	0.025	0.018	0.018	0.020	0.020	0.01
Nitrate as NO ₃ -N	mg/L	APHA 4500-NO ₃ (I)	0.035	0.027	0.027	0.027	0.024	0.024	0.024	0.024	0.040	0.040	0.005
Nitrite as NO ₂ -N	mg/L	APHA 4500-NO ₃ (I)	0.036	0.042	0.042	0.042	0.041	0.041	0.039	0.039	0.044	0.044	0.02
Orthophosphates as PO ₄ -P	mg/L	APHA 4500-P (G)	0.019	0.010	0.010	0.010	0.011	0.011	0.0093	0.0093	0.012	0.012	0.005
Biochemical Oxygen Demand as BOD	mg/L	APHA 5210B	1.20	1.23	1.23	1.23	1.45	1.45	1.62	1.62	1.11	1.11	1
Phenolic compounds as Phenols	mg/L	MLS-SOP-WQ-009 Rev 2	<0.025	<0.025	<0.025	<0.025	<0.025	<0.025	<0.025	<0.025	<0.025	<0.025	0.025
Cyanide as CN	mg/L	APHA 4500-CN- (N)	<0.005	<0.005	<0.005	<0.005	<0.005	<0.005	<0.005	<0.005	<0.005	<0.005	0.005
Arsenic as As	µg/L	APHA 3125B	2.50	1.90	1.90	1.90	2.16	2.16	2.42	2.42	2.08	2.08	0.5
Cadmium as Cd	µg/L	APHA 3125B	<0.5	<0.5	<0.5	<0.5	<0.5	<0.5	<0.5	<0.5	<0.5	<0.5	0.5
Chromium as Cr (VI)	µg/L	APHA 3500-Cr (B)	<25	<25	<25	<25	<25	<25	<25	<25	<25	<25	25
Copper as Cu	µg/L	APHA 3125B	0.53	0.60	0.60	0.60	0.60	0.60	0.79	0.79	0.57	0.57	0.5
Mercury as Hg	µg/L	APHA 3125B	<0.1	<0.1	<0.1	<0.1	<0.1	<0.1	<0.1	<0.1	<0.1	<0.1	0.1
Nickel as Ni	µg/L	APHA 3125B	1.66	1.83	1.83	1.83	2.97	2.97	3.53	3.53	2.19	2.19	0.5
Lead as Pb	µg/L	APHA 3125B	<0.5	<0.5	<0.5	<0.5	<0.5	<0.5	<0.5	<0.5	<0.5	<0.5	0.5
Zinc as Zn	µg/L	APHA 3125B	1.02	0.76	0.76	0.76	<0.5	<0.5	<0.5	<0.5	<0.5	<0.5	0.5
Free Chlorine	mg/L	Lovibond Test Kit (DPD) Rev 1.0	<0.2	<0.2	<0.2	<0.2	<0.2	<0.2	<0.2	<0.2	<0.2	<0.2	0.2
Tributyltin*	ng/L	GC-MS	<10	<10	<10	<10	<10	<10	20	20	<10	<10	10
Faecal Coliform	MPN/100mL	APHA 9221E	540	70	70	70	79	79	170	170	150	150	2
Enterococcus	cfu/100mL	APHA 9230C	340	24	24	24	22	22	68	68	164	164	1
Oil & Grease (Total)	mg/L	In-house method MLS-SOP-WQ-033 Rev 0 (adapted from APHA 5520C)	<0.1	<0.1	<0.1	<0.1	<0.1	<0.1	<0.1	<0.1	<0.1	<0.1	0.1

Note:

1. APHA is a standard method for Determination of Water and Waste Water (APHA 23rd Edition, 2017)
2. "<" = Less than. The data reported is less than Detection Limit of the test.
3. "*" = The test was sub-contracted to external lab.

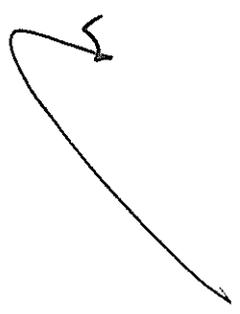

TEST REPORT

Our Reference No. : R223914
Project Code / Ref. : 60579645

Date Received : 10/06/2022
Date Commenced : 10/06/2022
Date Reported : 27/06/2022

Customer Ref. No. : -
Customer Name : AECOM Singapore Pte Ltd
Customer Address : 300 Beach Road
#03-00 The Concourse
Singapore 199555

Attention To : Dr. Nguyen Hoai Thanh
Sample Description : 2 Water samples as per received.

RESULTS : Refer to Page 2

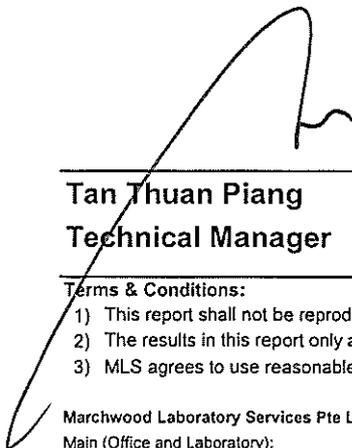

Tan Thuan Piang
Technical Manager

Terms & Conditions:

- 1) This report shall not be reproduced except in full, unless approval in writing has been given by MLS.
- 2) The results in this report only apply to the sample received/analysed.
- 3) MLS agrees to use reasonable diligence in the performance of the service.

Marchwood Laboratory Services Pte Ltd:
Main (Office and Laboratory):
Branch (Site and Laboratory):
Website:

Co. Reg No. : 201422686C
116 Tuas South Ave 2, West Point Bizhub Singapore 637163
216 Tuas South Ave 2, West Point Bizhub Singapore 637213
www.mls.sg

 : +65 6790 0118
 : +65 6262 3736 (Lab)

 : +65 6790 0091
 : +65 6262 3726 / 3776 (Site)

R223914

RESULTS

Test Parameter	Unit	Test Method	Sample 1	Sample 2	LOR
			WQ6-NF 10/06/2022	WQ6-NE 10/06/2022	
Total Nitrogen as TN	mg/L	APHA 4500-P (J)	0.59	0.47	0.01
Total Phosphorus as TP	mg/L	APHA 4500-P (J)	0.055	0.026	0.01
Ammonia as NH ₄ -N	mg/L	APHA 4500-NH ₃ (H)	0.012	<0.01	0.01
Nitrate as NO ₃ -N	mg/L	APHA 4500-NO ₃ (I)	0.0082	0.0067	0.005
Nitrite as NO ₂ -N	mg/L	APHA 4500-NO ₃ (I)	<0.02	<0.02	0.02
Orthophosphates as PO ₄ -P	mg/L	APHA 4500-P (G)	0.0073	0.0059	0.005
Total Suspended Solids as TSS	mg/L	APHA 2540D	10.2	11.0	1
Faecal coliform	MPN/100mL	APHA 9221E	63	6	2
Enterococcus	cfu/100mL	APHA 9230C	<1	<1	1
Lead as Pb	µg/L	APHA 3125B	<0.5	<0.5	0.5
Biochemical Oxygen Demand as BOD	mg/L	APHA 5210B	<1	<1	1
Oil & Grease (Total)	mg/L	In-house method MLS-SOP-WQ-033 Rev 0 (adapted from APHA 5520C)	<0.1	<0.1	0.1
Copper as Cu	µg/L	APHA 3125B	0.76	0.86	0.5
Zinc as Zn	µg/L	APHA 3125B	<0.5	<0.5	0.5
Mercury as Hg	µg/L	APHA 3125B	<0.1	<0.1	0.1
Cadmium as Cd	µg/L	APHA 3125B	<0.5	<0.5	0.5
Chromium as Cr (VI)	µg/L	APHA 3500-Cr (B)	<25	<25	25
Nickel as Ni	µg/L	APHA 3125B	1.18	1.27	0.5
Arsenic as As	µg/L	APHA 3125B	2.36	2.19	0.5
Cyanide as CN	mg/L	APHA 4500-CN- (N)	<0.005	<0.005	0.005
Free Chlorine	mg/L	Lovibond Test Kit (DPD) Rev 1.0	<0.2	<0.2	0.2
Tributyltin*	ng/L	GC-MS	30.0	<10	10
Phenolic compounds as Phenols	mg/L	MLS-SOP-WQ-009 Rev 2	<0.025	<0.025	0.025

Note:

1. APHA is a standard method for Determination of Water and Waste Water (APHA 23rd Edition, 2017)
2. "<" = Less than. The data reported is less than Detection Limit of the test.
3. "*" = The test was sub-contracted to external lab.

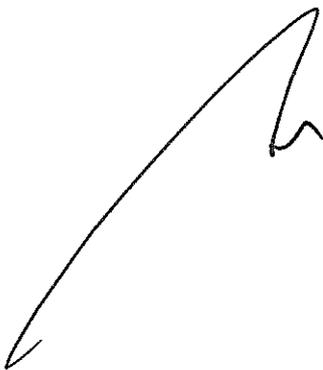

TEST REPORT

Our Reference No. : R224015
Project Code / Ref. : 60579645

Date Received : 15/06/2022
Date Commenced : 15/06/2022
Date Reported : 28/06/2022

Customer Ref. No. : -
Customer Name : AECOM Singapore Pte Ltd
Customer Address : 300 Beach Road
#03-00 The Concourse
Singapore 199555

Attention To : Dr. Nguyen Hoai Thanh
Sample Description : 2 Water samples as per received.

RESULTS : Refer to Page 2



Tan Thuan Piang
Technical Manager

Terms & Conditions:

- 1) This report shall not be reproduced except in full, unless approval in writing has been given by MLS.
- 2) The results in this report only apply to the sample received/analysed.
- 3) MLS agrees to use reasonable diligence in the performance of the service.

Marchwood Laboratory Services Pte Ltd:
Main (Office and Laboratory):
Branch (Site and Laboratory):
Website:

Co. Reg No. : 201422686C
116 Tuas South Ave 2, West Point Bizhub Singapore 637163
216 Tuas South Ave 2, West Point Bizhub Singapore 637213
www.mls.sg

 : +65 6790 0118
 : +65 6262 3736 (Lab)

 : +65 6790 0091
 : +65 6262 3726 / 3776 (Site)

R224015

RESULTS

Test Parameter	Unit	Test Method	Sample 1	Sample 2	LOR
			WQ6-SF 15/06/2022	WQ6-SE 15/06/2022	
Total Nitrogen as TN	mg/L	APHA 4500-P (J)	0.41	0.34	0.01
Total Phosphorus as TP	mg/L	APHA 4500-P (J)	0.019	0.029	0.01
Ammonia as NH ₄ -N	mg/L	APHA 4500-NH ₃ (H)	0.064	0.049	0.01
Nitrate as NO ₃ -N	mg/L	APHA 4500-NO ₃ (I)	0.062	0.054	0.005
Nitrite as NO ₂ -N	mg/L	APHA 4500-NO ₃ (I)	0.025	0.025	0.02
Orthophosphates as PO ₄ -P	mg/L	APHA 4500-P (G)	0.015	0.015	0.005
Total Suspended Solids as TSS	mg/L	APHA 2540D	7.30	5.70	1
Faecal coliform	MPN/100mL	APHA 9221E	11	2	2
Enterococcus	cfu/100mL	APHA 9230C	4	4	1
Lead as Pb	µg/L	APHA 3125B	<0.5	<0.5	0.5
Biochemical Oxygen Demand as BOD	mg/L	APHA 5210B	<1	<1	1
Oil & Grease (Total)	mg/L	In-house method MLS-SOP-WQ-033 Rev 0 (adapted from APHA 5520C)	<0.1	<0.1	0.1
Copper as Cu	µg/L	APHA 3125B	1.16	1.07	0.5
Zinc as Zn	µg/L	APHA 3125B	2.54	<0.5	0.5
Mercury as Hg	µg/L	APHA 3125B	<0.1	<0.1	0.1
Cadmium as Cd	µg/L	APHA 3125B	<0.5	<0.5	0.5
Chromium as Cr (VI)	µg/L	APHA 3500-Cr (B)	<25	<25	25
Nickel as Ni	µg/L	APHA 3125B	3.22	2.23	0.5
Arsenic as As	µg/L	APHA 3125B	2.96	2.92	0.5
Cyanide as CN	mg/L	APHA 4500-CN- (N)	<0.005	<0.005	0.005
Free Chlorine	mg/L	Lovibond Test Kit (DPD) Rev 1.0	<0.2	<0.2	0.2
Tributyltin*	ng/L	GC-MS	40.0	<10	10
Phenolic compounds as Phenols	mg/L	MLS-SOP-WQ-009 Rev 2	<0.025	<0.025	0.025

Note:

1. APHA is a standard method for Determination of Water and Waste Water (APHA 23rd Edition, 2017)
2. "<" = Less than. The data reported is less than Detection Limit of the test.
3. "*" = The test was sub-contracted to external lab.

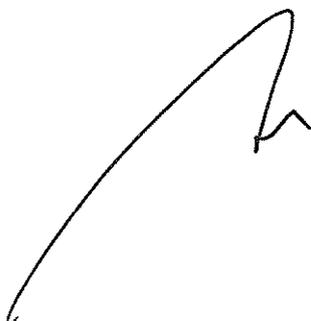

TEST REPORT

Our Reference No. : **R215469/1**
Project Code / Ref. : Marine Shoreline Project at Pulau Ubin

Date Received : 07/10/2021
Date Commenced : 07/10/2021
Date Reported : 21/10/2021

Customer Ref. No. : -
Customer Name : AECOM Singapore Pte Ltd
Customer Address : 300 Beach Road
#03-00 The Concourse
Singapore 199555

Attention To : Mr. Chan Eu Jin
Sample Description : 3 Soil Samples as per received

RESULTS: Refer to Page 2

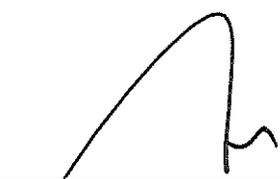

Tan Thuan Piang
Technical Manager

Terms & Conditions:

- 1) This report shall not be reproduced except in full, unless approval in writing has been given by MLS.
- 2) The results in this report only apply to the sample received/analysed.
- 3) MLS agrees to use reasonable diligence in the performance of the service.

Marchwood Laboratory Services Pte Ltd:
Main (Office and Laboratory):
Branch (Site and Laboratory):
Website:

Co. Reg No. : 201422686C
116 Tuas South Ave 2, West Point Bizhub Singapore 637163
216 Tuas South Ave 2, West Point Bizhub Singapore 637213
www.mls.sg

 : +65 6790 0118
 : +65 6262 3736 (Lab)

 : +65 6790 0091
 : +65 6262 3726 / 3776 (Site)

R215469/1

RESULTS:

Test Parameter	Test Method	Unit	S2	S4	S7
			28/09/2021	28/09/2021	28/09/2021
Arsenic as As	USEPA 3051A / APHA 3120B	mg/kg	15.5	13.6	17.2
Cadmium as Cd	USEPA 3051A / APHA 3120B	mg/kg	0.42	0.44	0.36
Chromium as Cr	USEPA 3051A / APHA 3120B	mg/kg	21.5	17.0	22.6
Copper as Cu	USEPA 3051A / APHA 3120B	mg/kg	19.2	13.8	15.2
Nickel as Ni	USEPA 3051A / APHA 3120B	mg/kg	12.5	10.1	9.62
Lead as Pb	USEPA 3051A / APHA 3120B	mg/kg	22.6	15.6	20.2
Zinc as Zn	USEPA 3051A / APHA 3120B	mg/kg	70.3	54.4	46.2
Mercury as Hg	USEPA 3051A / USEPA 245.1 (FIMS) (1994)	mg/kg	0.069	0.046	0.059
Moisture Content	BS 1377-2: 1990	%	55.9	37.3	56.2
Potassium as K (% by dry mass)	USEPA 3051A / APHA 3120B	%	0.26	0.17	0.23
Total Phosphorus as P (% by dry mass)	USEPA 3051A / APHA 3120B	%	0.054	0.044	0.043
Total Nitrogen as N (% by dry mass)	APHA 4500-Norg (D) / APHA 4500-NO ₃ (I)	%	0.22	0.16	0.25
Cation Exchange Capacity*	In-House Method based on USEPA 9080	meq/100g Sodium	7.37	15.8	6.22
Bulk Density	BS 1377:1990 Section 7.2	Mg/m ³	1.37	1.54	1.34
Faecal coliform	FDA-BAM Chapter 4: Jul 2017	MPN/100mL	<3	3.6	3.6
E.coli	FDA-BAM Chapter 4: Jul 2017	MPN/100mL	<3	3.6	<3
Total Petroleum Hydrocarbon	USEPA 8440 (1996)	mg/kg	<10	<10	<10

Note:

1. APHA is a standard method for Determination of Water and Waste Water (APHA 23rd Edition, 2017).
2. "<" = less than. The result was less than the detection limit.
3. Results are based on dry weight.
4. "*" = The above test were subcontracted to external lab.

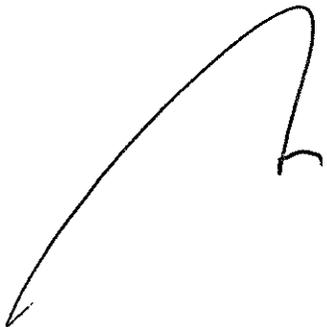

TEST REPORT

Our Reference No. : R215469/2
Project Code / Ref. : Marine Shoreline Project at Pulau Ubin

Date Received : 07/10/2021
Date Commenced : 07/10/2021
Date Reported : 25/10/2021

Customer Ref. No. : -
Customer Name : AECOM Singapore Pte Ltd
Customer Address : 300 Beach Road
#03-00 The Concourse
Singapore 199555

Attention To : Mr. Chan Eu Jin
Sample Description : 3 Soil Samples as per received
Test Parameter : Particle Size Distribution
Test Method : BS 1377:1990 Part 2

RESULTS: Refer to Page 2 to 7



Tan Thuan Piang
Technical Manager

Terms & Conditions:

- 1) This report shall not be reproduced except in full, unless approval in writing has been given by MLS.
- 2) The results in this report only apply to the sample received/analysed.
- 3) MLS agrees to use reasonable diligence in the performance of the service.

Marchwood Laboratory Services Pte Ltd:
Main (Office and Laboratory):
Branch (Site and Laboratory):
Website:

Co. Reg No. : 201422686C
116 Tuas South Ave 2, West Point Bizhub Singapore 637163
216 Tuas South Ave 2, West Point Bizhub Singapore 637213
www.mls.sg

 : +65 6790 0118
 : +65 6262 3736 (Lab)

 : +65 6790 0091
 : +65 6262 3726 / 3776 (Site)

R215469/2

RESULTS

Sample ID - GS#1 S2

Particle Size Distribution

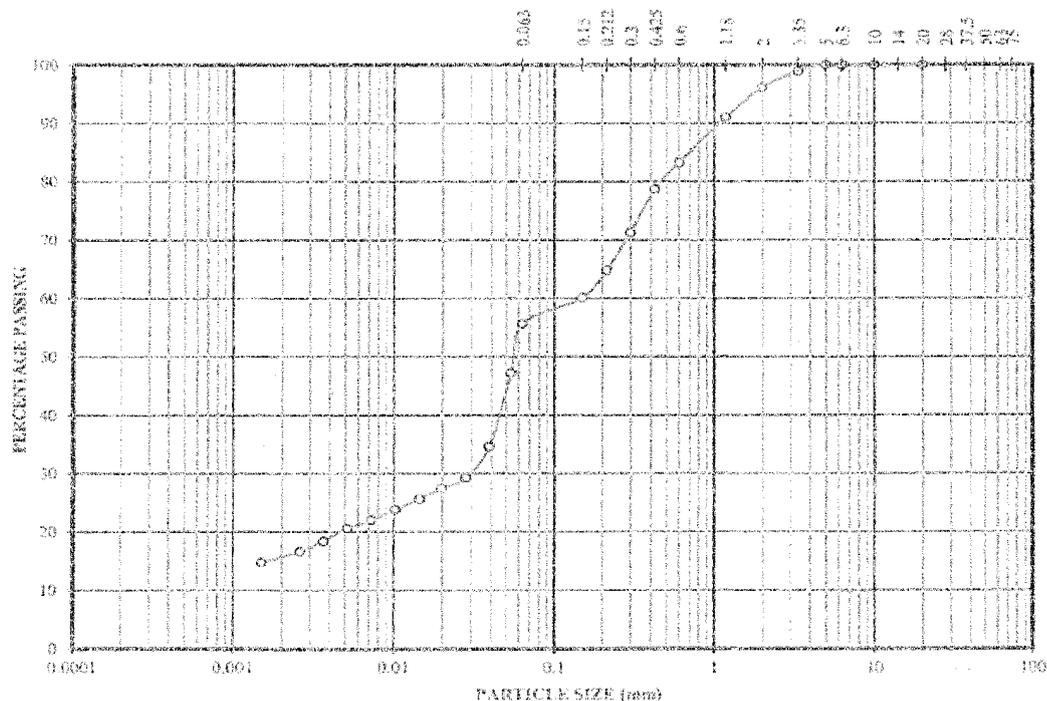

CLAY	SILT			SAND			GRAVEL		
	FINE	MEDIUM	COARSE	FINE	MEDIUM	COARSE	FINE	MEDIUM	COARSE

SAMPLE NO	DEPTH (m)	GRAVEL %	SAND %	SILT %	CLAY %	SAMPLE DESCRIPTION
Grab Sample 1		4	40	40	15	Dark greenish grey slightly gravelly Sandy SILT with traces of shell fragments

Note:
1. Above test was subcontracted to external lab.

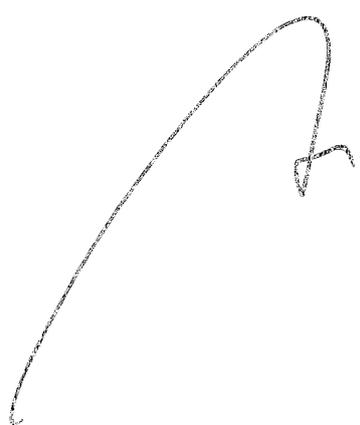

R215469/2

RESULTS

Sample ID - GS#2 S4

Particle Size Distribution

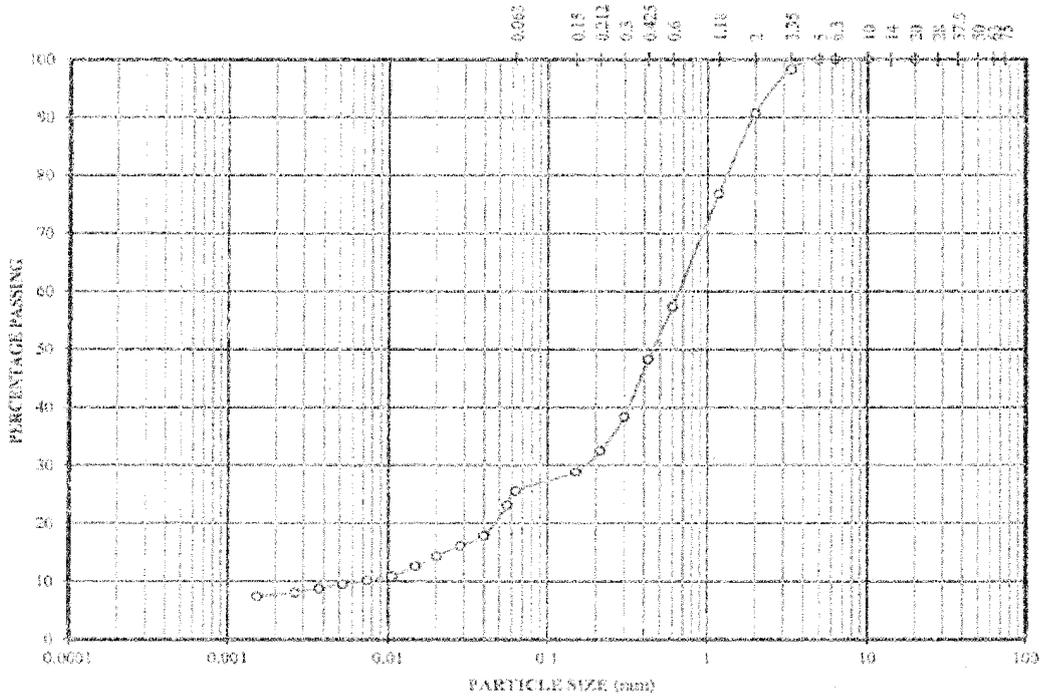

CLAY	SILT			SAND			GRAVEL		
	FINE	MEDIUM	COARSE	FINE	MEDIUM	COARSE	FINE	MEDIUM	COARSE

SAMPLE NO	DEPTH (m)	GRAVEL %	SAND %	SILT %	CLAY %	SAMPLE DESCRIPTION

Note:
1. Above test was subcontracted to external lab.



R215469/2

RESULTS
Sample ID - GS#3

Particle Size Distribution S7

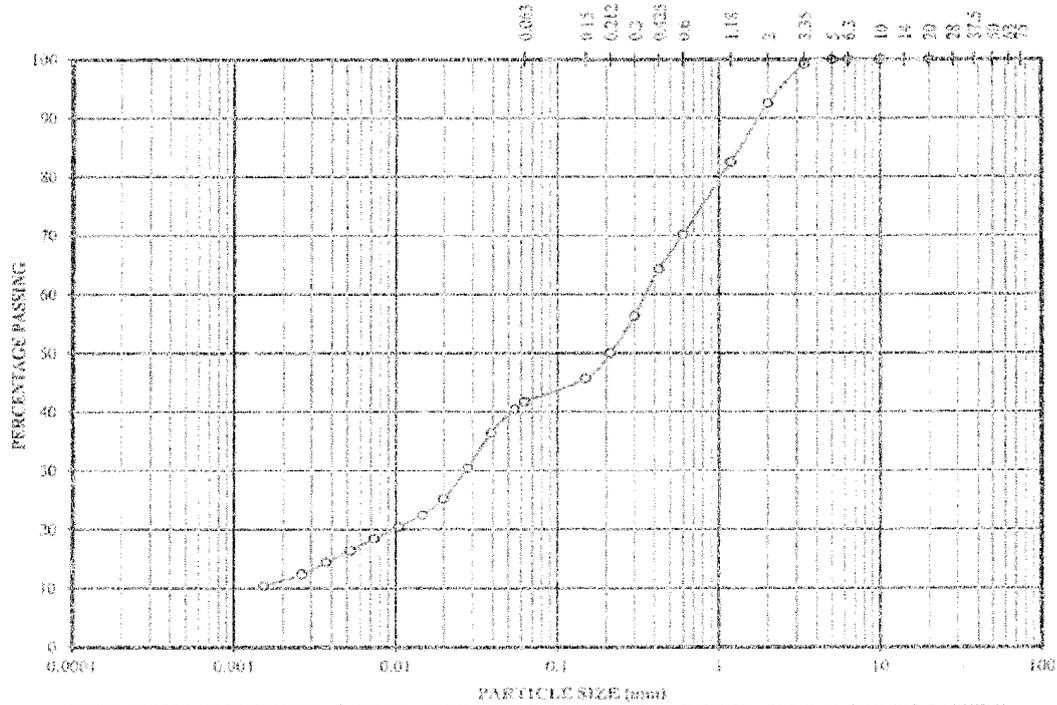

	FINE	MEDIUM	COARSE	FINE	MEDIUM	COARSE	FINE	MEDIUM	COARSE
CLAY	SILT			SAND			GRAVEL		

SAMPLE NO	DEPTH (m)	GRAVEL %	SAND %	SILT %	CLAY %	SAMPLE DESCRIPTION
GS#3 Sample 3	-	7	51	31	11	Dark greenish grey slightly gravelly Sandy SILT with traces of shell fragments

Note:
1. Above test was subcontracted to external lab.

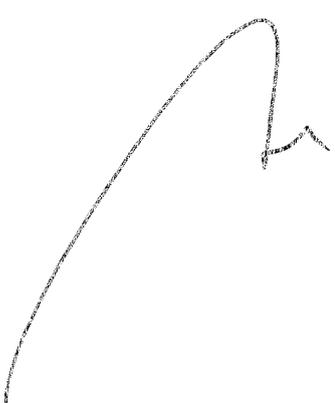

R215469/2

RESULTS

Particle Density

Particle Density, ρ_s
 Small Pycnometer Method
 BS 1377 : Part 2 : 1990 : 8.3
 (Specific Gravity)

Project : R215469

Description of Soil : Dark greenish grey slightly gravelly Sandy SILT with traces of shell fragments

Borehole No : - Sample No : Grab Sample 1 Depth (m) : -

S2

Test No :	1	2
ρ_s Bottle No :	A1	A2
Mass of ρ_s bottle with stopper, M1 (gm)	33.180	32.969
Mass of ρ_s bottle with Stopper & Soil, M2 (gm)	39.321	39.147
Mass of ρ_s bottle with Stopper, Soil & Distilled Water, M3 (gm)	90.183	89.796
Mass of ρ_s bottle with Stopper & Distilled Water, M4 (gm)	86.341	85.935
$\rho_s = \frac{(M2 - M1)}{(M4 - M1) - (M3 - M2)}$	2.671	2.666

Average Particle Density, ρ_s (Mg/m^3) : 2.67

Note:

1. Above test was subcontracted to external accredited lab.



R215469/2

RESULTS

Particle Density

Particle Density, ρ_s
 Small Pycnometer Method
 BS 1377 : Part 2 : 1990 : 8.3
 (Specific Gravity)

Project : R215469

Description of Soil : Dark greenish grey gravelly Silty SAND with traces of shell fragments

Borehole No : Sample No : Grab Sample 2 Depth (m) :

S4

Test No :	1	2
ρ_s Bottle No :	A3	A4
Mass of ρ_s bottle with stopper, M1 (gm)	32.131	33.182
Mass of ρ_s bottle with Stopper & Soil, M2 (gm)	38.412	39.352
Mass of ρ_s bottle with Stopper, Soil & Distilled Water, M3 (gm)	88.476	88.905
Mass of ρ_s bottle with Stopper & Distilled Water, M4 (gm)	84.561	85.054
$\rho_s = \frac{(M2 - M1)}{(M4 - M1) - (M3 - M2)}$	2.655	2.661

Average Particle Density, ρ_s (Mg/m^3) : 2.66

Note:

1. Above test was subcontracted to external accredited lab.



R215469/2

RESULTS

Particle Density

Particle Density, ρ_s
 Small Pycnometer Method
 BS 1377 : Part 2 : 1990 : 8.3
 (Specific Gravity)

Project : R215469

Description of Soil : Dark greenish grey slightly gravelly Sandy SILT with traces of shell fragments

Borehole No : - Sample No : Grab Sample 3 Depth (m) : -

S7

Test No :	1	2
ρ_s Bottle No :	A5	A6
Mass of ρ_s bottle with stopper, M1 (gm)	32.414	31.949
Mass of ρ_s bottle with Stopper & Soil, M2 (gm)	38.618	38.453
Mass of ρ_s bottle with Stopper, Soil & Distilled Water, M3 (gm)	90.396	89.745
Mass of ρ_s bottle with Stopper & Distilled Water, M4 (gm)	96.510	85.667
$\rho_s = \frac{(M2 - M1)}{(M4 - M1) - (M3 - M2)}$	2.676	2.681

Average Particle Density, ρ_s (Mg/m^3) : 2.68

Note:

1. Above test was subcontracted to external accredited lab.

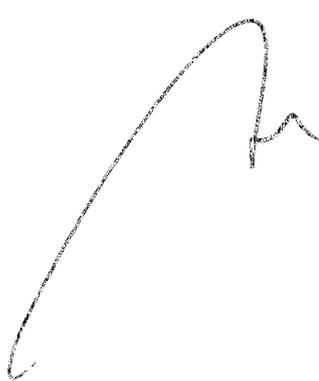

TEST REPORT

Our Reference No. : **R216958/1**
Project Code / Ref. : Pulau Ubin Mangrove Restoration Works

Date Received : 15/12/2021
Date Commenced : 15/12/2021
Date Reported : 28/12/2021

Customer Ref. No. : 60579645
Customer Name : AECOM Singapore Pte Ltd
Customer Address : 300 Beach Road
#23-00 The Concourse
Singapore 199555

Attention To : Ms Beh Yoong Yoong
Sample Description : 1 Sludge Sample as per received

RESULTS: Refer to Page 2



Tan Thuan Piang
Technical Manager

Terms & Conditions:

- 1) This report shall not be reproduced except in full, unless approval in writing has been given by MLS.
- 2) The results in this report only apply to the sample received/analysed.
- 3) MLS agrees to use reasonable diligence in the performance of the service.

Marchwood Laboratory Services Pte Ltd:
Main (Office and Laboratory):
Branch (Site and Laboratory):
Website:

Co. Reg No. : 201422686C
116 Tuas South Ave 2, West Point Bizhub Singapore 637163
216 Tuas South Ave 2, West Point Bizhub Singapore 637213
www.mls.sg

 : +65 6790 0118
 : +65 6262 3736 (Lab)

 : +65 6790 0091
 : +65 6262 3726 / 3776 (Site)

R216958/1

RESULTS:

Test Parameter	Test Method	Unit	Sampling Date: 15/12/2021
			S1
			1200hrs
			GS 4
Arsenic as As	USEPA 3051A / APHA 3120B	mg/kg	30.5
Cadmium as Cd	USEPA 3051A / APHA 3120B	mg/kg	0.67
Chromium as Cr	USEPA 3051A / APHA 3120B	mg/kg	21.2
Copper as Cu	USEPA 3051A / APHA 3120B	mg/kg	15.3
Nickel as Ni	USEPA 3051A / APHA 3120B	mg/kg	5.62
Lead as Pb	USEPA 3051A / APHA 3120B	mg/kg	25.5
Zinc as Zn	USEPA 3051A / APHA 3120B	mg/kg	54.0
Mercury as Hg	USEPA 3051A / USEPA 245.1 (FIMS) (1994)	mg/kg	0.13
Moisture Content	BS 1377-2: 1990	%	61.6
Potassium as K (% by dry mass)	USEPA 3051A / APHA 3120B	%	0.14
Total Phosphorus as P (% by dry mass)	USEPA 3051A / APHA 3120B	%	0.065
Total Nitrogen as N (% by dry mass)	APHA 4500-Norg (D) /APHA 4500-NO ₃ (I)	%	0.24
Cation Exchange Capacity*	In-House Method based on USEPA 9080	meq/100g Sodium	20.7
Bulk Density	BS 1377:1990 Section 7.2	Mg/m ³	1.30
Faecal coliform	FDA-BAM: Chapter 4: Oct 2020	MPN/g	<3
E.coli	FDA-BAM: Chapter 4: Oct 2020	MPN/g	<3
Total Petroleum Hydrocarbon	USEPA 8440 (1996)	mg/kg	<10

Note:

1. APHA is a standard method for Determination of Water and Waste Water (APHA 23rd Edition, 2017).
2. "<" = less than. The result was less than the detection limit.
3. Results are based on dry weight.
4. "*" = The above test were subcontracted to external lab.

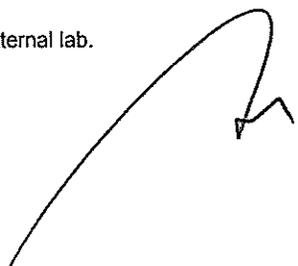

TEST REPORT

Our Reference No. : **R216958/2**
Project Code / Ref. : Pulau Ubin Mangrove Restoration Works

Date Received : 15/12/2021
Date Commenced : 15/12/2021
Date Reported : 28/12/2021

Customer Ref. No. : -
Customer Name : AECOM Singapore Pte Ltd
Customer Address : 300 Beach Road
#23-00 The Concourse
Singapore 199555

Attention To : Ms Beh Yoong Yoong
Sample Description : 1 Sludge Sample as per received
Test Parameter : Particle Size Distribution
Test Method : BS 1377:1990 Part 2

RESULTS: Refer to Page 2 to 3

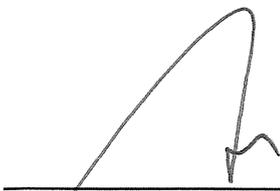

Tan Thuan Piang
Technical Manager

Terms & Conditions:

- 1) This report shall not be reproduced except in full, unless approval in writing has been given by MLS.
- 2) The results in this report only apply to the sample received/analysed.
- 3) MLS agrees to use reasonable diligence in the performance of the service.

Marchwood Laboratory Services Pte Ltd:

Co. Reg No. : 201422686C

Main (Office and Laboratory):

116 Tuas South Ave 2, West Point Bizhub Singapore 637163

Branch (Site and Laboratory):

216 Tuas South Ave 2, West Point Bizhub Singapore 637213

Website:

www.mls.sg

 : +65 6790 0118

 : +65 6262 3736 (Lab)

 : +65 6790 0091

 : +65 6262 3726 / 3776 (Site)

R216958/2

RESULTS
Sample ID - GS 4 S1

Particle Size Distribution

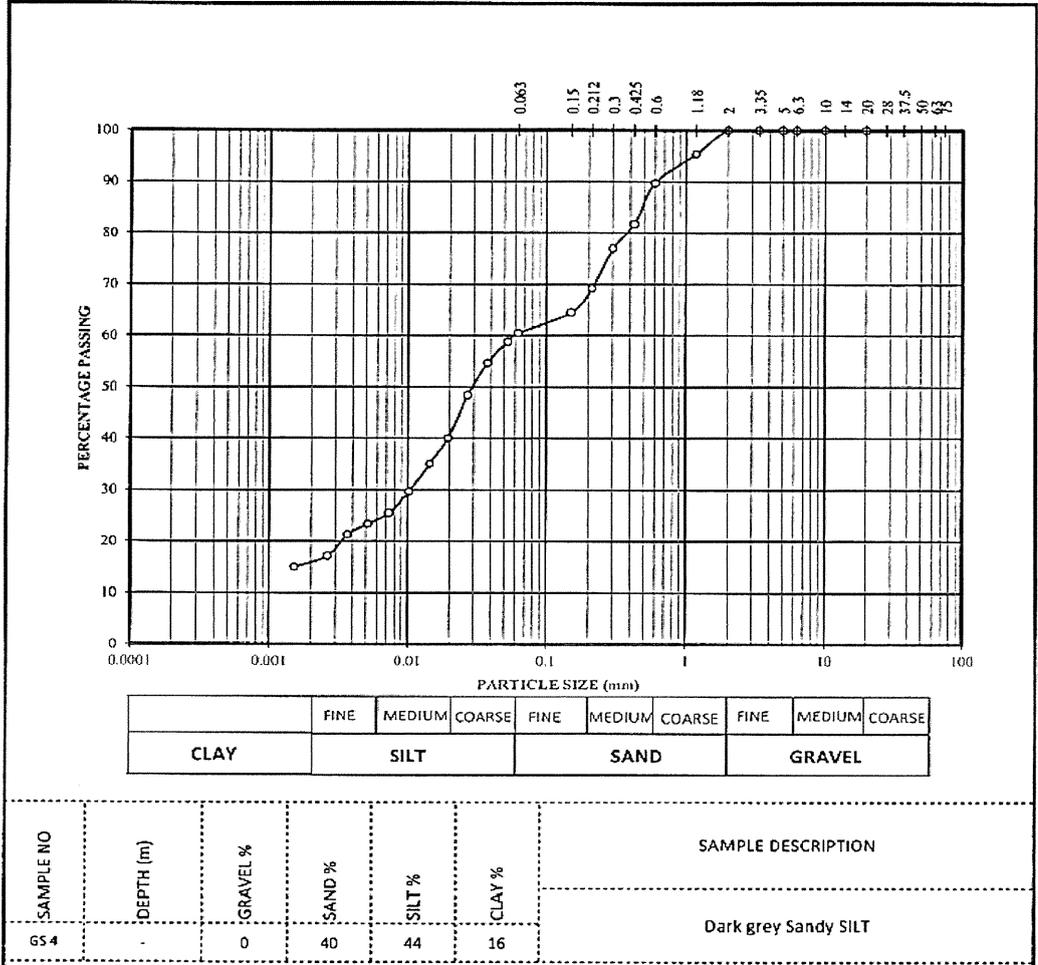

Note:
1. Above test was subcontracted to external lab.

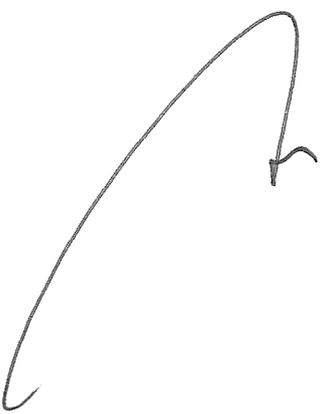

R216958/2

RESULTS

Particle Density

Particle Density, ρ_s
 Small Pycnometer Method
 BS 1377 : Part 2 : 1990 : 8.3
 (Specific Gravity)

Project : R216958

Description of Soil : Dark grey Sandy SILT

Borehole No: - Sample No: GS 4 Depth (m) : -

S1

Test No :	1	2
ρ_s Bottle No :	A1	A2
Mass of ρ_s bottle with stopper, M1 (gm)	33.180	32.969
Mass of ρ_s bottle with Stopper & Soil, M2 (gm)	39.418	39.227
Mass of ρ_s bottle with Stopper, Soil & Distilled Water, M3 (gm)	90.253	89.855
Mass of ρ_s bottle with Stopper & Distilled Water, M4 (gm)	86.341	85.935
$\rho_s = \frac{(M2 - M1)}{(M4 - M1) - (M3 - M2)}$	2.682	2.677

Average Particle Density, ρ_s (Mg/m^3) : 2.68

Note:

- Above test was subcontracted to external accredited lab.



TEST REPORT

Our Reference No. : **R221584/2A**
Project Code / Ref. : 60579645 Pulau Ubin Shoreline

Date Received : 10/03/2022
Date Commenced : 10/03/2022
Date Reported : 23/03/2022

Customer Ref. No. : -
Customer Name : AECOM Singapore Pte Ltd
Customer Address : 300 Beach Road
#03-00 The Concourse
Singapore 199555

Attention To : Ms Jacquelynn Chia
Sample Description : 4 Sediment Samples as per received

RESULTS: Refer to Page 2



Tan Thuan Piang
Technical Manager

Terms & Conditions:

- 1) This report shall not be reproduced except in full, unless approval in writing has been given by MLS.
- 2) The results in this report only apply to the sample received/analysed.
- 3) MLS agrees to use reasonable diligence in the performance of the service.

Marchwood Laboratory Services Pte Ltd:
Main (Office and Laboratory):
Branch (Site and Laboratory):
Website:

Co. Reg No. : 201422686C
116 Tuas South Ave 2, West Point Bizhub Singapore 637163
216 Tuas South Ave 2, West Point Bizhub Singapore 637213
www.mls.sg

 : +65 6790 0118
 : +65 6262 3736 (Lab)

 : +65 6790 0091
 : +65 6262 3726 / 3776 (Site)

R221584/2A

RESULTS:

Test Parameter	Test Method	Unit	Sampling Date: 09/03/2022			
			S3	S5	S6	S8
Arsenic as As	USEPA 3051A / APHA 3120B	mg/kg	18.1	17.4	14.0	13.3
Cadmium as Cd	USEPA 3051A / APHA 3120B	mg/kg	0.49	0.53	0.42	0.31
Chromium as Cr	USEPA 3051A / APHA 3120B	mg/kg	21.4	23.1	21.8	9.25
Copper as Cu	USEPA 3051A / APHA 3120B	mg/kg	19.1	20.0	19.0	7.74
Nickel as Ni	USEPA 3051A / APHA 3120B	mg/kg	12.8	14.2	12.9	4.61
Lead as Pb	USEPA 3051A / APHA 3120B	mg/kg	24.4	25.3	25.9	11.1
Zinc as Zn	USEPA 3051A / APHA 3120B	mg/kg	67.2	75.5	68.4	33.5
Mercury as Hg	USEPA 3051A / USEPA 245.1 (FIMS) (1994)	mg/kg	0.21	0.19	0.15	0.074
Total Phosphorus as P (% by dry mass)	USEPA 3051A / APHA 3120B	%	0.010	0.011	0.011	0.0084
Total Nitrogen as N (% by dry mass)	APHA 4500-Norg (D) / APHA 4500-NO ₃ (I)	%	0.22	0.22	0.21	0.098
Total Petroleum Hydrocarbon	USEPA 8440 (1996)	mg/kg	<0.1	<0.1	<0.1	<0.1

Note:

1. APHA is a standard method for Determination of Water and Waste Water (APHA 23rd Edition, 2017).
2. "<" = less than. The result was less than the detection limit.
3. Results are based on dry weight.

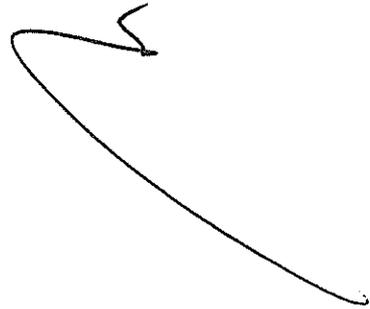

TEST REPORT

Our Reference No. : **R221584/2B**
Project Code / Ref. : 60579645 Pulau Ubin Shoreline

Date Received : 10/03/2022
Date Commenced : 10/03/2022
Date Reported : 23/03/2022

Customer Ref. No. : -
Customer Name : AECOM Singapore Pte Ltd
Customer Address : 300 Beach Road
#03-00 The Concourse
Singapore 199555

Attention To : Ms Jacquelynn Chia
Sample Description : 4 Sediment Samples as per received
Test Parameter : Particle Size Distribution
Test Method : BS 1377:1990 Part 2

RESULTS: Refer to Page 2 to Page 5

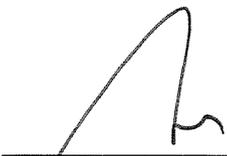

Tan Thuan Piang
Technical Manager

Terms & Conditions:

- 1) This report shall not be reproduced except in full, unless approval in writing has been given by MLS.
- 2) The results in this report only apply to the sample received/analysed.
- 3) MLS agrees to use reasonable diligence in the performance of the service.

Marchwood Laboratory Services Pte Ltd:
Main (Office and Laboratory):
Branch (Site and Laboratory):
Website:

Co. Reg No. : 201422686C
116 Tuas South Ave 2, West Point Bizhub Singapore 637163
216 Tuas South Ave 2, West Point Bizhub Singapore 637213
www.mls.sg

 : +65 6790 0118
 : +65 6262 3736 (Lab)

 : +65 6790 0091
 : +65 6262 3726 / 3776 (Site)

R221584/2B

RESULTS

Test Method - BS 1377:1990-PART 2

Particle Size Distribution

Sample ID - Sample 1 - S3

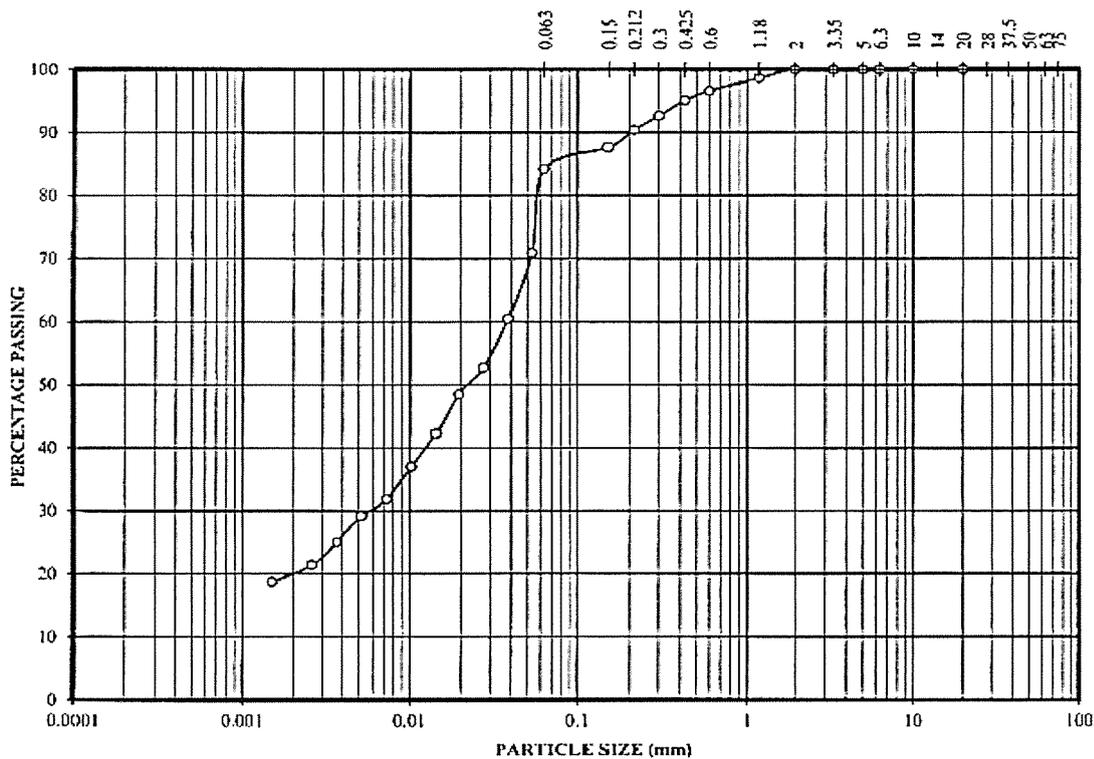

	FINE	MEDIUM	COARSE	FINE	MEDIUM	COARSE	FINE	MEDIUM	COARSE
CLAY	SILT			SAND			GRAVEL		

SAMPLE NO	DEPTH (m)	GRAVEL %	SAND %	SILT %	CLAY %	SAMPLE DESCRIPTION
						Dark greenish grey slightly Sandy SILT

Note:

1. Above test was subcontracted to external accredited lab.

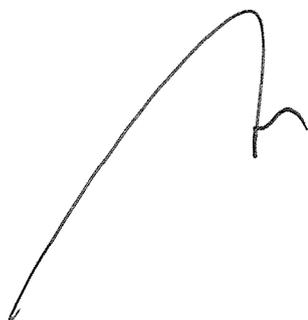

R221584/2B

RESULTS

Test Method - BS 1377:1990-PART 2

Particle Size Distribution

Sample ID - Sample 2 - S5

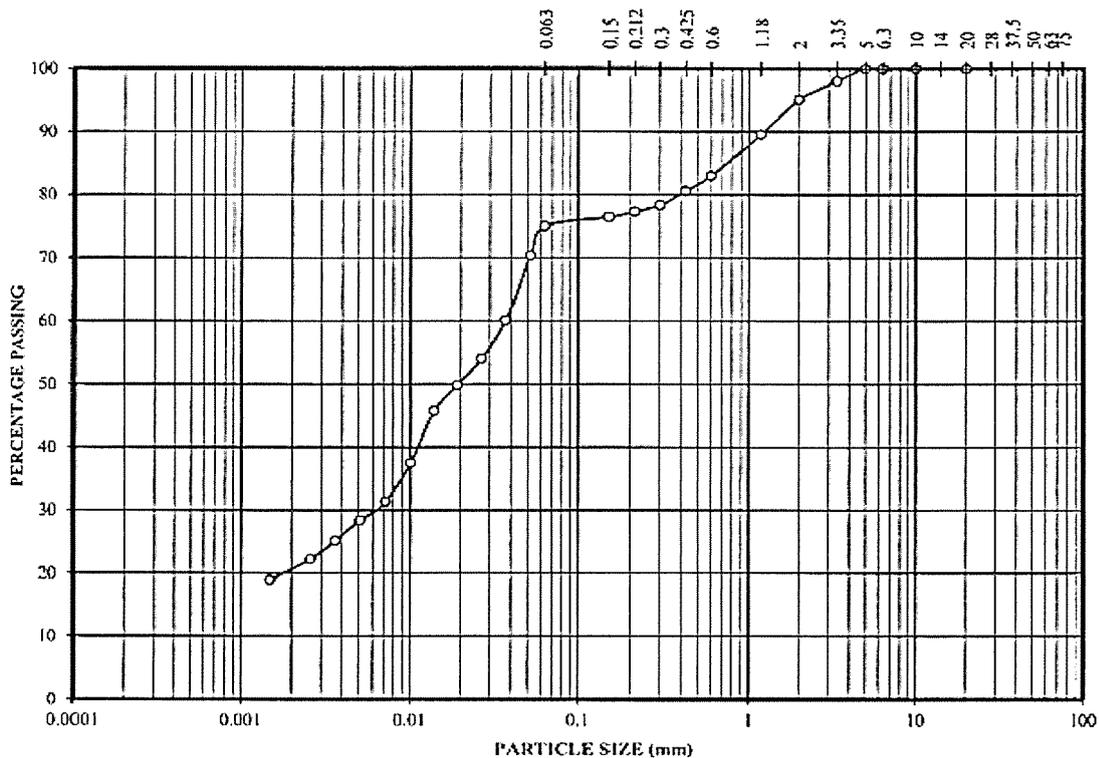

	FINE	MEDIUM	COARSE	FINE	MEDIUM	COARSE	FINE	MEDIUM	COARSE
CLAY	SILT			SAND			GRAVEL		

SAMPLE NO	DEPTH (m)	GRAVEL %	SAND %	SILT %	CLAY %	SAMPLE DESCRIPTION
						Dark greenish grey slightly gravelly slightly Sandy SILT

Note:

- Above test was subcontracted to external accredited lab.



R221584/2B

RESULTS

Test Method - BS 1377:1990-PART 2

Particle Size Distribution

Sample ID - Sample 3 - S6

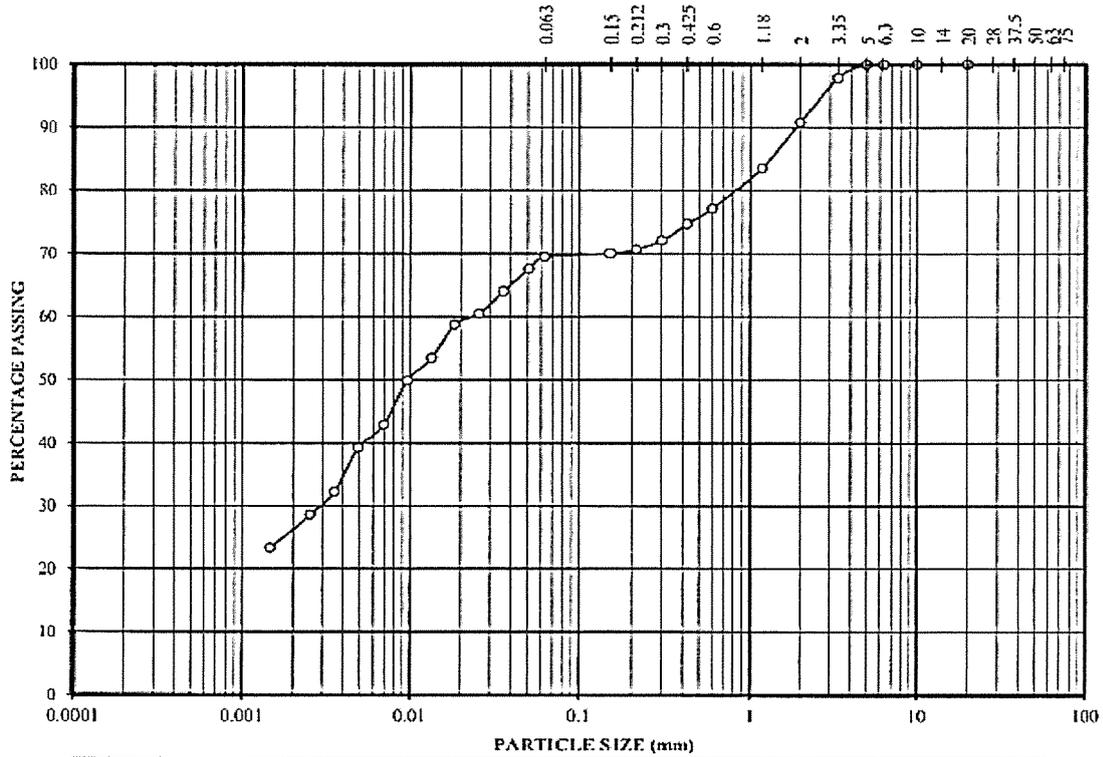

	FINE	MEDIUM	COARSE	FINE	MEDIUM	COARSE	FINE	MEDIUM	COARSE
CLAY	SILT			SAND			GRAVEL		

SAMPLE NO	DEPTH (m)	GRAVEL %	SAND %	SILT %	CLAY %	SAMPLE DESCRIPTION
						Dark greenish grey slightly gravelly slightly Sandy SILT
56	-	9	22	42	27	

Note:

- Above test was subcontracted to external accredited lab.

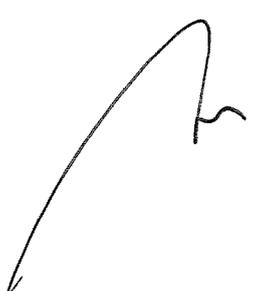

R221584/2B

RESULTS

Test Method - BS 1377:1990-PART 2

Particle Size Distribution

Sample ID - Sample 4 - S8

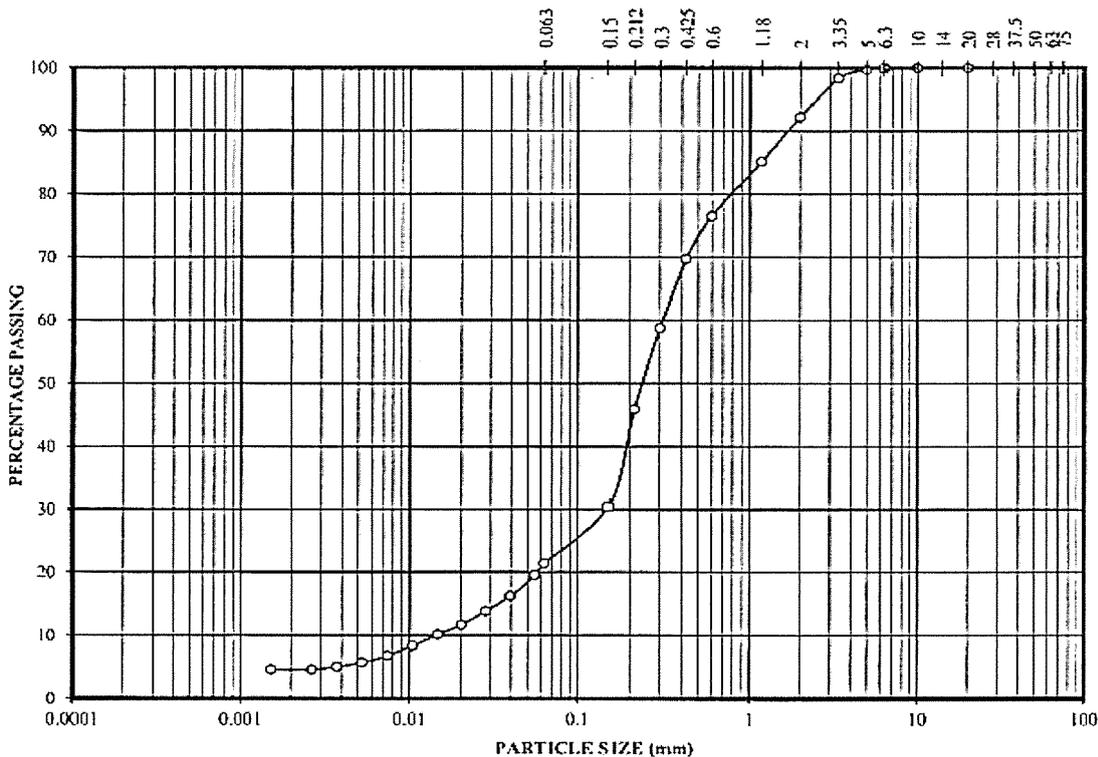

	FINE	MEDIUM	COARSE	FINE	MEDIUM	COARSE	FINE	MEDIUM	COARSE
CLAY	SILT			SAND			GRAVEL		

SAMPLE NO	DEPTH (m)	GRAVEL %	SAND %	SILT %	CLAY %	SAMPLE DESCRIPTION

Note:

- Above test was subcontracted to external accredited lab.

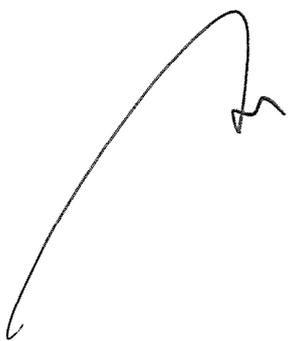

Appendix Q
Sediment Quality Reports
from Northern Pulau Ubin
Project

TEST REPORT

Our Reference No. : **R215255/1**
Project Code / Ref. : Marine Shoreline Project at Pulau Ubin

Date Received : 28/09/2021
Date Commenced : 28/09/2021
Date Reported : 14/10/2021

Customer Ref. No. : -
Customer Name : AECOM Singapore Pte Ltd
Customer Address : 300 Beach Road
#03-00 The Concourse
Singapore 199555

Attention To : Mr. Chan Eu Jin
Sample Description : 6 Soil Samples as per received

RESULTS: Refer to Page 2

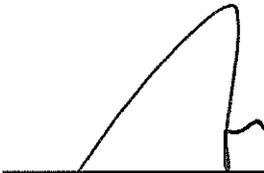

Tan Thuan Piang
Technical Manager

Terms & Conditions:

- 1) This report shall not be reproduced except in full, unless approval in writing has been given by MLS.
- 2) The results in this report only apply to the sample received/analysed.
- 3) MLS agrees to use reasonable diligence in the performance of the service.

Marchwood Laboratory Services Pte Ltd:

Main (Office and Laboratory):

Branch (Site and Laboratory):

Website:

Co. Reg No. : 201422686C

116 Tuas South Ave 2, West Point Bizhub Singapore 637163

216 Tuas South Ave 2, West Point Bizhub Singapore 637213

www.mls.sg

 : +65 6790 0118

 : +65 6262 3736 (Lab)

 : +65 6790 0091

 : +65 6262 3726 / 3776 (Site)

R215255/1

RESULTS:

Test Parameter	Test Method	Unit	N1	N2	N3
			28/09/2021	28/09/2021	28/09/2021
Arsenic as As	USEPA 3051A / APHA 3120B	mg/kg	8.75	8.03	7.84
Cadmium as Cd	USEPA 3051A / APHA 3120B	mg/kg	0.39	0.40	0.43
Chromium as Cr	USEPA 3051A / APHA 3120B	mg/kg	20.9	22.9	20.6
Copper as Cu	USEPA 3051A / APHA 3120B	mg/kg	6.89	7.26	7.26
Nickel as Ni	USEPA 3051A / APHA 3120B	mg/kg	12.9	14.2	13.9
Lead as Pb	USEPA 3051A / APHA 3120B	mg/kg	24.3	24.0	23.7
Zinc as Zn	USEPA 3051A / APHA 3120B	mg/kg	44.0	46.6	44.1
Mercury as Hg	USEPA 3051A / USEPA 245.1 (FIMS) (1994)	mg/kg	0.064	0.053	0.056
Moisture Content	BS 1377-2: 1990	%	41.9	43.5	45.2
Potassium as K (% by dry mass)	USEPA 3051A / APHA 3120B	%	0.34	0.30	0.27
Total Phosphorus as P (% by dry mass)	USEPA 3051A / APHA 3120B	%	0.044	0.021	0.022
Total Nitrogen as N (% by dry mass)	APHA 4500-N _{org} (D)	%	0.070	0.079	0.079
Cation Exchange Capacity*	In-House Method based on USEPA 9080	meq/100g Sodium	11.9	4.13	5.85
Bulk Density	BS 1377:1990 Section 7.2	Mg/m ³	1.57	1.43	1.49
Faecal coliform	FDA-BAM Chapter 4: Jul 2017	MPN/100mL	<3	<3	<3
E.coli	FDA-BAM Chapter 4: Jul 2017	MPN/100mL	<3	<3	<3
Total Petroleum Hydrocarbon	USEPA 8440 (1996)	mg/kg	<10	124	<10

Note:

1. APHA is a standard method for Determination of Water and Waste Water (APHA 23rd Edition, 2017).
2. "<" = less than. The result was less than the detection limit.
3. Results are based on dry weight.
4. *** = The above test were subcontracted to external lab.



R215255/1

RESULTS:

Test Parameter	Test Method	Unit	N4	N5	N6
			28/09/2021	28/09/2021	28/09/2021
Arsenic as As	USEPA 3051A / APHA 3120B	mg/kg	6.10	1.83	1.38
Cadmium as Cd	USEPA 3051A / APHA 3120B	mg/kg	0.53	0.27	0.34
Chromium as Cr	USEPA 3051A / APHA 3120B	mg/kg	29.2	3.54	5.08
Copper as Cu	USEPA 3051A / APHA 3120B	mg/kg	3.81	16.0	1.68
Nickel as Ni	USEPA 3051A / APHA 3120B	mg/kg	4.18	1.83	6.51
Lead as Pb	USEPA 3051A / APHA 3120B	mg/kg	6.99	20.4	77.5
Zinc as Zn	USEPA 3051A / APHA 3120B	mg/kg	9.98	23.7	5.11
Mercury as Hg	USEPA 3051A / USEPA 245.1 (FIMS) (1994)	mg/kg	0.062	0.0098	0.062
Moisture Content	BS 1377-2: 1990	%	26.4	19.4	27.8
Potassium as K (% by dry mass)	USEPA 3051A / APHA 3120B	%	0.035	0.026	0.034
Total Phosphorus as P (% by dry mass)	USEPA 3051A / APHA 3120B	%	0.016	0.0070	0.0049
Total Nitrogen as N (% by dry mass)	APHA 4500-Norg (D)	%	0.024	0.0064	0.0046
Cation Exchange Capacity*	In-House Method based on USEPA 9080	meq/100g Sodium	15.5	5.76	13.5
Bulk Density	BS 1377:1990 Section 7.2	Mg/m ³	1.80	1.93	1.82
Faecal coliform	FDA-BAM Chapter 4: Jul 2017	MPN/100mL	<3	<3	<3
E.coli	FDA-BAM Chapter 4: Jul 2017	MPN/100mL	<3	<3	<3
Total Petroleum Hydrocarbon	USEPA 8440 (1996)	mg/kg	286	<10	127

Note:

1. APHA is a standard method for Determination of Water and Waste Water (APHA 23rd Edition, 2017).
2. "<" = less than. The result was less than the detection limit.
3. Results are based on dry weight.
4. "*" = The above test were subcontracted to external lab.



Appendix R
Survey Report for Acoustic
Doppler Current Profiler
(ADCP) Wave Measurements



YJP SURVEYORS PTE LTD

**REPORT FOR ADCP WAVE
MEASUREMENT DATA
COLLECTED AT
OFFSHORE LOCATION AT
SOUTH PULAU UBIN**

Prepared for:	AECOM Singapore Pte Ltd	By: YJP Surveyors Pte Ltd
----------------------	-------------------------	----------------------------------

Report for ADCP wave measurement data collected at offshore location at South Pulau Ubin



Contents

1	INTRODUCTION.....	3
2	CURRENT AND WAVE HEIGHT MEASUREMENT	4
2.1	DEPLOYMENT OF ADCP	4
Appendix A.	WAVE MEASUREMENT (SIGNIFICANT HEIGHT).....	5
Appendix B.	WAVE MEASUREMENT (CURRENT SPEED)	8
Appendix C.	WAVE MEASUREMENT (CURRENT DIRECTION).....	11
Appendix D.	WAVE & CURRENT DATA	14

Table of Figures

Figure 1-1:	Location of ADCP1	3
Figure 2-1:	Position of ADCP Deployment.....	4
Figure 2-2:	ADCP ready for Deployment	4



YJP SURVEYORS PTE LTD

1 INTRODUCTION

This report depicts the wave measurement data collected from the deployment of the Acoustic Doppler Current Profiler (ADCP) at the offshore location at south of Pulau Ubin for AECOM Singapore Pte Ltd. The purpose of the project (Consultancy Services for Mangrove Restoration at Sungei Durian Ponds Environmental Impact Assessment (EIA)) aims to study and assess the impacts from the ecological mangrove restoration works conducted at said location, which will restore the site elevations to encourage the reestablishment of mangroves within the abandoned prawn ponds.

The proposed location of the ADCP is as shown below, at Latitude 1°24'18.818"N, Longitude 103°58'45.956"E.

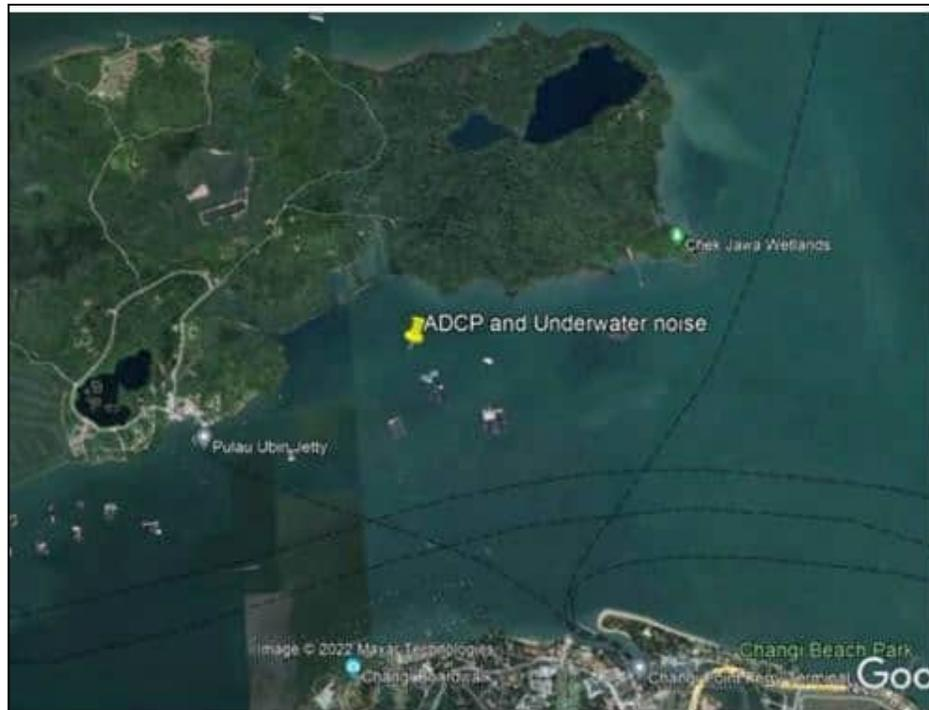

Figure 1-1: Location of ADCP1



2 CURRENT AND WAVE HEIGHT MEASUREMENT

The current speed, current direction and significant wave height were measured over 21 days in September 2022 and 15 days in November 2022. This was carried out at 10min intervals at 10m depth. The deployment details are as shown below.

2.1 DEPLOYMENT OF ADCP

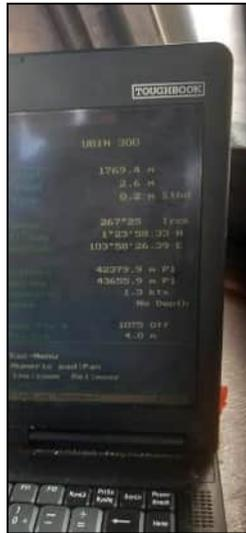

Figure 2-1: Position of ADCP Deployment



Figure 2-2: ADCP ready for Deployment



YJP SURVEYORS PTE LTD

2.2 WATER LEVEL MEASUREMENT

The measurements were referenced to Chart Datum (CD), which is 1.82m below Singapore Height Datum (SHD). The tidal range observed during this period is consistent with the predicted tide published by MPA tidal book.

The range of measurement is between 0.02m (minimum) to 3.39m (maximum).



YJP SURVEYORS PTE LTD

Appendix A. WAVE MEASUREMENT (SIGNIFICANT HEIGHT)



YJP SURVEYORS PTE LTD

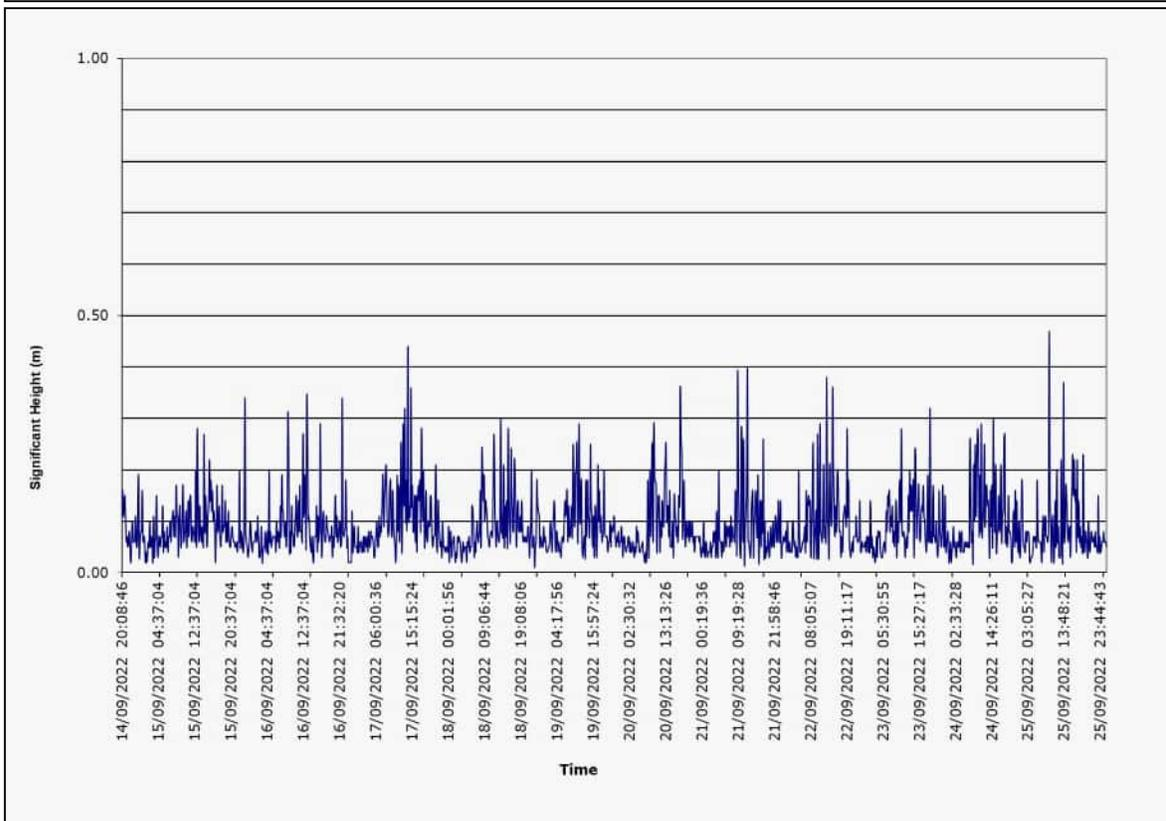
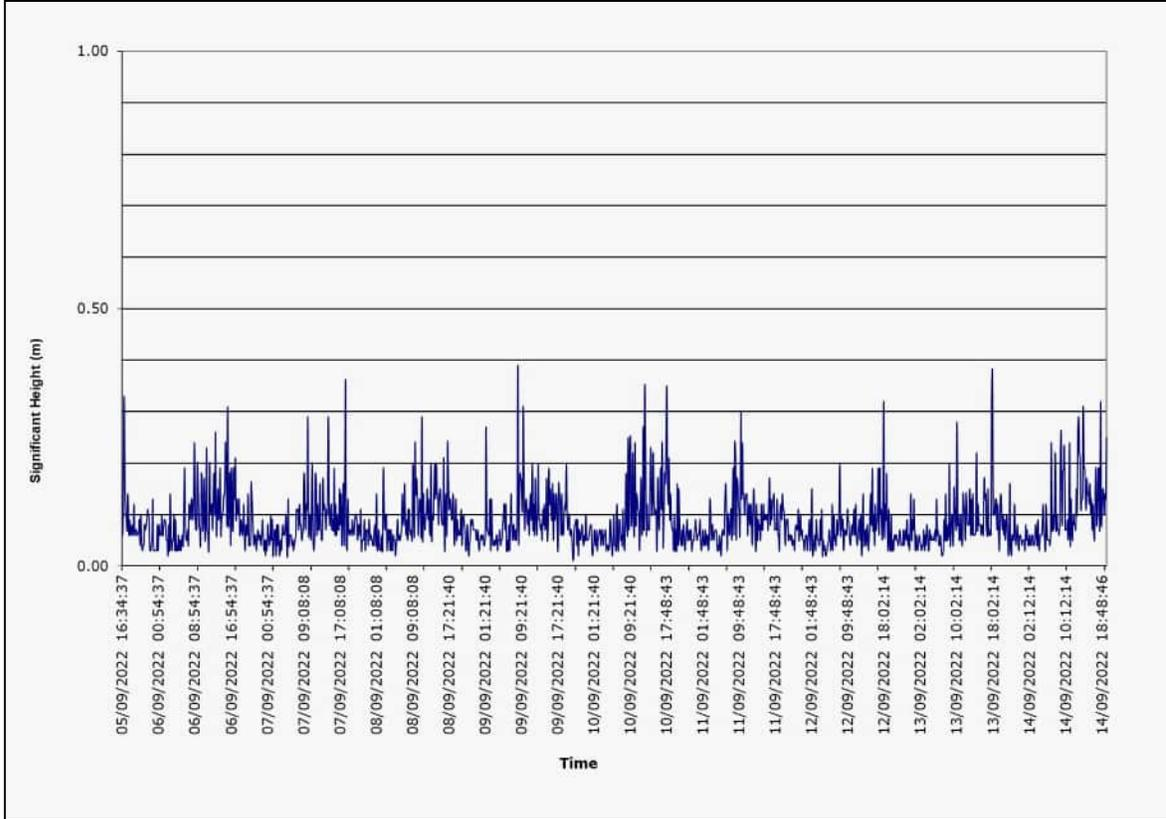



YJP SURVEYORS PTE LTD

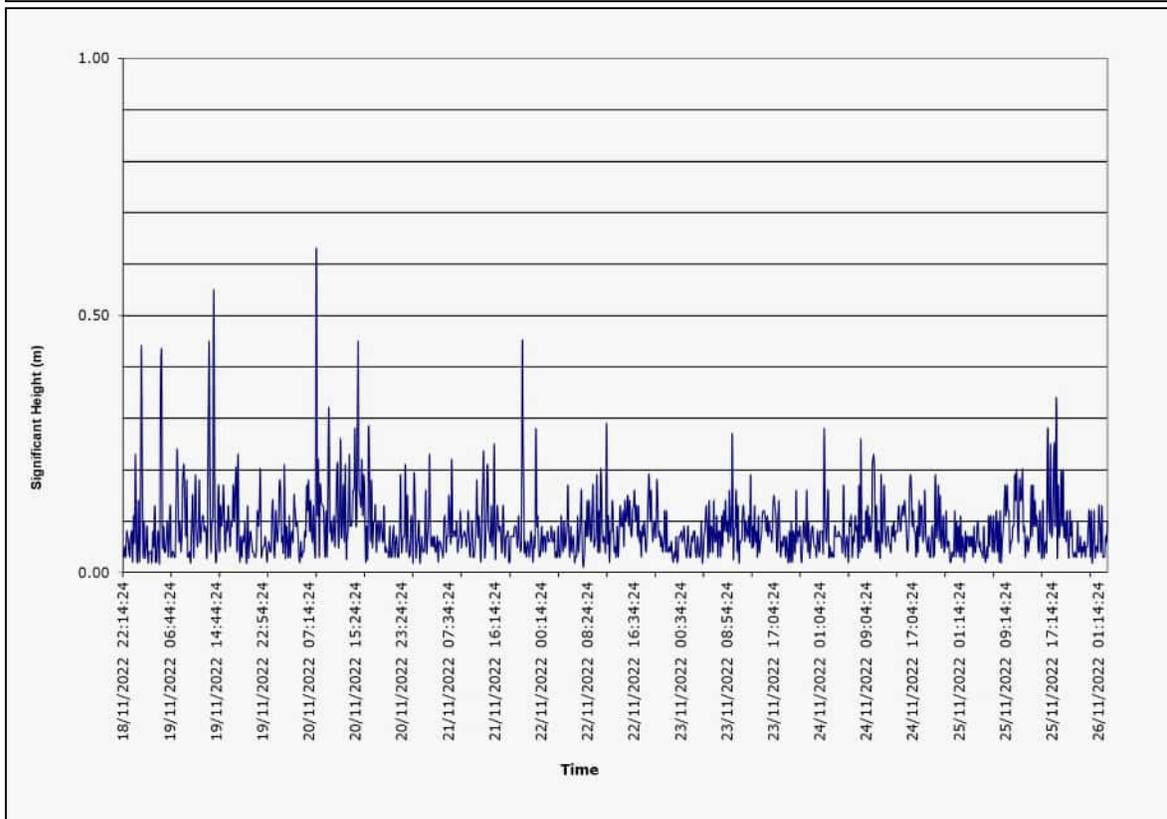
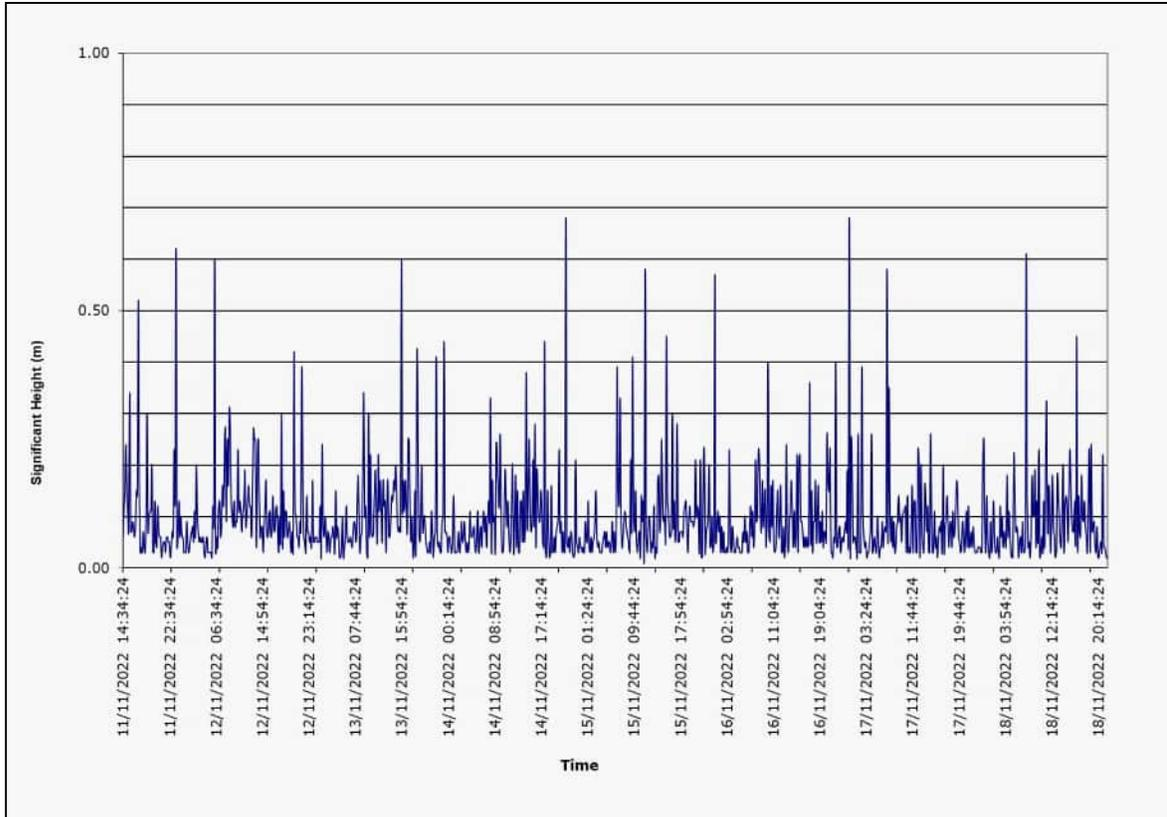



YJP SURVEYORS PTE LTD

Appendix B. WAVE MEASUREMENT (CURRENT SPEED)



YJP SURVEYORS PTE LTD

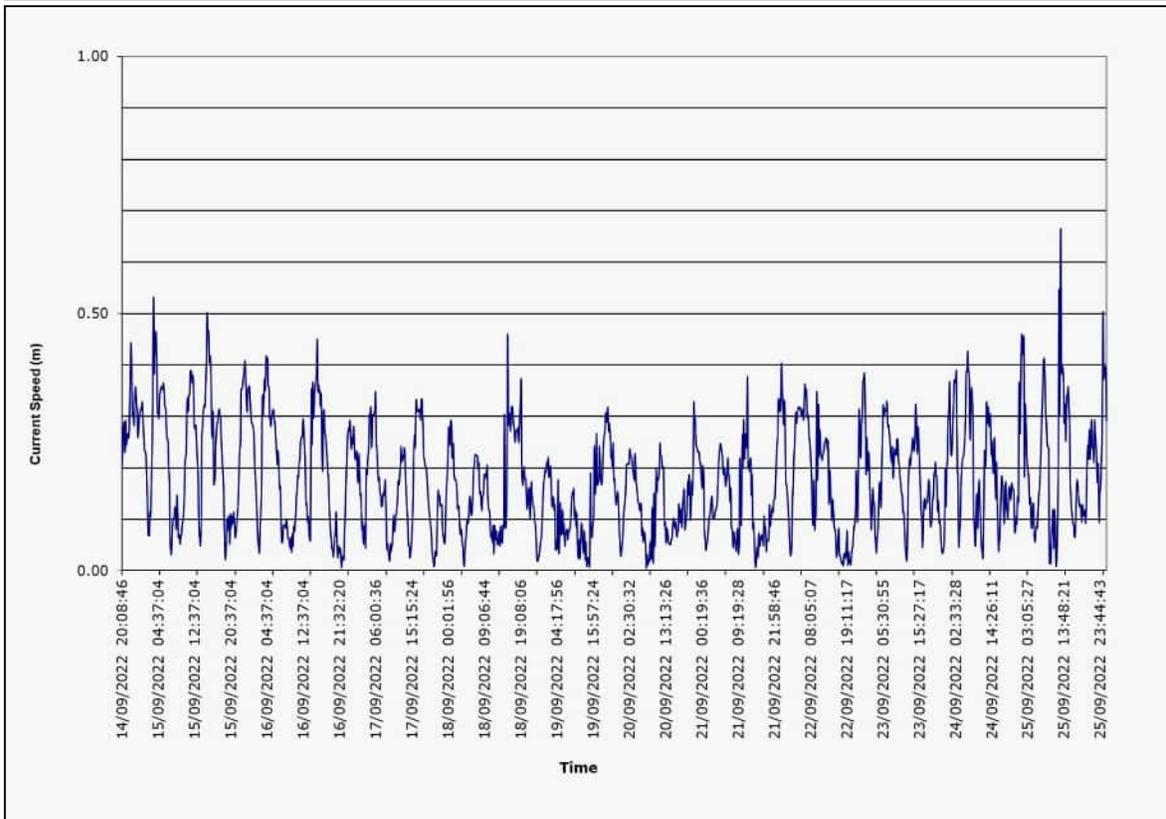
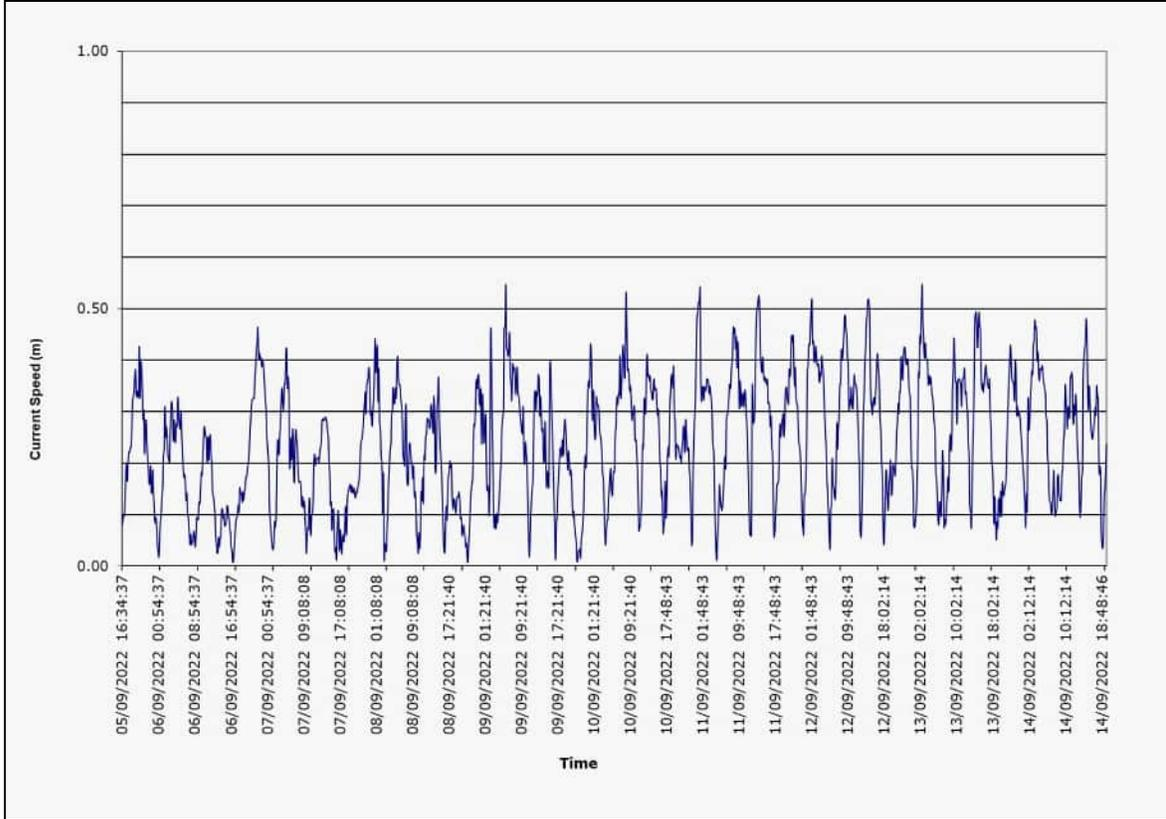



YJP SURVEYORS PTE LTD

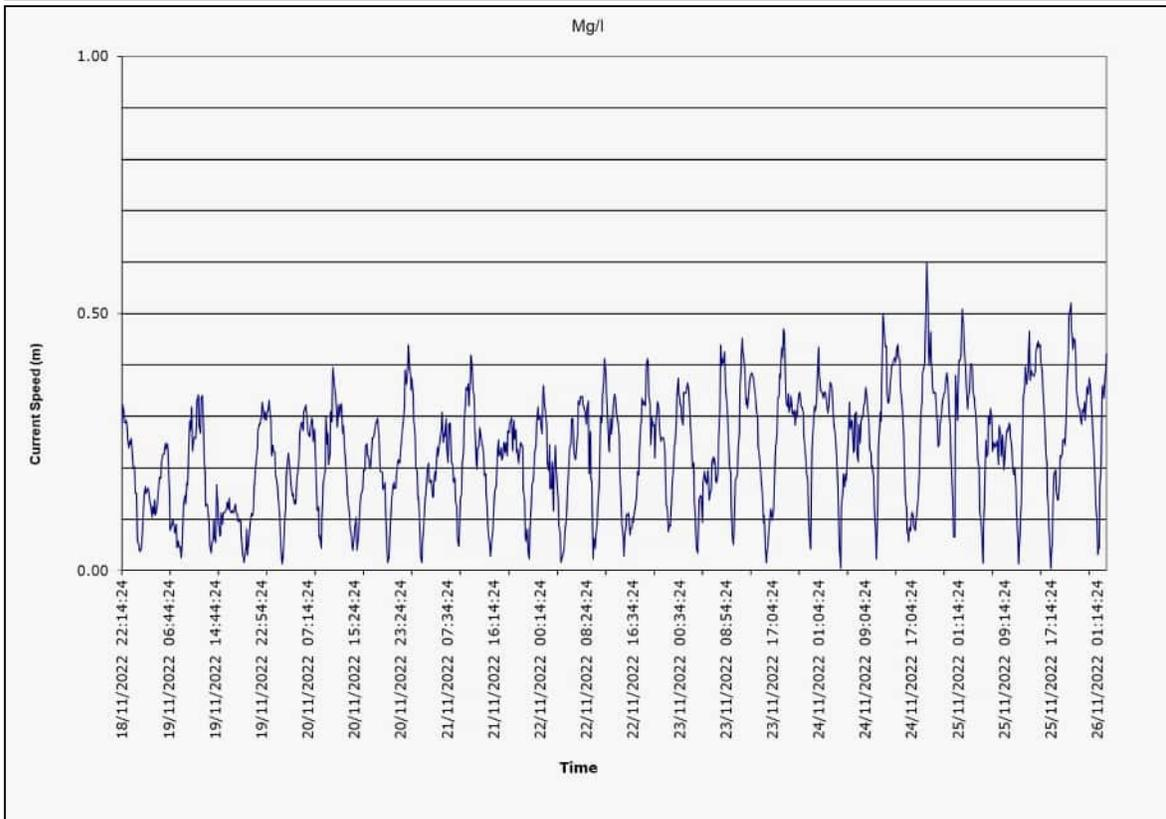
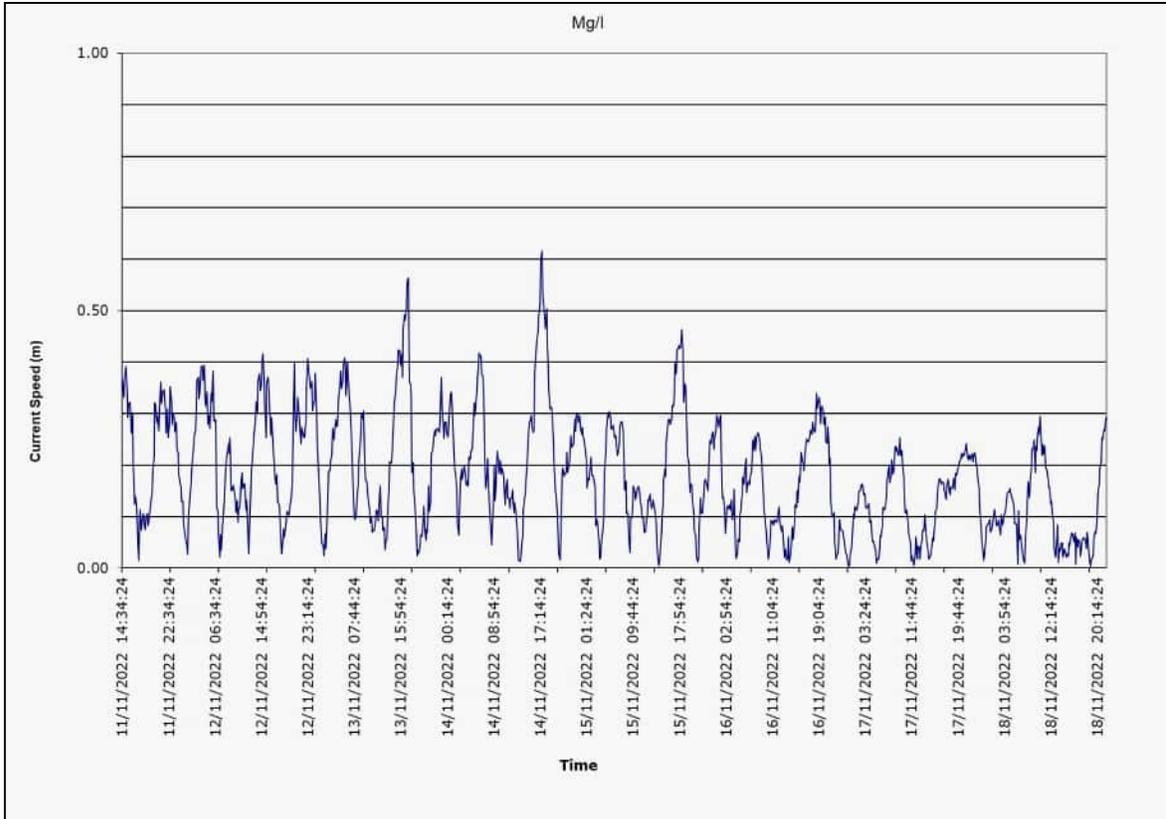



YJP SURVEYORS PTE LTD

Appendix C. WAVE MEASUREMENT (CURRENT DIRECTION)



YJP SURVEYORS PTE LTD

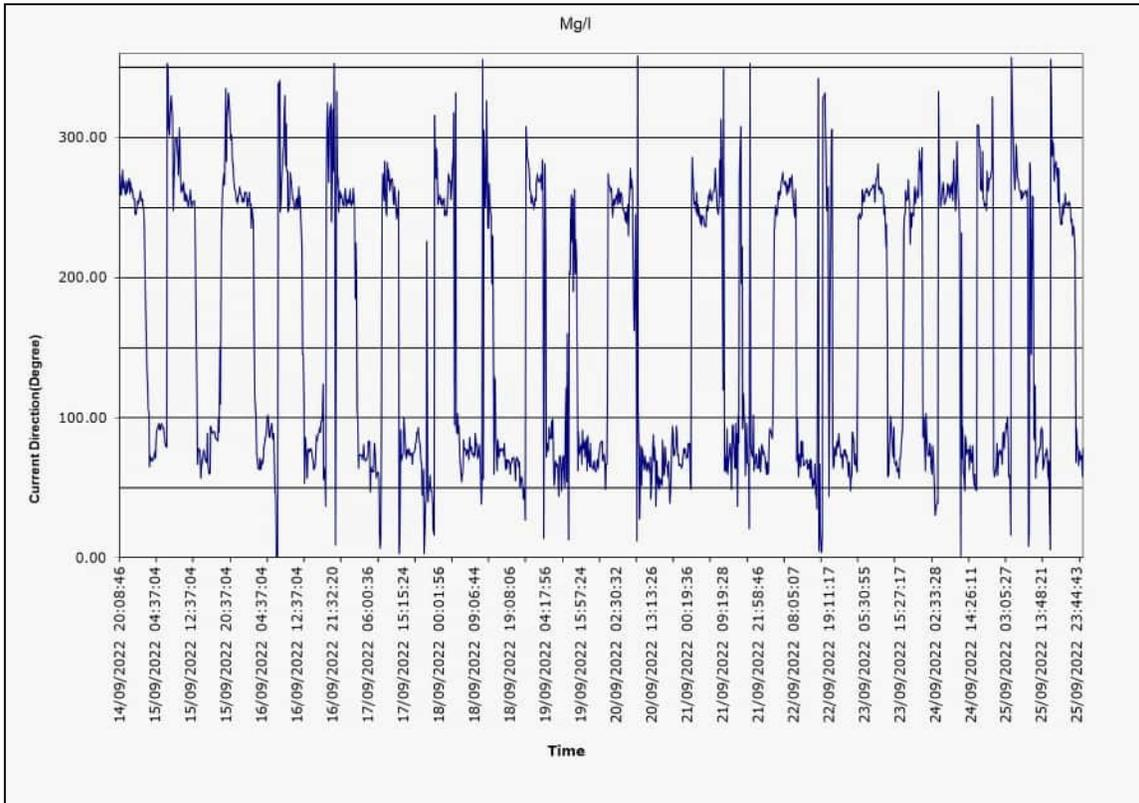
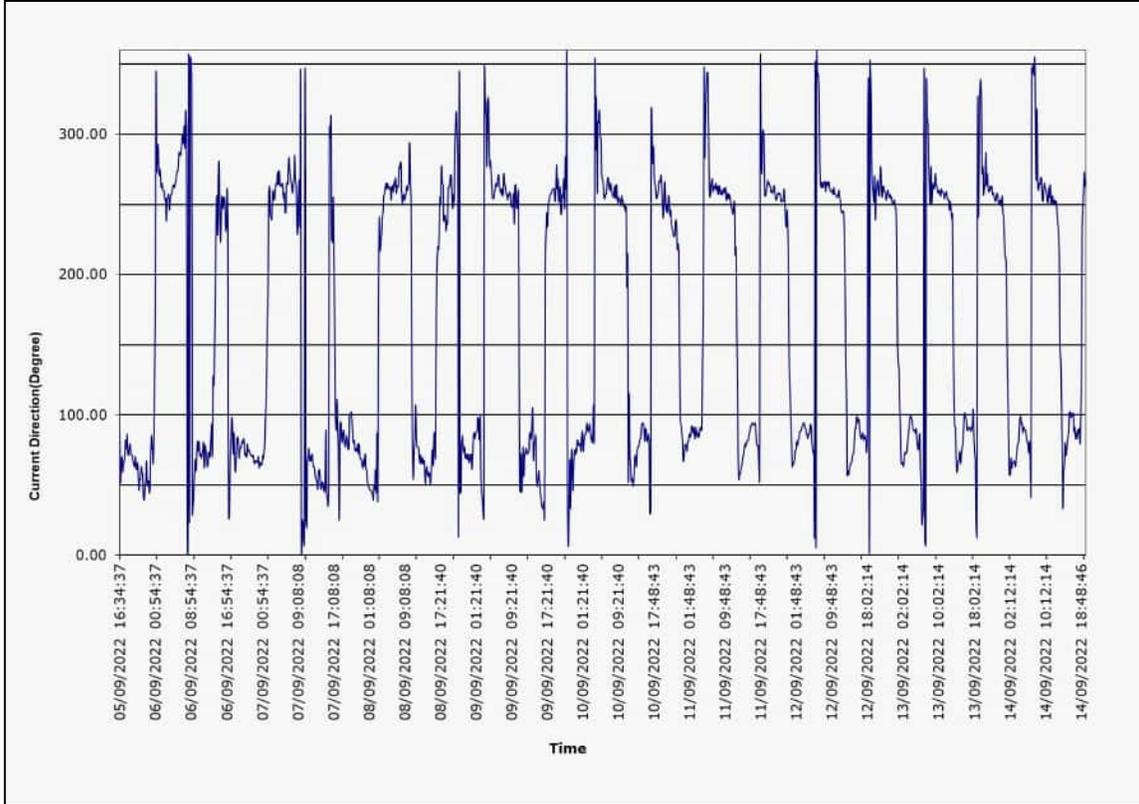



YJP SURVEYORS PTE LTD

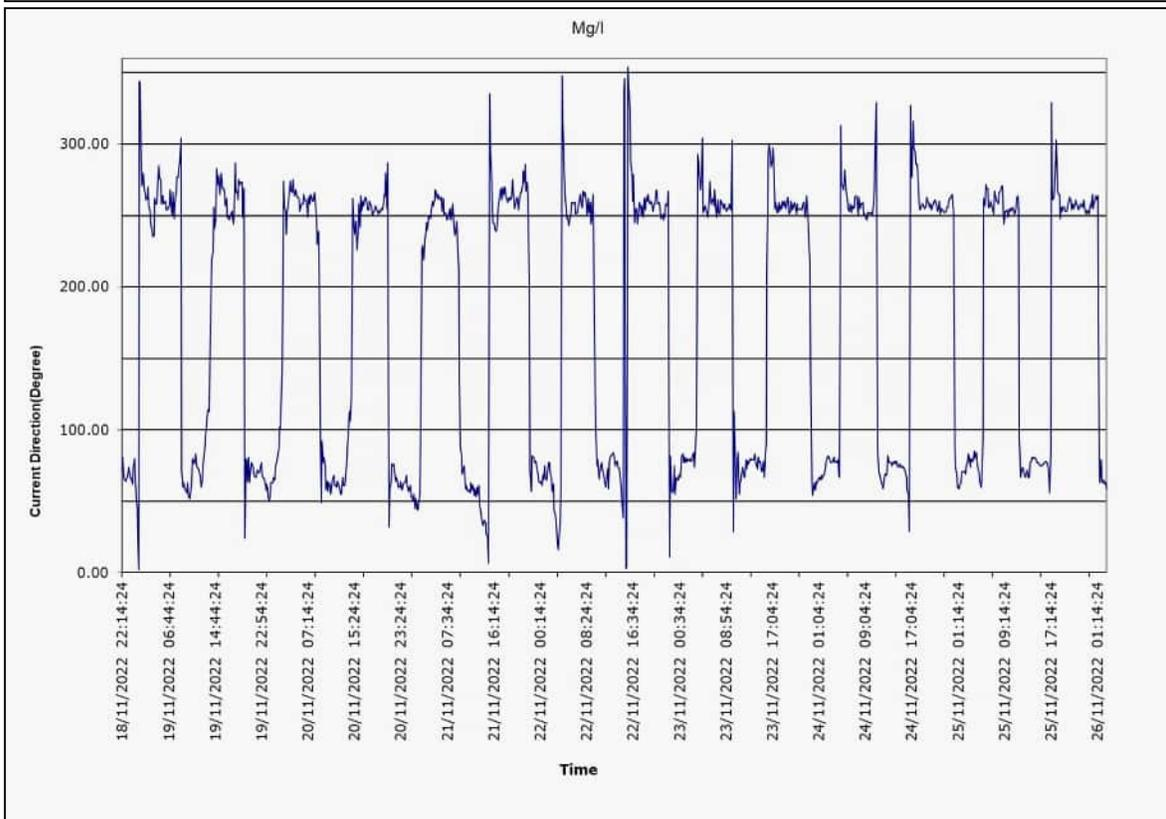
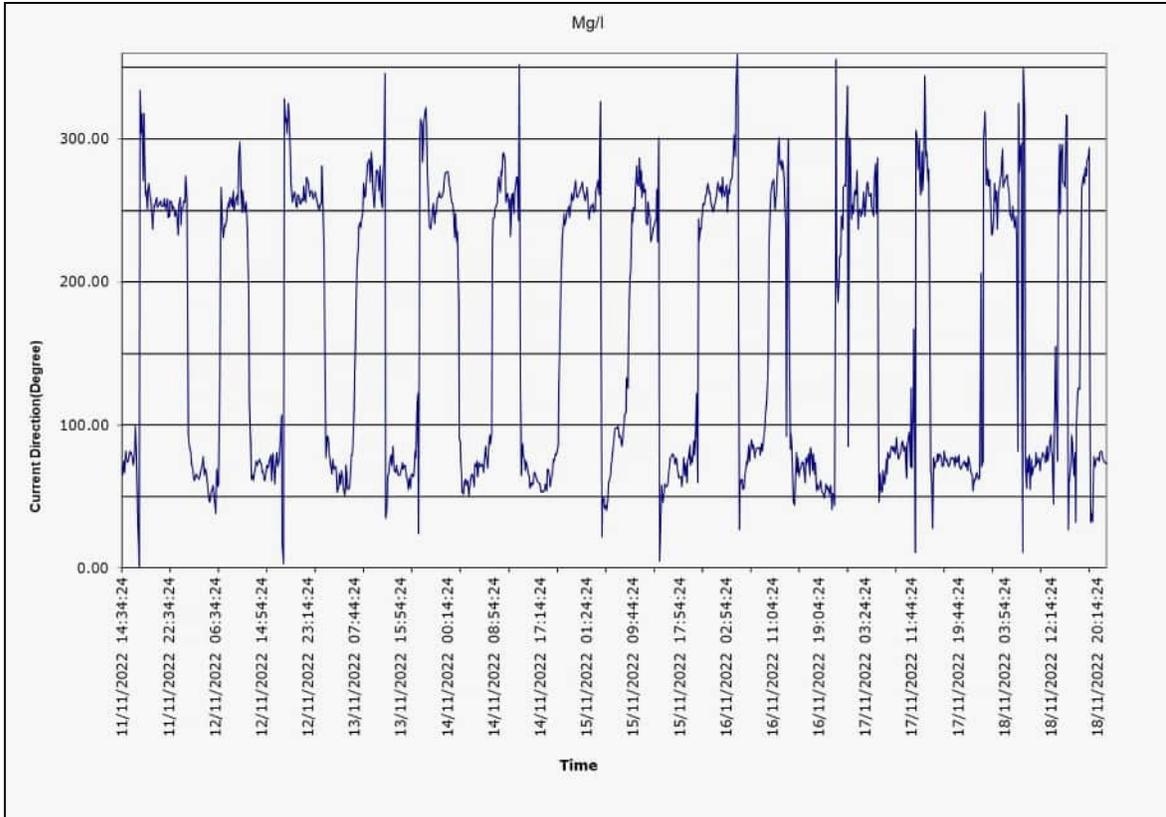



YJP SURVEYORS PTE LTD

Appendix D. WAVE & CURRENT DATA

Name	Date Time	Significant Height(m)	Peak Time(sec)	Peak Direction (degree)	ADCP Depth(m)	Current Speed(m/s)	Current Direction (degree)	water level reference to CD	water level reference to 1.82 SHD
WAVE	05/09/2022 16:34	0.10	3.80	119	10.491	0.077	90.00	2.49	0.67
WAVE	05/09/2022 16:54	0.06	3.20	228	10.516	0.085	52.00	2.52	0.70
WAVE	05/09/2022 17:04	0.14	3.40	115	10.507	0.097	66.00	2.51	0.69
WAVE	05/09/2022 17:14	0.33	2.90	281	10.508	0.097	70.00	2.51	0.69
WAVE	05/09/2022 17:24	0.17	2.90	298	10.513	0.121	59.00	2.51	0.69
WAVE	05/09/2022 17:44	0.11	2.80	92	10.495	0.168	65.00	2.50	0.67
WAVE	05/09/2022 17:54	0.09	2.80	113	10.476	0.198	66.00	2.48	0.66
WAVE	05/09/2022 18:04	0.07	2.80	155	10.442	0.165	72.00	2.44	0.62
WAVE	05/09/2022 18:14	0.14	2.60	243	10.423	0.194	82.00	2.42	0.60
WAVE	05/09/2022 18:24	0.06	9.10	351	10.387	0.222	76.00	2.39	0.57
WAVE	05/09/2022 18:34	0.09	2.70	99	10.355	0.221	86.00	2.36	0.54
WAVE	05/09/2022 18:44	0.07	4.30	107	10.318	0.231	71.00	2.32	0.50
WAVE	05/09/2022 18:54	0.06	16.00	291	10.273	0.23	72.00	2.27	0.45
WAVE	05/09/2022 19:04	0.08	2.70	111	10.219	0.263	77.00	2.22	0.40
WAVE	05/09/2022 19:14	0.06	3.00	95	10.174	0.317	79.00	2.17	0.35
WAVE	05/09/2022 19:24	0.07	2.60	169	10.124	0.329	72.00	2.12	0.30
WAVE	05/09/2022 19:34	0.12	2.70	104	10.048	0.339	71.00	2.05	0.23
WAVE	05/09/2022 19:44	0.06	2.60	99	9.985	0.366	71.00	1.99	0.16
WAVE	05/09/2022 19:54	0.07	3.20	87	9.907	0.381	67.00	1.91	0.09
WAVE	05/09/2022 20:04	0.07	3.40	99	9.837	0.333	65.00	1.84	0.02
WAVE	05/09/2022 20:14	0.06	12.80	169	9.77	0.329	63.00	1.77	-0.05
WAVE	05/09/2022 20:24	0.06	3.60	107	9.704	0.34	70.00	1.70	-0.12
WAVE	05/09/2022 20:34	0.07	5.80	291	9.615	0.328	62.00	1.62	-0.21
WAVE	05/09/2022 20:44	0.09	2.10	95	9.565	0.427	61.00	1.57	-0.26
WAVE	05/09/2022 20:54	0.04	7.10	247	9.48	0.327	66.00	1.48	-0.34
WAVE	05/09/2022 21:04	0.10	2.10	83	9.394	0.396	58.00	1.39	-0.43
WAVE	05/09/2022 21:14	0.05	21.30	59	9.333	0.381	46.00	1.33	-0.49
WAVE	05/09/2022 21:24	0.03	10.70	59	9.243	0.345	54.00	1.24	-0.58
WAVE	05/09/2022 21:34	0.04	12.80	71	9.188	0.285	54.00	1.19	-0.63
WAVE	05/09/2022 21:44	0.04	8.00	135	9.113	0.302	63.00	1.11	-0.71
WAVE	05/09/2022 21:54	0.08	2.60	335	9.056	0.219	59.00	1.06	-0.76
WAVE	05/09/2022 22:04	0.07	2.70	75	9.016	0.263	58.00	1.02	-0.80
WAVE	05/09/2022 22:14	0.08	2.20	267	8.957	0.284	42.00	0.96	-0.86
WAVE	05/09/2022 22:24	0.09	2.90	215	8.884	0.239	39.00	0.88	-0.94
WAVE	05/09/2022 22:34	0.11	2.10	249	8.867	0.211	48.00	0.87	-0.95
WAVE	05/09/2022 22:44	0.10	2.70	91	8.813	0.189	51.00	0.81	-1.01
WAVE	05/09/2022 22:54	0.09	2.30	88	8.792	0.16	67.00	0.79	-1.03
WAVE	05/09/2022 23:04	0.03	12.80	163	8.736	0.16	53.00	0.74	-1.08
WAVE	05/09/2022 23:14	0.03	16.00	263	8.716	0.195	49.00	0.72	-1.10
WAVE	05/09/2022 23:24	0.04	10.70	169	8.679	0.142	53.00	0.68	-1.14
WAVE	05/09/2022 23:34	0.05	9.10	339	8.669	0.143	44.00	0.67	-1.15
WAVE	05/09/2022 23:44	0.13	2.60	76	8.656	0.187	51.00	0.66	-1.16
WAVE	05/09/2022 23:54	0.03	10.70	291	8.647	0.135	74.00	0.65	-1.17
WAVE	06/09/2022 00:04	0.03	12.80	31	8.624	0.106	85.00	0.62	-1.20
WAVE	06/09/2022 00:14	0.03	9.10	75	8.618	0.084	76.00	0.62	-1.20
WAVE	06/09/2022 00:24	0.03	9.10	155	8.613	0.094	65.00	0.61	-1.21
WAVE	06/09/2022 00:34	0.03	16.00	11	8.615	0.074	83.00	0.62	-1.21
WAVE	06/09/2022 00:44	0.08	2.40	127	8.619	0.041	127.00	0.62	-1.20
WAVE	06/09/2022 00:54	0.03	10.70	211	8.632	0.028	183.00	0.63	-1.19
WAVE	06/09/2022 01:04	0.08	2.60	159	8.64	0.018	343.00	0.64	-1.18
WAVE	06/09/2022 01:14	0.06	9.10	169	8.666	0.058	274.00	0.67	-1.15
WAVE	06/09/2022 01:24	0.06	2.30	104	8.694	0.086	284.00	0.69	-1.13
WAVE	06/09/2022 01:34	0.06	2.50	63	8.726	0.102	292.00	0.73	-1.09
WAVE	06/09/2022 01:44	0.10	2.00	93	8.761	0.132	271.00	0.76	-1.06
WAVE	06/09/2022 01:54	0.06	3.00	91	8.796	0.156	275.00	0.80	-1.02
WAVE	06/09/2022 02:04	0.07	2.40	116	8.834	0.214	271.00	0.83	-0.99
WAVE	06/09/2022 02:14	0.09	2.10	131	8.88	0.23	262.00	0.88	-0.94
WAVE	06/09/2022 02:24	0.09	2.20	43	8.916	0.31	265.00	0.92	-0.90
WAVE	06/09/2022 02:34	0.08	2.70	148	8.975	0.251	260.00	0.98	-0.85
WAVE	06/09/2022 02:44	0.05	8.00	339	9.021	0.27	260.00	1.02	-0.80
WAVE	06/09/2022 02:54	0.05	12.80	95	9.078	0.247	259.00	1.08	-0.74
WAVE	06/09/2022 03:04	0.02	16.00	91	9.13	0.213	253.00	1.13	-0.69
WAVE	06/09/2022 03:14	0.08	10.70	169	9.185	0.208	254.00	1.19	-0.64
WAVE	06/09/2022 03:24	0.03	12.80	91	9.231	0.201	238.00	1.23	-0.59

Name	Date Time	Significant Height(m)	Peak Time(sec)	Peak Direction (degree)	ADCP Depth(m)	Current Speed(m/s)	Current Direction (degree)	water level reference to CD	water level reference to 1.82 SHD
WAVE	06/09/2022 03:34	0.14	2.30	54	9.29	0.256	254.00	1.29	-0.53
WAVE	06/09/2022 03:44	0.06	21.30	167	9.344	0.308	255.00	1.34	-0.48
WAVE	06/09/2022 03:54	0.03	12.80	59	9.389	0.32	257.00	1.39	-0.43
WAVE	06/09/2022 04:04	0.05	7.10	291	9.446	0.302	246.00	1.45	-0.37
WAVE	06/09/2022 04:14	0.05	10.70	227	9.488	0.243	253.00	1.49	-0.33
WAVE	06/09/2022 04:24	0.10	3.80	242	9.532	0.284	257.00	1.53	-0.29
WAVE	06/09/2022 04:34	0.03	10.70	169	9.587	0.247	257.00	1.59	-0.23
WAVE	06/09/2022 04:44	0.09	2.20	223	9.631	0.24	261.00	1.63	-0.19
WAVE	06/09/2022 04:54	0.03	16.00	169	9.687	0.277	263.00	1.69	-0.13
WAVE	06/09/2022 05:04	0.04	6.40	351	9.747	0.271	264.00	1.75	-0.07
WAVE	06/09/2022 05:14	0.03	21.30	259	9.798	0.328	262.00	1.80	-0.02
WAVE	06/09/2022 05:24	0.06	3.40	123	9.844	0.297	265.00	1.84	0.02
WAVE	06/09/2022 05:34	0.03	9.10	327	9.892	0.274	267.00	1.89	0.07
WAVE	06/09/2022 05:44	0.05	10.70	47	9.943	0.268	273.00	1.94	0.12
WAVE	06/09/2022 05:54	0.03	16.00	223	9.998	0.302	273.00	2.00	0.18
WAVE	06/09/2022 06:04	0.05	9.10	231	10.054	0.257	279.00	2.05	0.23
WAVE	06/09/2022 06:14	0.06	16.00	169	10.103	0.224	287.00	2.10	0.28
WAVE	06/09/2022 06:24	0.04	21.30	287	10.153	0.194	286.00	2.15	0.33
WAVE	06/09/2022 06:34	0.12	2.40	186	10.185	0.172	285.00	2.19	0.37
WAVE	06/09/2022 06:44	0.19	3.60	214	10.211	0.178	289.00	2.21	0.39
WAVE	06/09/2022 06:54	0.07	4.00	107	10.238	0.16	297.00	2.24	0.42
WAVE	06/09/2022 07:04	0.05	10.70	255	10.266	0.127	300.00	2.27	0.45
WAVE	06/09/2022 07:14	0.05	12.80	107	10.287	0.142	293.00	2.29	0.47
WAVE	06/09/2022 07:24	0.07	2.80	351	10.311	0.101	306.00	2.31	0.49
WAVE	06/09/2022 07:34	0.04	9.10	169	10.338	0.094	290.00	2.34	0.52
WAVE	06/09/2022 07:44	0.12	3.00	251	10.359	0.071	317.00	2.36	0.54
WAVE	06/09/2022 07:54	0.11	3.00	143	10.37	0.042	306.00	2.37	0.55
WAVE	06/09/2022 08:04	0.09	2.60	104	10.376	0.062	61.00	2.38	0.56
WAVE	06/09/2022 08:14	0.13	2.90	269	10.378	0.042	1.00	2.38	0.56
WAVE	06/09/2022 08:24	0.12	2.50	309	10.397	0.046	357.00	2.40	0.58
WAVE	06/09/2022 08:34	0.09	2.70	319	10.41	0.049	23.00	2.41	0.59
WAVE	06/09/2022 08:44	0.14	2.50	111	10.421	0.068	355.00	2.42	0.60
WAVE	06/09/2022 08:54	0.24	2.30	17	10.425	0.06	353.00	2.43	0.61
WAVE	06/09/2022 09:04	0.11	3.80	95	10.437	0.037	337.00	2.44	0.62
WAVE	06/09/2022 09:14	0.07	12.80	169	10.43	0.055	29.00	2.43	0.61
WAVE	06/09/2022 09:24	0.07	2.90	103	10.436	0.094	36.00	2.44	0.62
WAVE	06/09/2022 09:34	0.20	2.90	111	10.434	0.091	46.00	2.43	0.61
WAVE	06/09/2022 09:44	0.14	2.70	101	10.424	0.091	60.00	2.42	0.60
WAVE	06/09/2022 09:54	0.08	3.40	115	10.402	0.124	68.00	2.40	0.58
WAVE	06/09/2022 10:04	0.07	2.80	105	10.381	0.121	60.00	2.38	0.56
WAVE	06/09/2022 10:14	0.04	9.10	169	10.348	0.147	74.00	2.35	0.53
WAVE	06/09/2022 10:24	0.18	2.70	128	10.324	0.182	81.00	2.32	0.50
WAVE	06/09/2022 10:34	0.17	3.20	96	10.277	0.176	74.00	2.28	0.46
WAVE	06/09/2022 10:44	0.07	2.90	119	10.245	0.207	81.00	2.25	0.42
WAVE	06/09/2022 10:54	0.09	2.60	311	10.209	0.243	71.00	2.21	0.39
WAVE	06/09/2022 11:04	0.17	2.80	294	10.162	0.271	72.00	2.16	0.34
WAVE	06/09/2022 11:14	0.05	10.70	295	10.126	0.261	69.00	2.13	0.31
WAVE	06/09/2022 11:24	0.07	2.80	95	10.092	0.251	72.00	2.09	0.27
WAVE	06/09/2022 11:34	0.23	1.90	87	10.047	0.249	75.00	2.05	0.23
WAVE	06/09/2022 11:44	0.07	3.00	115	10.007	0.202	80.00	2.01	0.19
WAVE	06/09/2022 11:54	0.06	3.20	119	9.972	0.251	62.00	1.97	0.15
WAVE	06/09/2022 12:04	0.03	21.30	99	9.946	0.206	78.00	1.95	0.13
WAVE	06/09/2022 12:14	0.20	3.20	90	9.922	0.246	75.00	1.92	0.10
WAVE	06/09/2022 12:24	0.11	2.70	315	9.91	0.255	72.00	1.91	0.09
WAVE	06/09/2022 12:34	0.10	2.60	87	9.89	0.214	63.00	1.89	0.07
WAVE	06/09/2022 12:44	0.12	2.70	94	9.871	0.2	64.00	1.87	0.05
WAVE	06/09/2022 12:54	0.07	9.10	169	9.861	0.144	73.00	1.86	0.04
WAVE	06/09/2022 13:04	0.14	3.00	108	9.853	0.137	71.00	1.85	0.03
WAVE	06/09/2022 13:14	0.18	2.60	96	9.85	0.124	70.00	1.85	0.03
WAVE	06/09/2022 13:24	0.10	2.60	299	9.867	0.107	84.00	1.87	0.05
WAVE	06/09/2022 13:34	0.26	4.30	103	9.87	0.063	93.00	1.87	0.05
WAVE	06/09/2022 13:44	0.06	3.80	171	9.89	0.044	71.00	1.89	0.07
WAVE	06/09/2022 13:54	0.09	2.60	257	9.898	0.025	127.00	1.90	0.08
WAVE	06/09/2022 14:04	0.15	3.80	103	9.915	0.027	121.00	1.92	0.09

Name	Date Time	Significant Height(m)	Peak Time(sec)	Peak Direction (degree)	ADCP Depth(m)	Current Speed(m/s)	Current Direction (degree)	water level reference to CD	water level reference to 1.82 SHD
WAVE	06/09/2022 14:14	0.09	2.70	189	9.923	0.056	149.00	1.92	0.10
WAVE	06/09/2022 14:24	0.11	3.60	143	9.946	0.038	188.00	1.95	0.13
WAVE	06/09/2022 14:34	0.19	2.60	293	9.967	0.055	238.00	1.97	0.15
WAVE	06/09/2022 14:44	0.06	8.00	169	9.986	0.059	256.00	1.99	0.17
WAVE	06/09/2022 14:54	0.09	2.90	99	10.015	0.109	228.00	2.02	0.20
WAVE	06/09/2022 15:04	0.10	2.60	326	10.043	0.112	265.00	2.04	0.22
WAVE	06/09/2022 15:14	0.11	2.30	31	10.069	0.093	280.00	2.07	0.25
WAVE	06/09/2022 15:24	0.14	2.90	112	10.1	0.097	240.00	2.10	0.28
WAVE	06/09/2022 15:34	0.14	2.80	351	10.123	0.078	223.00	2.12	0.30
WAVE	06/09/2022 15:44	0.24	4.00	103	10.159	0.08	247.00	2.16	0.34
WAVE	06/09/2022 15:54	0.19	2.20	305	10.191	0.083	256.00	2.19	0.37
WAVE	06/09/2022 16:04	0.08	2.70	124	10.225	0.117	247.00	2.23	0.41
WAVE	06/09/2022 16:14	0.31	3.00	125	10.252	0.116	253.00	2.25	0.43
WAVE	06/09/2022 16:24	0.08	9.10	331	10.278	0.096	255.00	2.28	0.46
WAVE	06/09/2022 16:34	0.12	2.80	283	10.304	0.092	247.00	2.30	0.48
WAVE	06/09/2022 16:44	0.18	2.90	115	10.334	0.072	231.00	2.33	0.51
WAVE	06/09/2022 16:54	0.04	9.10	169	10.357	0.06	235.00	2.36	0.54
WAVE	06/09/2022 17:04	0.19	4.00	128	10.382	0.034	261.00	2.38	0.56
WAVE	06/09/2022 17:14	0.11	2.70	147	10.417	0.026	210.00	2.42	0.60
WAVE	06/09/2022 17:24	0.07	2.70	99	10.437	0.007	26.00	2.44	0.62
WAVE	06/09/2022 17:34	0.19	2.80	119	10.456	0.019	31.00	2.46	0.64
WAVE	06/09/2022 17:44	0.13	2.20	95	10.472	0.044	71.00	2.47	0.65
WAVE	06/09/2022 17:54	0.21	1.90	92	10.484	0.069	80.00	2.48	0.66
WAVE	06/09/2022 18:04	0.09	2.70	92	10.469	0.091	98.00	2.47	0.65
WAVE	06/09/2022 18:14	0.13	2.30	103	10.476	0.094	92.00	2.48	0.66
WAVE	06/09/2022 18:24	0.10	2.50	338	10.474	0.103	72.00	2.47	0.65
WAVE	06/09/2022 18:34	0.10	2.40	355	10.471	0.119	87.00	2.47	0.65
WAVE	06/09/2022 18:44	0.13	2.30	327	10.463	0.105	69.00	2.46	0.64
WAVE	06/09/2022 18:54	0.06	3.40	169	10.446	0.152	59.00	2.45	0.63
WAVE	06/09/2022 19:04	0.07	8.00	159	10.426	0.142	67.00	2.43	0.61
WAVE	06/09/2022 19:14	0.09	2.40	347	10.4	0.142	82.00	2.40	0.58
WAVE	06/09/2022 19:24	0.06	21.30	147	10.384	0.124	84.00	2.38	0.56
WAVE	06/09/2022 19:34	0.07	2.60	111	10.363	0.144	81.00	2.36	0.54
WAVE	06/09/2022 19:44	0.12	2.10	93	10.337	0.128	69.00	2.34	0.52
WAVE	06/09/2022 19:54	0.06	10.70	307	10.321	0.144	75.00	2.32	0.50
WAVE	06/09/2022 20:04	0.03	16.00	19	10.287	0.151	76.00	2.29	0.47
WAVE	06/09/2022 20:14	0.08	2.80	101	10.261	0.173	78.00	2.26	0.44
WAVE	06/09/2022 20:24	0.06	3.00	171	10.218	0.173	81.00	2.22	0.40
WAVE	06/09/2022 20:34	0.06	2.80	81	10.194	0.188	80.00	2.19	0.37
WAVE	06/09/2022 20:44	0.14	2.10	339	10.149	0.198	83.00	2.15	0.33
WAVE	06/09/2022 20:54	0.04	3.60	263	10.106	0.21	79.00	2.11	0.29
WAVE	06/09/2022 21:04	0.04	21.30	167	10.063	0.244	71.00	2.06	0.24
WAVE	06/09/2022 21:14	0.04	21.30	295	10.018	0.273	73.00	2.02	0.20
WAVE	06/09/2022 21:24	0.16	2.90	130	9.961	0.299	70.00	1.96	0.14
WAVE	06/09/2022 21:34	0.13	2.70	261	9.912	0.323	79.00	1.91	0.09
WAVE	06/09/2022 21:44	0.10	2.50	84	9.855	0.325	74.00	1.86	0.04
WAVE	06/09/2022 21:54	0.05	9.10	307	9.798	0.325	75.00	1.80	-0.02
WAVE	06/09/2022 22:04	0.04	3.80	169	9.738	0.326	74.00	1.74	-0.08
WAVE	06/09/2022 22:14	0.06	3.80	91	9.672	0.367	72.00	1.67	-0.15
WAVE	06/09/2022 22:24	0.06	4.30	127	9.605	0.386	71.00	1.61	-0.22
WAVE	06/09/2022 22:34	0.03	9.10	279	9.537	0.421	71.00	1.54	-0.28
WAVE	06/09/2022 22:44	0.05	16.00	63	9.471	0.434	70.00	1.47	-0.35
WAVE	06/09/2022 22:54	0.07	2.50	91	9.405	0.464	71.00	1.41	-0.42
WAVE	06/09/2022 23:04	0.06	9.10	91	9.342	0.403	67.00	1.34	-0.48
WAVE	06/09/2022 23:14	0.05	10.70	171	9.268	0.414	65.00	1.27	-0.55
WAVE	06/09/2022 23:24	0.06	9.10	103	9.2	0.401	67.00	1.20	-0.62
WAVE	06/09/2022 23:34	0.04	12.80	169	9.131	0.405	67.00	1.13	-0.69
WAVE	06/09/2022 23:44	0.06	2.80	127	9.06	0.387	66.00	1.06	-0.76
WAVE	06/09/2022 23:54	0.09	3.20	75	8.997	0.401	67.00	1.00	-0.82
WAVE	07/09/2022 00:04	0.06	2.90	43	8.939	0.394	70.00	0.94	-0.88
WAVE	07/09/2022 00:14	0.03	9.10	319	8.882	0.371	62.00	0.88	-0.94
WAVE	07/09/2022 00:24	0.05	21.30	303	8.838	0.348	66.00	0.84	-0.98
WAVE	07/09/2022 00:34	0.02	9.10	111	8.805	0.318	65.00	0.81	-1.02
WAVE	07/09/2022 00:44	0.05	8.00	331	8.785	0.302	64.00	0.79	-1.04

Name	Date Time	Significant Height(m)	Peak Time(sec)	Peak Direction (degree)	ADCP Depth(m)	Current Speed(m/s)	Current Direction (degree)	water level reference to CD	water level reference to 1.82 SHD
WAVE	07/09/2022 00:54	0.03	16.00	103	8.765	0.249	66.00	0.77	-1.06
WAVE	07/09/2022 01:04	0.08	2.40	85	8.681	0.224	71.00	0.68	-1.14
WAVE	07/09/2022 01:14	0.06	2.70	83	8.662	0.209	69.00	0.66	-1.16
WAVE	07/09/2022 01:24	0.04	9.10	23	8.648	0.132	76.00	0.65	-1.17
WAVE	07/09/2022 01:34	0.05	16.00	107	8.628	0.092	86.00	0.63	-1.19
WAVE	07/09/2022 01:44	0.10	2.50	171	8.615	0.074	105.00	0.62	-1.21
WAVE	07/09/2022 01:54	0.05	16.00	131	8.614	0.052	126.00	0.61	-1.21
WAVE	07/09/2022 02:04	0.09	2.50	99	8.607	0.037	163.00	0.61	-1.21
WAVE	07/09/2022 02:14	0.02	16.00	199	8.62	0.032	185.00	0.62	-1.20
WAVE	07/09/2022 02:24	0.04	9.10	169	8.621	0.042	256.00	0.62	-1.20
WAVE	07/09/2022 02:34	0.07	2.40	343	8.642	0.086	263.00	0.64	-1.18
WAVE	07/09/2022 02:44	0.07	3.20	155	8.657	0.075	243.00	0.66	-1.16
WAVE	07/09/2022 02:54	0.02	10.70	169	8.684	0.093	241.00	0.68	-1.14
WAVE	07/09/2022 03:04	0.08	6.40	147	8.714	0.167	239.00	0.71	-1.11
WAVE	07/09/2022 03:14	0.04	21.30	135	8.743	0.244	255.00	0.74	-1.08
WAVE	07/09/2022 03:24	0.08	16.00	351	8.775	0.222	260.00	0.78	-1.05
WAVE	07/09/2022 03:48	0.03	12.80	331	8.885	0.217	253.00	0.89	-0.94
WAVE	07/09/2022 03:58	0.02	9.10	151	8.94	0.256	255.00	0.94	-0.88
WAVE	07/09/2022 04:08	0.05	12.80	83	9.004	0.283	262.00	1.00	-0.82
WAVE	07/09/2022 04:18	0.03	12.80	79	9.058	0.327	265.00	1.06	-0.76
WAVE	07/09/2022 04:28	0.06	3.20	243	9.124	0.346	264.00	1.12	-0.70
WAVE	07/09/2022 04:38	0.08	2.60	225	9.201	0.314	273.00	1.20	-0.62
WAVE	07/09/2022 04:48	0.06	9.10	159	9.282	0.305	264.00	1.28	-0.54
WAVE	07/09/2022 04:58	0.06	9.10	107	9.343	0.355	274.00	1.34	-0.48
WAVE	07/09/2022 05:08	0.07	2.30	239	9.414	0.354	264.00	1.41	-0.41
WAVE	07/09/2022 05:18	0.10	2.50	158	9.49	0.414	263.00	1.49	-0.33
WAVE	07/09/2022 05:28	0.05	8.00	259	9.562	0.423	263.00	1.56	-0.26
WAVE	07/09/2022 05:38	0.02	9.10	231	9.634	0.346	265.00	1.63	-0.19
WAVE	07/09/2022 05:48	0.13	2.90	242	9.693	0.368	262.00	1.69	-0.13
WAVE	07/09/2022 05:58	0.04	3.80	219	9.764	0.337	254.00	1.76	-0.06
WAVE	07/09/2022 06:08	0.06	3.60	167	9.83	0.191	258.00	1.83	0.01
WAVE	07/09/2022 06:18	0.06	9.10	7	9.894	0.206	244.00	1.89	0.07
WAVE	07/09/2022 06:28	0.06	10.70	307	9.954	0.249	244.00	1.95	0.13
WAVE	07/09/2022 06:38	0.04	21.30	99	10.02	0.208	265.00	2.02	0.20
WAVE	07/09/2022 06:48	0.05	4.00	99	10.079	0.267	264.00	2.08	0.26
WAVE	07/09/2022 06:58	0.03	9.10	11	10.133	0.202	266.00	2.13	0.31
WAVE	07/09/2022 07:08	0.04	9.10	169	10.178	0.162	283.00	2.18	0.36
WAVE	07/09/2022 07:18	0.05	10.70	75	10.224	0.218	276.00	2.22	0.40
WAVE	07/09/2022 07:28	0.06	3.00	339	10.266	0.265	270.00	2.27	0.45
WAVE	07/09/2022 07:38	0.11	2.90	104	10.31	0.246	266.00	2.31	0.49
WAVE	07/09/2022 07:48	0.11	2.90	123	10.357	0.235	263.00	2.36	0.54
WAVE	07/09/2022 07:58	0.11	2.30	31	10.41	0.191	258.00	2.41	0.59
WAVE	07/09/2022 08:08	0.07	3.00	115	10.45	0.164	264.00	2.45	0.63
WAVE	07/09/2022 08:18	0.12	2.10	81	10.497	0.165	269.00	2.50	0.68
WAVE	07/09/2022 08:28	0.08	2.90	111	10.519	0.165	285.00	2.52	0.70
WAVE	07/09/2022 08:38	0.08	2.30	107	10.555	0.151	266.00	2.56	0.74
WAVE	07/09/2022 08:48	0.05	10.70	139	10.588	0.117	264.00	2.59	0.77
WAVE	07/09/2022 08:58	0.06	3.00	247	10.611	0.135	240.00	2.61	0.79
WAVE	07/09/2022 09:08	0.08	9.10	71	10.635	0.114	229.00	2.64	0.82
WAVE	07/09/2022 09:18	0.18	3.40	112	10.662	0.127	254.00	2.66	0.84
WAVE	07/09/2022 09:28	0.13	3.40	112	10.689	0.103	267.00	2.69	0.87
WAVE	07/09/2022 09:38	0.07	3.20	47	10.706	0.072	236.00	2.71	0.89
WAVE	07/09/2022 09:48	0.12	2.60	309	10.719	0.025	339.00	2.72	0.90
WAVE	07/09/2022 09:58	0.11	3.20	123	10.736	0.058	0.00	2.74	0.92
WAVE	07/09/2022 10:08	0.29	2.80	233	10.734	0.075	14.00	2.73	0.91
WAVE	07/09/2022 10:18	0.06	2.90	275	10.742	0.071	25.00	2.74	0.92
WAVE	07/09/2022 10:28	0.10	3.40	237	10.742	0.132	11.00	2.74	0.92
WAVE	07/09/2022 10:38	0.10	3.00	117	10.728	0.103	7.00	2.73	0.91
WAVE	07/09/2022 10:48	0.05	4.00	271	10.722	0.059	347.00	2.72	0.90
WAVE	07/09/2022 10:58	0.11	2.30	251	10.699	0.099	31.00	2.70	0.88
WAVE	07/09/2022 11:08	0.20	2.60	113	10.677	0.1	19.00	2.68	0.86
WAVE	07/09/2022 11:18	0.05	3.00	23	10.655	0.13	66.00	2.66	0.83
WAVE	07/09/2022 11:28	0.03	9.10	63	10.622	0.2	71.00	2.62	0.80
WAVE	07/09/2022 11:38	0.06	16.00	169	10.59	0.218	76.00	2.59	0.77

Name	Date Time	Significant Height(m)	Peak Time(sec)	Peak Direction (degree)	ADCP Depth(m)	Current Speed(m/s)	Current Direction (degree)	water level reference to CD	water level reference to 1.82 SHD
WAVE	07/09/2022 11:48	0.18	2.60	12	10.541	0.196	67.00	2.54	0.72
WAVE	07/09/2022 11:58	0.17	2.90	110	10.504	0.207	70.00	2.50	0.68
WAVE	07/09/2022 12:08	0.06	2.70	169	10.451	0.21	67.00	2.45	0.63
WAVE	07/09/2022 12:18	0.12	2.90	97	10.393	0.21	72.00	2.39	0.57
WAVE	07/09/2022 12:28	0.07	2.90	107	10.336	0.211	70.00	2.34	0.52
WAVE	07/09/2022 12:38	0.07	3.00	127	10.271	0.201	63.00	2.27	0.45
WAVE	07/09/2022 12:48	0.16	3.00	301	10.215	0.226	63.00	2.22	0.40
WAVE	07/09/2022 12:58	0.08	2.80	323	10.174	0.23	60.00	2.17	0.35
WAVE	07/09/2022 13:08	0.05	3.80	87	10.117	0.25	55.00	2.12	0.30
WAVE	07/09/2022 13:18	0.05	10.70	19	10.069	0.285	54.00	2.07	0.25
WAVE	07/09/2022 13:28	0.17	2.50	291	10.024	0.286	51.00	2.02	0.20
WAVE	07/09/2022 13:38	0.11	2.30	43	9.971	0.283	47.00	1.97	0.15
WAVE	07/09/2022 13:48	0.12	2.80	86	9.935	0.284	59.00	1.94	0.12
WAVE	07/09/2022 13:58	0.10	2.70	295	9.903	0.29	61.00	1.90	0.08
WAVE	07/09/2022 14:08	0.07	3.00	287	9.875	0.287	58.00	1.88	0.05
WAVE	07/09/2022 14:18	0.11	2.50	295	9.842	0.282	49.00	1.84	0.02
WAVE	07/09/2022 14:28	0.10	2.90	75	9.824	0.263	47.00	1.82	0.00
WAVE	07/09/2022 14:38	0.29	3.00	112	9.804	0.253	52.00	1.80	-0.02
WAVE	07/09/2022 14:48	0.15	2.00	71	9.792	0.211	51.00	1.79	-0.03
WAVE	07/09/2022 14:58	0.08	2.50	111	9.791	0.178	48.00	1.79	-0.03
WAVE	07/09/2022 15:08	0.10	2.50	47	9.791	0.119	45.00	1.79	-0.03
WAVE	07/09/2022 15:18	0.12	2.70	123	9.801	0.125	48.00	1.80	-0.02
WAVE	07/09/2022 15:28	0.07	2.70	191	9.818	0.07	89.00	1.82	0.00
WAVE	07/09/2022 15:38	0.09	2.60	91	9.828	0.108	45.00	1.83	0.01
WAVE	07/09/2022 15:48	0.07	2.60	123	9.849	0.111	40.00	1.85	0.03
WAVE	07/09/2022 15:58	0.19	3.60	104	9.878	0.066	35.00	1.88	0.06
WAVE	07/09/2022 16:08	0.06	3.60	143	9.91	0.028	50.00	1.91	0.09
WAVE	07/09/2022 16:18	0.12	2.70	259	9.951	0.036	305.00	1.95	0.13
WAVE	07/09/2022 16:28	0.06	10.70	95	10.001	0.012	297.00	2.00	0.18
WAVE	07/09/2022 16:38	0.10	2.50	111	10.035	0.06	312.00	2.04	0.22
WAVE	07/09/2022 16:48	0.07	2.60	103	10.08	0.108	225.00	2.08	0.26
WAVE	07/09/2022 16:58	0.07	3.60	97	10.115	0.079	223.00	2.12	0.30
WAVE	07/09/2022 17:08	0.15	3.20	243	10.158	0.03	255.00	2.16	0.34
WAVE	07/09/2022 17:18	0.08	2.80	303	10.192	0.07	209.00	2.19	0.37
WAVE	07/09/2022 17:28	0.14	2.10	95	10.223	0.039	158.00	2.22	0.40
WAVE	07/09/2022 17:38	0.04	9.10	215	10.265	0.024	97.00	2.27	0.45
WAVE	07/09/2022 17:48	0.10	3.60	139	10.302	0.06	89.00	2.30	0.48
WAVE	07/09/2022 17:58	0.16	2.50	109	10.332	0.048	111.00	2.33	0.51
WAVE	07/09/2022 18:08	0.04	16.00	239	10.364	0.048	90.00	2.36	0.54
WAVE	07/09/2022 18:18	0.18	3.60	263	10.385	0.081	75.00	2.39	0.57
WAVE	07/09/2022 18:28	0.36	3.80	266	10.393	0.116	25.00	2.39	0.57
WAVE	07/09/2022 18:38	0.04	3.00	119	10.412	0.06	91.00	2.41	0.59
WAVE	07/09/2022 18:48	0.03	9.10	23	10.43	0.117	95.00	2.43	0.61
WAVE	07/09/2022 18:58	0.13	2.50	104	10.442	0.142	86.00	2.44	0.62
WAVE	07/09/2022 19:08	0.07	2.90	159	10.462	0.151	80.00	2.46	0.64
WAVE	07/09/2022 19:18	0.06	2.80	77	10.467	0.152	87.00	2.47	0.65
WAVE	07/09/2022 19:28	0.07	2.90	287	10.477	0.159	89.00	2.48	0.66
WAVE	07/09/2022 19:38	0.07	2.10	87	10.489	0.144	82.00	2.49	0.67
WAVE	07/09/2022 19:48	0.06	2.80	115	10.495	0.156	77.00	2.50	0.67
WAVE	07/09/2022 19:58	0.09	2.20	359	10.501	0.146	80.00	2.50	0.68
WAVE	07/09/2022 20:08	0.07	2.40	213	10.511	0.142	85.00	2.51	0.69
WAVE	07/09/2022 20:18	0.06	10.70	51	10.505	0.152	81.00	2.51	0.69
WAVE	07/09/2022 20:28	0.08	10.70	169	10.506	0.141	75.00	2.51	0.69
WAVE	07/09/2022 20:38	0.10	2.10	45	10.51	0.133	77.00	2.51	0.69
WAVE	07/09/2022 20:48	0.10	2.60	343	10.491	0.144	99.00	2.49	0.67
WAVE	07/09/2022 20:58	0.08	2.50	77	10.485	0.143	100.00	2.49	0.66
WAVE	07/09/2022 21:08	0.05	6.40	351	10.463	0.153	102.00	2.46	0.64
WAVE	07/09/2022 21:18	0.08	3.40	107	10.441	0.16	98.00	2.44	0.62
WAVE	07/09/2022 21:28	0.08	2.30	315	10.416	0.17	89.00	2.42	0.60
WAVE	07/09/2022 21:38	0.06	3.00	263	10.392	0.197	80.00	2.39	0.57
WAVE	07/09/2022 21:48	0.11	2.80	99	10.356	0.235	82.00	2.36	0.54
WAVE	07/09/2022 21:58	0.03	9.10	71	10.307	0.244	76.00	2.31	0.49
WAVE	07/09/2022 22:08	0.05	12.80	169	10.264	0.25	74.00	2.26	0.44
WAVE	07/09/2022 22:18	0.05	10.70	255	10.21	0.267	76.00	2.21	0.39

Name	Date Time	Significant Height(m)	Peak Time(sec)	Peak Direction (degree)	ADCP Depth(m)	Current Speed(m/s)	Current Direction (degree)	water level reference to CD	water level reference to 1.82 SHD
WAVE	07/09/2022 22:28	0.05	10.70	169	10.147	0.291	74.00	2.15	0.33
WAVE	07/09/2022 22:38	0.09	4.00	151	10.089	0.314	79.00	2.09	0.27
WAVE	07/09/2022 22:48	0.03	16.00	205	10.026	0.338	72.00	2.03	0.21
WAVE	07/09/2022 22:58	0.07	2.70	99	9.959	0.296	79.00	1.96	0.14
WAVE	07/09/2022 23:08	0.07	9.10	169	9.896	0.356	69.00	1.90	0.08
WAVE	07/09/2022 23:18	0.07	2.60	323	9.815	0.357	69.00	1.82	-0.01
WAVE	07/09/2022 23:28	0.04	9.10	269	9.742	0.373	67.00	1.74	-0.08
WAVE	07/09/2022 23:38	0.09	3.40	139	9.66	0.386	64.00	1.66	-0.16
WAVE	07/09/2022 23:48	0.07	12.80	11	9.565	0.358	62.00	1.57	-0.26
WAVE	07/09/2022 23:58	0.05	4.60	139	9.482	0.294	68.00	1.48	-0.34
WAVE	08/09/2022 00:08	0.06	9.10	169	9.397	0.302	64.00	1.40	-0.42
WAVE	08/09/2022 00:18	0.05	12.80	169	9.311	0.272	72.00	1.31	-0.51
WAVE	08/09/2022 00:28	0.04	6.40	59	9.217	0.295	62.00	1.22	-0.60
WAVE	08/09/2022 00:38	0.04	10.70	169	9.131	0.328	60.00	1.13	-0.69
WAVE	08/09/2022 00:48	0.07	2.70	103	9.042	0.362	53.00	1.04	-0.78
WAVE	08/09/2022 00:58	0.08	2.40	75	8.96	0.442	50.00	0.96	-0.86
WAVE	08/09/2022 01:08	0.04	3.00	223	8.881	0.377	48.00	0.88	-0.94
WAVE	08/09/2022 01:18	0.14	2.10	253	8.799	0.411	47.00	0.80	-1.02
WAVE	08/09/2022 01:28	0.03	9.10	207	8.727	0.427	46.00	0.73	-1.09
WAVE	08/09/2022 01:38	0.03	10.70	223	8.656	0.32	46.00	0.66	-1.16
WAVE	08/09/2022 01:48	0.07	3.80	91	8.595	0.384	44.00	0.60	-1.23
WAVE	08/09/2022 01:58	0.04	3.40	169	8.551	0.281	44.00	0.55	-1.27
WAVE	08/09/2022 02:08	0.03	10.70	163	8.507	0.268	39.00	0.51	-1.31
WAVE	08/09/2022 02:18	0.03	12.80	359	8.487	0.212	49.00	0.49	-1.33
WAVE	08/09/2022 02:28	0.06	3.60	259	8.475	0.203	47.00	0.48	-1.35
WAVE	08/09/2022 02:38	0.03	12.80	335	8.464	0.102	61.00	0.46	-1.36
WAVE	08/09/2022 02:48	0.19	1.90	155	8.449	0.18	45.00	0.45	-1.37
WAVE	08/09/2022 02:58	0.11	2.20	275	8.451	0.013	87.00	0.45	-1.37
WAVE	08/09/2022 03:08	0.07	3.40	103	8.39	0.043	40.00	0.39	-1.43
WAVE	08/09/2022 03:18	0.10	1.90	169	8.406	0.033	176.00	0.41	-1.41
WAVE	08/09/2022 03:28	0.10	3.40	103	8.417	0.029	240.00	0.42	-1.40
WAVE	08/09/2022 03:38	0.03	12.80	169	8.435	0.074	217.00	0.44	-1.39
WAVE	08/09/2022 03:48	0.07	2.10	91	8.465	0.108	221.00	0.47	-1.36
WAVE	08/09/2022 03:58	0.05	21.30	35	8.495	0.164	228.00	0.49	-1.33
WAVE	08/09/2022 04:08	0.07	2.30	161	8.534	0.197	237.00	0.53	-1.29
WAVE	08/09/2022 04:18	0.03	16.00	287	8.571	0.227	245.00	0.57	-1.25
WAVE	08/09/2022 04:28	0.07	9.10	351	8.615	0.237	255.00	0.62	-1.21
WAVE	08/09/2022 04:38	0.03	9.10	235	8.667	0.295	258.00	0.67	-1.15
WAVE	08/09/2022 04:48	0.03	9.10	219	8.727	0.303	261.00	0.73	-1.09
WAVE	08/09/2022 04:58	0.06	12.80	59	8.788	0.347	265.00	0.79	-1.03
WAVE	08/09/2022 05:08	0.05	4.30	59	8.854	0.316	261.00	0.85	-0.97
WAVE	08/09/2022 05:18	0.05	21.30	243	8.93	0.316	265.00	0.93	-0.89
WAVE	08/09/2022 05:28	0.02	9.10	163	8.997	0.346	263.00	1.00	-0.82
WAVE	08/09/2022 05:38	0.04	9.10	119	9.072	0.328	261.00	1.07	-0.75
WAVE	08/09/2022 05:48	0.07	2.80	91	9.152	0.394	262.00	1.15	-0.67
WAVE	08/09/2022 05:58	0.09	2.70	89	9.241	0.407	262.00	1.24	-0.58
WAVE	08/09/2022 06:08	0.05	4.00	123	9.322	0.361	253.00	1.32	-0.50
WAVE	08/09/2022 06:18	0.06	9.10	291	9.402	0.352	263.00	1.40	-0.42
WAVE	08/09/2022 06:28	0.05	7.10	169	9.474	0.352	263.00	1.47	-0.35
WAVE	08/09/2022 06:38	0.06	3.00	87	9.552	0.324	259.00	1.55	-0.27
WAVE	08/09/2022 06:48	0.07	4.00	79	9.627	0.315	266.00	1.63	-0.19
WAVE	08/09/2022 06:58	0.14	2.50	115	9.701	0.283	263.00	1.70	-0.12
WAVE	08/09/2022 07:08	0.09	2.10	169	9.777	0.218	269.00	1.78	-0.04
WAVE	08/09/2022 07:18	0.08	2.20	155	9.858	0.206	258.00	1.86	0.04
WAVE	08/09/2022 07:28	0.16	3.60	139	9.926	0.196	263.00	1.93	0.11
WAVE	08/09/2022 07:38	0.10	2.60	96	10.002	0.286	262.00	2.00	0.18
WAVE	08/09/2022 07:48	0.06	4.00	239	10.081	0.312	264.00	2.08	0.26
WAVE	08/09/2022 07:58	0.09	2.70	127	10.147	0.181	277.00	2.15	0.33
WAVE	08/09/2022 08:08	0.05	4.60	259	10.223	0.157	276.00	2.22	0.40
WAVE	08/09/2022 08:18	0.11	2.80	267	10.296	0.165	280.00	2.30	0.48
WAVE	08/09/2022 08:28	0.11	2.50	127	10.367	0.238	263.00	2.37	0.55
WAVE	08/09/2022 08:38	0.07	3.20	239	10.443	0.239	250.00	2.44	0.62
WAVE	08/09/2022 08:48	0.06	3.00	319	10.496	0.221	255.00	2.50	0.68
WAVE	08/09/2022 08:58	0.07	2.50	83	10.562	0.203	257.00	2.56	0.74

Name	Date Time	Significant Height(m)	Peak Time(sec)	Peak Direction (degree)	ADCP Depth(m)	Current Speed(m/s)	Current Direction (degree)	water level reference to CD	water level reference to 1.82 SHD
WAVE	08/09/2022 09:08	0.05	3.60	123	10.614	0.194	253.00	2.61	0.79
WAVE	08/09/2022 09:18	0.20	2.10	275	10.669	0.17	255.00	2.67	0.85
WAVE	08/09/2022 09:28	0.11	2.80	35	10.724	0.194	258.00	2.72	0.90
WAVE	08/09/2022 09:38	0.06	3.80	163	10.766	0.135	263.00	2.77	0.95
WAVE	08/09/2022 09:48	0.24	2.90	118	10.806	0.146	260.00	2.81	0.99
WAVE	08/09/2022 09:58	0.14	2.50	121	10.844	0.122	263.00	2.84	1.02
WAVE	08/09/2022 10:08	0.17	2.90	112	10.874	0.062	267.00	2.87	1.05
WAVE	08/09/2022 10:18	0.14	2.00	335	10.889	0.05	294.00	2.89	1.07
WAVE	08/09/2022 10:28	0.06	3.00	139	10.905	0.025	265.00	2.91	1.09
WAVE	08/09/2022 10:38	0.10	2.70	93	10.917	0.065	249.00	2.92	1.10
WAVE	08/09/2022 10:48	0.13	2.70	109	10.926	0.034	124.00	2.93	1.11
WAVE	08/09/2022 10:58	0.12	2.60	141	10.922	0.063	74.00	2.92	1.10
WAVE	08/09/2022 11:08	0.06	3.20	119	10.924	0.144	54.00	2.92	1.10
WAVE	08/09/2022 11:18	0.29	2.90	106	10.91	0.128	74.00	2.91	1.09
WAVE	08/09/2022 11:28	0.05	3.60	107	10.9	0.172	83.00	2.90	1.08
WAVE	08/09/2022 11:51	0.14	2.90	324	10.846	0.122	107.00	2.85	1.03
WAVE	08/09/2022 12:01	0.09	3.20	119	10.822	0.215	88.00	2.82	1.00
WAVE	08/09/2022 12:11	0.07	3.40	111	10.788	0.206	77.00	2.79	0.97
WAVE	08/09/2022 12:21	0.10	2.70	323	10.74	0.253	77.00	2.74	0.92
WAVE	08/09/2022 12:31	0.10	3.00	135	10.697	0.257	76.00	2.70	0.88
WAVE	08/09/2022 12:41	0.15	2.70	298	10.644	0.287	70.00	2.64	0.82
WAVE	08/09/2022 12:51	0.09	2.90	102	10.59	0.283	65.00	2.59	0.77
WAVE	08/09/2022 13:01	0.13	2.80	290	10.536	0.283	71.00	2.54	0.72
WAVE	08/09/2022 13:11	0.07	3.60	107	10.475	0.269	67.00	2.48	0.66
WAVE	08/09/2022 13:21	0.06	3.20	91	10.411	0.268	65.00	2.41	0.59
WAVE	08/09/2022 13:31	0.20	1.90	355	10.336	0.313	69.00	2.34	0.52
WAVE	08/09/2022 13:41	0.05	3.60	351	10.263	0.303	65.00	2.26	0.44
WAVE	08/09/2022 13:51	0.10	3.40	87	10.194	0.28	67.00	2.19	0.37
WAVE	08/09/2022 14:01	0.09	3.20	91	10.119	0.26	51.00	2.12	0.30
WAVE	08/09/2022 14:11	0.14	4.30	98	10.055	0.33	58.00	2.06	0.24
WAVE	08/09/2022 14:21	0.20	3.00	115	10.005	0.256	63.00	2.01	0.19
WAVE	08/09/2022 14:31	0.13	2.10	93	9.941	0.181	58.00	1.94	0.12
WAVE	08/09/2022 14:41	0.20	2.90	111	9.897	0.211	56.00	1.90	0.08
WAVE	08/09/2022 14:51	0.14	3.60	72	9.833	0.31	59.00	1.83	0.01
WAVE	08/09/2022 15:01	0.14	3.40	93	9.788	0.325	57.00	1.79	-0.03
WAVE	08/09/2022 15:11	0.08	3.60	95	9.76	0.367	50.00	1.76	-0.06
WAVE	08/09/2022 15:21	0.13	2.60	278	9.723	0.292	57.00	1.72	-0.10
WAVE	08/09/2022 15:31	0.15	4.00	100	9.704	0.238	69.00	1.70	-0.12
WAVE	08/09/2022 15:41	0.13	3.20	87	9.683	0.217	75.00	1.68	-0.14
WAVE	08/09/2022 15:51	0.09	2.30	89	9.685	0.186	64.00	1.69	-0.14
WAVE	08/09/2022 16:01	0.08	2.70	187	9.684	0.141	87.00	1.68	-0.14
WAVE	08/09/2022 16:11	0.08	2.90	169	9.697	0.081	83.00	1.70	-0.12
WAVE	08/09/2022 16:21	0.21	2.90	288	9.723	0.036	70.00	1.72	-0.10
WAVE	08/09/2022 16:31	0.03	16.00	119	9.745	0.026	177.00	1.75	-0.08
WAVE	08/09/2022 16:41	0.11	2.70	87	9.78	0.06	207.00	1.78	-0.04
WAVE	08/09/2022 16:51	0.14	2.30	267	9.813	0.116	220.00	1.81	-0.01
WAVE	08/09/2022 17:01	0.06	4.60	123	9.85	0.089	218.00	1.85	0.03
WAVE	08/09/2022 17:11	0.24	2.30	198	9.889	0.125	231.00	1.89	0.07
WAVE	08/09/2022 17:21	0.17	3.00	281	9.927	0.175	255.00	1.93	0.11
WAVE	08/09/2022 17:31	0.11	2.00	111	9.979	0.18	250.00	1.98	0.16
WAVE	08/09/2022 17:41	0.12	2.10	95	10.027	0.204	277.00	2.03	0.21
WAVE	08/09/2022 17:51	0.13	2.80	128	10.082	0.191	266.00	2.08	0.26
WAVE	08/09/2022 18:01	0.09	2.60	99	10.135	0.199	263.00	2.14	0.32
WAVE	08/09/2022 18:11	0.09	2.30	215	10.196	0.141	238.00	2.20	0.38
WAVE	08/09/2022 18:21	0.14	3.00	293	10.245	0.111	240.00	2.25	0.42
WAVE	08/09/2022 18:31	0.10	2.60	283	10.292	0.13	242.00	2.29	0.47
WAVE	08/09/2022 18:41	0.04	10.70	331	10.34	0.13	231.00	2.34	0.52
WAVE	08/09/2022 18:51	0.08	2.10	91	10.388	0.111	238.00	2.39	0.57
WAVE	08/09/2022 19:01	0.13	2.90	106	10.425	0.104	236.00	2.43	0.61
WAVE	08/09/2022 19:11	0.05	10.70	87	10.474	0.129	262.00	2.47	0.65
WAVE	08/09/2022 19:21	0.09	2.60	211	10.514	0.135	262.00	2.51	0.69
WAVE	08/09/2022 19:31	0.06	4.00	267	10.549	0.134	264.00	2.55	0.73
WAVE	08/09/2022 19:41	0.07	3.60	219	10.58	0.144	270.00	2.58	0.76
WAVE	08/09/2022 19:51	0.06	2.90	95	10.61	0.132	271.00	2.61	0.79

Name	Date Time	Significant Height(m)	Peak Time(sec)	Peak Direction (degree)	ADCP Depth(m)	Current Speed(m/s)	Current Direction (degree)	water level reference to CD	water level reference to 1.82 SHD
WAVE	08/09/2022 20:01	0.06	10.70	39	10.64	0.092	256.00	2.64	0.82
WAVE	08/09/2022 20:11	0.11	3.40	99	10.671	0.095	247.00	2.67	0.85
WAVE	08/09/2022 20:21	0.04	12.80	107	10.695	0.06	257.00	2.70	0.88
WAVE	08/09/2022 20:31	0.09	3.00	259	10.729	0.069	252.00	2.73	0.91
WAVE	08/09/2022 20:41	0.10	2.50	100	10.748	0.08	288.00	2.75	0.93
WAVE	08/09/2022 20:51	0.08	2.90	247	10.777	0.065	307.00	2.78	0.96
WAVE	08/09/2022 21:01	0.07	2.80	111	10.788	0.058	316.00	2.79	0.97
WAVE	08/09/2022 21:11	0.03	21.30	169	10.799	0.037	300.00	2.80	0.98
WAVE	08/09/2022 21:21	0.03	16.00	119	10.811	0.044	276.00	2.81	0.99
WAVE	08/09/2022 21:31	0.08	2.60	167	10.819	0.017	13.00	2.82	1.00
WAVE	08/09/2022 21:41	0.06	3.20	147	10.819	0.008	345.00	2.82	1.00
WAVE	08/09/2022 21:51	0.02	12.80	123	10.806	0.049	44.00	2.81	0.99
WAVE	08/09/2022 22:01	0.04	9.10	31	10.806	0.07	45.00	2.81	0.99
WAVE	08/09/2022 22:11	0.06	9.10	107	10.79	0.119	79.00	2.79	0.97
WAVE	08/09/2022 22:21	0.09	9.10	169	10.769	0.143	85.00	2.77	0.95
WAVE	08/09/2022 22:31	0.08	2.60	171	10.742	0.162	77.00	2.74	0.92
WAVE	08/09/2022 22:41	0.09	2.20	169	10.701	0.166	73.00	2.70	0.88
WAVE	08/09/2022 22:51	0.07	2.40	263	10.654	0.239	77.00	2.65	0.83
WAVE	08/09/2022 23:01	0.07	2.40	291	10.598	0.276	69.00	2.60	0.78
WAVE	08/09/2022 23:11	0.07	2.70	95	10.545	0.272	69.00	2.55	0.73
WAVE	08/09/2022 23:21	0.07	4.30	83	10.474	0.315	72.00	2.47	0.65
WAVE	08/09/2022 23:31	0.05	9.10	343	10.401	0.361	68.00	2.40	0.58
WAVE	08/09/2022 23:41	0.05	9.10	55	10.323	0.345	72.00	2.32	0.50
WAVE	08/09/2022 23:51	0.07	2.50	205	10.232	0.369	66.00	2.23	0.41
WAVE	09/09/2022 00:01	0.04	10.70	339	10.132	0.372	68.00	2.13	0.31
WAVE	09/09/2022 00:11	0.03	21.30	227	10.037	0.314	72.00	2.04	0.22
WAVE	09/09/2022 00:21	0.05	21.30	143	9.941	0.313	71.00	1.94	0.12
WAVE	09/09/2022 00:31	0.06	8.00	327	9.843	0.343	61.00	1.84	0.02
WAVE	09/09/2022 00:41	0.05	3.40	227	9.748	0.237	70.00	1.75	-0.07
WAVE	09/09/2022 00:51	0.06	16.00	169	9.652	0.332	84.00	1.65	-0.17
WAVE	09/09/2022 01:01	0.06	3.60	287	9.556	0.3	87.00	1.56	-0.26
WAVE	09/09/2022 01:11	0.04	16.00	215	9.449	0.24	83.00	1.45	-0.37
WAVE	09/09/2022 01:21	0.04	5.30	339	9.34	0.256	87.00	1.34	-0.48
WAVE	09/09/2022 01:31	0.06	12.80	23	9.236	0.296	87.00	1.24	-0.58
WAVE	09/09/2022 01:41	0.27	2.70	216	9.122	0.256	88.00	1.12	-0.70
WAVE	09/09/2022 01:51	0.07	2.50	91	9.016	0.147	98.00	1.02	-0.80
WAVE	09/09/2022 02:01	0.07	3.00	195	8.924	0.157	96.00	0.92	-0.90
WAVE	09/09/2022 02:11	0.06	3.60	79	8.834	0.144	82.00	0.83	-0.99
WAVE	09/09/2022 02:21	0.06	10.70	169	8.743	0.1	99.00	0.74	-1.08
WAVE	09/09/2022 02:31	0.13	2.60	153	8.662	0.211	59.00	0.66	-1.16
WAVE	09/09/2022 02:41	0.03	10.70	167	8.575	0.455	45.00	0.57	-1.25
WAVE	09/09/2022 02:51	0.13	2.10	59	8.495	0.396	41.00	0.49	-1.33
WAVE	09/09/2022 03:01	0.07	3.80	99	8.423	0.279	32.00	0.42	-1.40
WAVE	09/09/2022 03:11	0.04	12.80	169	8.363	0.199	26.00	0.36	-1.46
WAVE	09/09/2022 03:21	0.04	21.30	79	8.324	0.095	346.00	0.32	-1.50
WAVE	09/09/2022 03:31	0.05	2.40	155	8.296	0.074	315.00	0.30	-1.52
WAVE	09/09/2022 03:41	0.04	12.80	169	8.278	0.098	323.00	0.28	-1.54
WAVE	09/09/2022 03:51	0.05	3.60	87	8.223	0.073	277.00	0.22	-1.60
WAVE	09/09/2022 04:01	0.06	3.00	95	8.219	0.102	311.00	0.22	-1.60
WAVE	09/09/2022 04:11	0.03	10.70	271	8.223	0.084	326.00	0.22	-1.60
WAVE	09/09/2022 04:21	0.05	10.70	39	8.245	0.104	298.00	0.24	-1.58
WAVE	09/09/2022 04:31	0.05	9.10	103	8.262	0.12	277.00	0.26	-1.56
WAVE	09/09/2022 04:41	0.07	3.20	79	8.29	0.154	281.00	0.29	-1.53
WAVE	09/09/2022 04:51	0.04	8.00	267	8.322	0.182	272.00	0.32	-1.50
WAVE	09/09/2022 05:01	0.05	5.80	119	8.376	0.211	263.00	0.38	-1.44
WAVE	09/09/2022 05:11	0.05	2.90	55	8.431	0.271	254.00	0.43	-1.39
WAVE	09/09/2022 05:21	0.08	2.70	91	8.484	0.289	254.00	0.48	-1.34
WAVE	09/09/2022 05:31	0.10	2.70	243	8.549	0.304	256.00	0.55	-1.27
WAVE	09/09/2022 05:41	0.12	4.00	87	8.623	0.463	260.00	0.62	-1.20
WAVE	09/09/2022 05:51	0.07	3.60	89	8.711	0.465	264.00	0.71	-1.11
WAVE	09/09/2022 06:01	0.12	2.80	119	8.778	0.547	265.00	0.78	-1.04
WAVE	09/09/2022 06:11	0.03	9.10	243	8.865	0.422	263.00	0.87	-0.96
WAVE	09/09/2022 06:21	0.05	7.10	107	8.951	0.42	270.00	0.95	-0.87
WAVE	09/09/2022 06:31	0.03	9.10	23	9.039	0.408	271.00	1.04	-0.78

Name	Date Time	Significant Height(m)	Peak Time(sec)	Peak Direction (degree)	ADCP Depth(m)	Current Speed(m/s)	Current Direction (degree)	water level reference to CD	water level reference to 1.82 SHD
WAVE	09/09/2022 06:41	0.08	3.20	219	9.127	0.429	262.00	1.13	-0.69
WAVE	09/09/2022 06:51	0.03	9.10	283	9.228	0.452	261.00	1.23	-0.59
WAVE	09/09/2022 07:01	0.08	2.10	7	9.323	0.368	258.00	1.32	-0.50
WAVE	09/09/2022 07:11	0.14	2.90	282	9.41	0.355	261.00	1.41	-0.41
WAVE	09/09/2022 07:21	0.09	2.10	315	9.493	0.322	256.00	1.49	-0.33
WAVE	09/09/2022 07:31	0.05	6.40	135	9.582	0.392	258.00	1.58	-0.24
WAVE	09/09/2022 07:41	0.08	2.70	283	9.664	0.38	272.00	1.66	-0.16
WAVE	09/09/2022 07:51	0.07	12.80	3	9.753	0.386	265.00	1.75	-0.07
WAVE	09/09/2022 08:01	0.05	16.00	39	9.838	0.377	263.00	1.84	0.02
WAVE	09/09/2022 08:11	0.07	2.60	351	9.915	0.334	258.00	1.92	0.09
WAVE	09/09/2022 08:21	0.05	3.20	259	10.002	0.357	257.00	2.00	0.18
WAVE	09/09/2022 08:31	0.10	2.00	111	10.079	0.387	253.00	2.08	0.26
WAVE	09/09/2022 08:41	0.39	3.00	292	10.162	0.335	257.00	2.16	0.34
WAVE	09/09/2022 08:51	0.05	21.30	169	10.238	0.331	256.00	2.24	0.42
WAVE	09/09/2022 09:01	0.13	3.00	239	10.292	0.316	259.00	2.29	0.47
WAVE	09/09/2022 09:11	0.18	2.10	129	10.396	0.293	256.00	2.40	0.58
WAVE	09/09/2022 09:21	0.17	2.70	103	10.466	0.28	249.00	2.47	0.65
WAVE	09/09/2022 09:31	0.16	2.00	291	10.534	0.262	248.00	2.53	0.71
WAVE	09/09/2022 09:41	0.11	2.30	199	10.606	0.258	251.00	2.61	0.79
WAVE	09/09/2022 09:51	0.31	2.70	125	10.674	0.309	257.00	2.67	0.85
WAVE	09/09/2022 10:01	0.17	2.60	123	10.733	0.202	236.00	2.73	0.91
WAVE	09/09/2022 10:11	0.07	3.20	241	10.792	0.198	263.00	2.79	0.97
WAVE	09/09/2022 10:21	0.12	2.70	119	10.845	0.241	264.00	2.85	1.03
WAVE	09/09/2022 10:31	0.13	4.00	138	10.898	0.219	248.00	2.90	1.08
WAVE	09/09/2022 10:41	0.10	2.30	353	10.935	0.204	247.00	2.94	1.12
WAVE	09/09/2022 10:51	0.08	2.40	35	10.982	0.133	257.00	2.98	1.16
WAVE	09/09/2022 11:01	0.11	2.90	103	11.001	0.075	260.00	3.00	1.18
WAVE	09/09/2022 11:11	0.06	10.70	243	11.02	0.018	82.00	3.02	1.20
WAVE	09/09/2022 11:21	0.12	2.70	305	11.036	0.051	45.00	3.04	1.22
WAVE	09/09/2022 11:31	0.14	2.60	177	11.034	0.099	72.00	3.03	1.21
WAVE	09/09/2022 11:41	0.09	2.90	83	11.031	0.132	45.00	3.03	1.21
WAVE	09/09/2022 11:51	0.20	1.90	95	11.024	0.152	56.00	3.02	1.20
WAVE	09/09/2022 12:01	0.07	2.90	133	11.007	0.177	77.00	3.01	1.19
WAVE	09/09/2022 12:11	0.12	2.90	234	10.974	0.278	56.00	2.97	1.15
WAVE	09/09/2022 12:21	0.06	3.00	99	10.934	0.332	71.00	2.93	1.11
WAVE	09/09/2022 12:31	0.17	2.60	23	10.9	0.341	73.00	2.90	1.08
WAVE	09/09/2022 12:41	0.10	3.20	124	10.857	0.303	76.00	2.86	1.04
WAVE	09/09/2022 12:51	0.06	3.60	95	10.808	0.338	72.00	2.81	0.99
WAVE	09/09/2022 13:01	0.10	2.80	3	10.748	0.331	72.00	2.75	0.93
WAVE	09/09/2022 13:11	0.20	2.60	288	10.696	0.372	74.00	2.70	0.88
WAVE	09/09/2022 13:21	0.09	2.60	63	10.627	0.365	74.00	2.63	0.81
WAVE	09/09/2022 13:31	0.09	2.40	344	10.563	0.292	87.00	2.56	0.74
WAVE	09/09/2022 13:41	0.07	9.10	169	10.48	0.33	83.00	2.48	0.66
WAVE	09/09/2022 13:51	0.08	10.70	169	10.401	0.287	84.00	2.40	0.58
WAVE	09/09/2022 14:01	0.05	9.10	259	10.312	0.261	96.00	2.31	0.49
WAVE	09/09/2022 14:11	0.11	2.80	91	10.225	0.267	104.00	2.23	0.41
WAVE	09/09/2022 14:21	0.08	2.60	259	10.151	0.205	68.00	2.15	0.33
WAVE	09/09/2022 14:31	0.12	2.80	80	10.064	0.201	79.00	2.06	0.24
WAVE	09/09/2022 14:41	0.07	2.20	15	9.986	0.281	80.00	1.99	0.17
WAVE	09/09/2022 14:51	0.08	2.60	103	9.897	0.213	85.00	1.90	0.08
WAVE	09/09/2022 15:01	0.17	2.90	87	9.829	0.153	58.00	1.83	0.01
WAVE	09/09/2022 15:11	0.05	8.00	255	9.744	0.183	49.00	1.74	-0.08
WAVE	09/09/2022 15:21	0.09	2.60	81	9.687	0.17	53.00	1.69	-0.13
WAVE	09/09/2022 15:31	0.19	2.90	171	9.616	0.154	60.00	1.62	-0.20
WAVE	09/09/2022 15:41	0.12	4.00	95	9.559	0.379	54.00	1.56	-0.26
WAVE	09/09/2022 15:51	0.15	4.00	84	9.51	0.398	45.00	1.51	-0.31
WAVE	09/09/2022 16:01	0.11	2.70	106	9.479	0.34	41.00	1.48	-0.34
WAVE	09/09/2022 16:11	0.09	2.10	43	9.443	0.287	35.00	1.44	-0.38
WAVE	09/09/2022 16:21	0.16	2.60	287	9.426	0.243	34.00	1.43	-0.39
WAVE	09/09/2022 16:31	0.05	3.60	115	9.419	0.175	33.00	1.42	-0.40
WAVE	09/09/2022 16:41	0.14	2.70	273	9.427	0.129	38.00	1.43	-0.39
WAVE	09/09/2022 16:51	0.09	2.60	79	9.432	0.058	26.00	1.43	-0.39
WAVE	09/09/2022 17:01	0.11	2.10	255	9.45	0.013	209.00	1.45	-0.37
WAVE	09/09/2022 17:11	0.14	2.80	302	9.478	0.084	230.00	1.48	-0.34

Name	Date Time	Significant Height(m)	Peak Time(sec)	Peak Direction (degree)	ADCP Depth(m)	Current Speed(m/s)	Current Direction (degree)	water level reference to CD	water level reference to 1.82 SHD
WAVE	09/09/2022 17:21	0.08	2.30	211	9.514	0.101	244.00	1.51	-0.31
WAVE	09/09/2022 17:31	0.03	10.70	211	9.555	0.153	234.00	1.56	-0.27
WAVE	09/09/2022 17:41	0.16	2.60	107	9.595	0.175	250.00	1.60	-0.22
WAVE	09/09/2022 17:51	0.14	2.80	102	9.649	0.209	252.00	1.65	-0.17
WAVE	09/09/2022 18:01	0.12	2.20	93	9.691	0.228	256.00	1.69	-0.13
WAVE	09/09/2022 18:11	0.06	9.10	311	9.747	0.23	257.00	1.75	-0.07
WAVE	09/09/2022 18:21	0.14	2.80	127	9.81	0.212	258.00	1.81	-0.01
WAVE	09/09/2022 18:31	0.06	3.00	83	9.872	0.246	260.00	1.87	0.05
WAVE	09/09/2022 18:41	0.06	4.60	123	9.944	0.216	261.00	1.94	0.12
WAVE	09/09/2022 18:51	0.09	2.80	311	10.008	0.25	261.00	2.01	0.19
WAVE	09/09/2022 19:01	0.12	2.60	231	10.093	0.285	261.00	2.09	0.27
WAVE	09/09/2022 19:11	0.11	3.40	112	10.154	0.272	252.00	2.15	0.33
WAVE	09/09/2022 19:21	0.20	2.30	315	10.207	0.238	257.00	2.21	0.39
WAVE	09/09/2022 19:31	0.11	3.40	117	10.28	0.215	278.00	2.28	0.46
WAVE	09/09/2022 19:41	0.07	4.00	249	10.349	0.187	261.00	2.35	0.53
WAVE	09/09/2022 19:51	0.09	2.60	143	10.421	0.223	268.00	2.42	0.60
WAVE	09/09/2022 20:01	0.10	3.20	232	10.49	0.2	252.00	2.49	0.67
WAVE	09/09/2022 20:11	0.06	3.60	199	10.542	0.177	257.00	2.54	0.72
WAVE	09/09/2022 20:21	0.07	3.40	259	10.611	0.187	262.00	2.61	0.79
WAVE	09/09/2022 20:31	0.07	10.70	135	10.655	0.169	243.00	2.66	0.83
WAVE	09/09/2022 20:41	0.04	12.80	75	10.703	0.124	246.00	2.70	0.88
WAVE	09/09/2022 20:51	0.01	21.30	295	10.744	0.096	257.00	2.74	0.92
WAVE	09/09/2022 21:01	0.03	16.00	35	10.777	0.106	255.00	2.78	0.96
WAVE	09/09/2022 21:11	0.08	3.20	91	10.835	0.078	268.00	2.84	1.02
WAVE	09/09/2022 21:21	0.08	9.10	115	10.877	0.061	247.00	2.88	1.06
WAVE	09/09/2022 21:31	0.09	2.60	345	10.914	0.049	284.00	2.91	1.09
WAVE	09/09/2022 21:41	0.04	16.00	169	10.947	0.01	263.00	2.95	1.13
WAVE	09/09/2022 21:51	0.09	2.50	121	10.969	0.009	353.00	2.97	1.15
WAVE	09/09/2022 22:01	0.02	12.80	327	10.987	0.029	39.00	2.99	1.17
WAVE	09/09/2022 22:11	0.07	9.10	169	10.998	0.03	6.00	3.00	1.18
WAVE	09/09/2022 22:21	0.06	10.70	27	11.005	0.033	34.00	3.01	1.19
WAVE	09/09/2022 22:31	0.05	3.60	111	11.009	0.016	68.00	3.01	1.19
WAVE	09/09/2022 22:41	0.07	2.80	229	11.015	0.053	33.00	3.02	1.20
WAVE	09/09/2022 22:51	0.08	2.20	59	11.007	0.064	67.00	3.01	1.19
WAVE	09/09/2022 23:01	0.05	9.10	139	10.995	0.083	75.00	3.00	1.18
WAVE	09/09/2022 23:11	0.04	12.80	251	10.975	0.118	46.00	2.98	1.16
WAVE	09/09/2022 23:21	0.06	10.70	123	10.944	0.181	61.00	2.94	1.12
WAVE	09/09/2022 23:31	0.05	16.00	163	10.884	0.215	74.00	2.88	1.06
WAVE	09/09/2022 23:41	0.10	9.10	283	10.855	0.191	71.00	2.86	1.04
WAVE	09/09/2022 23:51	0.05	10.70	71	10.79	0.226	76.00	2.79	0.97
WAVE	10/09/2022 00:01	0.05	10.70	167	10.735	0.31	73.00	2.74	0.91
WAVE	10/09/2022 00:11	0.05	12.80	319	10.665	0.35	82.00	2.67	0.84
WAVE	10/09/2022 00:21	0.06	12.80	215	10.592	0.361	81.00	2.59	0.77
WAVE	10/09/2022 00:31	0.07	2.90	319	10.494	0.349	78.00	2.49	0.67
WAVE	10/09/2022 00:41	0.08	3.80	109	10.406	0.431	79.00	2.41	0.59
WAVE	10/09/2022 00:51	0.08	2.80	71	10.31	0.421	79.00	2.31	0.49
WAVE	10/09/2022 01:01	0.03	10.70	351	10.212	0.334	74.00	2.21	0.39
WAVE	10/09/2022 01:11	0.02	10.70	235	10.104	0.283	85.00	2.10	0.28
WAVE	10/09/2022 01:21	0.04	16.00	169	10.009	0.342	88.00	2.01	0.19
WAVE	10/09/2022 01:31	0.07	12.80	103	9.895	0.283	74.00	1.90	0.07
WAVE	10/09/2022 01:41	0.05	8.00	171	9.792	0.246	80.00	1.79	-0.03
WAVE	10/09/2022 01:51	0.04	10.70	35	9.68	0.256	85.00	1.68	-0.14
WAVE	10/09/2022 02:01	0.07	2.50	99	9.569	0.328	86.00	1.57	-0.25
WAVE	10/09/2022 02:11	0.03	9.10	243	9.453	0.313	87.00	1.45	-0.37
WAVE	10/09/2022 02:21	0.05	9.10	139	9.339	0.314	94.00	1.34	-0.48
WAVE	10/09/2022 02:31	0.06	21.30	119	9.224	0.305	90.00	1.22	-0.60
WAVE	10/09/2022 02:41	0.07	2.50	287	9.105	0.276	88.00	1.11	-0.72
WAVE	10/09/2022 02:51	0.07	2.50	283	8.994	0.252	91.00	0.99	-0.83
WAVE	10/09/2022 03:01	0.04	8.00	169	8.889	0.248	93.00	0.89	-0.93
WAVE	10/09/2022 03:11	0.06	3.40	15	8.794	0.215	85.00	0.79	-1.03
WAVE	10/09/2022 03:21	0.07	10.70	169	8.699	0.181	83.00	0.70	-1.12
WAVE	10/09/2022 03:31	0.04	7.10	279	8.607	0.171	80.00	0.61	-1.21
WAVE	10/09/2022 03:41	0.06	16.00	263	8.509	0.126	85.00	0.51	-1.31
WAVE	10/09/2022 03:51	0.06	9.10	123	8.43	0.071	107.00	0.43	-1.39

Name	Date Time	Significant Height(m)	Peak Time(sec)	Peak Direction (degree)	ADCP Depth(m)	Current Speed(m/s)	Current Direction (degree)	water level reference to CD	water level reference to 1.82 SHD
WAVE	10/09/2022 04:01	0.07	9.10	55	8.362	0.041	82.00	0.36	-1.46
WAVE	10/09/2022 04:11	0.03	21.30	103	8.303	0.07	348.00	0.30	-1.52
WAVE	10/09/2022 04:21	0.04	9.10	211	8.27	0.088	289.00	0.27	-1.55
WAVE	10/09/2022 04:31	0.04	9.10	115	8.221	0.09	326.00	0.22	-1.60
WAVE	10/09/2022 04:41	0.03	10.70	139	8.203	0.128	258.00	0.20	-1.62
WAVE	10/09/2022 04:51	0.04	21.30	271	8.193	0.154	309.00	0.19	-1.63
WAVE	10/09/2022 05:01	0.09	1.70	243	8.205	0.181	308.00	0.21	-1.62
WAVE	10/09/2022 05:11	0.07	4.00	147	8.223	0.189	317.00	0.22	-1.60
WAVE	10/09/2022 05:21	0.04	12.80	171	8.241	0.146	298.00	0.24	-1.58
WAVE	10/09/2022 05:31	0.02	12.80	267	8.271	0.137	297.00	0.27	-1.55
WAVE	10/09/2022 05:41	0.06	8.00	215	8.33	0.175	271.00	0.33	-1.49
WAVE	10/09/2022 05:51	0.10	2.50	110	8.373	0.185	268.00	0.37	-1.45
WAVE	10/09/2022 06:01	0.04	10.70	131	8.428	0.183	265.00	0.43	-1.39
WAVE	10/09/2022 06:11	0.04	16.00	169	8.503	0.257	256.00	0.50	-1.32
WAVE	10/09/2022 06:21	0.03	21.30	107	8.577	0.276	254.00	0.58	-1.24
WAVE	10/09/2022 06:31	0.12	2.10	160	8.658	0.328	257.00	0.66	-1.16
WAVE	10/09/2022 06:41	0.05	3.60	303	8.726	0.314	257.00	0.73	-1.09
WAVE	10/09/2022 06:51	0.03	10.70	171	8.814	0.335	263.00	0.81	-1.01
WAVE	10/09/2022 07:01	0.09	8.00	91	8.885	0.332	269.00	0.89	-0.94
WAVE	10/09/2022 07:11	0.09	2.40	263	8.97	0.409	268.00	0.97	-0.85
WAVE	10/09/2022 07:21	0.05	9.10	111	9.07	0.328	263.00	1.07	-0.75
WAVE	10/09/2022 07:31	0.06	4.30	199	9.154	0.349	260.00	1.15	-0.67
WAVE	10/09/2022 07:41	0.04	12.80	31	9.259	0.391	265.00	1.26	-0.56
WAVE	10/09/2022 07:51	0.11	2.80	243	9.346	0.429	261.00	1.35	-0.47
WAVE	10/09/2022 08:01	0.06	9.10	143	9.441	0.411	258.00	1.44	-0.38
WAVE	10/09/2022 08:11	0.03	12.80	39	9.536	0.364	256.00	1.54	-0.28
WAVE	10/09/2022 08:21	0.07	5.30	91	9.62	0.371	255.00	1.62	-0.20
WAVE	10/09/2022 08:31	0.18	2.30	93	9.714	0.528	261.00	1.71	-0.11
WAVE	10/09/2022 08:41	0.08	3.60	127	9.806	0.476	263.00	1.81	-0.01
WAVE	10/09/2022 08:51	0.06	3.20	263	9.882	0.38	254.00	1.88	0.06
WAVE	10/09/2022 09:01	0.25	2.90	125	9.988	0.384	264.00	1.99	0.17
WAVE	10/09/2022 09:11	0.07	3.20	277	10.073	0.369	254.00	2.07	0.25
WAVE	10/09/2022 09:21	0.21	2.60	135	10.168	0.34	251.00	2.17	0.35
WAVE	10/09/2022 09:31	0.25	2.00	235	10.252	0.349	255.00	2.25	0.43
WAVE	10/09/2022 09:41	0.08	2.90	311	10.35	0.319	253.00	2.35	0.53
WAVE	10/09/2022 09:51	0.10	2.20	271	10.434	0.284	253.00	2.43	0.61
WAVE	10/09/2022 10:01	0.22	2.70	146	10.518	0.296	249.00	2.52	0.70
WAVE	10/09/2022 10:11	0.09	10.70	169	10.586	0.301	256.00	2.59	0.77
WAVE	10/09/2022 10:21	0.06	3.20	91	10.634	0.311	253.00	2.63	0.81
WAVE	10/09/2022 10:31	0.24	2.70	267	10.713	0.244	252.00	2.71	0.89
WAVE	10/09/2022 10:41	0.08	2.90	79	10.778	0.246	248.00	2.78	0.96
WAVE	10/09/2022 10:51	0.14	2.90	254	10.826	0.228	249.00	2.83	1.01
WAVE	10/09/2022 11:01	0.13	3.20	113	10.874	0.191	245.00	2.87	1.05
WAVE	10/09/2022 11:11	0.11	2.80	113	10.916	0.151	248.00	2.92	1.10
WAVE	10/09/2022 11:21	0.10	3.00	113	10.942	0.069	191.00	2.94	1.12
WAVE	10/09/2022 11:31	0.03	21.30	283	10.975	0.075	213.00	2.98	1.16
WAVE	10/09/2022 11:41	0.12	2.20	88	10.988	0.079	54.00	2.99	1.17
WAVE	10/09/2022 11:51	0.17	2.60	286	11.005	0.108	115.00	3.01	1.19
WAVE	10/09/2022 12:01	0.06	3.80	257	11.009	0.132	70.00	3.01	1.19
WAVE	10/09/2022 12:11	0.07	2.60	223	10.991	0.236	66.00	2.99	1.17
WAVE	10/09/2022 12:21	0.27	3.00	289	10.98	0.229	53.00	2.98	1.16
WAVE	10/09/2022 12:31	0.07	2.70	99	10.959	0.324	55.00	2.96	1.14
WAVE	10/09/2022 12:41	0.35	2.90	275	10.938	0.303	49.00	2.94	1.12
WAVE	10/09/2022 12:51	0.21	2.10	125	10.905	0.296	52.00	2.91	1.09
WAVE	10/09/2022 13:01	0.06	3.60	67	10.861	0.372	63.00	2.86	1.04
WAVE	10/09/2022 13:11	0.12	3.80	89	10.82	0.412	71.00	2.82	1.00
WAVE	10/09/2022 13:21	0.07	2.80	351	10.767	0.369	68.00	2.77	0.95
WAVE	10/09/2022 13:31	0.07	3.00	359	10.705	0.372	63.00	2.71	0.89
WAVE	10/09/2022 13:41	0.07	3.60	75	10.654	0.36	75.00	2.65	0.83
WAVE	10/09/2022 13:51	0.17	2.50	138	10.59	0.369	77.00	2.59	0.77
WAVE	10/09/2022 14:01	0.23	3.20	94	10.523	0.341	78.00	2.52	0.70
WAVE	10/09/2022 14:11	0.12	2.60	7	10.445	0.338	81.00	2.45	0.63
WAVE	10/09/2022 14:21	0.10	3.20	105	10.366	0.323	83.00	2.37	0.55
WAVE	10/09/2022 14:31	0.22	2.70	293	10.277	0.329	84.00	2.28	0.46

Name	Date Time	Significant Height(m)	Peak Time(sec)	Peak Direction (degree)	ADCP Depth(m)	Current Speed(m/s)	Current Direction (degree)	water level reference to CD	water level reference to 1.82 SHD
WAVE	10/09/2022 14:41	0.13	2.40	27	10.184	0.364	93.00	2.18	0.36
WAVE	10/09/2022 14:51	0.10	2.60	71	10.096	0.343	94.00	2.10	0.28
WAVE	10/09/2022 15:01	0.11	2.10	71	10.004	0.346	94.00	2.00	0.18
WAVE	10/09/2022 15:11	0.10	2.20	131	9.918	0.344	91.00	1.92	0.10
WAVE	10/09/2022 15:35	0.03	9.10	267	9.706	0.312	81.00	1.71	-0.11
WAVE	10/09/2022 15:45	0.17	2.50	235	9.62	0.292	90.00	1.62	-0.20
WAVE	10/09/2022 15:55	0.11	2.20	355	9.54	0.304	89.00	1.54	-0.28
WAVE	10/09/2022 16:05	0.07	2.70	91	9.468	0.257	81.00	1.47	-0.35
WAVE	10/09/2022 16:15	0.13	2.40	195	9.396	0.201	82.00	1.40	-0.42
WAVE	10/09/2022 16:25	0.19	3.40	95	9.329	0.19	86.00	1.33	-0.49
WAVE	10/09/2022 16:35	0.11	3.20	114	9.283	0.135	80.00	1.28	-0.54
WAVE	10/09/2022 16:45	0.24	3.20	111	9.202	0.146	29.00	1.20	-0.62
WAVE	10/09/2022 17:08	0.04	9.10	103	9.167	0.064	31.00	1.17	-0.65
WAVE	10/09/2022 17:18	0.08	2.50	95	9.165	0.076	317.00	1.17	-0.66
WAVE	10/09/2022 17:28	0.18	2.20	323	9.18	0.094	297.00	1.18	-0.64
WAVE	10/09/2022 17:38	0.16	3.00	92	9.204	0.165	279.00	1.20	-0.62
WAVE	10/09/2022 17:48	0.22	2.90	289	9.238	0.094	291.00	1.24	-0.58
WAVE	10/09/2022 17:58	0.35	3.60	292	9.28	0.134	268.00	1.28	-0.54
WAVE	10/09/2022 18:08	0.17	2.80	100	9.324	0.209	265.00	1.32	-0.50
WAVE	10/09/2022 18:18	0.12	2.80	116	9.375	0.232	259.00	1.38	-0.45
WAVE	10/09/2022 18:28	0.21	3.60	248	9.435	0.214	254.00	1.44	-0.39
WAVE	10/09/2022 18:38	0.09	2.90	269	9.497	0.306	256.00	1.50	-0.32
WAVE	10/09/2022 18:48	0.14	2.70	125	9.566	0.336	258.00	1.57	-0.25
WAVE	10/09/2022 18:58	0.09	2.40	115	9.641	0.37	265.00	1.64	-0.18
WAVE	10/09/2022 19:08	0.07	21.30	267	9.708	0.372	267.00	1.71	-0.11
WAVE	10/09/2022 19:18	0.07	2.70	145	9.786	0.347	266.00	1.79	-0.03
WAVE	10/09/2022 19:28	0.03	21.30	79	9.862	0.388	271.00	1.86	0.04
WAVE	10/09/2022 19:38	0.10	2.30	334	9.946	0.295	260.00	1.95	0.13
WAVE	10/09/2022 19:48	0.03	16.00	79	10.012	0.284	250.00	2.01	0.19
WAVE	10/09/2022 19:58	0.07	2.80	23	10.09	0.209	240.00	2.09	0.27
WAVE	10/09/2022 20:08	0.03	10.70	169	10.162	0.235	250.00	2.16	0.34
WAVE	10/09/2022 20:18	0.16	2.20	123	10.246	0.236	266.00	2.25	0.43
WAVE	10/09/2022 20:28	0.04	12.80	139	10.323	0.232	254.00	2.32	0.50
WAVE	10/09/2022 20:38	0.15	2.50	319	10.41	0.228	245.00	2.41	0.59
WAVE	10/09/2022 20:48	0.08	10.70	103	10.489	0.211	249.00	2.49	0.67
WAVE	10/09/2022 20:58	0.05	3.20	283	10.559	0.213	244.00	2.56	0.74
WAVE	10/09/2022 21:08	0.04	16.00	55	10.637	0.202	256.00	2.64	0.82
WAVE	10/09/2022 21:18	0.07	2.40	327	10.703	0.228	253.00	2.70	0.88
WAVE	10/09/2022 21:28	0.04	9.10	43	10.767	0.242	242.00	2.77	0.95
WAVE	10/09/2022 21:38	0.08	2.80	115	10.83	0.272	246.00	2.83	1.01
WAVE	10/09/2022 21:48	0.07	8.00	63	10.895	0.253	236.00	2.90	1.08
WAVE	10/09/2022 21:58	0.03	16.00	3	10.959	0.221	233.00	2.96	1.14
WAVE	10/09/2022 22:08	0.05	9.10	333	11.014	0.284	231.00	3.01	1.19
WAVE	10/09/2022 22:18	0.07	2.20	349	11.066	0.261	228.00	3.07	1.25
WAVE	10/09/2022 22:28	0.09	2.70	299	11.119	0.227	227.00	3.12	1.30
WAVE	10/09/2022 22:38	0.05	9.10	311	11.154	0.224	233.00	3.15	1.33
WAVE	10/09/2022 22:48	0.06	3.60	87	11.194	0.229	239.00	3.19	1.37
WAVE	10/09/2022 22:58	0.07	2.70	103	11.222	0.183	235.00	3.22	1.40
WAVE	10/09/2022 23:08	0.05	9.10	27	11.243	0.16	218.00	3.24	1.42
WAVE	10/09/2022 23:18	0.07	2.80	151	11.247	0.102	222.00	3.25	1.43
WAVE	10/09/2022 23:28	0.03	12.80	123	11.256	0.04	214.00	3.26	1.44
WAVE	10/09/2022 23:38	0.04	7.10	169	11.243	0.054	147.00	3.24	1.42
WAVE	10/09/2022 23:48	0.05	16.00	231	11.218	0.192	97.00	3.22	1.40
WAVE	10/09/2022 23:58	0.05	2.70	83	11.179	0.25	93.00	3.18	1.36
WAVE	11/09/2022 00:08	0.07	2.50	235	11.146	0.292	87.00	3.15	1.33
WAVE	11/09/2022 00:18	0.09	2.30	351	11.09	0.331	82.00	3.09	1.27
WAVE	11/09/2022 00:28	0.07	16.00	7	11.031	0.416	67.00	3.03	1.21
WAVE	11/09/2022 00:38	0.05	12.80	327	10.961	0.485	69.00	2.96	1.14
WAVE	11/09/2022 00:48	0.06	3.00	83	10.888	0.492	78.00	2.89	1.07
WAVE	11/09/2022 00:58	0.06	2.10	79	10.81	0.513	79.00	2.81	0.99
WAVE	11/09/2022 01:08	0.07	9.10	95	10.723	0.511	78.00	2.72	0.90
WAVE	11/09/2022 01:18	0.09	2.30	55	10.628	0.54	74.00	2.63	0.81
WAVE	11/09/2022 01:28	0.04	9.10	163	10.53	0.366	81.00	2.53	0.71
WAVE	11/09/2022 01:38	0.03	7.10	335	10.421	0.32	81.00	2.42	0.60

Name	Date Time	Significant Height(m)	Peak Time(sec)	Peak Direction (degree)	ADCP Depth(m)	Current Speed(m/s)	Current Direction (degree)	water level reference to CD	water level reference to 1.82 SHD
WAVE	11/09/2022 01:48	0.05	12.80	271	10.312	0.344	86.00	2.31	0.49
WAVE	11/09/2022 01:58	0.07	2.50	39	10.198	0.349	86.00	2.20	0.38
WAVE	11/09/2022 02:08	0.04	21.30	263	10.083	0.323	84.00	2.08	0.26
WAVE	11/09/2022 02:18	0.04	5.80	99	9.969	0.348	91.00	1.97	0.15
WAVE	11/09/2022 02:28	0.07	2.40	75	9.853	0.34	92.00	1.85	0.03
WAVE	11/09/2022 02:38	0.04	7.10	55	9.732	0.346	87.00	1.73	-0.09
WAVE	11/09/2022 02:48	0.06	4.00	99	9.62	0.364	91.00	1.62	-0.20
WAVE	11/09/2022 02:58	0.06	3.80	79	9.504	0.363	86.00	1.50	-0.32
WAVE	11/09/2022 03:08	0.03	9.10	279	9.388	0.358	83.00	1.39	-0.43
WAVE	11/09/2022 03:18	0.05	10.70	55	9.272	0.335	91.00	1.27	-0.55
WAVE	11/09/2022 03:28	0.13	2.20	155	9.156	0.35	85.00	1.16	-0.66
WAVE	11/09/2022 03:38	0.11	2.10	279	9.041	0.336	88.00	1.04	-0.78
WAVE	11/09/2022 03:48	0.05	5.30	119	8.927	0.323	84.00	0.93	-0.89
WAVE	11/09/2022 03:58	0.08	4.00	99	8.829	0.295	84.00	0.83	-0.99
WAVE	11/09/2022 04:08	0.07	2.70	80	8.727	0.238	87.00	0.73	-1.09
WAVE	11/09/2022 04:18	0.05	10.70	83	8.632	0.225	91.00	0.63	-1.19
WAVE	11/09/2022 04:28	0.06	4.30	19	8.536	0.168	89.00	0.54	-1.28
WAVE	11/09/2022 04:38	0.07	2.10	131	8.456	0.08	89.00	0.46	-1.36
WAVE	11/09/2022 04:48	0.07	12.80	43	8.391	0.041	139.00	0.39	-1.43
WAVE	11/09/2022 04:58	0.06	3.40	359	8.327	0.011	173.00	0.33	-1.49
WAVE	11/09/2022 05:08	0.03	12.80	299	8.281	0.051	345.00	0.28	-1.54
WAVE	11/09/2022 05:18	0.04	16.00	3	8.238	0.083	284.00	0.24	-1.58
WAVE	11/09/2022 05:28	0.03	9.10	7	8.211	0.123	308.00	0.21	-1.61
WAVE	11/09/2022 05:38	0.06	2.60	227	8.206	0.159	329.00	0.21	-1.61
WAVE	11/09/2022 05:48	0.04	12.80	169	8.203	0.127	344.00	0.20	-1.62
WAVE	11/09/2022 05:58	0.02	9.10	107	8.215	0.116	344.00	0.22	-1.61
WAVE	11/09/2022 06:08	0.06	4.30	169	8.232	0.108	316.00	0.23	-1.59
WAVE	11/09/2022 06:18	0.07	3.00	99	8.27	0.123	264.00	0.27	-1.55
WAVE	11/09/2022 06:28	0.06	2.60	119	8.312	0.146	255.00	0.31	-1.51
WAVE	11/09/2022 06:38	0.06	12.80	31	8.366	0.188	261.00	0.37	-1.45
WAVE	11/09/2022 06:48	0.13	3.00	116	8.427	0.213	266.00	0.43	-1.39
WAVE	11/09/2022 06:58	0.16	2.70	117	8.485	0.191	268.00	0.48	-1.34
WAVE	11/09/2022 07:08	0.10	2.20	83	8.566	0.287	259.00	0.57	-1.25
WAVE	11/09/2022 07:18	0.03	10.70	271	8.647	0.294	262.00	0.65	-1.17
WAVE	11/09/2022 07:28	0.10	2.10	163	8.73	0.303	263.00	0.73	-1.09
WAVE	11/09/2022 07:38	0.08	2.40	223	8.816	0.323	261.00	0.82	-1.00
WAVE	11/09/2022 07:48	0.06	21.30	355	8.908	0.353	265.00	0.91	-0.91
WAVE	11/09/2022 07:58	0.09	2.40	95	9.001	0.344	260.00	1.00	-0.82
WAVE	11/09/2022 08:08	0.11	2.80	279	9.087	0.363	263.00	1.09	-0.73
WAVE	11/09/2022 08:18	0.05	3.60	87	9.186	0.393	257.00	1.19	-0.63
WAVE	11/09/2022 08:28	0.12	2.60	131	9.283	0.411	263.00	1.28	-0.54
WAVE	11/09/2022 08:38	0.19	2.40	309	9.384	0.464	263.00	1.38	-0.44
WAVE	11/09/2022 08:48	0.06	21.30	71	9.48	0.452	257.00	1.48	-0.34
WAVE	11/09/2022 08:58	0.24	2.70	91	9.578	0.461	260.00	1.58	-0.24
WAVE	11/09/2022 09:08	0.21	2.00	147	9.665	0.422	257.00	1.67	-0.16
WAVE	11/09/2022 09:18	0.05	16.00	163	9.762	0.445	257.00	1.76	-0.06
WAVE	11/09/2022 09:28	0.17	2.10	293	9.85	0.385	261.00	1.85	0.03
WAVE	11/09/2022 09:38	0.16	2.70	125	9.956	0.436	261.00	1.96	0.14
WAVE	11/09/2022 09:48	0.12	1.90	131	10.049	0.39	258.00	2.05	0.23
WAVE	11/09/2022 09:58	0.10	2.80	278	10.155	0.306	262.00	2.16	0.33
WAVE	11/09/2022 10:08	0.06	3.00	11	10.254	0.36	253.00	2.25	0.43
WAVE	11/09/2022 10:18	0.30	2.90	75	10.351	0.329	255.00	2.35	0.53
WAVE	11/09/2022 10:28	0.13	2.80	115	10.449	0.31	258.00	2.45	0.63
WAVE	11/09/2022 10:38	0.24	2.80	130	10.533	0.335	254.00	2.53	0.71
WAVE	11/09/2022 10:48	0.14	2.90	140	10.623	0.332	257.00	2.62	0.80
WAVE	11/09/2022 10:58	0.14	2.60	287	10.707	0.31	255.00	2.71	0.89
WAVE	11/09/2022 11:08	0.10	2.80	130	10.781	0.342	251.00	2.78	0.96
WAVE	11/09/2022 11:18	0.13	2.80	107	10.844	0.34	247.00	2.84	1.02
WAVE	11/09/2022 11:28	0.14	3.00	119	10.893	0.297	247.00	2.89	1.07
WAVE	11/09/2022 11:38	0.14	2.60	124	10.959	0.276	243.00	2.96	1.14
WAVE	11/09/2022 11:48	0.06	9.10	359	10.998	0.228	248.00	3.00	1.18
WAVE	11/09/2022 11:58	0.10	2.60	163	11.03	0.177	252.00	3.03	1.21
WAVE	11/09/2022 12:08	0.12	2.80	120	11.058	0.115	214.00	3.06	1.24
WAVE	11/09/2022 12:18	0.08	2.80	327	11.081	0.061	219.00	3.08	1.26

Name	Date Time	Significant Height(m)	Peak Time(sec)	Peak Direction (degree)	ADCP Depth(m)	Current Speed(m/s)	Current Direction (degree)	water level reference to CD	water level reference to 1.82 SHD
WAVE	11/09/2022 12:28	0.12	2.50	135	11.099	0.073	167.00	3.10	1.28
WAVE	11/09/2022 12:38	0.09	2.70	107	11.097	0.06	130.00	3.10	1.28
WAVE	11/09/2022 12:48	0.04	9.10	169	11.079	0.348	73.00	3.08	1.26
WAVE	11/09/2022 12:58	0.10	3.20	103	11.065	0.293	54.00	3.07	1.25
WAVE	11/09/2022 13:08	0.15	2.80	313	11.029	0.277	58.00	3.03	1.21
WAVE	11/09/2022 13:18	0.12	3.00	94	10.996	0.292	58.00	3.00	1.18
WAVE	11/09/2022 13:28	0.06	9.10	323	10.956	0.335	62.00	2.96	1.14
WAVE	11/09/2022 13:38	0.03	16.00	139	10.905	0.451	64.00	2.91	1.09
WAVE	11/09/2022 13:48	0.12	2.90	81	10.839	0.489	68.00	2.84	1.02
WAVE	11/09/2022 13:58	0.05	8.00	123	10.771	0.505	71.00	2.77	0.95
WAVE	11/09/2022 14:08	0.09	3.00	97	10.703	0.516	74.00	2.70	0.88
WAVE	11/09/2022 14:18	0.07	3.80	99	10.614	0.525	79.00	2.61	0.79
WAVE	11/09/2022 14:28	0.08	2.80	91	10.53	0.492	77.00	2.53	0.71
WAVE	11/09/2022 14:38	0.05	3.80	115	10.435	0.41	80.00	2.44	0.62
WAVE	11/09/2022 14:48	0.12	2.70	263	10.349	0.385	81.00	2.35	0.53
WAVE	11/09/2022 14:58	0.07	3.00	103	10.25	0.377	81.00	2.25	0.43
WAVE	11/09/2022 15:08	0.07	3.40	73	10.15	0.406	83.00	2.15	0.33
WAVE	11/09/2022 15:18	0.12	2.80	116	10.046	0.375	86.00	2.05	0.23
WAVE	11/09/2022 15:28	0.09	3.00	94	9.95	0.36	89.00	1.95	0.13
WAVE	11/09/2022 15:38	0.10	2.00	179	9.846	0.367	92.00	1.85	0.03
WAVE	11/09/2022 15:48	0.09	2.10	102	9.743	0.359	92.00	1.74	-0.08
WAVE	11/09/2022 15:58	0.10	3.60	107	9.643	0.354	94.00	1.64	-0.18
WAVE	11/09/2022 16:08	0.09	3.20	105	9.552	0.363	94.00	1.55	-0.27
WAVE	11/09/2022 16:18	0.07	3.00	95	9.461	0.316	93.00	1.46	-0.36
WAVE	11/09/2022 16:28	0.13	2.80	299	9.37	0.318	93.00	1.37	-0.45
WAVE	11/09/2022 16:38	0.17	2.90	98	9.277	0.31	94.00	1.28	-0.54
WAVE	11/09/2022 16:48	0.08	2.30	169	9.187	0.271	87.00	1.19	-0.63
WAVE	11/09/2022 16:58	0.13	2.20	135	9.115	0.291	79.00	1.12	-0.71
WAVE	11/09/2022 17:08	0.09	2.60	309	9.066	0.232	78.00	1.07	-0.75
WAVE	11/09/2022 17:18	0.12	2.80	283	9.01	0.219	78.00	1.01	-0.81
WAVE	11/09/2022 17:28	0.13	2.70	298	8.971	0.135	65.00	0.97	-0.85
WAVE	11/09/2022 17:38	0.14	2.90	293	8.951	0.057	53.00	0.95	-0.87
WAVE	11/09/2022 17:48	0.07	2.80	303	8.939	0.068	350.00	0.94	-0.88
WAVE	11/09/2022 17:58	0.07	4.00	139	8.934	0.098	285.00	0.93	-0.89
WAVE	11/09/2022 18:08	0.07	4.00	99	8.95	0.133	272.00	0.95	-0.87
WAVE	11/09/2022 18:18	0.13	2.70	93	8.966	0.16	302.00	0.97	-0.85
WAVE	11/09/2022 18:28	0.06	6.40	263	8.993	0.16	303.00	0.99	-0.83
WAVE	11/09/2022 18:38	0.06	3.60	139	9.033	0.168	291.00	1.03	-0.79
WAVE	11/09/2022 18:48	0.03	9.10	169	9.081	0.243	256.00	1.08	-0.74
WAVE	11/09/2022 18:58	0.11	2.60	91	9.13	0.276	256.00	1.13	-0.69
WAVE	11/09/2022 19:08	0.12	2.60	119	9.205	0.251	260.00	1.21	-0.62
WAVE	11/09/2022 19:18	0.09	2.70	291	9.265	0.276	263.00	1.27	-0.55
WAVE	11/09/2022 19:28	0.14	2.90	279	9.35	0.284	267.00	1.35	-0.47
WAVE	11/09/2022 19:38	0.11	2.50	50	9.414	0.295	264.00	1.41	-0.41
WAVE	11/09/2022 19:48	0.11	2.40	99	9.479	0.252	265.00	1.48	-0.34
WAVE	11/09/2022 19:58	0.07	2.80	119	9.558	0.278	263.00	1.56	-0.26
WAVE	11/09/2022 20:08	0.04	9.10	91	9.644	0.341	259.00	1.64	-0.18
WAVE	11/09/2022 20:18	0.09	2.90	299	9.706	0.348	260.00	1.71	-0.11
WAVE	11/09/2022 20:28	0.08	4.00	139	9.796	0.332	258.00	1.80	-0.02
WAVE	11/09/2022 20:38	0.09	1.90	83	9.873	0.319	259.00	1.87	0.05
WAVE	11/09/2022 20:48	0.05	9.10	151	9.963	0.315	263.00	1.96	0.14
WAVE	11/09/2022 20:58	0.06	5.30	169	10.055	0.382	263.00	2.06	0.24
WAVE	11/09/2022 21:08	0.06	3.00	87	10.142	0.368	256.00	2.14	0.32
WAVE	11/09/2022 21:18	0.05	21.30	203	10.24	0.385	253.00	2.24	0.42
WAVE	11/09/2022 21:28	0.06	2.90	181	10.341	0.447	254.00	2.34	0.52
WAVE	11/09/2022 21:38	0.04	9.10	169	10.452	0.435	257.00	2.45	0.63
WAVE	11/09/2022 21:48	0.05	12.80	169	10.546	0.448	258.00	2.55	0.73
WAVE	11/09/2022 21:58	0.05	10.70	169	10.638	0.402	257.00	2.64	0.82
WAVE	11/09/2022 22:08	0.03	9.10	143	10.729	0.35	258.00	2.73	0.91
WAVE	11/09/2022 22:18	0.07	2.10	195	10.81	0.386	256.00	2.81	0.99
WAVE	11/09/2022 22:28	0.08	2.50	31	10.896	0.328	252.00	2.90	1.08
WAVE	11/09/2022 22:38	0.07	10.70	343	10.975	0.316	253.00	2.98	1.16
WAVE	11/09/2022 22:48	0.07	3.20	207	11.051	0.312	252.00	3.05	1.23
WAVE	11/09/2022 22:58	0.11	2.10	115	11.127	0.268	254.00	3.13	1.31

Name	Date Time	Significant Height(m)	Peak Time(sec)	Peak Direction (degree)	ADCP Depth(m)	Current Speed(m/s)	Current Direction (degree)	water level reference to CD	water level reference to 1.82 SHD
WAVE	11/09/2022 23:08	0.05	8.00	169	11.192	0.238	261.00	3.19	1.37
WAVE	11/09/2022 23:18	0.07	16.00	91	11.244	0.23	252.00	3.24	1.42
WAVE	11/09/2022 23:28	0.10	2.30	139	11.285	0.209	239.00	3.29	1.47
WAVE	11/09/2022 23:38	0.06	3.40	169	11.321	0.163	234.00	3.32	1.50
WAVE	11/09/2022 23:48	0.07	9.10	155	11.346	0.1	246.00	3.35	1.53
WAVE	11/09/2022 23:58	0.05	9.10	75	11.354	0.073	232.00	3.35	1.53
WAVE	12/09/2022 00:08	0.05	9.10	263	11.353	0.061	187.00	3.35	1.53
WAVE	12/09/2022 00:18	0.03	10.70	247	11.344	0.139	133.00	3.34	1.52
WAVE	12/09/2022 00:28	0.05	9.10	63	11.327	0.139	118.00	3.33	1.51
WAVE	12/09/2022 00:38	0.06	10.70	169	11.303	0.172	98.00	3.30	1.48
WAVE	12/09/2022 00:48	0.06	3.60	91	11.253	0.234	82.00	3.25	1.43
WAVE	12/09/2022 00:58	0.03	16.00	169	11.209	0.376	63.00	3.21	1.39
WAVE	12/09/2022 01:08	0.05	9.10	59	11.137	0.39	65.00	3.14	1.32
WAVE	12/09/2022 01:18	0.07	2.70	163	11.071	0.431	65.00	3.07	1.25
WAVE	12/09/2022 01:28	0.09	1.90	159	10.994	0.429	68.00	2.99	1.17
WAVE	12/09/2022 01:38	0.03	10.70	275	10.914	0.46	74.00	2.91	1.09
WAVE	12/09/2022 01:48	0.07	3.80	91	10.837	0.499	75.00	2.84	1.02
WAVE	12/09/2022 01:58	0.15	2.40	281	10.753	0.517	81.00	2.75	0.93
WAVE	12/09/2022 02:08	0.02	9.10	115	10.652	0.432	78.00	2.65	0.83
WAVE	12/09/2022 02:18	0.03	9.10	151	10.56	0.438	82.00	2.56	0.74
WAVE	12/09/2022 02:28	0.05	16.00	151	10.462	0.397	83.00	2.46	0.64
WAVE	12/09/2022 02:38	0.06	21.30	283	10.347	0.397	88.00	2.35	0.53
WAVE	12/09/2022 02:48	0.03	16.00	169	10.235	0.427	88.00	2.24	0.41
WAVE	12/09/2022 02:58	0.09	21.30	79	10.12	0.41	89.00	2.12	0.30
WAVE	12/09/2022 03:08	0.06	2.70	283	10.004	0.39	91.00	2.00	0.18
WAVE	12/09/2022 03:18	0.05	5.30	167	9.881	0.394	92.00	1.88	0.06
WAVE	12/09/2022 03:28	0.05	3.20	109	9.761	0.387	94.00	1.76	-0.06
WAVE	12/09/2022 03:38	0.04	9.10	299	9.646	0.357	94.00	1.65	-0.17
WAVE	12/09/2022 03:48	0.09	2.10	23	9.548	0.377	91.00	1.55	-0.27
WAVE	12/09/2022 03:58	0.05	16.00	67	9.435	0.369	90.00	1.44	-0.39
WAVE	12/09/2022 04:08	0.11	2.00	31	9.318	0.408	86.00	1.32	-0.50
WAVE	12/09/2022 04:18	0.02	16.00	47	9.217	0.39	86.00	1.22	-0.60
WAVE	12/09/2022 04:28	0.05	12.80	115	9.096	0.38	83.00	1.10	-0.72
WAVE	12/09/2022 04:38	0.03	12.80	83	8.993	0.339	86.00	0.99	-0.83
WAVE	12/09/2022 04:48	0.04	21.30	169	8.893	0.294	86.00	0.89	-0.93
WAVE	12/09/2022 04:58	0.02	21.30	55	8.799	0.256	91.00	0.80	-1.02
WAVE	12/09/2022 05:08	0.02	12.80	235	8.708	0.232	93.00	0.71	-1.11
WAVE	12/09/2022 05:18	0.03	21.30	75	8.622	0.165	87.00	0.62	-1.20
WAVE	12/09/2022 05:28	0.04	16.00	123	8.549	0.144	77.00	0.55	-1.27
WAVE	12/09/2022 05:38	0.05	10.70	67	8.477	0.098	73.00	0.48	-1.34
WAVE	12/09/2022 05:48	0.07	12.80	307	8.429	0.066	75.00	0.43	-1.39
WAVE	12/09/2022 05:58	0.05	4.60	291	8.382	0.033	18.00	0.38	-1.44
WAVE	12/09/2022 06:08	0.03	9.10	169	8.351	0.109	352.00	0.35	-1.47
WAVE	12/09/2022 06:18	0.04	12.80	51	8.324	0.12	5.00	0.32	-1.50
WAVE	12/09/2022 06:28	0.12	3.40	102	8.314	0.209	358.00	0.31	-1.51
WAVE	12/09/2022 06:38	0.03	16.00	169	8.326	0.158	341.00	0.33	-1.49
WAVE	12/09/2022 06:48	0.10	2.70	239	8.349	0.152	343.00	0.35	-1.47
WAVE	12/09/2022 06:58	0.05	3.60	155	8.38	0.138	330.00	0.38	-1.44
WAVE	12/09/2022 07:08	0.06	9.10	111	8.421	0.13	283.00	0.42	-1.40
WAVE	12/09/2022 07:18	0.04	10.70	243	8.479	0.182	265.00	0.48	-1.34
WAVE	12/09/2022 07:28	0.09	3.80	243	8.538	0.278	262.00	0.54	-1.28
WAVE	12/09/2022 07:38	0.06	2.70	123	8.596	0.228	266.00	0.60	-1.22
WAVE	12/09/2022 07:48	0.07	3.20	207	8.67	0.268	262.00	0.67	-1.15
WAVE	12/09/2022 07:58	0.11	2.00	263	8.754	0.297	263.00	0.75	-1.07
WAVE	12/09/2022 08:08	0.20	2.30	150	8.843	0.353	266.00	0.84	-0.98
WAVE	12/09/2022 08:18	0.06	10.70	11	8.943	0.353	266.00	0.94	-0.88
WAVE	12/09/2022 08:28	0.10	2.60	119	9.036	0.42	259.00	1.04	-0.78
WAVE	12/09/2022 08:38	0.07	2.60	359	9.145	0.401	266.00	1.15	-0.68
WAVE	12/09/2022 08:48	0.09	2.60	149	9.242	0.413	263.00	1.24	-0.58
WAVE	12/09/2022 08:58	0.03	12.80	343	9.334	0.435	265.00	1.33	-0.49
WAVE	12/09/2022 09:08	0.07	2.50	11	9.422	0.48	266.00	1.42	-0.40
WAVE	12/09/2022 09:18	0.07	2.60	151	9.516	0.488	263.00	1.52	-0.30
WAVE	12/09/2022 09:28	0.06	2.70	63	9.608	0.462	260.00	1.61	-0.21
WAVE	12/09/2022 09:38	0.06	2.60	103	9.694	0.452	259.00	1.69	-0.13

Name	Date Time	Significant Height(m)	Peak Time(sec)	Peak Direction (degree)	ADCP Depth(m)	Current Speed(m/s)	Current Direction (degree)	water level reference to CD	water level reference to 1.82 SHD
WAVE	12/09/2022 09:48	0.11	2.60	120	9.783	0.408	259.00	1.78	-0.04
WAVE	12/09/2022 09:58	0.09	2.60	27	9.876	0.392	260.00	1.88	0.06
WAVE	12/09/2022 10:08	0.08	2.50	79	9.97	0.303	257.00	1.97	0.15
WAVE	12/09/2022 10:18	0.05	21.30	169	10.061	0.324	262.00	2.06	0.24
WAVE	12/09/2022 10:28	0.04	10.70	263	10.149	0.312	258.00	2.15	0.33
WAVE	12/09/2022 10:38	0.06	3.00	339	10.252	0.348	257.00	2.25	0.43
WAVE	12/09/2022 10:48	0.08	2.50	169	10.353	0.321	257.00	2.35	0.53
WAVE	12/09/2022 10:58	0.06	3.40	279	10.451	0.305	255.00	2.45	0.63
WAVE	12/09/2022 11:08	0.09	2.30	315	10.551	0.328	255.00	2.55	0.73
WAVE	12/09/2022 11:18	0.11	2.80	161	10.632	0.371	257.00	2.63	0.81
WAVE	12/09/2022 11:28	0.06	2.50	217	10.708	0.357	260.00	2.71	0.89
WAVE	12/09/2022 11:38	0.12	2.40	299	10.779	0.352	255.00	2.78	0.96
WAVE	12/09/2022 11:48	0.06	3.40	59	10.849	0.346	252.00	2.85	1.03
WAVE	12/09/2022 11:58	0.04	9.10	169	10.903	0.315	245.00	2.90	1.08
WAVE	12/09/2022 12:08	0.06	4.30	110	10.943	0.277	244.00	2.94	1.12
WAVE	12/09/2022 12:18	0.08	3.00	275	10.993	0.229	245.00	2.99	1.17
WAVE	12/09/2022 12:28	0.09	2.90	304	11.031	0.188	245.00	3.03	1.21
WAVE	12/09/2022 12:38	0.05	16.00	83	11.05	0.068	237.00	3.05	1.23
WAVE	12/09/2022 12:48	0.10	2.70	123	11.062	0.056	208.00	3.06	1.24
WAVE	12/09/2022 12:58	0.02	16.00	295	11.063	0.093	152.00	3.06	1.24
WAVE	12/09/2022 13:08	0.07	9.10	331	11.054	0.173	120.00	3.05	1.23
WAVE	12/09/2022 13:18	0.14	2.20	261	11.025	0.283	57.00	3.03	1.21
WAVE	12/09/2022 13:28	0.04	9.10	91	10.994	0.33	60.00	2.99	1.17
WAVE	12/09/2022 13:38	0.06	3.80	103	10.946	0.385	57.00	2.95	1.13
WAVE	12/09/2022 13:48	0.07	3.40	73	10.895	0.424	61.00	2.90	1.08
WAVE	12/09/2022 13:58	0.04	8.00	167	10.837	0.47	64.00	2.84	1.02
WAVE	12/09/2022 14:08	0.08	4.60	87	10.776	0.489	65.00	2.78	0.96
WAVE	12/09/2022 14:18	0.06	3.20	95	10.708	0.516	66.00	2.71	0.89
WAVE	12/09/2022 14:28	0.03	8.00	169	10.642	0.519	70.00	2.64	0.82
WAVE	12/09/2022 14:38	0.06	4.00	99	10.574	0.504	72.00	2.57	0.75
WAVE	12/09/2022 14:48	0.10	3.40	93	10.497	0.442	73.00	2.50	0.68
WAVE	12/09/2022 14:58	0.14	2.90	83	10.415	0.32	84.00	2.42	0.59
WAVE	12/09/2022 15:08	0.08	2.10	83	10.324	0.314	90.00	2.32	0.50
WAVE	12/09/2022 15:18	0.19	3.20	89	10.229	0.294	93.00	2.23	0.41
WAVE	12/09/2022 15:28	0.07	3.80	111	10.137	0.319	99.00	2.14	0.32
WAVE	12/09/2022 15:38	0.10	4.00	95	10.04	0.327	96.00	2.04	0.22
WAVE	12/09/2022 15:48	0.04	4.60	115	9.938	0.313	94.00	1.94	0.12
WAVE	12/09/2022 15:58	0.12	2.10	79	9.832	0.33	97.00	1.83	0.01
WAVE	12/09/2022 16:08	0.07	3.40	95	9.723	0.355	89.00	1.72	-0.10
WAVE	12/09/2022 16:18	0.08	10.70	247	9.62	0.398	85.00	1.62	-0.20
WAVE	12/09/2022 16:28	0.10	2.70	75	9.529	0.413	83.00	1.53	-0.29
WAVE	12/09/2022 16:38	0.19	2.70	285	9.432	0.382	85.00	1.43	-0.39
WAVE	12/09/2022 16:48	0.06	3.60	103	9.336	0.368	87.00	1.34	-0.48
WAVE	12/09/2022 17:12	0.19	10.70	159	9.122	0.292	82.00	1.12	-0.70
WAVE	12/09/2022 17:22	0.10	2.10	169	9.042	0.273	83.00	1.04	-0.78
WAVE	12/09/2022 17:32	0.11	3.20	108	8.975	0.21	85.00	0.98	-0.85
WAVE	12/09/2022 17:42	0.05	21.30	231	8.919	0.184	83.00	0.92	-0.90
WAVE	12/09/2022 17:52	0.08	4.60	95	8.867	0.112	73.00	0.87	-0.95
WAVE	12/09/2022 18:02	0.32	2.90	288	8.833	0.043	80.00	0.83	-0.99
WAVE	12/09/2022 18:12	0.06	2.90	95	8.819	0.069	312.00	0.82	-1.00
WAVE	12/09/2022 18:22	0.12	2.60	111	8.816	0.123	337.00	0.82	-1.00
WAVE	12/09/2022 18:32	0.09	2.10	119	8.802	0.186	1.00	0.80	-1.02
WAVE	12/09/2022 18:42	0.18	2.10	171	8.82	0.178	351.00	0.82	-1.00
WAVE	12/09/2022 18:52	0.07	2.90	319	8.845	0.133	336.00	0.85	-0.97
WAVE	12/09/2022 19:02	0.03	9.10	67	8.866	0.109	290.00	0.87	-0.95
WAVE	12/09/2022 19:12	0.11	3.20	213	8.903	0.158	262.00	0.90	-0.92
WAVE	12/09/2022 19:22	0.04	9.10	327	8.949	0.176	260.00	0.95	-0.87
WAVE	12/09/2022 19:32	0.03	21.30	123	8.992	0.205	252.00	0.99	-0.83
WAVE	12/09/2022 19:42	0.10	2.50	83	9.055	0.138	270.00	1.06	-0.77
WAVE	12/09/2022 19:52	0.03	9.10	119	9.121	0.14	239.00	1.12	-0.70
WAVE	12/09/2022 20:02	0.05	5.80	63	9.193	0.192	257.00	1.19	-0.63
WAVE	12/09/2022 20:12	0.03	16.00	63	9.267	0.197	263.00	1.27	-0.55
WAVE	12/09/2022 20:22	0.06	8.00	155	9.328	0.187	267.00	1.33	-0.49
WAVE	12/09/2022 20:32	0.05	2.50	167	9.403	0.175	261.00	1.40	-0.42

Name	Date Time	Significant Height(m)	Peak Time(sec)	Peak Direction (degree)	ADCP Depth(m)	Current Speed(m/s)	Current Direction (degree)	water level reference to CD	water level reference to 1.82 SHD
WAVE	12/09/2022 20:42	0.06	2.60	169	9.48	0.194	256.00	1.48	-0.34
WAVE	12/09/2022 20:52	0.06	10.70	311	9.559	0.253	264.00	1.56	-0.26
WAVE	12/09/2022 21:02	0.05	2.80	95	9.64	0.273	277.00	1.64	-0.18
WAVE	12/09/2022 21:12	0.04	5.80	19	9.714	0.316	267.00	1.71	-0.11
WAVE	12/09/2022 21:22	0.05	3.80	97	9.803	0.297	255.00	1.80	-0.02
WAVE	12/09/2022 21:32	0.07	2.30	307	9.884	0.339	262.00	1.88	0.06
WAVE	12/09/2022 21:42	0.06	3.20	271	9.978	0.338	263.00	1.98	0.16
WAVE	12/09/2022 21:52	0.04	6.40	195	10.074	0.406	259.00	2.07	0.25
WAVE	12/09/2022 22:02	0.04	9.10	19	10.166	0.379	259.00	2.17	0.35
WAVE	12/09/2022 22:12	0.04	10.70	27	10.262	0.362	255.00	2.26	0.44
WAVE	12/09/2022 22:22	0.07	9.10	351	10.378	0.399	253.00	2.38	0.56
WAVE	12/09/2022 22:32	0.04	12.80	23	10.494	0.425	258.00	2.49	0.67
WAVE	12/09/2022 22:42	0.06	12.80	169	10.593	0.425	260.00	2.59	0.77
WAVE	12/09/2022 22:52	0.07	9.10	167	10.697	0.405	256.00	2.70	0.88
WAVE	12/09/2022 23:02	0.05	4.90	279	10.789	0.391	255.00	2.79	0.97
WAVE	12/09/2022 23:12	0.09	3.40	279	10.886	0.403	257.00	2.89	1.07
WAVE	12/09/2022 23:22	0.04	9.10	215	10.978	0.398	254.00	2.98	1.16
WAVE	12/09/2022 23:32	0.06	2.80	71	11.042	0.364	255.00	3.04	1.22
WAVE	12/09/2022 23:42	0.03	9.10	215	11.122	0.335	251.00	3.12	1.30
WAVE	12/09/2022 23:52	0.07	3.00	119	11.195	0.333	250.00	3.20	1.38
WAVE	13/09/2022 00:02	0.14	3.40	106	11.264	0.254	251.00	3.26	1.44
WAVE	13/09/2022 00:12	0.05	3.40	147	11.302	0.192	253.00	3.30	1.48
WAVE	13/09/2022 00:22	0.09	2.90	252	11.346	0.189	247.00	3.35	1.53
WAVE	13/09/2022 00:32	0.07	9.10	271	11.373	0.157	247.00	3.37	1.55
WAVE	13/09/2022 00:42	0.13	2.00	119	11.391	0.077	215.00	3.39	1.57
WAVE	13/09/2022 00:52	0.08	2.30	169	11.392	0.075	152.00	3.39	1.57
WAVE	13/09/2022 01:02	0.03	9.10	291	11.381	0.091	137.00	3.38	1.56
WAVE	13/09/2022 01:12	0.06	3.00	107	11.358	0.105	131.00	3.36	1.54
WAVE	13/09/2022 01:22	0.04	12.80	169	11.333	0.158	104.00	3.33	1.51
WAVE	13/09/2022 01:32	0.03	10.70	315	11.297	0.22	86.00	3.30	1.48
WAVE	13/09/2022 01:42	0.05	9.10	311	11.246	0.376	65.00	3.25	1.43
WAVE	13/09/2022 01:52	0.06	5.30	99	11.174	0.367	65.00	3.17	1.35
WAVE	13/09/2022 02:02	0.05	16.00	99	11.114	0.447	66.00	3.11	1.29
WAVE	13/09/2022 02:12	0.04	3.40	227	11.031	0.433	63.00	3.03	1.21
WAVE	13/09/2022 02:22	0.03	9.10	275	10.95	0.497	69.00	2.95	1.13
WAVE	13/09/2022 02:32	0.04	16.00	19	10.87	0.547	73.00	2.87	1.05
WAVE	13/09/2022 02:42	0.04	10.70	135	10.799	0.47	72.00	2.80	0.98
WAVE	13/09/2022 02:52	0.07	9.10	169	10.71	0.441	73.00	2.71	0.89
WAVE	13/09/2022 03:02	0.03	21.30	295	10.608	0.404	76.00	2.61	0.79
WAVE	13/09/2022 03:12	0.06	2.60	323	10.51	0.433	84.00	2.51	0.69
WAVE	13/09/2022 03:22	0.04	10.70	235	10.406	0.408	88.00	2.41	0.59
WAVE	13/09/2022 03:32	0.08	2.50	263	10.294	0.403	94.00	2.29	0.47
WAVE	13/09/2022 03:42	0.07	2.40	163	10.197	0.395	99.00	2.20	0.38
WAVE	13/09/2022 03:52	0.03	10.70	327	10.059	0.352	99.00	2.06	0.24
WAVE	13/09/2022 04:02	0.03	16.00	35	9.965	0.371	97.00	1.97	0.15
WAVE	13/09/2022 04:12	0.07	10.70	127	9.858	0.354	94.00	1.86	0.04
WAVE	13/09/2022 04:22	0.05	12.80	335	9.737	0.367	89.00	1.74	-0.08
WAVE	13/09/2022 04:32	0.06	9.10	169	9.631	0.358	89.00	1.63	-0.19
WAVE	13/09/2022 04:42	0.05	9.10	43	9.534	0.331	89.00	1.53	-0.29
WAVE	13/09/2022 04:52	0.05	12.80	171	9.416	0.328	87.00	1.42	-0.40
WAVE	13/09/2022 05:02	0.05	6.40	283	9.318	0.296	90.00	1.32	-0.50
WAVE	13/09/2022 05:12	0.06	9.10	115	9.218	0.279	82.00	1.22	-0.60
WAVE	13/09/2022 05:22	0.07	2.60	231	9.113	0.25	77.00	1.11	-0.71
WAVE	13/09/2022 05:32	0.05	21.30	55	9.026	0.184	75.00	1.03	-0.79
WAVE	13/09/2022 05:42	0.13	2.20	188	8.958	0.167	82.00	0.96	-0.86
WAVE	13/09/2022 05:52	0.06	12.80	339	8.875	0.135	86.00	0.88	-0.95
WAVE	13/09/2022 06:02	0.07	3.80	215	8.803	0.089	62.00	0.80	-1.02
WAVE	13/09/2022 06:12	0.04	9.10	99	8.752	0.081	51.00	0.75	-1.07
WAVE	13/09/2022 06:22	0.04	9.10	311	8.691	0.125	22.00	0.69	-1.13
WAVE	13/09/2022 06:32	0.06	21.30	87	8.661	0.119	27.00	0.66	-1.16
WAVE	13/09/2022 06:42	0.04	16.00	163	8.634	0.097	39.00	0.63	-1.19
WAVE	13/09/2022 06:52	0.02	12.80	311	8.619	0.147	347.00	0.62	-1.20
WAVE	13/09/2022 07:02	0.02	21.30	247	8.609	0.224	12.00	0.61	-1.21
WAVE	13/09/2022 07:12	0.03	12.80	331	8.623	0.175	7.00	0.62	-1.20

Name	Date Time	Significant Height(m)	Peak Time(sec)	Peak Direction (degree)	ADCP Depth(m)	Current Speed(m/s)	Current Direction (degree)	water level reference to CD	water level reference to 1.82 SHD
WAVE	13/09/2022 07:22	0.09	2.50	91	8.627	0.076	337.00	0.63	-1.19
WAVE	13/09/2022 07:32	0.05	2.20	27	8.654	0.091	311.00	0.65	-1.17
WAVE	13/09/2022 07:42	0.14	2.60	103	8.684	0.082	308.00	0.68	-1.14
WAVE	13/09/2022 07:52	0.05	12.80	299	8.726	0.114	278.00	0.73	-1.09
WAVE	13/09/2022 08:02	0.08	2.70	119	8.778	0.135	264.00	0.78	-1.04
WAVE	13/09/2022 08:12	0.05	4.30	169	8.832	0.173	251.00	0.83	-0.99
WAVE	13/09/2022 08:22	0.06	3.20	103	8.895	0.146	277.00	0.90	-0.93
WAVE	13/09/2022 08:32	0.20	2.50	240	8.955	0.22	251.00	0.96	-0.87
WAVE	13/09/2022 08:42	0.04	12.80	135	9.035	0.256	259.00	1.04	-0.79
WAVE	13/09/2022 08:52	0.06	9.10	169	9.121	0.224	265.00	1.12	-0.70
WAVE	13/09/2022 09:02	0.10	2.80	250	9.196	0.239	261.00	1.20	-0.62
WAVE	13/09/2022 09:12	0.09	2.90	277	9.278	0.338	263.00	1.28	-0.54
WAVE	13/09/2022 09:22	0.04	12.80	67	9.361	0.377	272.00	1.36	-0.46
WAVE	13/09/2022 09:32	0.15	2.80	135	9.449	0.443	264.00	1.45	-0.37
WAVE	13/09/2022 09:42	0.12	3.20	134	9.524	0.399	263.00	1.52	-0.30
WAVE	13/09/2022 09:52	0.08	3.00	223	9.622	0.358	259.00	1.62	-0.20
WAVE	13/09/2022 10:02	0.07	3.00	139	9.717	0.359	258.00	1.72	-0.10
WAVE	13/09/2022 10:12	0.28	2.60	120	9.801	0.276	260.00	1.80	-0.02
WAVE	13/09/2022 10:22	0.08	2.60	297	9.892	0.355	258.00	1.89	0.07
WAVE	13/09/2022 10:32	0.10	2.10	109	9.972	0.363	256.00	1.97	0.15
WAVE	13/09/2022 10:42	0.05	4.30	219	10.084	0.364	261.00	2.08	0.26
WAVE	13/09/2022 10:52	0.05	9.10	223	10.17	0.357	259.00	2.17	0.35
WAVE	13/09/2022 11:02	0.10	2.80	119	10.272	0.354	259.00	2.27	0.45
WAVE	13/09/2022 11:12	0.05	9.10	239	10.378	0.31	258.00	2.38	0.56
WAVE	13/09/2022 11:22	0.04	4.60	85	10.484	0.362	254.00	2.48	0.66
WAVE	13/09/2022 11:32	0.14	2.60	129	10.578	0.365	256.00	2.58	0.76
WAVE	13/09/2022 11:42	0.12	3.60	226	10.66	0.369	258.00	2.66	0.84
WAVE	13/09/2022 11:52	0.10	2.50	115	10.754	0.384	259.00	2.75	0.93
WAVE	13/09/2022 12:02	0.05	2.90	171	10.834	0.335	255.00	2.83	1.01
WAVE	13/09/2022 12:12	0.14	2.90	121	10.905	0.339	253.00	2.91	1.09
WAVE	13/09/2022 12:22	0.12	2.00	275	10.965	0.314	253.00	2.97	1.15
WAVE	13/09/2022 12:32	0.08	2.80	247	11.01	0.295	246.00	3.01	1.19
WAVE	13/09/2022 12:42	0.08	12.80	15	11.059	0.241	252.00	3.06	1.24
WAVE	13/09/2022 12:52	0.08	2.50	119	11.096	0.205	247.00	3.10	1.28
WAVE	13/09/2022 13:02	0.15	2.70	310	11.102	0.115	240.00	3.10	1.28
WAVE	13/09/2022 13:12	0.06	4.60	115	11.128	0.106	243.00	3.13	1.31
WAVE	13/09/2022 13:22	0.13	2.60	293	11.124	0.074	164.00	3.12	1.30
WAVE	13/09/2022 13:32	0.06	12.80	247	11.111	0.15	116.00	3.11	1.29
WAVE	13/09/2022 13:42	0.14	2.90	109	11.093	0.237	92.00	3.09	1.27
WAVE	13/09/2022 13:52	0.06	21.30	119	11.051	0.285	91.00	3.05	1.23
WAVE	13/09/2022 14:02	0.06	4.00	79	11.001	0.392	71.00	3.00	1.18
WAVE	13/09/2022 14:12	0.06	3.60	59	10.952	0.483	59.00	2.95	1.13
WAVE	13/09/2022 14:22	0.07	2.90	197	10.889	0.494	63.00	2.89	1.07
WAVE	13/09/2022 14:32	0.22	2.20	138	10.828	0.475	67.00	2.83	1.01
WAVE	13/09/2022 14:42	0.07	3.40	91	10.761	0.425	68.00	2.76	0.94
WAVE	13/09/2022 14:52	0.12	2.90	99	10.696	0.445	74.00	2.70	0.88
WAVE	13/09/2022 15:02	0.08	2.80	49	10.623	0.493	65.00	2.62	0.80
WAVE	13/09/2022 15:12	0.08	3.00	101	10.549	0.469	71.00	2.55	0.73
WAVE	13/09/2022 15:22	0.08	2.10	51	10.456	0.458	76.00	2.46	0.64
WAVE	13/09/2022 15:32	0.06	2.90	111	10.357	0.375	79.00	2.36	0.54
WAVE	13/09/2022 15:42	0.08	9.10	291	10.267	0.344	89.00	2.27	0.45
WAVE	13/09/2022 15:52	0.07	3.40	87	10.164	0.355	101.00	2.16	0.34
WAVE	13/09/2022 16:02	0.06	3.80	87	10.065	0.338	101.00	2.07	0.24
WAVE	13/09/2022 16:12	0.17	1.80	108	9.966	0.356	98.00	1.97	0.15
WAVE	13/09/2022 16:22	0.13	3.00	84	9.862	0.371	95.00	1.86	0.04
WAVE	13/09/2022 16:32	0.14	2.50	130	9.763	0.39	89.00	1.76	-0.06
WAVE	13/09/2022 16:42	0.08	3.00	95	9.652	0.373	89.00	1.65	-0.17
WAVE	13/09/2022 16:52	0.06	2.60	73	9.546	0.356	91.00	1.55	-0.27
WAVE	13/09/2022 17:02	0.15	2.70	301	9.429	0.35	91.00	1.43	-0.39
WAVE	13/09/2022 17:12	0.06	2.70	275	9.325	0.346	91.00	1.33	-0.50
WAVE	13/09/2022 17:22	0.07	2.10	91	9.219	0.363	88.00	1.22	-0.60
WAVE	13/09/2022 17:32	0.06	3.00	111	9.126	0.297	90.00	1.13	-0.69
WAVE	13/09/2022 17:42	0.06	8.00	169	9.039	0.269	92.00	1.04	-0.78
WAVE	13/09/2022 17:52	0.33	2.70	285	8.95	0.203	104.00	0.95	-0.87

Name	Date Time	Significant Height(m)	Peak Time(sec)	Peak Direction (degree)	ADCP Depth(m)	Current Speed(m/s)	Current Direction (degree)	water level reference to CD	water level reference to 1.82 SHD
WAVE	13/09/2022 18:02	0.38	2.70	292	8.863	0.192	85.00	0.86	-0.96
WAVE	13/09/2022 18:12	0.10	3.80	81	8.798	0.153	74.00	0.80	-1.02
WAVE	13/09/2022 18:22	0.11	2.70	95	8.739	0.082	66.00	0.74	-1.08
WAVE	13/09/2022 18:32	0.10	2.40	103	8.692	0.135	21.00	0.69	-1.13
WAVE	13/09/2022 18:42	0.13	2.80	121	8.655	0.088	13.00	0.65	-1.17
WAVE	13/09/2022 18:52	0.13	2.50	76	8.635	0.051	319.00	0.64	-1.19
WAVE	13/09/2022 19:02	0.07	2.90	91	8.624	0.086	242.00	0.62	-1.20
WAVE	13/09/2022 19:12	0.12	2.90	94	8.619	0.074	276.00	0.62	-1.20
WAVE	13/09/2022 19:22	0.07	2.70	95	8.619	0.131	327.00	0.62	-1.20
WAVE	13/09/2022 19:32	0.03	12.80	339	8.622	0.127	339.00	0.62	-1.20
WAVE	13/09/2022 19:42	0.10	2.80	92	8.645	0.097	328.00	0.65	-1.18
WAVE	13/09/2022 19:52	0.14	2.60	173	8.679	0.146	272.00	0.68	-1.14
WAVE	13/09/2022 20:02	0.11	2.30	322	8.722	0.097	277.00	0.72	-1.10
WAVE	13/09/2022 20:12	0.07	10.70	67	8.773	0.162	257.00	0.77	-1.05
WAVE	13/09/2022 20:22	0.10	2.70	253	8.829	0.146	262.00	0.83	-0.99
WAVE	13/09/2022 20:32	0.06	16.00	263	8.888	0.136	264.00	0.89	-0.93
WAVE	13/09/2022 20:42	0.09	2.40	99	8.951	0.152	287.00	0.95	-0.87
WAVE	13/09/2022 20:52	0.05	3.80	71	9.016	0.156	264.00	1.02	-0.80
WAVE	13/09/2022 21:02	0.08	9.10	335	9.088	0.177	272.00	1.09	-0.73
WAVE	13/09/2022 21:12	0.10	2.10	169	9.174	0.236	262.00	1.17	-0.65
WAVE	13/09/2022 21:22	0.07	2.20	47	9.259	0.283	259.00	1.26	-0.56
WAVE	13/09/2022 21:32	0.02	9.10	343	9.356	0.33	259.00	1.36	-0.46
WAVE	13/09/2022 21:42	0.05	2.70	103	9.444	0.367	263.00	1.44	-0.38
WAVE	13/09/2022 21:52	0.16	2.60	124	9.525	0.404	261.00	1.53	-0.30
WAVE	13/09/2022 22:02	0.03	10.70	237	9.606	0.429	263.00	1.61	-0.21
WAVE	13/09/2022 22:12	0.02	9.10	169	9.691	0.378	257.00	1.69	-0.13
WAVE	13/09/2022 22:22	0.06	9.10	169	9.783	0.361	258.00	1.78	-0.04
WAVE	13/09/2022 22:32	0.05	10.70	169	9.884	0.359	256.00	1.88	0.06
WAVE	13/09/2022 22:42	0.05	8.00	111	9.993	0.352	254.00	1.99	0.17
WAVE	13/09/2022 22:52	0.12	2.90	259	10.099	0.322	252.00	2.10	0.28
WAVE	13/09/2022 23:02	0.07	12.80	331	10.199	0.398	255.00	2.20	0.38
WAVE	13/09/2022 23:12	0.04	16.00	219	10.298	0.387	258.00	2.30	0.48
WAVE	13/09/2022 23:22	0.06	16.00	31	10.398	0.293	256.00	2.40	0.58
WAVE	13/09/2022 23:32	0.08	2.80	239	10.489	0.31	252.00	2.49	0.67
WAVE	13/09/2022 23:42	0.05	5.80	169	10.569	0.293	250.00	2.57	0.75
WAVE	13/09/2022 23:52	0.03	21.30	103	10.655	0.301	252.00	2.66	0.83
WAVE	14/09/2022 00:02	0.06	12.80	55	10.74	0.291	253.00	2.74	0.92
WAVE	14/09/2022 00:12	0.06	16.00	259	10.816	0.277	249.00	2.82	1.00
WAVE	14/09/2022 00:22	0.05	12.80	169	10.879	0.249	256.00	2.88	1.06
WAVE	14/09/2022 00:32	0.04	9.10	111	10.942	0.227	245.00	2.94	1.12
WAVE	14/09/2022 00:52	0.05	12.80	169	11.046	0.199	240.00	3.05	1.23
WAVE	14/09/2022 01:02	0.05	21.30	83	11.086	0.18	227.00	3.09	1.27
WAVE	14/09/2022 01:12	0.05	9.10	169	11.111	0.149	212.00	3.11	1.29
WAVE	14/09/2022 01:22	0.03	10.70	107	11.133	0.118	212.00	3.13	1.31
WAVE	14/09/2022 01:32	0.08	12.80	271	11.149	0.075	198.00	3.15	1.33
WAVE	14/09/2022 01:42	0.05	10.70	169	11.147	0.141	140.00	3.15	1.33
WAVE	14/09/2022 01:52	0.07	2.60	103	11.143	0.108	115.00	3.14	1.32
WAVE	14/09/2022 02:02	0.04	16.00	39	11.121	0.322	75.00	3.12	1.30
WAVE	14/09/2022 02:12	0.04	9.10	169	11.098	0.265	57.00	3.10	1.28
WAVE	14/09/2022 02:22	0.06	3.80	111	11.06	0.276	57.00	3.06	1.24
WAVE	14/09/2022 02:32	0.04	21.30	123	11.02	0.32	69.00	3.02	1.20
WAVE	14/09/2022 02:42	0.04	10.70	31	10.974	0.348	62.00	2.97	1.15
WAVE	14/09/2022 02:52	0.06	9.10	169	10.923	0.38	65.00	2.92	1.10
WAVE	14/09/2022 03:02	0.06	3.00	207	10.86	0.372	66.00	2.86	1.04
WAVE	14/09/2022 03:12	0.04	10.70	83	10.796	0.427	67.00	2.80	0.98
WAVE	14/09/2022 03:22	0.04	12.80	335	10.727	0.438	66.00	2.73	0.91
WAVE	14/09/2022 03:32	0.05	3.00	169	10.645	0.478	63.00	2.65	0.83
WAVE	14/09/2022 03:42	0.08	2.30	239	10.563	0.461	68.00	2.56	0.74
WAVE	14/09/2022 03:52	0.06	5.30	359	10.477	0.465	74.00	2.48	0.66
WAVE	14/09/2022 04:02	0.04	9.10	27	10.38	0.4	79.00	2.38	0.56
WAVE	14/09/2022 04:12	0.09	2.10	87	10.281	0.416	80.00	2.28	0.46
WAVE	14/09/2022 04:22	0.05	9.10	99	10.177	0.38	87.00	2.18	0.36
WAVE	14/09/2022 04:32	0.03	9.10	263	10.078	0.36	98.00	2.08	0.26
WAVE	14/09/2022 04:42	0.06	2.90	43	9.973	0.383	99.00	1.97	0.15

Name	Date Time	Significant Height(m)	Peak Time(sec)	Peak Direction (degree)	ADCP Depth(m)	Current Speed(m/s)	Current Direction (degree)	water level reference to CD	water level reference to 1.82 SHD
WAVE	14/09/2022 04:52	0.06	12.80	283	9.869	0.384	93.00	1.87	0.05
WAVE	14/09/2022 05:02	0.06	9.10	169	9.759	0.382	94.00	1.76	-0.06
WAVE	14/09/2022 05:12	0.08	2.10	169	9.651	0.389	87.00	1.65	-0.17
WAVE	14/09/2022 05:22	0.12	2.20	59	9.546	0.367	91.00	1.55	-0.27
WAVE	14/09/2022 05:32	0.07	9.10	35	9.437	0.355	90.00	1.44	-0.38
WAVE	14/09/2022 05:42	0.05	7.10	163	9.337	0.346	89.00	1.34	-0.48
WAVE	14/09/2022 05:52	0.03	16.00	303	9.232	0.336	89.00	1.23	-0.59
WAVE	14/09/2022 06:02	0.12	2.80	88	9.14	0.294	82.00	1.14	-0.68
WAVE	14/09/2022 06:12	0.06	2.60	191	9.049	0.277	81.00	1.05	-0.77
WAVE	14/09/2022 06:22	0.05	12.80	159	8.971	0.211	77.00	0.97	-0.85
WAVE	14/09/2022 06:32	0.05	3.60	119	8.9	0.191	73.00	0.90	-0.92
WAVE	14/09/2022 06:42	0.05	7.10	11	8.841	0.134	81.00	0.84	-0.98
WAVE	14/09/2022 06:52	0.04	6.40	35	8.802	0.126	64.00	0.80	-1.02
WAVE	14/09/2022 07:02	0.07	12.80	123	8.759	0.121	43.00	0.76	-1.06
WAVE	14/09/2022 07:12	0.24	2.10	306	8.733	0.1	347.00	0.73	-1.09
WAVE	14/09/2022 07:22	0.07	2.70	67	8.713	0.109	344.00	0.71	-1.11
WAVE	14/09/2022 07:32	0.10	2.70	230	8.708	0.135	350.00	0.71	-1.11
WAVE	14/09/2022 07:42	0.07	3.80	239	8.706	0.186	342.00	0.71	-1.11
WAVE	14/09/2022 07:52	0.10	2.50	73	8.72	0.133	354.00	0.72	-1.10
WAVE	14/09/2022 08:02	0.22	3.80	244	8.744	0.098	310.00	0.74	-1.08
WAVE	14/09/2022 08:12	0.07	2.90	99	8.771	0.105	267.00	0.77	-1.05
WAVE	14/09/2022 08:22	0.10	3.80	99	8.809	0.112	318.00	0.81	-1.01
WAVE	14/09/2022 08:32	0.07	2.90	95	8.854	0.17	262.00	0.85	-0.97
WAVE	14/09/2022 08:42	0.07	2.50	155	8.903	0.178	260.00	0.90	-0.92
WAVE	14/09/2022 08:52	0.06	3.00	83	8.949	0.14	265.00	0.95	-0.87
WAVE	14/09/2022 09:02	0.09	2.00	7	9.02	0.131	264.00	1.02	-0.80
WAVE	14/09/2022 09:12	0.22	2.70	99	9.072	0.127	269.00	1.07	-0.75
WAVE	14/09/2022 09:22	0.26	2.90	108	9.151	0.128	269.00	1.15	-0.67
WAVE	14/09/2022 09:32	0.08	2.90	101	9.217	0.181	256.00	1.22	-0.60
WAVE	14/09/2022 09:42	0.18	2.50	319	9.293	0.19	252.00	1.29	-0.53
WAVE	14/09/2022 09:52	0.19	2.10	291	9.367	0.246	259.00	1.37	-0.45
WAVE	14/09/2022 10:02	0.23	2.80	127	9.444	0.254	265.00	1.44	-0.38
WAVE	14/09/2022 10:12	0.07	4.00	259	9.518	0.35	262.00	1.52	-0.30
WAVE	14/09/2022 10:22	0.07	2.30	171	9.596	0.326	260.00	1.60	-0.22
WAVE	14/09/2022 10:32	0.07	9.10	251	9.675	0.303	257.00	1.68	-0.14
WAVE	14/09/2022 10:42	0.09	3.20	135	9.757	0.267	252.00	1.76	-0.06
WAVE	14/09/2022 10:52	0.05	16.00	139	9.845	0.309	251.00	1.85	0.03
WAVE	14/09/2022 11:02	0.06	2.90	91	9.932	0.298	262.00	1.93	0.11
WAVE	14/09/2022 11:12	0.24	2.10	106	10.026	0.288	255.00	2.03	0.21
WAVE	14/09/2022 11:22	0.04	9.10	163	10.118	0.369	264.00	2.12	0.30
WAVE	14/09/2022 11:32	0.13	2.90	135	10.21	0.368	250.00	2.21	0.39
WAVE	14/09/2022 11:42	0.07	2.70	253	10.304	0.376	253.00	2.30	0.48
WAVE	14/09/2022 11:52	0.05	12.80	169	10.401	0.342	256.00	2.40	0.58
WAVE	14/09/2022 12:02	0.10	3.00	130	10.495	0.276	250.00	2.50	0.67
WAVE	14/09/2022 12:12	0.08	2.50	99	10.589	0.313	250.00	2.59	0.77
WAVE	14/09/2022 12:22	0.08	2.40	263	10.671	0.294	253.00	2.67	0.85
WAVE	14/09/2022 12:32	0.07	16.00	3	10.754	0.334	250.00	2.75	0.93
WAVE	14/09/2022 12:42	0.15	2.80	125	10.815	0.308	252.00	2.82	0.99
WAVE	14/09/2022 12:52	0.10	3.60	113	10.868	0.251	244.00	2.87	1.05
WAVE	14/09/2022 13:02	0.26	2.10	115	10.912	0.212	237.00	2.91	1.09
WAVE	14/09/2022 13:12	0.29	2.10	103	10.939	0.194	232.00	2.94	1.12
WAVE	14/09/2022 13:22	0.22	2.40	127	10.963	0.138	216.00	2.96	1.14
WAVE	14/09/2022 13:32	0.21	2.70	118	10.971	0.095	157.00	2.97	1.15
WAVE	14/09/2022 13:42	0.11	2.40	342	10.983	0.121	137.00	2.98	1.16
WAVE	14/09/2022 13:52	0.13	2.80	82	10.959	0.167	120.00	2.96	1.14
WAVE	14/09/2022 14:02	0.13	3.00	92	10.938	0.192	68.00	2.94	1.12
WAVE	14/09/2022 14:30	0.31	2.90	94	10.782	0.361	33.00	2.78	0.96
WAVE	14/09/2022 14:40	0.19	3.80	88	10.717	0.406	59.00	2.72	0.90
WAVE	14/09/2022 14:50	0.19	3.20	106	10.649	0.423	65.00	2.65	0.83
WAVE	14/09/2022 15:00	0.13	3.00	95	10.573	0.439	80.00	2.57	0.75
WAVE	14/09/2022 15:10	0.11	3.40	87	10.498	0.481	71.00	2.50	0.68
WAVE	14/09/2022 15:20	0.17	2.50	35	10.415	0.452	74.00	2.42	0.59
WAVE	14/09/2022 15:30	0.14	2.90	80	10.322	0.345	80.00	2.32	0.50
WAVE	14/09/2022 15:40	0.14	3.80	98	10.229	0.304	84.00	2.23	0.41

Name	Date Time	Significant Height(m)	Peak Time(sec)	Peak Direction (degree)	ADCP Depth(m)	Current Speed(m/s)	Current Direction (degree)	water level reference to CD	water level reference to 1.82 SHD
WAVE	14/09/2022 15:50	0.12	3.60	87	10.151	0.35	90.00	2.15	0.33
WAVE	14/09/2022 16:00	0.16	3.60	93	10.062	0.317	102.00	2.06	0.24
WAVE	14/09/2022 16:10	0.10	3.60	90	9.973	0.278	101.00	1.97	0.15
WAVE	14/09/2022 16:20	0.13	3.40	100	9.876	0.257	98.00	1.88	0.06
WAVE	14/09/2022 16:30	0.07	4.90	109	9.785	0.247	101.00	1.79	-0.03
WAVE	14/09/2022 16:40	0.12	2.10	87	9.678	0.254	99.00	1.68	-0.14
WAVE	14/09/2022 16:50	0.06	2.90	335	9.585	0.271	101.00	1.59	-0.23
WAVE	14/09/2022 17:00	0.05	4.60	79	9.492	0.285	88.00	1.49	-0.33
WAVE	14/09/2022 17:10	0.14	3.80	119	9.4	0.309	91.00	1.40	-0.42
WAVE	14/09/2022 17:20	0.19	2.60	305	9.302	0.294	83.00	1.30	-0.52
WAVE	14/09/2022 17:30	0.08	2.70	83	9.197	0.35	87.00	1.20	-0.62
WAVE	14/09/2022 17:40	0.10	2.40	307	9.092	0.33	83.00	1.09	-0.73
WAVE	14/09/2022 17:50	0.19	3.40	102	8.998	0.322	89.00	1.00	-0.82
WAVE	14/09/2022 18:18	0.19	16.00	127	8.77	0.18	87.00	0.77	-1.05
WAVE	14/09/2022 18:28	0.07	3.40	103	8.703	0.195	90.00	0.70	-1.12
WAVE	14/09/2022 18:38	0.32	2.00	204	8.64	0.184	79.00	0.64	-1.18
WAVE	14/09/2022 18:48	0.08	2.70	103	8.587	0.068	97.00	0.59	-1.23
WAVE	14/09/2022 18:58	0.11	2.70	99	8.548	0.037	133.00	0.55	-1.27
WAVE	14/09/2022 19:08	0.15	2.20	83	8.509	0.035	234.00	0.51	-1.31
WAVE	14/09/2022 19:18	0.14	2.30	85	8.488	0.072	248.00	0.49	-1.33
WAVE	14/09/2022 19:28	0.10	2.50	19	8.484	0.139	260.00	0.48	-1.34
WAVE	14/09/2022 19:38	0.14	2.10	87	8.481	0.152	273.00	0.48	-1.34
WAVE	14/09/2022 19:48	0.13	2.30	67	8.505	0.193	263.00	0.51	-1.32
WAVE	14/09/2022 19:58	0.25	1.90	74	8.52	0.237	267.00	0.52	-1.30
WAVE	14/09/2022 20:08	0.14	2.10	91	8.57	0.198	269.00	0.57	-1.25
WAVE	14/09/2022 20:18	0.16	2.10	208	8.608	0.225	273.00	0.61	-1.21
WAVE	14/09/2022 20:28	0.11	2.40	111	8.664	0.27	259.00	0.66	-1.16
WAVE	14/09/2022 20:38	0.13	2.00	79	8.724	0.288	259.00	0.72	-1.10
WAVE	14/09/2022 20:48	0.15	2.00	91	8.783	0.23	277.00	0.78	-1.04
WAVE	14/09/2022 20:58	0.10	2.10	111	8.85	0.292	264.00	0.85	-0.97
WAVE	14/09/2022 21:08	0.06	10.70	319	8.913	0.244	269.00	0.91	-0.91
WAVE	14/09/2022 21:18	0.07	2.60	107	8.978	0.266	264.00	0.98	-0.84
WAVE	14/09/2022 21:28	0.05	12.80	327	9.042	0.262	260.00	1.04	-0.78
WAVE	14/09/2022 21:38	0.06	8.00	169	9.102	0.258	259.00	1.10	-0.72
WAVE	14/09/2022 21:48	0.08	2.90	151	9.189	0.276	269.00	1.19	-0.63
WAVE	14/09/2022 21:58	0.03	9.10	169	9.265	0.374	261.00	1.27	-0.55
WAVE	14/09/2022 22:08	0.02	9.10	283	9.336	0.443	268.00	1.34	-0.48
WAVE	14/09/2022 22:18	0.07	16.00	169	9.405	0.375	271.00	1.41	-0.42
WAVE	14/09/2022 22:28	0.10	2.50	91	9.477	0.301	260.00	1.48	-0.34
WAVE	14/09/2022 22:38	0.06	2.80	106	9.539	0.308	268.00	1.54	-0.28
WAVE	14/09/2022 22:48	0.06	9.10	169	9.608	0.282	264.00	1.61	-0.21
WAVE	14/09/2022 22:58	0.06	3.00	345	9.684	0.325	262.00	1.68	-0.14
WAVE	14/09/2022 23:08	0.11	2.30	347	9.768	0.357	263.00	1.77	-0.05
WAVE	14/09/2022 23:18	0.06	2.50	103	9.852	0.338	257.00	1.85	0.03
WAVE	14/09/2022 23:28	0.05	8.00	323	9.935	0.31	256.00	1.94	0.12
WAVE	14/09/2022 23:38	0.11	4.60	225	10.021	0.26	245.00	2.02	0.20
WAVE	14/09/2022 23:48	0.19	2.10	167	10.094	0.275	245.00	2.09	0.27
WAVE	14/09/2022 23:58	0.03	21.30	169	10.181	0.299	247.00	2.18	0.36
WAVE	15/09/2022 00:08	0.06	12.80	91	10.261	0.308	252.00	2.26	0.44
WAVE	15/09/2022 00:18	0.08	3.20	115	10.352	0.314	255.00	2.35	0.53
WAVE	15/09/2022 00:28	0.08	2.40	351	10.453	0.312	253.00	2.45	0.63
WAVE	15/09/2022 00:38	0.16	3.60	205	10.531	0.328	255.00	2.53	0.71
WAVE	15/09/2022 00:48	0.06	3.20	67	10.613	0.287	262.00	2.61	0.79
WAVE	15/09/2022 00:58	0.06	9.10	91	10.675	0.257	255.00	2.68	0.86
WAVE	15/09/2022 01:08	0.07	2.60	99	10.737	0.234	256.00	2.74	0.92
WAVE	15/09/2022 01:18	0.02	9.10	159	10.782	0.231	256.00	2.78	0.96
WAVE	15/09/2022 01:28	0.04	9.10	227	10.819	0.223	251.00	2.82	1.00
WAVE	15/09/2022 01:38	0.02	21.30	211	10.855	0.178	246.00	2.86	1.04
WAVE	15/09/2022 01:48	0.04	12.80	131	10.888	0.127	237.00	2.89	1.07
WAVE	15/09/2022 01:58	0.06	3.60	151	10.897	0.07	202.00	2.90	1.08
WAVE	15/09/2022 02:08	0.05	3.00	143	10.91	0.068	156.00	2.91	1.09
WAVE	15/09/2022 02:18	0.10	2.60	195	10.91	0.114	135.00	2.91	1.09
WAVE	15/09/2022 02:28	0.05	3.20	105	10.908	0.105	123.00	2.91	1.09
WAVE	15/09/2022 02:38	0.07	9.10	169	10.897	0.168	106.00	2.90	1.08

Name	Date Time	Significant Height(m)	Peak Time(sec)	Peak Direction (degree)	ADCP Depth(m)	Current Speed(m/s)	Current Direction (degree)	water level reference to CD	water level reference to 1.82 SHD
WAVE	15/09/2022 02:48	0.06	16.00	111	10.878	0.222	103.00	2.88	1.06
WAVE	15/09/2022 02:58	0.02	12.80	51	10.841	0.353	65.00	2.84	1.02
WAVE	15/09/2022 03:37	0.11	5.80	287	10.639	0.532	73.00	2.64	0.82
WAVE	15/09/2022 03:47	0.03	9.10	169	10.587	0.384	69.00	2.59	0.77
WAVE	15/09/2022 03:57	0.06	3.40	69	10.525	0.449	71.00	2.53	0.71
WAVE	15/09/2022 04:07	0.07	2.90	105	10.47	0.465	69.00	2.47	0.65
WAVE	15/09/2022 04:17	0.15	2.00	171	10.392	0.414	72.00	2.39	0.57
WAVE	15/09/2022 04:27	0.04	9.10	291	10.307	0.306	73.00	2.31	0.49
WAVE	15/09/2022 04:37	0.03	16.00	19	10.225	0.31	76.00	2.23	0.41
WAVE	15/09/2022 04:47	0.07	5.30	19	10.136	0.296	71.00	2.14	0.32
WAVE	15/09/2022 04:57	0.06	10.70	351	10.041	0.337	85.00	2.04	0.22
WAVE	15/09/2022 05:07	0.05	5.80	259	9.954	0.348	91.00	1.95	0.13
WAVE	15/09/2022 05:17	0.07	2.60	185	9.86	0.357	92.00	1.86	0.04
WAVE	15/09/2022 05:27	0.07	2.90	163	9.764	0.356	96.00	1.76	-0.06
WAVE	15/09/2022 05:37	0.13	2.10	19	9.667	0.353	92.00	1.67	-0.15
WAVE	15/09/2022 05:47	0.04	5.80	43	9.568	0.365	91.00	1.57	-0.25
WAVE	15/09/2022 05:57	0.08	2.60	75	9.485	0.342	95.00	1.49	-0.34
WAVE	15/09/2022 06:07	0.05	2.30	135	9.404	0.32	96.00	1.40	-0.42
WAVE	15/09/2022 06:17	0.06	3.00	115	9.307	0.317	95.00	1.31	-0.51
WAVE	15/09/2022 06:27	0.05	10.70	103	9.223	0.285	92.00	1.22	-0.60
WAVE	15/09/2022 06:37	0.09	3.20	55	9.15	0.256	93.00	1.15	-0.67
WAVE	15/09/2022 06:47	0.04	10.70	103	9.08	0.254	85.00	1.08	-0.74
WAVE	15/09/2022 06:57	0.07	2.90	103	9.015	0.2	80.00	1.02	-0.80
WAVE	15/09/2022 07:07	0.07	9.10	307	8.963	0.169	80.00	0.96	-0.86
WAVE	15/09/2022 07:17	0.10	2.10	311	8.925	0.062	79.00	0.93	-0.89
WAVE	15/09/2022 07:27	0.06	3.20	91	8.89	0.031	353.00	0.89	-0.93
WAVE	15/09/2022 07:37	0.10	2.20	267	8.872	0.041	350.00	0.87	-0.95
WAVE	15/09/2022 07:47	0.11	2.80	117	8.859	0.084	307.00	0.86	-0.96
WAVE	15/09/2022 07:57	0.12	2.10	219	8.851	0.101	302.00	0.85	-0.97
WAVE	15/09/2022 08:07	0.07	2.80	87	8.861	0.103	325.00	0.86	-0.96
WAVE	15/09/2022 08:17	0.11	2.80	257	8.868	0.123	330.00	0.87	-0.95
WAVE	15/09/2022 08:27	0.07	2.80	77	8.88	0.114	320.00	0.88	-0.94
WAVE	15/09/2022 08:37	0.17	2.10	103	8.9	0.08	316.00	0.90	-0.92
WAVE	15/09/2022 08:47	0.11	4.00	239	8.923	0.146	248.00	0.92	-0.90
WAVE	15/09/2022 08:57	0.11	9.10	199	8.957	0.117	267.00	0.96	-0.86
WAVE	15/09/2022 09:07	0.03	16.00	271	9.003	0.064	282.00	1.00	-0.82
WAVE	15/09/2022 09:17	0.11	2.70	105	9.041	0.07	299.00	1.04	-0.78
WAVE	15/09/2022 09:27	0.13	2.60	100	9.087	0.052	300.00	1.09	-0.73
WAVE	15/09/2022 09:37	0.05	9.10	19	9.136	0.069	294.00	1.14	-0.68
WAVE	15/09/2022 09:47	0.06	3.00	191	9.182	0.069	284.00	1.18	-0.64
WAVE	15/09/2022 09:57	0.12	2.70	315	9.245	0.093	273.00	1.25	-0.58
WAVE	15/09/2022 10:07	0.17	2.90	108	9.305	0.095	307.00	1.31	-0.52
WAVE	15/09/2022 10:17	0.06	16.00	91	9.354	0.117	296.00	1.35	-0.47
WAVE	15/09/2022 10:27	0.07	2.30	211	9.429	0.147	271.00	1.43	-0.39
WAVE	15/09/2022 10:37	0.09	2.30	101	9.494	0.214	261.00	1.49	-0.33
WAVE	15/09/2022 10:47	0.12	2.10	343	9.559	0.227	266.00	1.56	-0.26
WAVE	15/09/2022 10:57	0.05	9.10	67	9.628	0.307	262.00	1.63	-0.19
WAVE	15/09/2022 11:07	0.08	2.80	296	9.703	0.337	268.00	1.70	-0.12
WAVE	15/09/2022 11:17	0.14	2.70	8	9.785	0.31	255.00	1.79	-0.03
WAVE	15/09/2022 11:27	0.07	3.40	187	9.863	0.338	261.00	1.86	0.04
WAVE	15/09/2022 11:37	0.14	3.00	129	9.953	0.347	255.00	1.95	0.13
WAVE	15/09/2022 11:47	0.15	2.90	148	10.045	0.389	259.00	2.05	0.23
WAVE	15/09/2022 11:57	0.07	10.70	265	10.144	0.388	257.00	2.14	0.32
WAVE	15/09/2022 12:07	0.06	9.10	63	10.239	0.365	250.00	2.24	0.42
WAVE	15/09/2022 12:17	0.09	3.20	291	10.341	0.38	255.00	2.34	0.52
WAVE	15/09/2022 12:27	0.08	2.60	111	10.426	0.35	257.00	2.43	0.61
WAVE	15/09/2022 12:37	0.07	2.80	115	10.5	0.277	263.00	2.50	0.68
WAVE	15/09/2022 12:47	0.06	2.80	147	10.579	0.281	256.00	2.58	0.76
WAVE	15/09/2022 12:57	0.20	2.50	127	10.654	0.283	250.00	2.65	0.83
WAVE	15/09/2022 13:07	0.05	16.00	3	10.7	0.252	254.00	2.70	0.88
WAVE	15/09/2022 13:17	0.28	3.20	290	10.75	0.227	254.00	2.75	0.93
WAVE	15/09/2022 13:27	0.14	2.10	137	10.784	0.174	255.00	2.78	0.96
WAVE	15/09/2022 13:37	0.06	3.60	79	10.806	0.092	249.00	2.81	0.99
WAVE	15/09/2022 13:47	0.13	2.70	111	10.823	0.061	197.00	2.82	1.00

Name	Date Time	Significant Height(m)	Peak Time(sec)	Peak Direction (degree)	ADCP Depth(m)	Current Speed(m/s)	Current Direction (degree)	water level reference to CD	water level reference to 1.82 SHD
WAVE	15/09/2022 13:57	0.08	2.90	263	10.828	0.049	160.00	2.83	1.01
WAVE	15/09/2022 14:07	0.06	21.30	27	10.827	0.086	115.00	2.83	1.01
WAVE	15/09/2022 14:17	0.09	2.60	195	10.813	0.262	67.00	2.81	0.99
WAVE	15/09/2022 14:27	0.06	3.20	95	10.792	0.279	75.00	2.79	0.97
WAVE	15/09/2022 14:37	0.05	3.20	199	10.769	0.31	78.00	2.77	0.95
WAVE	15/09/2022 14:47	0.27	3.00	311	10.724	0.322	76.00	2.72	0.90
WAVE	15/09/2022 14:57	0.08	2.60	83	10.685	0.319	57.00	2.69	0.87
WAVE	15/09/2022 15:07	0.15	2.50	283	10.635	0.353	64.00	2.64	0.82
WAVE	15/09/2022 15:17	0.10	2.90	99	10.578	0.412	70.00	2.58	0.76
WAVE	15/09/2022 15:27	0.05	4.30	107	10.519	0.501	71.00	2.52	0.70
WAVE	15/09/2022 15:37	0.11	2.30	27	10.467	0.468	77.00	2.47	0.65
WAVE	15/09/2022 15:47	0.13	3.00	91	10.393	0.467	76.00	2.39	0.57
WAVE	15/09/2022 15:57	0.22	3.20	223	10.334	0.405	72.00	2.33	0.51
WAVE	15/09/2022 16:07	0.14	3.60	109	10.255	0.417	68.00	2.26	0.44
WAVE	15/09/2022 16:17	0.18	2.40	143	10.178	0.379	68.00	2.18	0.36
WAVE	15/09/2022 16:27	0.12	2.70	88	10.103	0.267	89.00	2.10	0.28
WAVE	15/09/2022 16:37	0.16	2.80	307	10.025	0.258	66.00	2.03	0.21
WAVE	15/09/2022 16:47	0.10	3.40	87	9.938	0.308	61.00	1.94	0.12
WAVE	15/09/2022 16:57	0.12	2.10	79	9.85	0.167	60.00	1.85	0.03
WAVE	15/09/2022 17:07	0.10	2.10	90	9.767	0.172	61.00	1.77	-0.05
WAVE	15/09/2022 17:17	0.02	9.10	169	9.68	0.213	94.00	1.68	-0.14
WAVE	15/09/2022 17:27	0.08	2.90	101	9.591	0.272	90.00	1.59	-0.23
WAVE	15/09/2022 17:37	0.17	3.20	209	9.486	0.284	89.00	1.49	-0.33
WAVE	15/09/2022 17:47	0.08	2.60	31	9.391	0.293	90.00	1.39	-0.43
WAVE	15/09/2022 17:57	0.09	2.80	312	9.305	0.308	90.00	1.31	-0.52
WAVE	15/09/2022 18:07	0.13	2.60	292	9.209	0.314	90.00	1.21	-0.61
WAVE	15/09/2022 18:17	0.07	2.80	75	9.12	0.302	86.00	1.12	-0.70
WAVE	15/09/2022 18:27	0.05	3.80	83	9.025	0.295	85.00	1.03	-0.80
WAVE	15/09/2022 18:37	0.08	3.00	95	8.953	0.251	85.00	0.95	-0.87
WAVE	15/09/2022 18:47	0.17	2.50	294	8.874	0.209	83.00	0.87	-0.95
WAVE	15/09/2022 18:57	0.08	2.40	183	8.809	0.185	100.00	0.81	-1.01
WAVE	15/09/2022 19:07	0.09	2.70	113	8.757	0.146	90.00	0.76	-1.06
WAVE	15/09/2022 19:17	0.09	2.30	129	8.707	0.061	151.00	0.71	-1.11
WAVE	15/09/2022 19:27	0.14	2.70	241	8.671	0.021	110.00	0.67	-1.15
WAVE	15/09/2022 19:37	0.06	7.10	263	8.635	0.031	230.00	0.64	-1.19
WAVE	15/09/2022 19:47	0.10	2.70	86	8.61	0.098	244.00	0.61	-1.21
WAVE	15/09/2022 19:57	0.06	9.10	71	8.593	0.077	263.00	0.59	-1.23
WAVE	15/09/2022 20:07	0.12	3.80	199	8.574	0.106	274.00	0.57	-1.25
WAVE	15/09/2022 20:17	0.07	3.20	71	8.567	0.1	266.00	0.57	-1.25
WAVE	15/09/2022 20:27	0.05	12.80	223	8.573	0.052	297.00	0.57	-1.25
WAVE	15/09/2022 20:37	0.05	4.00	87	8.589	0.11	335.00	0.59	-1.23
WAVE	15/09/2022 20:47	0.07	2.90	113	8.606	0.084	283.00	0.61	-1.21
WAVE	15/09/2022 20:57	0.09	2.60	99	8.637	0.106	314.00	0.64	-1.18
WAVE	15/09/2022 21:07	0.07	2.60	87	8.662	0.092	323.00	0.66	-1.16
WAVE	15/09/2022 21:17	0.06	3.00	95	8.696	0.114	332.00	0.70	-1.12
WAVE	15/09/2022 21:27	0.06	7.10	143	8.727	0.092	318.00	0.73	-1.09
WAVE	15/09/2022 21:37	0.05	21.30	99	8.772	0.064	300.00	0.77	-1.05
WAVE	15/09/2022 21:47	0.05	8.00	265	8.827	0.071	298.00	0.83	-0.99
WAVE	15/09/2022 21:57	0.06	16.00	119	8.868	0.09	302.00	0.87	-0.95
WAVE	15/09/2022 22:07	0.04	9.10	355	8.924	0.106	283.00	0.92	-0.90
WAVE	15/09/2022 22:17	0.06	2.50	279	8.98	0.128	281.00	0.98	-0.84
WAVE	15/09/2022 22:27	0.06	2.50	95	9.052	0.171	271.00	1.05	-0.77
WAVE	15/09/2022 22:37	0.20	2.60	101	9.12	0.221	264.00	1.12	-0.70
WAVE	15/09/2022 22:47	0.05	16.00	169	9.199	0.253	261.00	1.20	-0.62
WAVE	15/09/2022 22:57	0.08	2.30	91	9.273	0.352	255.00	1.27	-0.55
WAVE	15/09/2022 23:07	0.07	2.30	215	9.351	0.354	256.00	1.35	-0.47
WAVE	15/09/2022 23:17	0.05	9.10	169	9.432	0.357	253.00	1.43	-0.39
WAVE	15/09/2022 23:27	0.04	16.00	87	9.515	0.381	258.00	1.52	-0.30
WAVE	15/09/2022 23:37	0.08	2.50	100	9.521	0.382	260.00	1.52	-0.30
WAVE	15/09/2022 23:47	0.34	4.90	335	9.685	0.408	265.00	1.69	-0.14
WAVE	15/09/2022 23:57	0.08	2.50	279	9.777	0.38	261.00	1.78	-0.04
WAVE	16/09/2022 00:07	0.06	12.80	7	9.865	0.329	258.00	1.87	0.05
WAVE	16/09/2022 00:17	0.05	8.00	235	9.961	0.309	254.00	1.96	0.14
WAVE	16/09/2022 00:27	0.03	9.10	119	10.047	0.353	257.00	2.05	0.23

Name	Date Time	Significant Height(m)	Peak Time(sec)	Peak Direction (degree)	ADCP Depth(m)	Current Speed(m/s)	Current Direction (degree)	water level reference to CD	water level reference to 1.82 SHD
WAVE	16/09/2022 00:37	0.04	10.70	47	10.144	0.358	254.00	2.14	0.32
WAVE	16/09/2022 00:47	0.06	2.80	75	10.236	0.359	255.00	2.24	0.42
WAVE	16/09/2022 00:57	0.10	2.10	295	10.317	0.331	261.00	2.32	0.50
WAVE	16/09/2022 01:07	0.08	21.30	279	10.412	0.305	260.00	2.41	0.59
WAVE	16/09/2022 01:17	0.05	9.10	81	10.485	0.287	261.00	2.49	0.66
WAVE	16/09/2022 01:27	0.04	3.80	83	10.553	0.285	250.00	2.55	0.73
WAVE	16/09/2022 01:37	0.06	21.30	169	10.616	0.276	256.00	2.62	0.80
WAVE	16/09/2022 01:47	0.06	9.10	263	10.668	0.261	255.00	2.67	0.85
WAVE	16/09/2022 01:57	0.06	12.80	347	10.72	0.201	261.00	2.72	0.90
WAVE	16/09/2022 02:07	0.08	12.80	115	10.754	0.181	251.00	2.75	0.93
WAVE	16/09/2022 02:17	0.08	2.30	103	10.784	0.151	253.00	2.78	0.96
WAVE	16/09/2022 02:27	0.06	2.70	203	10.806	0.119	235.00	2.81	0.99
WAVE	16/09/2022 02:37	0.11	2.20	241	10.824	0.07	249.00	2.82	1.00
WAVE	16/09/2022 02:47	0.07	4.30	7	10.837	0.048	240.00	2.84	1.02
WAVE	16/09/2022 02:57	0.03	16.00	79	10.843	0.035	168.00	2.84	1.02
WAVE	16/09/2022 03:07	0.03	16.00	155	10.828	0.085	117.00	2.83	1.01
WAVE	16/09/2022 03:17	0.05	10.70	203	10.814	0.11	107.00	2.81	0.99
WAVE	16/09/2022 03:27	0.09	2.20	207	10.795	0.152	100.00	2.80	0.98
WAVE	16/09/2022 03:37	0.02	21.30	163	10.766	0.338	73.00	2.77	0.95
WAVE	16/09/2022 03:47	0.04	10.70	95	10.738	0.3	70.00	2.74	0.92
WAVE	16/09/2022 03:57	0.05	12.80	123	10.694	0.328	64.00	2.69	0.87
WAVE	16/09/2022 04:07	0.05	10.70	275	10.656	0.373	63.00	2.66	0.84
WAVE	16/09/2022 04:17	0.08	2.70	191	10.607	0.351	71.00	2.61	0.79
WAVE	16/09/2022 04:27	0.04	9.10	159	10.553	0.417	63.00	2.55	0.73
WAVE	16/09/2022 04:37	0.06	21.30	169	10.495	0.404	65.00	2.50	0.67
WAVE	16/09/2022 04:47	0.08	2.10	99	10.441	0.413	70.00	2.44	0.62
WAVE	16/09/2022 04:57	0.04	16.00	107	10.377	0.36	67.00	2.38	0.56
WAVE	16/09/2022 05:07	0.20	3.20	99	10.31	0.355	71.00	2.31	0.49
WAVE	16/09/2022 05:17	0.06	4.60	169	10.234	0.301	79.00	2.23	0.41
WAVE	16/09/2022 05:27	0.08	2.40	275	10.149	0.281	85.00	2.15	0.33
WAVE	16/09/2022 05:37	0.05	9.10	311	10.075	0.294	88.00	2.08	0.25
WAVE	16/09/2022 05:47	0.06	7.10	275	9.999	0.304	91.00	2.00	0.18
WAVE	16/09/2022 05:57	0.07	2.30	163	9.923	0.313	100.00	1.92	0.10
WAVE	16/09/2022 06:07	0.07	16.00	43	9.841	0.313	102.00	1.84	0.02
WAVE	16/09/2022 06:17	0.07	9.10	223	9.763	0.288	97.00	1.76	-0.06
WAVE	16/09/2022 06:27	0.07	3.00	103	9.692	0.29	87.00	1.69	-0.13
WAVE	16/09/2022 06:37	0.04	3.80	279	9.616	0.258	86.00	1.62	-0.20
WAVE	16/09/2022 06:47	0.10	1.90	131	9.545	0.227	95.00	1.55	-0.28
WAVE	16/09/2022 06:57	0.06	16.00	79	9.473	0.207	96.00	1.47	-0.35
WAVE	16/09/2022 07:07	0.08	3.00	95	9.404	0.233	85.00	1.40	-0.42
WAVE	16/09/2022 07:17	0.07	2.80	79	9.347	0.19	86.00	1.35	-0.47
WAVE	16/09/2022 07:27	0.05	9.10	11	9.301	0.158	89.00	1.30	-0.52
WAVE	16/09/2022 07:37	0.13	2.60	91	9.266	0.165	66.00	1.27	-0.55
WAVE	16/09/2022 07:47	0.07	3.20	127	9.237	0.099	48.00	1.24	-0.58
WAVE	16/09/2022 07:57	0.19	3.00	110	9.219	0.054	43.00	1.22	-0.60
WAVE	16/09/2022 08:07	0.12	2.50	255	9.205	0.058	1.00	1.21	-0.62
WAVE	16/09/2022 08:17	0.12	2.70	95	9.197	0.088	1.00	1.20	-0.62
WAVE	16/09/2022 08:27	0.08	2.10	203	9.184	0.087	339.00	1.18	-0.64
WAVE	16/09/2022 08:37	0.07	2.90	287	9.189	0.089	320.00	1.19	-0.63
WAVE	16/09/2022 08:47	0.10	2.20	219	9.207	0.082	341.00	1.21	-0.61
WAVE	16/09/2022 08:57	0.05	9.10	51	9.221	0.1	247.00	1.22	-0.60
WAVE	16/09/2022 09:07	0.10	2.60	115	9.254	0.089	256.00	1.25	-0.57
WAVE	16/09/2022 09:17	0.31	2.80	95	9.28	0.065	268.00	1.28	-0.54
WAVE	16/09/2022 09:27	0.24	2.70	104	9.323	0.064	280.00	1.32	-0.50
WAVE	16/09/2022 09:37	0.04	4.60	151	9.348	0.05	295.00	1.35	-0.47
WAVE	16/09/2022 09:47	0.08	3.00	115	9.394	0.044	318.00	1.39	-0.43
WAVE	16/09/2022 09:57	0.04	12.80	275	9.421	0.064	330.00	1.42	-0.40
WAVE	16/09/2022 10:07	0.13	2.70	105	9.466	0.036	280.00	1.47	-0.35
WAVE	16/09/2022 10:17	0.08	2.80	117	9.496	0.072	310.00	1.50	-0.32
WAVE	16/09/2022 10:27	0.07	2.50	247	9.544	0.048	276.00	1.54	-0.28
WAVE	16/09/2022 10:37	0.05	9.10	91	9.581	0.086	276.00	1.58	-0.24
WAVE	16/09/2022 10:47	0.07	2.80	87	9.634	0.076	247.00	1.63	-0.19
WAVE	16/09/2022 10:57	0.11	2.70	129	9.677	0.106	253.00	1.68	-0.14
WAVE	16/09/2022 11:07	0.15	2.20	71	9.719	0.14	275.00	1.72	-0.10

Name	Date Time	Significant Height(m)	Peak Time(sec)	Peak Direction (degree)	ADCP Depth(m)	Current Speed(m/s)	Current Direction (degree)	water level reference to CD	water level reference to 1.82 SHD
WAVE	16/09/2022 11:17	0.08	2.40	43	9.759	0.157	271.00	1.76	-0.06
WAVE	16/09/2022 11:27	0.07	2.70	207	9.814	0.185	267.00	1.81	-0.01
WAVE	16/09/2022 11:37	0.14	2.90	117	9.878	0.18	261.00	1.88	0.06
WAVE	16/09/2022 11:47	0.08	2.10	27	9.949	0.211	256.00	1.95	0.13
WAVE	16/09/2022 11:57	0.17	2.90	127	10.021	0.215	256.00	2.02	0.20
WAVE	16/09/2022 12:07	0.08	2.70	112	10.102	0.249	249.00	2.10	0.28
WAVE	16/09/2022 12:17	0.08	3.40	140	10.18	0.261	250.00	2.18	0.36
WAVE	16/09/2022 12:27	0.06	3.40	104	10.26	0.26	255.00	2.26	0.44
WAVE	16/09/2022 12:37	0.27	3.20	121	10.338	0.295	257.00	2.34	0.52
WAVE	16/09/2022 12:47	0.11	2.50	76	10.407	0.283	249.00	2.41	0.59
WAVE	16/09/2022 12:57	0.19	3.00	119	10.475	0.233	254.00	2.48	0.66
WAVE	16/09/2022 13:07	0.14	2.80	136	10.541	0.221	265.00	2.54	0.72
WAVE	16/09/2022 13:30	0.05	21.30	56	10.67	0.128	250.00	2.67	0.85
WAVE	16/09/2022 13:40	0.34	2.90	124	10.701	0.131	258.00	2.70	0.88
WAVE	16/09/2022 13:50	0.27	2.90	112	10.739	0.095	232.00	2.74	0.92
WAVE	16/09/2022 14:00	0.10	2.10	231	10.759	0.105	222.00	2.76	0.94
WAVE	16/09/2022 14:10	0.11	2.30	51	10.788	0.072	145.00	2.79	0.97
WAVE	16/09/2022 14:20	0.07	4.30	85	10.803	0.059	145.00	2.80	0.98
WAVE	16/09/2022 14:30	0.05	4.60	79	10.796	0.058	111.00	2.80	0.98
WAVE	16/09/2022 15:08	0.04	9.10	169	10.727	0.35	53.00	2.73	0.91
WAVE	16/09/2022 15:18	0.07	2.80	119	10.696	0.244	86.00	2.70	0.88
WAVE	16/09/2022 15:28	0.03	10.70	169	10.647	0.366	81.00	2.65	0.83
WAVE	16/09/2022 15:38	0.02	9.10	169	10.606	0.297	57.00	2.61	0.79
WAVE	16/09/2022 15:48	0.07	3.40	131	10.56	0.344	77.00	2.56	0.74
WAVE	16/09/2022 15:58	0.07	9.10	311	10.513	0.355	75.00	2.51	0.69
WAVE	16/09/2022 16:08	0.07	3.40	71	10.457	0.369	78.00	2.46	0.64
WAVE	16/09/2022 16:18	0.13	2.90	91	10.393	0.387	77.00	2.39	0.57
WAVE	16/09/2022 16:42	0.04	10.70	319	10.222	0.45	76.00	2.22	0.40
WAVE	16/09/2022 16:52	0.11	2.70	103	10.141	0.348	78.00	2.14	0.32
WAVE	16/09/2022 17:02	0.06	2.90	259	10.052	0.361	74.00	2.05	0.23
WAVE	16/09/2022 17:12	0.09	2.70	83	9.962	0.346	68.00	1.96	0.14
WAVE	16/09/2022 17:22	0.29	2.90	299	9.883	0.32	63.00	1.88	0.06
WAVE	16/09/2022 17:32	0.07	3.20	85	9.796	0.343	64.00	1.80	-0.02
WAVE	16/09/2022 17:42	0.03	10.70	135	9.709	0.252	66.00	1.71	-0.11
WAVE	16/09/2022 17:52	0.10	3.00	83	9.622	0.194	75.00	1.62	-0.20
WAVE	16/09/2022 18:02	0.12	2.50	189	9.546	0.306	87.00	1.55	-0.27
WAVE	16/09/2022 18:12	0.08	3.60	87	9.461	0.313	83.00	1.46	-0.36
WAVE	16/09/2022 18:22	0.06	3.00	79	9.37	0.272	88.00	1.37	-0.45
WAVE	16/09/2022 18:32	0.06	9.10	139	9.274	0.259	90.00	1.27	-0.55
WAVE	16/09/2022 18:42	0.11	2.60	283	9.19	0.238	93.00	1.19	-0.63
WAVE	16/09/2022 18:52	0.09	2.50	355	9.116	0.215	90.00	1.12	-0.70
WAVE	16/09/2022 19:02	0.08	2.50	357	9.036	0.192	97.00	1.04	-0.78
WAVE	16/09/2022 19:12	0.07	2.70	169	8.965	0.172	98.00	0.97	-0.86
WAVE	16/09/2022 19:22	0.06	9.10	7	8.897	0.121	102.00	0.90	-0.92
WAVE	16/09/2022 19:32	0.07	2.40	275	8.846	0.092	124.00	0.85	-0.97
WAVE	16/09/2022 19:42	0.07	2.60	79	8.795	0.071	56.00	0.80	-1.03
WAVE	16/09/2022 19:52	0.09	3.40	245	8.765	0.042	64.00	0.77	-1.06
WAVE	16/09/2022 20:02	0.03	9.10	35	8.727	0.043	37.00	0.73	-1.09
WAVE	16/09/2022 20:12	0.07	3.80	103	8.705	0.026	254.00	0.71	-1.12
WAVE	16/09/2022 20:22	0.05	21.30	223	8.679	0.045	308.00	0.68	-1.14
WAVE	16/09/2022 20:32	0.11	2.10	87	8.663	0.065	325.00	0.66	-1.16
WAVE	16/09/2022 20:42	0.15	2.20	103	8.642	0.078	289.00	0.64	-1.18
WAVE	16/09/2022 20:52	0.07	2.90	91	8.646	0.114	268.00	0.65	-1.17
WAVE	16/09/2022 21:02	0.11	2.20	75	8.641	0.064	314.00	0.64	-1.18
WAVE	16/09/2022 21:12	0.06	16.00	311	8.65	0.025	324.00	0.65	-1.17
WAVE	16/09/2022 21:22	0.07	2.10	229	8.667	0.047	240.00	0.67	-1.15
WAVE	16/09/2022 21:32	0.09	2.90	85	8.69	0.035	272.00	0.69	-1.13
WAVE	16/09/2022 21:42	0.10	2.60	85	8.721	0.044	320.00	0.72	-1.10
WAVE	16/09/2022 21:52	0.05	4.00	187	8.749	0.039	276.00	0.75	-1.07
WAVE	16/09/2022 22:02	0.06	2.70	83	8.788	0.006	353.00	0.79	-1.03
WAVE	16/09/2022 22:12	0.34	2.80	129	8.816	0.019	254.00	0.82	-1.00
WAVE	16/09/2022 22:22	0.08	2.10	99	8.866	0.028	9.00	0.87	-0.95
WAVE	16/09/2022 22:32	0.07	10.70	107	8.905	0.021	333.00	0.90	-0.92
WAVE	16/09/2022 22:42	0.08	2.30	43	8.953	0.075	266.00	0.95	-0.87

Name	Date Time	Significant Height(m)	Peak Time(sec)	Peak Direction (degree)	ADCP Depth(m)	Current Speed(m/s)	Current Direction (degree)	water level reference to CD	water level reference to 1.82 SHD
WAVE	16/09/2022 22:52	0.09	2.30	135	9.004	0.122	272.00	1.00	-0.82
WAVE	16/09/2022 23:02	0.18	3.60	104	9.063	0.163	247.00	1.06	-0.76
WAVE	16/09/2022 23:12	0.05	16.00	67	9.125	0.217	257.00	1.13	-0.70
WAVE	16/09/2022 23:22	0.07	16.00	319	9.194	0.252	262.00	1.19	-0.63
WAVE	16/09/2022 23:32	0.02	9.10	67	9.267	0.276	257.00	1.27	-0.55
WAVE	16/09/2022 23:42	0.02	9.10	151	9.325	0.271	259.00	1.33	-0.50
WAVE	16/09/2022 23:52	0.02	9.10	119	9.396	0.292	253.00	1.40	-0.42
WAVE	17/09/2022 00:02	0.02	10.70	211	9.48	0.259	251.00	1.48	-0.34
WAVE	17/09/2022 00:12	0.02	9.10	31	9.545	0.236	251.00	1.55	-0.28
WAVE	17/09/2022 00:22	0.12	2.40	112	9.621	0.259	259.00	1.62	-0.20
WAVE	17/09/2022 00:32	0.04	4.30	355	9.696	0.247	264.00	1.70	-0.12
WAVE	17/09/2022 00:42	0.07	2.70	347	9.777	0.281	255.00	1.78	-0.04
WAVE	17/09/2022 00:52	0.09	2.30	183	9.862	0.259	250.00	1.86	0.04
WAVE	17/09/2022 01:02	0.05	2.90	123	9.946	0.22	256.00	1.95	0.13
WAVE	17/09/2022 01:12	0.05	10.70	299	10.025	0.216	253.00	2.03	0.21
WAVE	17/09/2022 01:22	0.05	10.70	299	10.093	0.233	257.00	2.09	0.27
WAVE	17/09/2022 01:32	0.04	7.10	223	10.16	0.196	263.00	2.16	0.34
WAVE	17/09/2022 01:42	0.09	2.50	99	10.225	0.171	253.00	2.23	0.41
WAVE	17/09/2022 01:52	0.04	10.70	169	10.284	0.227	251.00	2.28	0.46
WAVE	17/09/2022 02:02	0.05	12.80	103	10.34	0.195	255.00	2.34	0.52
WAVE	17/09/2022 02:12	0.06	12.80	295	10.398	0.145	253.00	2.40	0.58
WAVE	17/09/2022 02:22	0.06	9.10	169	10.441	0.15	264.00	2.44	0.62
WAVE	17/09/2022 02:32	0.04	10.70	27	10.476	0.08	250.00	2.48	0.66
WAVE	17/09/2022 02:42	0.04	12.80	335	10.498	0.095	185.00	2.50	0.68
WAVE	17/09/2022 02:52	0.07	10.70	243	10.52	0.052	225.00	2.52	0.70
WAVE	17/09/2022 03:02	0.04	10.70	243	10.538	0.079	198.00	2.54	0.72
WAVE	17/09/2022 03:12	0.07	2.70	111	10.546	0.087	106.00	2.55	0.73
WAVE	17/09/2022 03:22	0.06	2.70	295	10.558	0.047	97.00	2.56	0.74
WAVE	17/09/2022 04:00	0.05	12.80	271	10.534	0.198	64.00	2.53	0.71
WAVE	17/09/2022 04:10	0.07	2.70	83	10.528	0.186	73.00	2.53	0.71
WAVE	17/09/2022 04:20	0.04	9.10	111	10.519	0.225	74.00	2.52	0.70
WAVE	17/09/2022 04:30	0.08	2.60	84	10.502	0.237	73.00	2.50	0.68
WAVE	17/09/2022 04:40	0.06	8.00	327	10.47	0.304	73.00	2.47	0.65
WAVE	17/09/2022 04:50	0.05	10.70	11	10.443	0.306	70.00	2.44	0.62
WAVE	17/09/2022 05:00	0.08	2.70	151	10.404	0.318	74.00	2.40	0.58
WAVE	17/09/2022 05:10	0.07	2.90	107	10.365	0.239	81.00	2.37	0.55
WAVE	17/09/2022 05:20	0.07	12.80	331	10.311	0.303	72.00	2.31	0.49
WAVE	17/09/2022 05:30	0.06	9.10	83	10.269	0.302	69.00	2.27	0.45
WAVE	17/09/2022 05:40	0.03	9.10	169	10.225	0.305	70.00	2.23	0.41
WAVE	17/09/2022 05:50	0.03	9.10	7	10.166	0.311	71.00	2.17	0.35
WAVE	17/09/2022 06:00	0.06	2.90	283	10.121	0.347	74.00	2.12	0.30
WAVE	17/09/2022 06:38	0.08	2.90	87	9.911	0.249	83.00	1.91	0.09
WAVE	17/09/2022 06:48	0.10	2.90	243	9.855	0.234	81.00	1.86	0.04
WAVE	17/09/2022 06:58	0.05	9.10	303	9.798	0.202	83.00	1.80	-0.02
WAVE	17/09/2022 07:08	0.05	16.00	299	9.734	0.174	47.00	1.73	-0.09
WAVE	17/09/2022 07:18	0.11	3.00	87	9.678	0.182	65.00	1.68	-0.14
WAVE	17/09/2022 07:28	0.07	2.60	323	9.631	0.152	61.00	1.63	-0.19
WAVE	17/09/2022 07:38	0.09	3.60	99	9.592	0.144	62.00	1.59	-0.23
WAVE	17/09/2022 07:48	0.08	2.90	111	9.551	0.125	61.00	1.55	-0.27
WAVE	17/09/2022 07:58	0.15	2.80	287	9.515	0.128	82.00	1.52	-0.30
WAVE	17/09/2022 08:08	0.19	2.70	307	9.487	0.144	77.00	1.49	-0.33
WAVE	17/09/2022 08:18	0.09	2.80	115	9.459	0.154	68.00	1.46	-0.36
WAVE	17/09/2022 08:28	0.14	3.20	115	9.448	0.147	57.00	1.45	-0.37
WAVE	17/09/2022 08:38	0.18	3.20	105	9.443	0.176	60.00	1.44	-0.38
WAVE	17/09/2022 08:48	0.21	2.70	309	9.44	0.111	61.00	1.44	-0.38
WAVE	17/09/2022 08:58	0.16	2.80	122	9.44	0.042	57.00	1.44	-0.38
WAVE	17/09/2022 09:08	0.09	2.80	295	9.444	0.053	21.00	1.44	-0.38
WAVE	17/09/2022 09:18	0.07	2.60	107	9.452	0.043	7.00	1.45	-0.37
WAVE	17/09/2022 09:28	0.09	2.90	123	9.468	0.021	14.00	1.47	-0.35
WAVE	17/09/2022 09:38	0.16	2.80	270	9.493	0.019	94.00	1.49	-0.33
WAVE	17/09/2022 09:48	0.18	1.90	117	9.52	0.051	249.00	1.52	-0.30
WAVE	17/09/2022 09:58	0.08	2.90	79	9.541	0.038	274.00	1.54	-0.28
WAVE	17/09/2022 10:08	0.07	3.40	111	9.58	0.053	255.00	1.58	-0.24
WAVE	17/09/2022 10:18	0.16	2.50	81	9.617	0.078	283.00	1.62	-0.20

Name	Date Time	Significant Height(m)	Peak Time(sec)	Peak Direction (degree)	ADCP Depth(m)	Current Speed(m/s)	Current Direction (degree)	water level reference to CD	water level reference to 1.82 SHD
WAVE	17/09/2022 10:28	0.09	2.30	316	9.648	0.108	266.00	1.65	-0.17
WAVE	17/09/2022 10:38	0.07	2.80	95	9.68	0.076	247.00	1.68	-0.14
WAVE	17/09/2022 10:48	0.05	10.70	71	9.711	0.084	244.00	1.71	-0.11
WAVE	17/09/2022 11:27	0.02	10.70	4	9.869	0.106	282.00	1.87	0.05
WAVE	17/09/2022 11:37	0.08	2.40	109	9.928	0.112	269.00	1.93	0.11
WAVE	17/09/2022 11:47	0.19	2.80	114	9.969	0.127	277.00	1.97	0.15
WAVE	17/09/2022 11:57	0.08	2.70	167	10.028	0.174	262.00	2.03	0.21
WAVE	17/09/2022 12:07	0.17	2.70	273	10.083	0.168	269.00	2.08	0.26
WAVE	17/09/2022 12:17	0.06	3.80	105	10.152	0.182	270.00	2.15	0.33
WAVE	17/09/2022 12:27	0.17	2.80	120	10.212	0.202	271.00	2.21	0.39
WAVE	17/09/2022 12:37	0.25	3.00	120	10.28	0.241	267.00	2.28	0.46
WAVE	17/09/2022 12:47	0.04	16.00	170	10.339	0.212	252.00	2.34	0.52
WAVE	17/09/2022 12:57	0.14	3.00	125	10.393	0.223	253.00	2.39	0.57
WAVE	17/09/2022 13:07	0.29	2.70	124	10.456	0.217	265.00	2.46	0.64
WAVE	17/09/2022 13:17	0.13	2.90	116	10.493	0.239	251.00	2.49	0.67
WAVE	17/09/2022 13:27	0.32	2.90	114	10.568	0.225	242.00	2.57	0.75
WAVE	17/09/2022 13:37	0.10	2.50	247	10.627	0.177	250.00	2.63	0.81
WAVE	17/09/2022 13:47	0.18	2.70	127	10.677	0.142	244.00	2.68	0.86
WAVE	17/09/2022 13:57	0.09	3.40	95	10.717	0.12	262.00	2.72	0.90
WAVE	17/09/2022 14:25	0.44	21.30	311	10.783	0.083	3.00	2.78	0.96
WAVE	17/09/2022 14:35	0.10	2.70	147	10.793	0.049	14.00	2.79	0.97
WAVE	17/09/2022 14:45	0.13	2.60	107	10.79	0.047	91.00	2.79	0.97
WAVE	17/09/2022 14:55	0.11	2.90	281	10.793	0.025	69.00	2.79	0.97
WAVE	17/09/2022 15:05	0.36	2.70	304	10.787	0.042	73.00	2.79	0.97
WAVE	17/09/2022 15:15	0.13	2.70	306	10.765	0.063	75.00	2.77	0.95
WAVE	17/09/2022 15:25	0.17	2.90	101	10.745	0.098	100.00	2.75	0.92
WAVE	17/09/2022 15:35	0.08	3.20	83	10.709	0.151	93.00	2.71	0.89
WAVE	17/09/2022 15:45	0.09	2.80	325	10.67	0.234	85.00	2.67	0.85
WAVE	17/09/2022 15:55	0.15	3.20	95	10.625	0.264	74.00	2.63	0.81
WAVE	17/09/2022 16:05	0.06	2.80	135	10.587	0.241	71.00	2.59	0.77
WAVE	17/09/2022 16:15	0.15	2.50	148	10.538	0.331	77.00	2.54	0.72
WAVE	17/09/2022 16:25	0.04	7.10	95	10.491	0.313	74.00	2.49	0.67
WAVE	17/09/2022 16:35	0.15	1.90	123	10.433	0.308	78.00	2.43	0.61
WAVE	17/09/2022 16:45	0.17	2.70	287	10.37	0.311	73.00	2.37	0.55
WAVE	17/09/2022 16:55	0.14	3.20	243	10.304	0.315	74.00	2.30	0.48
WAVE	17/09/2022 17:05	0.18	3.20	248	10.235	0.311	75.00	2.24	0.41
WAVE	17/09/2022 17:15	0.08	3.00	51	10.162	0.293	75.00	2.16	0.34
WAVE	17/09/2022 17:25	0.28	2.60	286	10.088	0.334	67.00	2.09	0.27
WAVE	17/09/2022 17:35	0.17	2.90	290	10.017	0.333	74.00	2.02	0.20
WAVE	17/09/2022 17:45	0.10	2.80	103	9.942	0.275	76.00	1.94	0.12
WAVE	17/09/2022 18:13	0.20	3.20	302	9.72	0.223	77.00	1.72	-0.10
WAVE	17/09/2022 18:23	0.05	3.40	169	9.644	0.213	82.00	1.64	-0.18
WAVE	17/09/2022 18:33	0.07	3.60	95	9.562	0.205	84.00	1.56	-0.26
WAVE	17/09/2022 18:43	0.16	2.60	197	9.489	0.199	90.00	1.49	-0.33
WAVE	17/09/2022 18:53	0.07	2.90	87	9.425	0.191	89.00	1.43	-0.39
WAVE	17/09/2022 19:03	0.06	5.80	67	9.354	0.166	93.00	1.35	-0.47
WAVE	17/09/2022 19:13	0.10	3.00	101	9.289	0.143	85.00	1.29	-0.53
WAVE	17/09/2022 19:23	0.09	2.80	295	9.211	0.116	80.00	1.21	-0.61
WAVE	17/09/2022 19:33	0.09	2.30	23	9.134	0.104	69.00	1.13	-0.69
WAVE	17/09/2022 19:43	0.15	2.40	218	9.084	0.086	68.00	1.08	-0.74
WAVE	17/09/2022 19:53	0.14	3.20	89	9.018	0.077	45.00	1.02	-0.80
WAVE	17/09/2022 20:03	0.07	3.80	87	8.969	0.041	45.00	0.97	-0.85
WAVE	17/09/2022 20:13	0.05	5.30	119	8.927	0.027	63.00	0.93	-0.89
WAVE	17/09/2022 20:23	0.07	2.50	161	8.891	0.016	3.00	0.89	-0.93
WAVE	17/09/2022 20:33	0.07	3.80	99	8.855	0.008	22.00	0.86	-0.97
WAVE	17/09/2022 20:43	0.08	2.40	235	8.822	0.037	48.00	0.82	-1.00
WAVE	17/09/2022 20:53	0.21	4.00	98	8.8	0.028	226.00	0.80	-1.02
WAVE	17/09/2022 21:03	0.06	3.00	359	8.785	0.032	86.00	0.79	-1.04
WAVE	17/09/2022 21:13	0.04	9.10	139	8.765	0.107	40.00	0.77	-1.06
WAVE	17/09/2022 21:23	0.14	4.30	115	8.754	0.156	50.00	0.75	-1.07
WAVE	17/09/2022 21:33	0.10	2.20	27	8.753	0.148	51.00	0.75	-1.07
WAVE	17/09/2022 21:43	0.07	2.70	87	8.748	0.146	59.00	0.75	-1.07
WAVE	17/09/2022 21:53	0.05	3.20	83	8.756	0.126	48.00	0.76	-1.06
WAVE	17/09/2022 22:03	0.06	9.10	135	8.758	0.127	48.00	0.76	-1.06

Name	Date Time	Significant Height(m)	Peak Time(sec)	Peak Direction (degree)	ADCP Depth(m)	Current Speed(m/s)	Current Direction (degree)	water level reference to CD	water level reference to 1.82 SHD
WAVE	17/09/2022 22:13	0.03	12.80	169	8.769	0.128	36.00	0.77	-1.05
WAVE	17/09/2022 22:51	0.10	10.70	63	8.84	0.076	20.00	0.84	-0.98
WAVE	17/09/2022 23:01	0.05	10.70	169	8.867	0.066	16.00	0.87	-0.95
WAVE	17/09/2022 23:11	0.05	3.40	219	8.897	0.054	316.00	0.90	-0.92
WAVE	17/09/2022 23:21	0.04	9.10	169	8.935	0.053	282.00	0.94	-0.89
WAVE	17/09/2022 23:31	0.05	5.30	95	8.987	0.096	271.00	0.99	-0.83
WAVE	17/09/2022 23:41	0.05	2.70	11	9.022	0.154	292.00	1.02	-0.80
WAVE	17/09/2022 23:51	0.04	9.10	147	9.086	0.185	252.00	1.09	-0.73
WAVE	18/09/2022 00:01	0.04	7.10	311	9.129	0.221	256.00	1.13	-0.69
WAVE	18/09/2022 00:11	0.09	9.10	139	9.181	0.279	256.00	1.18	-0.64
WAVE	18/09/2022 00:21	0.02	10.70	111	9.244	0.276	259.00	1.24	-0.58
WAVE	18/09/2022 00:31	0.07	2.90	83	9.308	0.244	253.00	1.31	-0.51
WAVE	18/09/2022 00:41	0.08	2.20	39	9.368	0.292	257.00	1.37	-0.45
WAVE	18/09/2022 00:51	0.03	12.80	169	9.441	0.283	251.00	1.44	-0.38
WAVE	18/09/2022 01:01	0.06	4.60	107	9.5	0.22	253.00	1.50	-0.32
WAVE	18/09/2022 01:11	0.06	3.20	119	9.564	0.247	257.00	1.56	-0.26
WAVE	18/09/2022 01:21	0.07	4.00	227	9.628	0.19	244.00	1.63	-0.19
WAVE	18/09/2022 01:31	0.04	21.30	3	9.691	0.177	247.00	1.69	-0.13
WAVE	18/09/2022 01:41	0.02	10.70	259	9.744	0.178	248.00	1.74	-0.08
WAVE	18/09/2022 01:51	0.04	3.40	171	9.807	0.173	244.00	1.81	-0.01
WAVE	18/09/2022 02:01	0.03	21.30	347	9.86	0.158	250.00	1.86	0.04
WAVE	18/09/2022 02:11	0.07	2.40	211	9.909	0.121	259.00	1.91	0.09
WAVE	18/09/2022 02:21	0.06	8.00	169	9.962	0.127	274.00	1.96	0.14
WAVE	18/09/2022 02:31	0.07	3.60	190	10.006	0.11	268.00	2.01	0.19
WAVE	18/09/2022 02:41	0.06	9.10	35	10.043	0.071	269.00	2.04	0.22
WAVE	18/09/2022 02:51	0.05	2.80	11	10.09	0.07	256.00	2.09	0.27
WAVE	18/09/2022 03:01	0.02	10.70	7	10.131	0.08	268.00	2.13	0.31
WAVE	18/09/2022 03:11	0.03	12.80	271	10.162	0.053	279.00	2.16	0.34
WAVE	18/09/2022 03:21	0.06	4.90	169	10.184	0.046	287.00	2.18	0.36
WAVE	18/09/2022 03:31	0.04	10.70	167	10.202	0.015	318.00	2.20	0.38
WAVE	18/09/2022 03:41	0.05	10.70	95	10.214	0.009	95.00	2.21	0.39
WAVE	18/09/2022 04:10	0.05	10.70	35	10.249	0.057	332.00	2.25	0.43
WAVE	18/09/2022 04:20	0.05	4.90	167	10.271	0.063	92.00	2.27	0.45
WAVE	18/09/2022 04:30	0.02	10.70	291	10.274	0.093	89.00	2.27	0.45
WAVE	18/09/2022 04:40	0.06	3.40	143	10.272	0.101	103.00	2.27	0.45
WAVE	18/09/2022 04:50	0.05	12.80	169	10.267	0.092	89.00	2.27	0.45
WAVE	18/09/2022 05:00	0.07	9.10	87	10.265	0.115	94.00	2.27	0.45
WAVE	18/09/2022 05:10	0.04	8.00	71	10.252	0.144	74.00	2.25	0.43
WAVE	18/09/2022 05:20	0.05	8.00	359	10.246	0.128	67.00	2.25	0.43
WAVE	18/09/2022 05:30	0.05	12.80	123	10.223	0.108	54.00	2.22	0.40
WAVE	18/09/2022 05:40	0.13	2.10	39	10.211	0.118	59.00	2.21	0.39
WAVE	18/09/2022 05:50	0.12	2.90	189	10.195	0.15	62.00	2.20	0.38
WAVE	18/09/2022 06:18	0.09	2.90	24	10.131	0.197	84.00	2.13	0.31
WAVE	18/09/2022 06:28	0.03	9.10	355	10.115	0.203	77.00	2.12	0.30
WAVE	18/09/2022 06:38	0.06	10.70	35	10.098	0.225	77.00	2.10	0.28
WAVE	18/09/2022 06:48	0.04	9.10	7	10.078	0.226	78.00	2.08	0.26
WAVE	18/09/2022 06:58	0.08	2.80	118	10.052	0.223	73.00	2.05	0.23
WAVE	18/09/2022 07:08	0.10	3.00	102	10.031	0.223	77.00	2.03	0.21
WAVE	18/09/2022 07:18	0.06	9.10	169	10.006	0.197	77.00	2.01	0.19
WAVE	18/09/2022 07:28	0.07	3.60	111	9.975	0.209	70.00	1.98	0.16
WAVE	18/09/2022 08:06	0.08	8.00	263	9.889	0.15	86.00	1.89	0.07
WAVE	18/09/2022 08:16	0.16	3.00	285	9.884	0.154	81.00	1.88	0.06
WAVE	18/09/2022 08:26	0.05	16.00	87	9.88	0.143	76.00	1.88	0.06
WAVE	18/09/2022 08:36	0.24	3.20	88	9.882	0.117	79.00	1.88	0.06
WAVE	18/09/2022 08:46	0.20	2.00	108	9.871	0.142	74.00	1.87	0.05
WAVE	18/09/2022 08:56	0.14	2.70	307	9.834	0.149	75.00	1.83	0.01
WAVE	18/09/2022 09:06	0.19	3.20	91	9.804	0.187	72.00	1.80	-0.02
WAVE	18/09/2022 09:16	0.10	2.10	107	9.825	0.186	74.00	1.83	0.00
WAVE	18/09/2022 09:55	0.14	2.90	100	9.795	0.188	89.00	1.80	-0.03
WAVE	18/09/2022 10:05	0.13	2.50	280	9.798	0.181	80.00	1.80	-0.02
WAVE	18/09/2022 10:15	0.10	4.30	91	9.783	0.205	82.00	1.78	-0.04
WAVE	18/09/2022 10:25	0.07	2.60	84	9.782	0.148	71.00	1.78	-0.04
WAVE	18/09/2022 10:35	0.06	9.10	3	9.79	0.119	72.00	1.79	-0.03
WAVE	18/09/2022 10:45	0.05	9.10	67	9.808	0.117	81.00	1.81	-0.01

Name	Date Time	Significant Height(m)	Peak Time(sec)	Peak Direction (degree)	ADCP Depth(m)	Current Speed(m/s)	Current Direction (degree)	water level reference to CD	water level reference to 1.82 SHD
WAVE	18/09/2022 10:55	0.07	2.50	107	9.804	0.084	72.00	1.80	-0.02
WAVE	18/09/2022 11:05	0.08	2.10	51	9.83	0.065	54.00	1.83	0.01
WAVE	18/09/2022 11:15	0.08	2.70	75	9.841	0.075	38.00	1.84	0.02
WAVE	18/09/2022 11:25	0.07	2.40	351	9.849	0.055	49.00	1.85	0.03
WAVE	18/09/2022 11:35	0.15	2.50	232	9.868	0.088	356.00	1.87	0.05
WAVE	18/09/2022 12:08	0.27	10.70	355	9.981	0.033	56.00	1.98	0.16
WAVE	18/09/2022 12:18	0.17	3.20	130	10.014	0.087	305.00	2.01	0.19
WAVE	18/09/2022 12:28	0.09	2.60	274	10.066	0.061	250.00	2.07	0.25
WAVE	18/09/2022 12:38	0.05	10.70	84	10.098	0.078	264.00	2.10	0.28
WAVE	18/09/2022 12:48	0.10	2.30	284	10.129	0.054	326.00	2.13	0.31
WAVE	18/09/2022 12:58	0.08	2.70	166	10.181	0.05	276.00	2.18	0.36
WAVE	18/09/2022 13:08	0.06	8.00	256	10.216	0.062	236.00	2.22	0.40
WAVE	18/09/2022 13:18	0.06	2.90	92	10.265	0.076	235.00	2.27	0.45
WAVE	18/09/2022 13:28	0.11	2.40	140	10.308	0.048	267.00	2.31	0.49
WAVE	18/09/2022 13:38	0.30	2.80	313	10.356	0.086	252.00	2.36	0.54
WAVE	18/09/2022 13:48	0.08	2.20	263	10.404	0.057	244.00	2.40	0.58
WAVE	18/09/2022 13:58	0.11	10.70	139	10.45	0.054	196.00	2.45	0.63
WAVE	18/09/2022 14:08	0.07	3.20	103	10.49	0.089	230.00	2.49	0.67
WAVE	18/09/2022 14:18	0.21	2.70	151	10.521	0.082	211.00	2.52	0.70
WAVE	18/09/2022 14:51	0.05	9.10	303	10.604	0.304	60.00	2.60	0.78
WAVE	18/09/2022 15:01	0.13	2.80	305	10.623	0.087	129.00	2.62	0.80
WAVE	18/09/2022 15:11	0.07	2.80	115	10.64	0.082	126.00	2.64	0.82
WAVE	18/09/2022 15:21	0.14	2.90	135	10.636	0.115	85.00	2.64	0.82
WAVE	18/09/2022 15:54	0.05	12.80	191	10.57	0.457	62.00	2.57	0.75
WAVE	18/09/2022 16:04	0.28	1.80	146	10.533	0.284	84.00	2.53	0.71
WAVE	18/09/2022 16:14	0.14	2.90	52	10.513	0.282	80.00	2.51	0.69
WAVE	18/09/2022 16:24	0.09	2.90	93	10.477	0.305	72.00	2.48	0.66
WAVE	18/09/2022 16:34	0.06	2.40	103	10.447	0.271	76.00	2.45	0.63
WAVE	18/09/2022 16:44	0.24	3.40	86	10.412	0.314	78.00	2.41	0.59
WAVE	18/09/2022 16:54	0.16	2.70	79	10.366	0.32	76.00	2.37	0.55
WAVE	18/09/2022 17:04	0.09	2.50	47	10.317	0.311	77.00	2.32	0.50
WAVE	18/09/2022 17:14	0.08	3.60	87	10.266	0.282	78.00	2.27	0.45
WAVE	18/09/2022 17:24	0.22	2.90	77	10.221	0.271	73.00	2.22	0.40
WAVE	18/09/2022 17:58	0.20	12.80	291	10.038	0.25	82.00	2.04	0.22
WAVE	18/09/2022 18:08	0.10	2.50	187	9.981	0.268	70.00	1.98	0.16
WAVE	18/09/2022 18:18	0.05	12.80	27	9.923	0.273	63.00	1.92	0.10
WAVE	18/09/2022 18:28	0.13	3.40	106	9.863	0.271	70.00	1.86	0.04
WAVE	18/09/2022 18:38	0.14	3.40	75	9.802	0.278	64.00	1.80	-0.02
WAVE	18/09/2022 18:48	0.08	2.30	131	9.745	0.249	70.00	1.75	-0.08
WAVE	18/09/2022 18:58	0.08	2.90	103	9.684	0.297	68.00	1.68	-0.14
WAVE	18/09/2022 19:08	0.11	2.90	293	9.623	0.323	69.00	1.62	-0.20
WAVE	18/09/2022 19:41	0.08	3.20	65	9.412	0.37	60.00	1.41	-0.41
WAVE	18/09/2022 19:51	0.14	1.90	204	9.35	0.205	67.00	1.35	-0.47
WAVE	18/09/2022 20:01	0.07	2.70	211	9.302	0.166	68.00	1.30	-0.52
WAVE	18/09/2022 20:11	0.06	2.90	89	9.246	0.172	71.00	1.25	-0.57
WAVE	18/09/2022 20:21	0.07	3.20	103	9.19	0.202	71.00	1.19	-0.63
WAVE	18/09/2022 20:31	0.06	3.00	169	9.14	0.18	72.00	1.14	-0.68
WAVE	18/09/2022 20:41	0.07	7.10	295	9.094	0.179	65.00	1.09	-0.73
WAVE	18/09/2022 20:51	0.06	2.60	83	9.038	0.147	55.00	1.04	-0.78
WAVE	18/09/2022 21:01	0.06	9.10	135	8.998	0.119	70.00	1.00	-0.82
WAVE	18/09/2022 21:11	0.09	2.50	95	8.964	0.138	72.00	0.96	-0.86
WAVE	18/09/2022 21:21	0.09	3.80	111	8.939	0.159	69.00	0.94	-0.88
WAVE	18/09/2022 21:31	0.03	12.80	11	8.912	0.161	70.00	0.91	-0.91
WAVE	18/09/2022 21:41	0.06	3.80	25	8.89	0.102	65.00	0.89	-0.93
WAVE	18/09/2022 21:51	0.10	1.90	167	8.875	0.146	68.00	0.88	-0.95
WAVE	18/09/2022 22:24	0.20	9.10	151	8.829	0.173	50.00	0.83	-0.99
WAVE	18/09/2022 22:34	0.05	9.10	163	8.825	0.129	58.00	0.82	-1.00
WAVE	18/09/2022 22:44	0.06	4.90	91	8.827	0.126	56.00	0.83	-0.99
WAVE	18/09/2022 22:54	0.07	2.30	83	8.832	0.119	52.00	0.83	-0.99
WAVE	18/09/2022 23:04	0.01	9.10	267	8.831	0.097	42.00	0.83	-0.99
WAVE	18/09/2022 23:14	0.05	4.60	355	8.832	0.09	49.00	0.83	-0.99
WAVE	18/09/2022 23:24	0.06	2.70	181	8.843	0.068	46.00	0.84	-0.98
WAVE	18/09/2022 23:34	0.18	2.60	212	8.857	0.024	27.00	0.86	-0.96
WAVE	18/09/2022 23:44	0.13	2.80	78	8.879	0.018	308.00	0.88	-0.94

Name	Date Time	Significant Height(m)	Peak Time(sec)	Peak Direction (degree)	ADCP Depth(m)	Current Speed(m/s)	Current Direction (degree)	water level reference to CD	water level reference to 1.82 SHD
WAVE	18/09/2022 23:54	0.12	2.70	106	8.901	0.025	286.00	0.90	-0.92
WAVE	19/09/2022 00:04	0.11	2.70	97	8.924	0.034	283.00	0.92	-0.90
WAVE	19/09/2022 00:14	0.05	21.30	87	8.943	0.042	281.00	0.94	-0.88
WAVE	19/09/2022 00:24	0.07	2.30	11	8.978	0.059	273.00	0.98	-0.84
WAVE	19/09/2022 00:34	0.06	9.10	63	9.012	0.063	263.00	1.01	-0.81
WAVE	19/09/2022 00:44	0.05	21.30	103	9.051	0.098	261.00	1.05	-0.77
WAVE	19/09/2022 00:54	0.05	8.00	207	9.097	0.136	253.00	1.10	-0.72
WAVE	19/09/2022 01:04	0.09	2.90	99	9.136	0.168	258.00	1.14	-0.68
WAVE	19/09/2022 01:14	0.06	9.10	169	9.189	0.186	253.00	1.19	-0.63
WAVE	19/09/2022 01:24	0.07	2.90	91	9.237	0.196	249.00	1.24	-0.58
WAVE	19/09/2022 01:34	0.05	21.30	295	9.286	0.191	253.00	1.29	-0.53
WAVE	19/09/2022 01:44	0.04	9.10	23	9.343	0.211	257.00	1.34	-0.48
WAVE	19/09/2022 01:54	0.04	21.30	87	9.399	0.201	255.00	1.40	-0.42
WAVE	19/09/2022 02:04	0.05	9.10	307	9.437	0.22	268.00	1.44	-0.38
WAVE	19/09/2022 02:14	0.05	16.00	91	9.482	0.182	274.00	1.48	-0.34
WAVE	19/09/2022 02:24	0.07	8.00	335	9.527	0.197	271.00	1.53	-0.29
WAVE	19/09/2022 02:34	0.10	2.30	81	9.567	0.203	268.00	1.57	-0.25
WAVE	19/09/2022 02:44	0.07	2.50	263	9.604	0.155	269.00	1.60	-0.22
WAVE	19/09/2022 02:54	0.04	9.10	251	9.639	0.124	272.00	1.64	-0.18
WAVE	19/09/2022 03:04	0.08	2.50	169	9.677	0.143	273.00	1.68	-0.14
WAVE	19/09/2022 03:14	0.11	2.10	187	9.707	0.142	263.00	1.71	-0.11
WAVE	19/09/2022 03:24	0.14	2.10	307	9.735	0.118	284.00	1.74	-0.09
WAVE	19/09/2022 03:34	0.09	2.20	311	9.757	0.128	275.00	1.76	-0.06
WAVE	19/09/2022 04:07	0.04	9.10	147	9.821	0.041	14.00	1.82	0.00
WAVE	19/09/2022 04:17	0.08	3.60	221	9.835	0.059	281.00	1.84	0.02
WAVE	19/09/2022 04:27	0.07	2.20	195	9.86	0.043	218.00	1.86	0.04
WAVE	19/09/2022 05:01	0.04	9.10	315	9.906	0.177	72.00	1.91	0.09
WAVE	19/09/2022 05:11	0.06	10.70	169	9.913	0.035	82.00	1.91	0.09
WAVE	19/09/2022 05:21	0.05	12.80	215	9.923	0.056	76.00	1.92	0.10
WAVE	19/09/2022 05:54	0.04	9.10	115	9.938	0.132	77.00	1.94	0.12
WAVE	19/09/2022 06:04	0.03	12.80	247	9.946	0.074	93.00	1.95	0.13
WAVE	19/09/2022 06:14	0.06	10.70	283	9.947	0.069	85.00	1.95	0.13
WAVE	19/09/2022 06:24	0.07	16.00	255	9.949	0.118	85.00	1.95	0.13
WAVE	19/09/2022 06:34	0.06	21.30	135	9.949	0.072	98.00	1.95	0.13
WAVE	19/09/2022 07:07	0.08	10.70	211	9.956	0.09	86.00	1.96	0.14
WAVE	19/09/2022 07:17	0.14	2.70	304	9.961	0.048	99.00	1.96	0.14
WAVE	19/09/2022 07:27	0.11	3.00	256	9.952	0.069	63.00	1.95	0.13
WAVE	19/09/2022 07:37	0.13	3.00	254	9.944	0.076	52.00	1.94	0.12
WAVE	19/09/2022 08:11	0.16	3.00	75	9.94	0.08	59.00	1.94	0.12
WAVE	19/09/2022 08:21	0.06	12.80	239	9.934	0.06	69.00	1.93	0.11
WAVE	19/09/2022 08:31	0.13	2.90	111	9.932	0.078	65.00	1.93	0.11
WAVE	19/09/2022 08:41	0.07	2.60	95	9.93	0.077	67.00	1.93	0.11
WAVE	19/09/2022 08:51	0.07	3.80	94	9.925	0.086	56.00	1.93	0.11
WAVE	19/09/2022 09:24	0.10	2.70	95	9.903	0.105	44.00	1.90	0.08
WAVE	19/09/2022 09:34	0.13	2.50	91	9.903	0.135	72.00	1.90	0.08
WAVE	19/09/2022 09:44	0.07	2.60	267	9.907	0.152	73.00	1.91	0.09
WAVE	19/09/2022 09:54	0.25	3.00	298	9.901	0.151	70.00	1.90	0.08
WAVE	19/09/2022 10:27	0.13	4.60	151	9.901	0.159	48.00	1.90	0.08
WAVE	19/09/2022 10:37	0.09	2.80	105	9.909	0.102	72.00	1.91	0.09
WAVE	19/09/2022 10:47	0.19	2.60	133	9.911	0.118	73.00	1.91	0.09
WAVE	19/09/2022 10:57	0.20	3.40	98	9.919	0.084	59.00	1.92	0.10
WAVE	19/09/2022 11:30	0.25	9.10	186	9.951	0.11	51.00	1.95	0.13
WAVE	19/09/2022 11:40	0.06	3.20	95	9.969	0.034	94.00	1.97	0.15
WAVE	19/09/2022 12:00	0.13	2.40	238	10.001	0.024	121.00	2.00	0.18
WAVE	19/09/2022 12:34	0.29	9.10	170	10.059	0.06	54.00	2.06	0.24
WAVE	19/09/2022 12:44	0.10	2.70	116	10.091	0.023	160.00	2.09	0.27
WAVE	19/09/2022 12:54	0.14	3.20	95	10.113	0.059	13.00	2.11	0.29
WAVE	19/09/2022 13:04	0.18	2.30	267	10.144	0.092	204.00	2.14	0.32
WAVE	19/09/2022 13:14	0.05	2.60	127	10.16	0.077	202.00	2.16	0.34
WAVE	19/09/2022 13:24	0.03	10.70	27	10.187	0.049	239.00	2.19	0.37
WAVE	19/09/2022 13:34	0.06	12.80	199	10.206	0.034	259.00	2.21	0.39
WAVE	19/09/2022 13:44	0.07	3.20	120	10.231	0.077	226.00	2.23	0.41
WAVE	19/09/2022 13:54	0.03	9.10	331	10.247	0.02	257.00	2.25	0.43
WAVE	19/09/2022 14:04	0.18	2.80	302	10.268	0.056	190.00	2.27	0.45

Name	Date Time	Significant Height(m)	Peak Time(sec)	Peak Direction (degree)	ADCP Depth(m)	Current Speed(m/s)	Current Direction (degree)	water level reference to CD	water level reference to 1.82 SHD
WAVE	19/09/2022 14:14	0.07	2.90	111	10.288	0.008	263.00	2.29	0.47
WAVE	19/09/2022 14:24	0.18	2.40	75	10.296	0.017	203.00	2.30	0.48
WAVE	19/09/2022 14:34	0.11	2.80	95	10.322	0.025	227.00	2.32	0.50
WAVE	19/09/2022 14:44	0.10	2.60	139	10.343	0.019	211.00	2.34	0.52
WAVE	19/09/2022 14:54	0.07	3.60	99	10.346	0.007	157.00	2.35	0.53
WAVE	19/09/2022 15:27	0.25	9.10	279	10.39	0.189	62.00	2.39	0.57
WAVE	19/09/2022 15:37	0.13	2.20	123	10.395	0.08	90.00	2.40	0.58
WAVE	19/09/2022 15:47	0.11	2.70	100	10.391	0.064	74.00	2.39	0.57
WAVE	19/09/2022 15:57	0.05	4.30	87	10.383	0.089	79.00	2.38	0.56
WAVE	19/09/2022 16:07	0.11	2.60	129	10.384	0.112	81.00	2.38	0.56
WAVE	19/09/2022 16:40	0.03	9.10	169	10.351	0.242	67.00	2.35	0.53
WAVE	19/09/2022 16:50	0.13	2.90	97	10.33	0.15	91.00	2.33	0.51
WAVE	19/09/2022 17:00	0.12	2.70	311	10.311	0.17	78.00	2.31	0.49
WAVE	19/09/2022 17:33	0.03	10.70	167	10.253	0.267	78.00	2.25	0.43
WAVE	19/09/2022 17:43	0.07	3.20	127	10.227	0.166	83.00	2.23	0.41
WAVE	19/09/2022 17:53	0.21	3.00	305	10.198	0.168	72.00	2.20	0.38
WAVE	19/09/2022 18:03	0.10	2.10	87	10.168	0.186	85.00	2.17	0.35
WAVE	19/09/2022 18:37	0.16	10.70	155	10.069	0.242	62.00	2.07	0.25
WAVE	19/09/2022 18:47	0.08	3.00	63	10.038	0.172	87.00	2.04	0.22
WAVE	19/09/2022 18:57	0.11	3.80	89	10.012	0.174	68.00	2.01	0.19
WAVE	19/09/2022 19:07	0.06	4.30	147	9.981	0.167	76.00	1.98	0.16
WAVE	19/09/2022 19:17	0.07	2.80	109	9.929	0.196	65.00	1.93	0.11
WAVE	19/09/2022 19:27	0.08	3.40	83	9.892	0.24	82.00	1.89	0.07
WAVE	19/09/2022 19:37	0.20	2.50	225	9.856	0.26	66.00	1.86	0.04
WAVE	19/09/2022 19:47	0.08	2.80	119	9.804	0.272	65.00	1.80	-0.02
WAVE	19/09/2022 20:10	0.07	2.90	31	9.703	0.307	63.00	1.70	-0.12
WAVE	19/09/2022 20:20	0.07	3.40	107	9.688	0.289	68.00	1.69	-0.13
WAVE	19/09/2022 20:30	0.07	2.90	94	9.634	0.295	69.00	1.63	-0.19
WAVE	19/09/2022 20:40	0.04	9.10	139	9.597	0.318	63.00	1.60	-0.22
WAVE	19/09/2022 21:13	0.06	16.00	343	9.456	0.271	62.00	1.46	-0.36
WAVE	19/09/2022 21:23	0.06	2.70	99	9.414	0.287	61.00	1.41	-0.41
WAVE	19/09/2022 21:33	0.10	1.80	169	9.371	0.273	70.00	1.37	-0.45
WAVE	19/09/2022 21:43	0.05	2.90	99	9.334	0.219	64.00	1.33	-0.49
WAVE	19/09/2022 21:53	0.09	2.40	96	9.293	0.22	74.00	1.29	-0.53
WAVE	19/09/2022 22:03	0.08	2.60	122	9.261	0.203	78.00	1.26	-0.56
WAVE	19/09/2022 22:37	0.08	12.80	31	9.151	0.249	82.00	1.15	-0.67
WAVE	19/09/2022 22:47	0.11	2.60	98	9.115	0.174	82.00	1.12	-0.71
WAVE	19/09/2022 22:57	0.10	2.60	283	9.09	0.18	83.00	1.09	-0.73
WAVE	19/09/2022 23:07	0.07	2.50	343	9.078	0.15	83.00	1.08	-0.74
WAVE	19/09/2022 23:17	0.05	12.80	299	9.034	0.128	69.00	1.03	-0.79
WAVE	19/09/2022 23:27	0.07	9.10	67	9.024	0.143	74.00	1.02	-0.80
WAVE	19/09/2022 23:37	0.06	10.70	51	9.01	0.153	67.00	1.01	-0.81
WAVE	20/09/2022 00:10	0.08	12.80	327	8.973	0.125	49.00	0.97	-0.85
WAVE	20/09/2022 00:20	0.05	21.30	135	8.964	0.082	67.00	0.96	-0.86
WAVE	20/09/2022 00:30	0.06	10.70	83	8.969	0.058	67.00	0.97	-0.85
WAVE	20/09/2022 00:40	0.06	3.80	112	8.974	0.028	113.00	0.97	-0.85
WAVE	20/09/2022 00:50	0.09	2.40	252	8.964	0.034	274.00	0.96	-0.86
WAVE	20/09/2022 01:00	0.06	21.30	170	8.97	0.05	266.00	0.97	-0.85
WAVE	20/09/2022 01:10	0.03	9.10	91	8.986	0.077	265.00	0.99	-0.83
WAVE	20/09/2022 01:20	0.07	21.30	170	9.013	0.113	261.00	1.01	-0.81
WAVE	20/09/2022 01:30	0.07	2.30	48	9.033	0.128	264.00	1.03	-0.79
WAVE	20/09/2022 01:40	0.05	21.30	170	9.064	0.138	252.00	1.06	-0.76
WAVE	20/09/2022 01:50	0.04	8.00	7	9.09	0.175	243.00	1.09	-0.73
WAVE	20/09/2022 02:00	0.05	10.70	335	9.122	0.207	253.00	1.12	-0.70
WAVE	20/09/2022 02:10	0.05	9.10	131	9.15	0.208	256.00	1.15	-0.67
WAVE	20/09/2022 02:20	0.07	2.40	159	9.197	0.207	252.00	1.20	-0.62
WAVE	20/09/2022 02:30	0.07	7.10	151	9.219	0.208	258.00	1.22	-0.60
WAVE	20/09/2022 02:40	0.04	9.10	351	9.262	0.237	259.00	1.26	-0.56
WAVE	20/09/2022 02:50	0.06	5.80	63	9.306	0.222	252.00	1.31	-0.51
WAVE	20/09/2022 03:00	0.04	5.80	35	9.34	0.222	263.00	1.34	-0.48
WAVE	20/09/2022 03:10	0.04	7.10	47	9.384	0.219	264.00	1.38	-0.44
WAVE	20/09/2022 03:20	0.06	2.50	183	9.419	0.196	254.00	1.42	-0.40
WAVE	20/09/2022 03:30	0.05	2.70	151	9.451	0.19	253.00	1.45	-0.37
WAVE	20/09/2022 03:40	0.03	9.10	169	9.49	0.177	261.00	1.49	-0.33

Name	Date Time	Significant Height(m)	Peak Time(sec)	Peak Direction (degree)	ADCP Depth(m)	Current Speed(m/s)	Current Direction (degree)	water level reference to CD	water level reference to 1.82 SHD
WAVE	20/09/2022 03:50	0.05	2.90	15	9.517	0.227	258.00	1.52	-0.30
WAVE	20/09/2022 04:00	0.04	9.10	169	9.541	0.171	249.00	1.54	-0.28
WAVE	20/09/2022 04:10	0.09	2.20	221	9.579	0.167	250.00	1.58	-0.24
WAVE	20/09/2022 04:20	0.06	10.70	47	9.612	0.147	247.00	1.61	-0.21
WAVE	20/09/2022 04:30	0.08	2.40	67	9.63	0.134	246.00	1.63	-0.19
WAVE	20/09/2022 04:40	0.05	2.60	271	9.657	0.131	241.00	1.66	-0.16
WAVE	20/09/2022 04:50	0.04	16.00	223	9.682	0.121	247.00	1.68	-0.14
WAVE	20/09/2022 05:00	0.04	3.60	279	9.708	0.116	239.00	1.71	-0.11
WAVE	20/09/2022 05:10	0.05	10.70	169	9.724	0.13	252.00	1.72	-0.10
WAVE	20/09/2022 05:20	0.05	16.00	343	9.757	0.069	230.00	1.76	-0.06
WAVE	20/09/2022 05:30	0.06	12.80	169	9.77	0.083	254.00	1.77	-0.05
WAVE	20/09/2022 05:40	0.04	12.80	47	9.78	0.055	263.00	1.78	-0.04
WAVE	20/09/2022 05:50	0.03	6.40	171	9.812	0.075	278.00	1.81	-0.01
WAVE	20/09/2022 06:00	0.02	21.30	63	9.839	0.071	264.00	1.84	0.02
WAVE	20/09/2022 06:10	0.04	3.60	299	9.859	0.052	270.00	1.86	0.04
WAVE	20/09/2022 06:43	0.02	9.10	169	9.92	0.004	263.00	1.92	0.10
WAVE	20/09/2022 06:53	0.07	1.90	263	9.941	0.031	176.00	1.94	0.12
WAVE	20/09/2022 07:03	0.18	2.70	287	9.962	0.011	162.00	1.96	0.14
WAVE	20/09/2022 07:13	0.03	9.10	19	9.984	0.021	194.00	1.98	0.16
WAVE	20/09/2022 07:23	0.10	2.40	90	10.003	0.019	245.00	2.00	0.18
WAVE	20/09/2022 07:57	0.20	2.20	243	10.086	0.056	156.00	2.09	0.27
WAVE	20/09/2022 08:07	0.07	2.50	171	10.082	0.021	12.00	2.08	0.26
WAVE	20/09/2022 08:17	0.17	2.50	134	10.11	0.029	358.00	2.11	0.29
WAVE	20/09/2022 08:50	0.25	2.80	319	10.157	0.122	106.00	2.16	0.34
WAVE	20/09/2022 09:00	0.06	5.30	336	10.151	0.015	28.00	2.15	0.33
WAVE	20/09/2022 09:33	0.29	2.70	324	10.164	0.151	59.00	2.16	0.34
WAVE	20/09/2022 09:43	0.18	3.60	130	10.163	0.047	80.00	2.16	0.34
WAVE	20/09/2022 09:53	0.18	2.70	317	10.165	0.085	52.00	2.17	0.34
WAVE	20/09/2022 10:26	0.17	3.40	111	10.155	0.196	78.00	2.16	0.33
WAVE	20/09/2022 10:36	0.04	12.80	7	10.14	0.152	72.00	2.14	0.32
WAVE	20/09/2022 10:46	0.10	2.60	99	10.129	0.181	67.00	2.13	0.31
WAVE	20/09/2022 10:56	0.15	2.30	309	10.115	0.177	63.00	2.12	0.30
WAVE	20/09/2022 11:06	0.15	2.90	109	10.111	0.185	73.00	2.11	0.29
WAVE	20/09/2022 11:40	0.04	12.80	169	10.04	0.248	65.00	2.04	0.22
WAVE	20/09/2022 11:50	0.10	2.60	90	10.031	0.222	62.00	2.03	0.21
WAVE	20/09/2022 12:00	0.07	4.30	111	10.02	0.222	68.00	2.02	0.20
WAVE	20/09/2022 12:10	0.14	2.90	108	10.004	0.199	67.00	2.00	0.18
WAVE	20/09/2022 12:20	0.10	4.00	93	9.998	0.202	63.00	2.00	0.18
WAVE	20/09/2022 12:30	0.09	2.80	101	9.989	0.2	61.00	1.99	0.17
WAVE	20/09/2022 13:03	0.19	9.10	169	10	0.088	72.00	2.00	0.18
WAVE	20/09/2022 13:13	0.21	2.70	117	9.99	0.095	42.00	1.99	0.17
WAVE	20/09/2022 13:23	0.25	3.00	111	10	0.053	64.00	2.00	0.18
WAVE	20/09/2022 13:33	0.10	2.70	107	10.009	0.082	78.00	2.01	0.19
WAVE	20/09/2022 13:43	0.13	2.80	87	10.011	0.079	88.00	2.01	0.19
WAVE	20/09/2022 13:53	0.13	2.80	291	10.019	0.057	69.00	2.02	0.20
WAVE	20/09/2022 14:03	0.07	4.90	91	10.023	0.054	79.00	2.02	0.20
WAVE	20/09/2022 14:13	0.16	3.40	128	10.035	0.052	66.00	2.04	0.22
WAVE	20/09/2022 14:23	0.05	7.10	287	10.038	0.05	37.00	2.04	0.22
WAVE	20/09/2022 14:33	0.05	4.00	151	10.042	0.059	69.00	2.04	0.22
WAVE	20/09/2022 14:43	0.05	12.80	169	10.057	0.066	51.00	2.06	0.24
WAVE	20/09/2022 14:53	0.10	2.10	251	10.05	0.092	58.00	2.05	0.23
WAVE	20/09/2022 15:03	0.03	10.70	291	10.065	0.102	49.00	2.07	0.24
WAVE	20/09/2022 15:13	0.15	2.80	103	10.075	0.094	56.00	2.08	0.25
WAVE	20/09/2022 15:46	0.12	9.10	99	10.097	0.082	56.00	2.10	0.28
WAVE	20/09/2022 15:56	0.10	3.80	95	10.115	0.094	53.00	2.12	0.30
WAVE	20/09/2022 16:06	0.07	2.90	95	10.122	0.073	52.00	2.12	0.30
WAVE	20/09/2022 16:16	0.09	2.10	315	10.129	0.066	84.00	2.13	0.31
WAVE	20/09/2022 16:26	0.06	3.00	103	10.134	0.081	59.00	2.13	0.31
WAVE	20/09/2022 16:59	0.15	2.30	63	10.152	0.129	62.00	2.15	0.33
WAVE	20/09/2022 17:09	0.13	2.40	307	10.172	0.112	79.00	2.17	0.35
WAVE	20/09/2022 17:19	0.36	3.40	279	10.141	0.093	67.00	2.14	0.32
WAVE	20/09/2022 17:53	0.26	12.80	170	10.141	0.119	66.00	2.14	0.32
WAVE	20/09/2022 18:26	0.23	3.80	101	10.131	0.084	66.00	2.13	0.31
WAVE	20/09/2022 18:36	0.07	3.60	51	10.129	0.123	58.00	2.13	0.31

Name	Date Time	Significant Height(m)	Peak Time(sec)	Peak Direction (degree)	ADCP Depth(m)	Current Speed(m/s)	Current Direction (degree)	water level reference to CD	water level reference to 1.82 SHD
WAVE	20/09/2022 18:46	0.11	2.50	93	10.121	0.141	69.00	2.12	0.30
WAVE	20/09/2022 19:19	0.18	9.10	169	10.064	0.157	39.00	2.06	0.24
WAVE	20/09/2022 19:29	0.08	2.90	107	10.054	0.08	47.00	2.05	0.23
WAVE	20/09/2022 19:39	0.05	4.30	135	10.039	0.092	63.00	2.04	0.22
WAVE	20/09/2022 20:13	0.10	2.70	219	9.983	0.1	79.00	1.98	0.16
WAVE	20/09/2022 20:23	0.07	2.40	119	9.958	0.119	94.00	1.96	0.14
WAVE	20/09/2022 20:33	0.08	3.00	71	9.927	0.173	87.00	1.93	0.11
WAVE	20/09/2022 20:43	0.10	2.30	85	9.891	0.147	73.00	1.89	0.07
WAVE	20/09/2022 20:53	0.06	2.80	247	9.873	0.186	74.00	1.87	0.05
WAVE	20/09/2022 20:13	0.10	2.70	219	9.983	0.1	79.00	1.98	0.16
WAVE	20/09/2022 20:23	0.07	2.40	119	9.958	0.119	94.00	1.96	0.14
WAVE	20/09/2022 20:33	0.08	3.00	71	9.927	0.173	87.00	1.93	0.11
WAVE	20/09/2022 20:43	0.10	2.30	85	9.891	0.147	73.00	1.89	0.07
WAVE	20/09/2022 20:53	0.06	2.80	247	9.873	0.186	74.00	1.87	0.05
WAVE	20/09/2022 22:39	0.07	10.70	39	9.439	0.326	66.00	1.44	-0.38
WAVE	20/09/2022 22:49	0.04	9.10	359	9.402	0.301	66.00	1.40	-0.42
WAVE	20/09/2022 22:59	0.07	8.00	71	9.361	0.293	67.00	1.36	-0.46
WAVE	20/09/2022 23:09	0.07	2.30	227	9.332	0.242	64.00	1.33	-0.49
WAVE	20/09/2022 23:19	0.07	2.00	143	9.284	0.239	67.00	1.28	-0.54
WAVE	20/09/2022 23:29	0.07	12.80	169	9.236	0.231	72.00	1.24	-0.58
WAVE	20/09/2022 23:39	0.07	9.10	169	9.204	0.23	78.00	1.20	-0.62
WAVE	20/09/2022 23:49	0.06	3.80	87	9.17	0.231	75.00	1.17	-0.65
WAVE	20/09/2022 23:59	0.07	2.30	299	9.134	0.208	78.00	1.13	-0.69
WAVE	21/09/2022 00:09	0.04	9.10	131	9.095	0.21	75.00	1.10	-0.72
WAVE	21/09/2022 00:19	0.03	9.10	169	9.075	0.18	71.00	1.08	-0.75
WAVE	21/09/2022 00:29	0.05	12.80	167	9.042	0.161	72.00	1.04	-0.78
WAVE	21/09/2022 00:39	0.04	10.70	315	9.018	0.204	82.00	1.02	-0.80
WAVE	21/09/2022 00:49	0.10	2.50	231	8.998	0.179	80.00	1.00	-0.82
WAVE	21/09/2022 01:22	0.04	3.60	103	8.918	0.083	82.00	0.92	-0.90
WAVE	21/09/2022 01:32	0.03	10.70	79	8.908	0.056	53.00	0.91	-0.91
WAVE	21/09/2022 01:42	0.06	3.20	339	8.899	0.039	49.00	0.90	-0.92
WAVE	21/09/2022 02:16	0.05	5.80	151	8.897	0.05	244.00	0.90	-0.92
WAVE	21/09/2022 02:26	0.03	10.70	169	8.908	0.056	286.00	0.91	-0.91
WAVE	21/09/2022 02:36	0.04	9.10	79	8.914	0.083	262.00	0.91	-0.91
WAVE	21/09/2022 02:46	0.04	16.00	327	8.922	0.104	252.00	0.92	-0.90
WAVE	21/09/2022 02:56	0.04	16.00	315	8.943	0.108	254.00	0.94	-0.88
WAVE	21/09/2022 03:06	0.06	16.00	283	8.969	0.122	254.00	0.97	-0.85
WAVE	21/09/2022 03:16	0.03	12.80	283	8.985	0.136	247.00	0.98	-0.84
WAVE	21/09/2022 03:26	0.05	10.70	275	9.013	0.144	261.00	1.01	-0.81
WAVE	21/09/2022 03:36	0.05	8.00	39	9.048	0.104	244.00	1.05	-0.77
WAVE	21/09/2022 03:46	0.08	2.10	223	9.081	0.099	252.00	1.08	-0.74
WAVE	21/09/2022 03:56	0.06	12.80	159	9.112	0.102	244.00	1.11	-0.71
WAVE	21/09/2022 04:06	0.08	2.30	355	9.159	0.116	239.00	1.16	-0.66
WAVE	21/09/2022 04:16	0.03	9.10	307	9.176	0.119	245.00	1.18	-0.64
WAVE	21/09/2022 04:26	0.12	2.10	215	9.235	0.123	237.00	1.24	-0.59
WAVE	21/09/2022 04:36	0.04	12.80	307	9.278	0.134	243.00	1.28	-0.54
WAVE	21/09/2022 04:46	0.03	21.30	355	9.328	0.178	244.00	1.33	-0.49
WAVE	21/09/2022 04:56	0.20	2.60	125	9.375	0.21	243.00	1.38	-0.45
WAVE	21/09/2022 05:06	0.07	3.40	161	9.424	0.231	239.00	1.42	-0.40
WAVE	21/09/2022 05:16	0.06	3.20	99	9.472	0.247	236.00	1.47	-0.35
WAVE	21/09/2022 05:26	0.06	9.10	15	9.509	0.241	236.00	1.51	-0.31
WAVE	21/09/2022 05:36	0.03	16.00	315	9.557	0.228	251.00	1.56	-0.26
WAVE	21/09/2022 05:46	0.06	10.70	169	9.587	0.216	250.00	1.59	-0.23
WAVE	21/09/2022 05:56	0.04	10.70	79	9.629	0.187	248.00	1.63	-0.19
WAVE	21/09/2022 06:06	0.05	3.60	99	9.677	0.19	259.00	1.68	-0.14
WAVE	21/09/2022 06:16	0.10	2.90	220	9.726	0.198	256.00	1.73	-0.09
WAVE	21/09/2022 06:26	0.08	9.10	339	9.766	0.165	263.00	1.77	-0.05
WAVE	21/09/2022 06:36	0.05	10.70	227	9.808	0.175	255.00	1.81	-0.01
WAVE	21/09/2022 06:46	0.09	2.90	115	9.847	0.192	255.00	1.85	0.03
WAVE	21/09/2022 06:56	0.08	2.70	124	9.883	0.219	260.00	1.88	0.06
WAVE	21/09/2022 07:06	0.07	3.60	167	9.919	0.19	261.00	1.92	0.10
WAVE	21/09/2022 07:16	0.09	2.30	103	9.963	0.176	262.00	1.96	0.14
WAVE	21/09/2022 07:26	0.05	9.10	151	9.988	0.133	263.00	1.99	0.17
WAVE	21/09/2022 07:36	0.11	2.70	238	10.021	0.16	278.00	2.02	0.20

Name	Date Time	Significant Height(m)	Peak Time(sec)	Peak Direction (degree)	ADCP Depth(m)	Current Speed(m/s)	Current Direction (degree)	water level reference to CD	water level reference to 1.82 SHD
WAVE	21/09/2022 07:46	0.06	12.80	47	10.058	0.085	269.00	2.06	0.24
WAVE	21/09/2022 07:56	0.09	2.80	115	10.098	0.075	250.00	2.10	0.28
WAVE	21/09/2022 08:06	0.07	10.70	127	10.124	0.045	246.00	2.12	0.30
WAVE	21/09/2022 08:16	0.07	2.90	311	10.168	0.075	245.00	2.17	0.35
WAVE	21/09/2022 08:26	0.06	8.00	169	10.214	0.057	256.00	2.21	0.39
WAVE	21/09/2022 08:36	0.16	2.70	247	10.246	0.053	284.00	2.25	0.43
WAVE	21/09/2022 08:59	0.15	21.30	3	10.317	0.038	258.00	2.32	0.50
WAVE	21/09/2022 09:09	0.04	10.70	307	10.333	0.071	313.00	2.33	0.51
WAVE	21/09/2022 09:19	0.39	3.00	110	10.361	0.081	282.00	2.36	0.54
WAVE	21/09/2022 09:52	0.23	2.80	131	10.41	0.032	120.00	2.41	0.59
WAVE	21/09/2022 10:02	0.11	2.40	319	10.435	0.056	349.00	2.44	0.62
WAVE	21/09/2022 10:36	0.05	9.10	76	10.427	0.218	62.00	2.43	0.61
WAVE	21/09/2022 10:46	0.03	3.00	180	10.425	0.105	63.00	2.43	0.61
WAVE	21/09/2022 10:56	0.28	2.90	296	10.408	0.089	72.00	2.41	0.59
WAVE	21/09/2022 11:29	0.24	9.10	169	10.36	0.262	61.00	2.36	0.54
WAVE	21/09/2022 11:39	0.06	4.60	259	10.34	0.199	92.00	2.34	0.52
WAVE	21/09/2022 12:12	0.26	16.00	83	10.253	0.294	60.00	2.25	0.43
WAVE	21/09/2022 12:22	0.02	9.10	43	10.22	0.217	72.00	2.22	0.40
WAVE	21/09/2022 12:32	0.08	4.60	115	10.186	0.266	78.00	2.19	0.37
WAVE	21/09/2022 12:42	0.12	2.80	49	10.151	0.239	82.00	2.15	0.33
WAVE	21/09/2022 12:52	0.17	3.00	91	10.129	0.239	66.00	2.13	0.31
WAVE	21/09/2022 13:25	0.40	21.30	67	10.013	0.377	49.00	2.01	0.19
WAVE	21/09/2022 13:35	0.06	3.80	99	9.984	0.203	94.00	1.98	0.16
WAVE	21/09/2022 13:45	0.06	5.80	295	9.955	0.212	95.00	1.96	0.14
WAVE	21/09/2022 13:55	0.04	2.70	119	9.926	0.193	83.00	1.93	0.11
WAVE	21/09/2022 14:29	0.03	9.10	171	9.857	0.218	64.00	1.86	0.04
WAVE	21/09/2022 14:39	0.10	2.80	111	9.859	0.146	96.00	1.86	0.04
WAVE	21/09/2022 14:49	0.15	1.90	112	9.837	0.188	64.00	1.84	0.02
WAVE	21/09/2022 14:59	0.16	2.70	301	9.845	0.082	89.00	1.85	0.03
WAVE	21/09/2022 15:32	0.03	16.00	247	9.864	0.094	37.00	1.86	0.04
WAVE	21/09/2022 15:42	0.09	2.60	91	9.875	0.067	101.00	1.88	0.05
WAVE	21/09/2022 15:52	0.12	2.80	156	9.894	0.021	82.00	1.89	0.07
WAVE	21/09/2022 16:02	0.16	2.90	209	9.914	0.006	272.00	1.91	0.09
WAVE	21/09/2022 16:12	0.12	2.90	101	9.932	0.032	308.00	1.93	0.11
WAVE	21/09/2022 16:22	0.07	21.30	75	9.949	0.045	196.00	1.95	0.13
WAVE	21/09/2022 16:32	0.19	2.90	295	9.967	0.026	222.00	1.97	0.15
WAVE	21/09/2022 17:05	0.02	12.80	3	10.039	0.073	92.00	2.04	0.22
WAVE	21/09/2022 17:15	0.08	3.00	89	10.059	0.047	117.00	2.06	0.24
WAVE	21/09/2022 17:25	0.14	2.80	95	10.058	0.052	100.00	2.06	0.24
WAVE	21/09/2022 17:35	0.05	3.80	85	10.075	0.068	97.00	2.08	0.25
WAVE	21/09/2022 17:45	0.14	2.50	255	10.092	0.06	59.00	2.09	0.27
WAVE	21/09/2022 17:55	0.08	2.80	103	10.097	0.07	96.00	2.10	0.28
WAVE	21/09/2022 18:05	0.26	2.80	327	10.113	0.049	68.00	2.11	0.29
WAVE	21/09/2022 18:38	0.03	12.80	272	10.152	0.106	67.00	2.15	0.33
WAVE	21/09/2022 18:48	0.10	3.20	81	10.176	0.076	66.00	2.18	0.36
WAVE	21/09/2022 19:22	0.03	12.80	215	10.172	0.085	21.00	2.17	0.35
WAVE	21/09/2022 19:32	0.05	3.60	263	10.175	0.037	353.00	2.18	0.36
WAVE	21/09/2022 20:05	0.04	16.00	243	10.196	0.059	82.00	2.20	0.38
WAVE	21/09/2022 20:15	0.08	2.20	167	10.202	0.057	75.00	2.20	0.38
WAVE	21/09/2022 20:25	0.05	9.10	59	10.18	0.061	72.00	2.18	0.36
WAVE	21/09/2022 20:58	0.03	12.80	119	10.17	0.128	102.00	2.17	0.35
WAVE	21/09/2022 21:08	0.06	4.00	127	10.161	0.087	62.00	2.16	0.34
WAVE	21/09/2022 21:18	0.09	2.80	129	10.159	0.098	67.00	2.16	0.34
WAVE	21/09/2022 21:28	0.05	9.10	169	10.145	0.111	68.00	2.15	0.33
WAVE	21/09/2022 21:38	0.06	16.00	323	10.136	0.123	74.00	2.14	0.32
WAVE	21/09/2022 21:48	0.10	2.20	78	10.132	0.113	74.00	2.13	0.31
WAVE	21/09/2022 21:58	0.05	9.10	169	10.088	0.136	64.00	2.09	0.27
WAVE	21/09/2022 22:08	0.06	9.10	169	10.07	0.141	64.00	2.07	0.25
WAVE	21/09/2022 22:42	0.11	9.10	169	9.973	0.164	78.00	1.97	0.15
WAVE	21/09/2022 22:52	0.10	2.10	79	9.94	0.211	73.00	1.94	0.12
WAVE	21/09/2022 23:02	0.06	2.70	85	9.891	0.239	61.00	1.89	0.07
WAVE	21/09/2022 23:12	0.06	2.30	103	9.854	0.263	72.00	1.85	0.03
WAVE	21/09/2022 23:45	0.14	16.00	83	9.666	0.333	81.00	1.67	-0.15
WAVE	21/09/2022 23:55	0.09	2.50	323	9.616	0.31	79.00	1.62	-0.20

Name	Date Time	Significant Height(m)	Peak Time(sec)	Peak Direction (degree)	ADCP Depth(m)	Current Speed(m/s)	Current Direction (degree)	water level reference to CD	water level reference to 1.82 SHD
WAVE	22/09/2022 00:05	0.06	2.40	79	9.556	0.333	74.00	1.56	-0.26
WAVE	22/09/2022 00:38	0.14	10.70	169	9.345	0.311	76.00	1.35	-0.47
WAVE	22/09/2022 00:48	0.03	12.80	359	9.267	0.403	71.00	1.27	-0.55
WAVE	22/09/2022 00:58	0.05	16.00	235	9.206	0.359	65.00	1.21	-0.61
WAVE	22/09/2022 01:08	0.06	21.30	243	9.148	0.314	60.00	1.15	-0.67
WAVE	22/09/2022 01:18	0.07	2.80	77	9.095	0.284	68.00	1.10	-0.72
WAVE	22/09/2022 01:28	0.06	16.00	311	9.034	0.331	60.00	1.03	-0.79
WAVE	22/09/2022 01:38	0.07	21.30	111	8.991	0.286	61.00	0.99	-0.83
WAVE	22/09/2022 02:21	0.08	9.10	263	8.827	0.169	84.00	0.83	-0.99
WAVE	22/09/2022 02:31	0.04	9.10	307	8.8	0.168	92.00	0.80	-1.02
WAVE	22/09/2022 02:41	0.10	2.10	107	8.784	0.142	90.00	0.78	-1.04
WAVE	22/09/2022 02:51	0.05	9.10	169	8.778	0.118	87.00	0.78	-1.04
WAVE	22/09/2022 03:01	0.04	7.10	195	8.775	0.092	85.00	0.78	-1.05
WAVE	22/09/2022 03:11	0.06	12.80	67	8.792	0.054	105.00	0.79	-1.03
WAVE	22/09/2022 03:21	0.04	12.80	311	8.792	0.029	178.00	0.79	-1.03
WAVE	22/09/2022 03:31	0.04	4.90	351	8.805	0.031	232.00	0.81	-1.02
WAVE	22/09/2022 03:41	0.04	8.00	147	8.832	0.068	242.00	0.83	-0.99
WAVE	22/09/2022 03:51	0.10	2.80	99	8.854	0.14	251.00	0.85	-0.97
WAVE	22/09/2022 04:01	0.08	2.20	83	8.882	0.199	244.00	0.88	-0.94
WAVE	22/09/2022 04:11	0.05	8.00	11	8.912	0.236	250.00	0.91	-0.91
WAVE	22/09/2022 04:21	0.06	9.10	163	8.952	0.269	261.00	0.95	-0.87
WAVE	22/09/2022 04:31	0.03	9.10	275	9	0.308	256.00	1.00	-0.82
WAVE	22/09/2022 04:41	0.05	21.30	171	9.064	0.286	262.00	1.06	-0.76
WAVE	22/09/2022 04:51	0.03	10.70	83	9.099	0.303	259.00	1.10	-0.72
WAVE	22/09/2022 05:01	0.03	9.10	251	9.14	0.312	265.00	1.14	-0.68
WAVE	22/09/2022 05:11	0.20	3.60	241	9.206	0.319	269.00	1.21	-0.61
WAVE	22/09/2022 05:21	0.08	2.40	347	9.265	0.316	275.00	1.27	-0.55
WAVE	22/09/2022 05:31	0.04	2.90	191	9.323	0.317	269.00	1.32	-0.50
WAVE	22/09/2022 05:41	0.04	7.10	279	9.38	0.307	267.00	1.38	-0.44
WAVE	22/09/2022 05:51	0.05	12.80	83	9.443	0.3	266.00	1.44	-0.38
WAVE	22/09/2022 06:01	0.06	2.30	59	9.5	0.313	269.00	1.50	-0.32
WAVE	22/09/2022 06:11	0.06	2.50	115	9.549	0.292	265.00	1.55	-0.27
WAVE	22/09/2022 06:21	0.07	2.70	357	9.607	0.302	259.00	1.61	-0.21
WAVE	22/09/2022 06:31	0.09	2.70	91	9.644	0.363	266.00	1.64	-0.18
WAVE	22/09/2022 06:41	0.04	9.10	323	9.701	0.337	261.00	1.70	-0.12
WAVE	22/09/2022 07:15	0.16	2.70	315	9.884	0.353	271.00	1.88	0.06
WAVE	22/09/2022 07:25	0.06	12.80	335	9.949	0.298	265.00	1.95	0.13
WAVE	22/09/2022 07:35	0.13	2.10	107	10.023	0.305	270.00	2.02	0.20
WAVE	22/09/2022 07:45	0.15	2.10	127	10.076	0.289	271.00	2.08	0.26
WAVE	22/09/2022 07:55	0.13	2.60	255	10.118	0.261	273.00	2.12	0.30
WAVE	22/09/2022 08:05	0.14	2.20	359	10.156	0.242	258.00	2.16	0.34
WAVE	22/09/2022 08:15	0.03	16.00	35	10.189	0.222	253.00	2.19	0.37
WAVE	22/09/2022 08:25	0.09	2.60	263	10.247	0.17	243.00	2.25	0.43
WAVE	22/09/2022 08:35	0.16	2.30	256	10.294	0.104	263.00	2.29	0.47
WAVE	22/09/2022 08:45	0.25	2.10	1	10.343	0.089	250.00	2.34	0.52
WAVE	22/09/2022 09:18	0.03	10.70	51	10.414	0.175	69.00	2.41	0.59
WAVE	22/09/2022 09:28	0.06	4.60	103	10.421	0.08	100.00	2.42	0.60
WAVE	22/09/2022 09:38	0.09	2.40	147	10.436	0.099	73.00	2.44	0.62
WAVE	22/09/2022 09:48	0.12	2.00	347	10.428	0.115	58.00	2.43	0.61
WAVE	22/09/2022 10:21	0.03	12.80	300	10.423	0.348	74.00	2.42	0.60
WAVE	22/09/2022 10:31	0.27	2.30	200	10.416	0.176	65.00	2.42	0.60
WAVE	22/09/2022 11:04	0.03	9.10	276	10.361	0.322	83.00	2.36	0.54
WAVE	22/09/2022 11:14	0.07	10.70	170	10.336	0.222	72.00	2.34	0.52
WAVE	22/09/2022 11:48	0.29	12.80	135	10.228	0.273	83.00	2.23	0.41
WAVE	22/09/2022 11:58	0.08	12.80	347	10.211	0.228	66.00	2.21	0.39
WAVE	22/09/2022 12:08	0.07	3.40	107	10.181	0.225	66.00	2.18	0.36
WAVE	22/09/2022 12:18	0.06	12.80	351	10.128	0.214	67.00	2.13	0.31
WAVE	22/09/2022 12:28	0.11	3.20	215	10.096	0.225	68.00	2.10	0.28
WAVE	22/09/2022 13:01	0.21	3.40	302	9.954	0.233	70.00	1.95	0.13
WAVE	22/09/2022 13:11	0.07	2.50	259	9.918	0.249	69.00	1.92	0.10
WAVE	22/09/2022 13:21	0.09	3.60	59	9.885	0.249	63.00	1.89	0.06
WAVE	22/09/2022 13:31	0.06	12.80	169	9.851	0.258	67.00	1.85	0.03
WAVE	22/09/2022 14:04	0.38	12.80	259	9.738	0.254	64.00	1.74	-0.08
WAVE	22/09/2022 14:14	0.11	2.90	89	9.718	0.235	70.00	1.72	-0.10

Name	Date Time	Significant Height(m)	Peak Time(sec)	Peak Direction (degree)	ADCP Depth(m)	Current Speed(m/s)	Current Direction (degree)	water level reference to CD	water level reference to 1.82 SHD
WAVE	22/09/2022 14:24	0.09	3.60	91	9.701	0.253	57.00	1.70	-0.12
WAVE	22/09/2022 14:58	0.03	12.80	279	9.659	0.13	70.00	1.66	-0.16
WAVE	22/09/2022 15:08	0.21	2.70	215	9.651	0.195	51.00	1.65	-0.17
WAVE	22/09/2022 15:18	0.14	2.90	299	9.639	0.153	56.00	1.64	-0.18
WAVE	22/09/2022 15:28	0.09	2.90	75	9.641	0.127	52.00	1.64	-0.18
WAVE	22/09/2022 15:38	0.11	2.80	289	9.625	0.097	55.00	1.63	-0.20
WAVE	22/09/2022 16:11	0.36	9.10	169	9.664	0.138	67.00	1.66	-0.16
WAVE	22/09/2022 16:21	0.21	2.10	235	9.686	0.119	45.00	1.69	-0.13
WAVE	22/09/2022 16:31	0.12	2.60	263	9.674	0.085	51.00	1.67	-0.15
WAVE	22/09/2022 16:41	0.07	2.70	347	9.702	0.082	35.00	1.70	-0.12
WAVE	22/09/2022 16:51	0.13	2.80	115	9.718	0.061	342.00	1.72	-0.10
WAVE	22/09/2022 17:01	0.08	2.50	87	9.745	0.026	5.00	1.75	-0.08
WAVE	22/09/2022 17:11	0.19	2.90	265	9.757	0.036	67.00	1.76	-0.06
WAVE	22/09/2022 17:21	0.20	2.90	90	9.784	0.06	20.00	1.78	-0.04
WAVE	22/09/2022 17:31	0.10	2.60	78	9.81	0.082	4.00	1.81	-0.01
WAVE	22/09/2022 17:41	0.08	2.80	91	9.841	0.03	4.00	1.84	0.02
WAVE	22/09/2022 17:51	0.08	3.00	115	9.868	0.029	16.00	1.87	0.05
WAVE	22/09/2022 18:01	0.03	10.70	343	9.893	0.021	328.00	1.89	0.07
WAVE	22/09/2022 18:11	0.07	10.70	169	9.908	0.013	330.00	1.91	0.09
WAVE	22/09/2022 18:21	0.04	12.80	169	9.943	0.017	332.00	1.94	0.12
WAVE	22/09/2022 18:31	0.10	2.50	96	9.969	0.01	311.00	1.97	0.15
WAVE	22/09/2022 18:41	0.12	2.50	83	10.014	0.033	273.00	2.01	0.19
WAVE	22/09/2022 18:51	0.13	2.80	108	10.039	0.023	248.00	2.04	0.22
WAVE	22/09/2022 19:01	0.10	2.50	81	10.07	0.034	256.00	2.07	0.25
WAVE	22/09/2022 19:11	0.09	2.70	91	10.111	0.027	265.00	2.11	0.29
WAVE	22/09/2022 19:44	0.28	10.70	147	10.18	0.078	44.00	2.18	0.36
WAVE	22/09/2022 19:54	0.11	2.90	249	10.22	0.011	203.00	2.22	0.40
WAVE	22/09/2022 20:04	0.18	3.00	287	10.25	0.036	243.00	2.25	0.43
WAVE	22/09/2022 20:14	0.06	21.30	271	10.269	0.016	305.00	2.27	0.45
WAVE	22/09/2022 20:24	0.04	10.70	169	10.298	0.02	306.00	2.30	0.48
WAVE	22/09/2022 20:34	0.03	12.80	71	10.319	0.011	82.00	2.32	0.50
WAVE	22/09/2022 20:44	0.05	3.20	331	10.34	0.033	64.00	2.34	0.52
WAVE	22/09/2022 20:54	0.06	10.70	163	10.355	0.042	67.00	2.36	0.54
WAVE	22/09/2022 21:04	0.04	16.00	235	10.355	0.052	79.00	2.36	0.54
WAVE	22/09/2022 21:14	0.07	2.30	55	10.363	0.087	73.00	2.36	0.54
WAVE	22/09/2022 21:24	0.07	2.60	131	10.365	0.087	82.00	2.37	0.55
WAVE	22/09/2022 21:34	0.07	3.60	99	10.379	0.113	83.00	2.38	0.56
WAVE	22/09/2022 22:07	0.11	9.10	23	10.356	0.194	79.00	2.36	0.54
WAVE	22/09/2022 22:17	0.07	2.60	279	10.339	0.151	89.00	2.34	0.52
WAVE	22/09/2022 22:27	0.06	9.10	351	10.32	0.095	81.00	2.32	0.50
WAVE	22/09/2022 22:37	0.06	3.60	115	10.319	0.178	79.00	2.32	0.50
WAVE	22/09/2022 23:11	0.07	9.10	115	10.193	0.312	72.00	2.19	0.37
WAVE	22/09/2022 23:21	0.14	2.00	23	10.145	0.269	74.00	2.15	0.33
WAVE	22/09/2022 23:31	0.04	10.70	7	10.09	0.22	64.00	2.09	0.27
WAVE	22/09/2022 23:41	0.04	5.80	107	10.012	0.285	72.00	2.01	0.19
WAVE	22/09/2022 23:51	0.06	9.10	181	9.959	0.3	77.00	1.96	0.14
WAVE	23/09/2022 00:24	0.05	9.10	303	9.743	0.366	74.00	1.74	-0.08
WAVE	23/09/2022 00:34	0.05	16.00	169	9.652	0.373	77.00	1.65	-0.17
WAVE	23/09/2022 00:44	0.05	9.10	327	9.578	0.384	72.00	1.58	-0.24
WAVE	23/09/2022 00:54	0.06	3.40	89	9.51	0.343	74.00	1.51	-0.31
WAVE	23/09/2022 01:27	0.04	9.10	159	9.25	0.188	66.00	1.25	-0.57
WAVE	23/09/2022 01:37	0.07	2.40	147	9.19	0.259	58.00	1.19	-0.63
WAVE	23/09/2022 01:47	0.07	7.10	155	9.113	0.195	68.00	1.11	-0.71
WAVE	23/09/2022 01:57	0.04	8.00	119	9.047	0.204	63.00	1.05	-0.77
WAVE	23/09/2022 02:30	0.07	8.00	74	8.853	0.23	48.00	0.85	-0.97
WAVE	23/09/2022 02:40	0.04	9.10	59	8.822	0.165	56.00	0.82	-1.00
WAVE	23/09/2022 02:50	0.14	2.10	174	8.755	0.148	60.00	0.76	-1.07
WAVE	23/09/2022 03:00	0.05	10.70	167	8.731	0.08	90.00	0.73	-1.09
WAVE	23/09/2022 03:10	0.07	2.70	347	8.71	0.115	83.00	0.71	-1.11
WAVE	23/09/2022 03:20	0.03	16.00	23	8.696	0.16	67.00	0.70	-1.12
WAVE	23/09/2022 03:30	0.05	21.30	231	8.675	0.13	74.00	0.68	-1.15
WAVE	23/09/2022 03:40	0.04	10.70	55	8.674	0.132	67.00	0.67	-1.15
WAVE	23/09/2022 03:50	0.02	16.00	359	8.677	0.072	65.00	0.68	-1.14
WAVE	23/09/2022 04:00	0.03	12.80	239	8.691	0.051	61.00	0.69	-1.13

Name	Date Time	Significant Height(m)	Peak Time(sec)	Peak Direction (degree)	ADCP Depth(m)	Current Speed(m/s)	Current Direction (degree)	water level reference to CD	water level reference to 1.82 SHD
WAVE	23/09/2022 04:10	0.07	2.20	235	8.725	0.034	159.00	0.73	-1.10
WAVE	23/09/2022 04:20	0.03	21.30	359	8.733	0.059	243.00	0.73	-1.09
WAVE	23/09/2022 04:30	0.08	1.90	27	8.74	0.086	246.00	0.74	-1.08
WAVE	23/09/2022 04:40	0.07	2.70	77	8.769	0.139	242.00	0.77	-1.05
WAVE	23/09/2022 04:50	0.08	9.10	355	8.806	0.172	243.00	0.81	-1.01
WAVE	23/09/2022 05:00	0.05	7.10	59	8.843	0.152	245.00	0.84	-0.98
WAVE	23/09/2022 05:10	0.03	21.30	103	8.866	0.123	263.00	0.87	-0.95
WAVE	23/09/2022 05:20	0.03	10.70	83	8.939	0.196	259.00	0.94	-0.88
WAVE	23/09/2022 05:30	0.03	12.80	123	8.993	0.261	254.00	0.99	-0.83
WAVE	23/09/2022 05:40	0.05	21.30	131	9.045	0.321	255.00	1.05	-0.78
WAVE	23/09/2022 05:50	0.06	12.80	107	9.105	0.303	262.00	1.11	-0.72
WAVE	23/09/2022 06:00	0.05	3.20	123	9.155	0.314	261.00	1.16	-0.67
WAVE	23/09/2022 06:10	0.04	12.80	43	9.221	0.311	264.00	1.22	-0.60
WAVE	23/09/2022 06:20	0.12	2.00	169	9.287	0.315	261.00	1.29	-0.53
WAVE	23/09/2022 06:30	0.08	2.90	147	9.348	0.329	261.00	1.35	-0.47
WAVE	23/09/2022 06:40	0.15	1.90	135	9.407	0.279	258.00	1.41	-0.41
WAVE	23/09/2022 06:50	0.13	2.40	307	9.476	0.283	260.00	1.48	-0.34
WAVE	23/09/2022 07:00	0.16	3.40	296	9.532	0.27	262.00	1.53	-0.29
WAVE	23/09/2022 07:10	0.08	21.30	87	9.598	0.246	264.00	1.60	-0.22
WAVE	23/09/2022 07:20	0.11	2.10	95	9.663	0.22	264.00	1.66	-0.16
WAVE	23/09/2022 07:30	0.09	2.60	87	9.712	0.211	266.00	1.71	-0.11
WAVE	23/09/2022 07:40	0.13	2.70	267	9.783	0.241	265.00	1.78	-0.04
WAVE	23/09/2022 07:50	0.06	3.00	275	9.834	0.181	266.00	1.83	0.01
WAVE	23/09/2022 08:00	0.08	2.80	118	9.888	0.202	254.00	1.89	0.07
WAVE	23/09/2022 08:10	0.05	3.60	27	9.943	0.236	265.00	1.94	0.12
WAVE	23/09/2022 08:20	0.09	2.20	275	9.996	0.226	270.00	2.00	0.18
WAVE	23/09/2022 08:30	0.14	3.40	235	10.054	0.225	273.00	2.05	0.23
WAVE	23/09/2022 08:40	0.03	12.80	311	10.097	0.256	281.00	2.10	0.28
WAVE	23/09/2022 08:50	0.10	3.60	111	10.153	0.255	263.00	2.15	0.33
WAVE	23/09/2022 09:00	0.06	16.00	107	10.198	0.215	265.00	2.20	0.38
WAVE	23/09/2022 09:10	0.16	2.30	242	10.251	0.205	265.00	2.25	0.43
WAVE	23/09/2022 09:20	0.18	2.30	227	10.298	0.184	260.00	2.30	0.48
WAVE	23/09/2022 09:30	0.10	2.80	115	10.337	0.174	264.00	2.34	0.52
WAVE	23/09/2022 09:40	0.28	3.00	104	10.387	0.153	262.00	2.39	0.57
WAVE	23/09/2022 09:50	0.08	2.10	319	10.419	0.146	259.00	2.42	0.60
WAVE	23/09/2022 10:00	0.07	10.70	147	10.461	0.113	245.00	2.46	0.64
WAVE	23/09/2022 10:10	0.08	2.50	83	10.497	0.114	251.00	2.50	0.68
WAVE	23/09/2022 10:20	0.07	3.00	251	10.524	0.088	242.00	2.52	0.70
WAVE	23/09/2022 10:30	0.03	12.80	323	10.547	0.047	222.00	2.55	0.73
WAVE	23/09/2022 10:40	0.06	10.70	123	10.553	0.034	238.00	2.55	0.73
WAVE	23/09/2022 10:50	0.07	2.80	110	10.552	0.019	161.00	2.55	0.73
WAVE	23/09/2022 11:00	0.05	21.30	271	10.562	0.038	58.00	2.56	0.74
WAVE	23/09/2022 11:34	0.15	10.70	71	10.527	0.168	60.00	2.53	0.71
WAVE	23/09/2022 11:44	0.08	3.00	115	10.516	0.2	88.00	2.52	0.70
WAVE	23/09/2022 12:17	0.20	9.10	303	10.446	0.219	101.00	2.45	0.63
WAVE	23/09/2022 12:27	0.12	2.60	84	10.418	0.205	95.00	2.42	0.60
WAVE	23/09/2022 12:37	0.17	2.40	141	10.379	0.228	87.00	2.38	0.56
WAVE	23/09/2022 12:47	0.12	2.90	86	10.34	0.234	79.00	2.34	0.52
WAVE	23/09/2022 12:57	0.16	2.10	114	10.267	0.258	72.00	2.27	0.45
WAVE	23/09/2022 13:30	0.18	3.00	197	10.094	0.244	93.00	2.09	0.27
WAVE	23/09/2022 13:40	0.03	12.80	107	10.037	0.233	68.00	2.04	0.22
WAVE	23/09/2022 13:50	0.24	2.10	98	9.985	0.26	66.00	1.99	0.16
WAVE	23/09/2022 14:24	0.22	2.90	86	9.798	0.324	69.00	1.80	-0.02
WAVE	23/09/2022 14:34	0.07	2.90	87	9.753	0.267	61.00	1.75	-0.07
WAVE	23/09/2022 14:44	0.10	2.80	83	9.685	0.228	64.00	1.69	-0.14
WAVE	23/09/2022 14:54	0.15	2.10	86	9.648	0.279	63.00	1.65	-0.17
WAVE	23/09/2022 15:27	0.17	16.00	259	9.532	0.26	57.00	1.53	-0.29
WAVE	23/09/2022 15:37	0.07	2.80	101	9.52	0.214	71.00	1.52	-0.30
WAVE	23/09/2022 15:47	0.06	2.80	107	9.509	0.176	71.00	1.51	-0.31
WAVE	23/09/2022 15:57	0.10	2.60	75	9.522	0.117	85.00	1.52	-0.30
WAVE	23/09/2022 16:07	0.13	3.20	99	9.521	0.101	92.00	1.52	-0.30
WAVE	23/09/2022 16:17	0.12	2.80	104	9.513	0.045	113.00	1.51	-0.31
WAVE	23/09/2022 16:27	0.17	2.70	304	9.541	0.095	231.00	1.54	-0.28
WAVE	23/09/2022 16:37	0.11	2.30	99	9.559	0.132	243.00	1.56	-0.26

Name	Date Time	Significant Height(m)	Peak Time(sec)	Peak Direction (degree)	ADCP Depth(m)	Current Speed(m/s)	Current Direction (degree)	water level reference to CD	water level reference to 1.82 SHD
WAVE	23/09/2022 16:47	0.10	2.60	79	9.58	0.14	246.00	1.58	-0.24
WAVE	23/09/2022 16:57	0.06	4.30	103	9.61	0.121	262.00	1.61	-0.21
WAVE	23/09/2022 17:07	0.04	9.10	139	9.632	0.133	255.00	1.63	-0.19
WAVE	23/09/2022 17:17	0.08	3.00	43	9.678	0.134	257.00	1.68	-0.14
WAVE	23/09/2022 17:27	0.19	3.20	298	9.716	0.152	270.00	1.72	-0.10
WAVE	23/09/2022 17:37	0.06	9.10	355	9.758	0.177	257.00	1.76	-0.06
WAVE	23/09/2022 17:47	0.06	2.60	9	9.797	0.171	254.00	1.80	-0.02
WAVE	23/09/2022 18:20	0.32	2.90	313	9.95	0.105	224.00	1.95	0.13
WAVE	23/09/2022 18:30	0.06	9.10	169	9.998	0.085	246.00	2.00	0.18
WAVE	23/09/2022 18:40	0.08	2.70	101	10.021	0.091	236.00	2.02	0.20
WAVE	23/09/2022 18:50	0.06	12.80	235	10.061	0.124	246.00	2.06	0.24
WAVE	23/09/2022 19:00	0.17	3.00	113	10.105	0.147	244.00	2.11	0.29
WAVE	23/09/2022 19:10	0.07	2.90	343	10.146	0.179	261.00	2.15	0.33
WAVE	23/09/2022 19:20	0.07	4.00	103	10.188	0.194	265.00	2.19	0.37
WAVE	23/09/2022 19:30	0.06	2.80	71	10.237	0.211	253.00	2.24	0.42
WAVE	23/09/2022 19:40	0.10	2.90	87	10.286	0.183	259.00	2.29	0.47
WAVE	23/09/2022 19:50	0.06	4.00	279	10.32	0.183	259.00	2.32	0.50
WAVE	23/09/2022 20:23	0.03	10.70	123	10.416	0.116	263.00	2.42	0.60
WAVE	23/09/2022 20:33	0.05	12.80	239	10.461	0.136	257.00	2.46	0.64
WAVE	23/09/2022 21:07	0.16	9.10	83	10.551	0.092	291.00	2.55	0.73
WAVE	23/09/2022 21:17	0.08	2.70	107	10.576	0.097	277.00	2.58	0.76
WAVE	23/09/2022 21:27	0.07	3.60	79	10.6	0.072	283.00	2.60	0.78
WAVE	23/09/2022 21:37	0.05	5.30	11	10.607	0.049	259.00	2.61	0.79
WAVE	23/09/2022 21:47	0.09	2.90	305	10.626	0.033	293.00	2.63	0.81
WAVE	23/09/2022 22:20	0.17	9.10	169	10.624	0.034	86.00	2.62	0.80
WAVE	23/09/2022 22:30	0.05	12.80	255	10.613	0.043	93.00	2.61	0.79
WAVE	23/09/2022 22:40	0.05	2.70	99	10.6	0.054	100.00	2.60	0.78
WAVE	23/09/2022 23:13	0.15	16.00	167	10.53	0.197	62.00	2.53	0.71
WAVE	23/09/2022 23:23	0.04	10.70	7	10.472	0.125	103.00	2.47	0.65
WAVE	23/09/2022 23:33	0.05	9.10	235	10.463	0.199	87.00	2.46	0.64
WAVE	23/09/2022 23:43	0.07	12.80	127	10.399	0.217	81.00	2.40	0.58
WAVE	24/09/2022 00:16	0.08	9.10	87	10.205	0.285	73.00	2.21	0.39
WAVE	24/09/2022 00:26	0.02	9.10	199	10.138	0.318	73.00	2.14	0.32
WAVE	24/09/2022 00:36	0.03	10.70	99	10.057	0.367	73.00	2.06	0.24
WAVE	24/09/2022 01:10	0.06	10.70	151	9.773	0.266	82.00	1.77	-0.05
WAVE	24/09/2022 01:20	0.02	10.70	119	9.687	0.224	64.00	1.69	-0.13
WAVE	24/09/2022 01:30	0.04	8.00	283	9.595	0.238	60.00	1.60	-0.22
WAVE	24/09/2022 02:03	0.06	3.60	95	9.313	0.284	80.00	1.31	-0.51
WAVE	24/09/2022 02:13	0.09	2.20	223	9.212	0.325	75.00	1.21	-0.61
WAVE	24/09/2022 02:23	0.05	7.10	355	9.117	0.371	61.00	1.12	-0.70
WAVE	24/09/2022 02:33	0.06	8.00	169	9.028	0.364	47.00	1.03	-0.79
WAVE	24/09/2022 03:06	0.04	9.10	283	8.784	0.367	30.00	0.78	-1.04
WAVE	24/09/2022 03:16	0.03	9.10	35	8.724	0.388	35.00	0.72	-1.10
WAVE	24/09/2022 03:26	0.06	5.80	267	8.691	0.197	40.00	0.69	-1.13
WAVE	24/09/2022 03:36	0.05	21.30	75	8.618	0.18	39.00	0.62	-1.20
WAVE	24/09/2022 03:46	0.05	10.70	83	8.605	0.048	333.00	0.61	-1.22
WAVE	24/09/2022 03:56	0.08	21.30	115	8.582	0.074	275.00	0.58	-1.24
WAVE	24/09/2022 04:06	0.04	9.10	169	8.575	0.093	272.00	0.57	-1.25
WAVE	24/09/2022 04:40	0.07	21.30	259	8.601	0.165	250.00	0.60	-1.22
WAVE	24/09/2022 04:50	0.08	2.60	67	8.63	0.198	254.00	0.63	-1.19
WAVE	24/09/2022 05:00	0.04	10.70	239	8.659	0.217	258.00	0.66	-1.16
WAVE	24/09/2022 05:10	0.04	16.00	103	8.681	0.222	268.00	0.68	-1.14
WAVE	24/09/2022 05:20	0.04	12.80	51	8.718	0.236	262.00	0.72	-1.10
WAVE	24/09/2022 05:30	0.06	2.10	55	8.774	0.258	252.00	0.77	-1.05
WAVE	24/09/2022 05:40	0.05	3.20	169	8.819	0.3	254.00	0.82	-1.00
WAVE	24/09/2022 05:50	0.06	16.00	231	8.875	0.388	255.00	0.88	-0.95
WAVE	24/09/2022 06:00	0.05	10.70	167	8.94	0.387	257.00	0.94	-0.88
WAVE	24/09/2022 06:10	0.05	9.10	91	9.006	0.427	260.00	1.01	-0.81
WAVE	24/09/2022 06:20	0.06	16.00	163	9.072	0.392	267.00	1.07	-0.75
WAVE	24/09/2022 06:30	0.05	10.70	255	9.152	0.364	262.00	1.15	-0.67
WAVE	24/09/2022 07:03	0.26	9.10	303	9.408	0.255	257.00	1.41	-0.41
WAVE	24/09/2022 07:13	0.15	1.90	305	9.477	0.333	265.00	1.48	-0.34
WAVE	24/09/2022 07:23	0.06	3.20	115	9.546	0.356	266.00	1.55	-0.27
WAVE	24/09/2022 07:33	0.08	2.40	307	9.604	0.333	260.00	1.60	-0.22

Name	Date Time	Significant Height(m)	Peak Time(sec)	Peak Direction (degree)	ADCP Depth(m)	Current Speed(m/s)	Current Direction (degree)	water level reference to CD	water level reference to 1.82 SHD
WAVE	24/09/2022 07:43	0.02	21.30	283	9.666	0.288	268.00	1.67	-0.15
WAVE	24/09/2022 08:16	0.21	2.80	1	9.898	0.107	255.00	1.90	0.08
WAVE	24/09/2022 08:26	0.10	2.70	263	9.958	0.083	284.00	1.96	0.14
WAVE	24/09/2022 08:36	0.25	3.20	112	10.006	0.047	264.00	2.01	0.19
WAVE	24/09/2022 08:46	0.11	3.00	287	10.073	0.107	248.00	2.07	0.25
WAVE	24/09/2022 08:56	0.21	2.80	108	10.134	0.149	265.00	2.13	0.31
WAVE	24/09/2022 09:06	0.28	2.60	132	10.194	0.083	297.00	2.19	0.37
WAVE	24/09/2022 09:39	0.26	2.70	343	10.384	0.141	275.00	2.38	0.56
WAVE	24/09/2022 09:49	0.07	4.00	95	10.429	0.177	258.00	2.43	0.61
WAVE	24/09/2022 09:59	0.19	2.80	106	10.479	0.14	253.00	2.48	0.66
WAVE	24/09/2022 10:09	0.08	2.80	139	10.523	0.098	240.00	2.52	0.70
WAVE	24/09/2022 10:43	0.29	9.10	59	10.65	0.045	0.00	2.65	0.83
WAVE	24/09/2022 10:53	0.07	2.90	95	10.644	0.037	232.00	2.64	0.82
WAVE	24/09/2022 11:03	0.10	2.30	136	10.665	0.024	71.00	2.67	0.84
WAVE	24/09/2022 11:13	0.12	2.10	99	10.671	0.079	93.00	2.67	0.85
WAVE	24/09/2022 11:46	0.25	2.90	101	10.639	0.231	61.00	2.64	0.82
WAVE	24/09/2022 11:56	0.09	2.70	102	10.622	0.199	57.00	2.62	0.80
WAVE	24/09/2022 12:06	0.17	2.80	104	10.598	0.216	48.00	2.60	0.78
WAVE	24/09/2022 12:39	0.17	2.90	324	10.476	0.327	87.00	2.48	0.66
WAVE	24/09/2022 12:49	0.13	2.30	74	10.425	0.287	74.00	2.43	0.61
WAVE	24/09/2022 13:22	0.14	2.40	143	10.257	0.319	77.00	2.26	0.44
WAVE	24/09/2022 13:32	0.08	2.90	103	10.191	0.281	76.00	2.19	0.37
WAVE	24/09/2022 13:42	0.03	9.10	87	10.119	0.288	77.00	2.12	0.30
WAVE	24/09/2022 14:16	0.16	3.20	110	9.878	0.304	63.00	1.88	0.06
WAVE	24/09/2022 14:26	0.09	3.00	79	9.796	0.225	80.00	1.80	-0.02
WAVE	24/09/2022 14:36	0.17	3.20	95	9.74	0.253	74.00	1.74	-0.08
WAVE	24/09/2022 14:46	0.05	4.00	71	9.674	0.215	68.00	1.67	-0.15
WAVE	24/09/2022 15:19	0.30	10.70	141	9.457	0.19	80.00	1.46	-0.36
WAVE	24/09/2022 15:29	0.15	3.00	86	9.401	0.258	61.00	1.40	-0.42
WAVE	24/09/2022 15:39	0.08	2.80	87	9.315	0.219	52.00	1.32	-0.51
WAVE	24/09/2022 16:12	0.21	9.10	99	9.213	0.139	60.00	1.21	-0.61
WAVE	24/09/2022 16:22	0.04	12.80	169	9.211	0.211	49.00	1.21	-0.61
WAVE	24/09/2022 16:32	0.07	3.20	83	9.209	0.137	49.00	1.21	-0.61
WAVE	24/09/2022 16:42	0.09	3.00	87	9.222	0.09	48.00	1.22	-0.60
WAVE	24/09/2022 17:16	0.15	12.80	343	9.287	0.037	309.00	1.29	-0.53
WAVE	24/09/2022 17:26	0.08	3.60	253	9.343	0.064	309.00	1.34	-0.48
WAVE	24/09/2022 17:36	0.10	2.60	127	9.379	0.101	294.00	1.38	-0.44
WAVE	24/09/2022 18:09	0.21	3.40	293	9.543	0.156	294.00	1.54	-0.28
WAVE	24/09/2022 18:19	0.06	21.30	71	9.608	0.184	263.00	1.61	-0.21
WAVE	24/09/2022 18:29	0.11	2.90	113	9.661	0.168	269.00	1.66	-0.16
WAVE	24/09/2022 18:39	0.12	2.40	167	9.717	0.161	262.00	1.72	-0.10
WAVE	24/09/2022 19:12	0.26	9.10	169	9.907	0.092	290.00	1.91	0.09
WAVE	24/09/2022 19:22	0.27	3.00	110	9.974	0.123	257.00	1.97	0.15
WAVE	24/09/2022 19:32	0.06	3.60	255	10.003	0.173	251.00	2.00	0.18
WAVE	24/09/2022 19:42	0.09	2.60	231	10.066	0.125	253.00	2.07	0.25
WAVE	24/09/2022 19:52	0.05	7.10	159	10.135	0.114	252.00	2.14	0.32
WAVE	24/09/2022 20:02	0.06	10.70	19	10.196	0.101	248.00	2.20	0.38
WAVE	24/09/2022 20:35	0.15	9.10	247	10.386	0.143	276.00	2.39	0.57
WAVE	24/09/2022 20:45	0.08	3.40	247	10.452	0.163	265.00	2.45	0.63
WAVE	24/09/2022 20:55	0.08	2.40	47	10.519	0.161	262.00	2.52	0.70
WAVE	24/09/2022 21:05	0.07	2.10	127	10.567	0.138	271.00	2.57	0.75
WAVE	24/09/2022 21:15	0.02	9.10	169	10.611	0.17	271.00	2.61	0.79
WAVE	24/09/2022 21:25	0.02	12.80	127	10.666	0.159	274.00	2.67	0.85
WAVE	24/09/2022 21:35	0.10	3.40	169	10.715	0.16	278.00	2.72	0.90
WAVE	24/09/2022 22:09	0.12	10.70	11	10.837	0.15	329.00	2.84	1.02
WAVE	24/09/2022 22:19	0.05	10.70	169	10.859	0.076	278.00	2.86	1.04
WAVE	24/09/2022 22:52	0.16	10.70	169	10.883	0.074	64.00	2.88	1.06
WAVE	24/09/2022 23:02	0.06	12.80	143	10.89	0.104	58.00	2.89	1.07
WAVE	24/09/2022 23:12	0.14	2.00	91	10.882	0.091	60.00	2.88	1.06
WAVE	24/09/2022 23:22	0.06	3.80	105	10.854	0.144	66.00	2.85	1.03
WAVE	24/09/2022 23:32	0.04	4.30	247	10.837	0.134	82.00	2.84	1.02
WAVE	25/09/2022 00:05	0.10	2.10	119	10.701	0.364	59.00	2.70	0.88
WAVE	25/09/2022 00:15	0.03	4.90	171	10.659	0.267	71.00	2.66	0.84
WAVE	25/09/2022 00:25	0.04	21.30	169	10.595	0.317	76.00	2.60	0.78

Name	Date Time	Significant Height(m)	Peak Time(sec)	Peak Direction (degree)	ADCP Depth(m)	Current Speed(m/s)	Current Direction (degree)	water level reference to CD	water level reference to 1.82 SHD
WAVE	25/09/2022 00:58	0.15	4.00	83	10.334	0.459	74.00	2.33	0.51
WAVE	25/09/2022 01:08	0.18	3.80	103	10.242	0.446	77.00	2.24	0.42
WAVE	25/09/2022 01:18	0.08	3.80	87	10.147	0.42	76.00	2.15	0.33
WAVE	25/09/2022 01:28	0.05	12.80	235	10.06	0.454	67.00	2.06	0.24
WAVE	25/09/2022 02:02	0.05	9.10	323	9.735	0.184	88.00	1.74	-0.09
WAVE	25/09/2022 02:12	0.04	12.80	35	9.641	0.322	90.00	1.64	-0.18
WAVE	25/09/2022 02:45	0.08	10.70	75	9.336	0.299	78.00	1.34	-0.48
WAVE	25/09/2022 02:55	0.06	9.10	295	9.211	0.226	87.00	1.21	-0.61
WAVE	25/09/2022 03:05	0.08	2.60	249	9.12	0.209	90.00	1.12	-0.70
WAVE	25/09/2022 03:15	0.08	2.10	31	9.04	0.192	96.00	1.04	-0.78
WAVE	25/09/2022 03:25	0.07	2.30	187	8.959	0.18	92.00	0.96	-0.86
WAVE	25/09/2022 03:35	0.02	12.80	271	8.887	0.13	100.00	0.89	-0.93
WAVE	25/09/2022 03:45	0.02	12.80	215	8.823	0.141	58.00	0.82	-1.00
WAVE	25/09/2022 03:55	0.03	9.10	75	8.763	0.083	59.00	0.76	-1.06
WAVE	25/09/2022 04:05	0.03	10.70	151	8.718	0.083	52.00	0.72	-1.10
WAVE	25/09/2022 04:15	0.04	9.10	299	8.683	0.131	16.00	0.68	-1.14
WAVE	25/09/2022 04:48	0.07	12.80	47	8.605	0.131	357.00	0.61	-1.22
WAVE	25/09/2022 04:58	0.07	2.30	111	8.608	0.072	332.00	0.61	-1.21
WAVE	25/09/2022 05:08	0.06	3.60	167	8.618	0.055	311.00	0.62	-1.20
WAVE	25/09/2022 05:18	0.07	2.30	155	8.642	0.068	292.00	0.64	-1.18
WAVE	25/09/2022 05:28	0.05	12.80	347	8.664	0.087	263.00	0.66	-1.16
WAVE	25/09/2022 05:38	0.18	9.10	135	8.721	0.082	269.00	0.72	-1.10
WAVE	25/09/2022 05:48	0.07	9.10	7	8.745	0.12	295.00	0.74	-1.08
WAVE	25/09/2022 05:58	0.06	10.70	315	8.798	0.145	286.00	0.80	-1.02
WAVE	25/09/2022 06:08	0.06	2.30	131	8.841	0.16	272.00	0.84	-0.98
WAVE	25/09/2022 06:18	0.06	6.40	169	8.899	0.193	270.00	0.90	-0.92
WAVE	25/09/2022 06:28	0.05	5.30	87	8.979	0.228	269.00	0.98	-0.84
WAVE	25/09/2022 06:38	0.02	16.00	127	9.057	0.29	263.00	1.06	-0.76
WAVE	25/09/2022 06:48	0.08	2.50	103	9.143	0.34	261.00	1.14	-0.68
WAVE	25/09/2022 06:58	0.11	3.00	115	9.227	0.407	256.00	1.23	-0.59
WAVE	25/09/2022 07:08	0.04	12.80	169	9.312	0.413	262.00	1.31	-0.51
WAVE	25/09/2022 07:18	0.10	3.20	291	9.388	0.397	257.00	1.39	-0.43
WAVE	25/09/2022 07:28	0.11	2.20	9	9.478	0.318	259.00	1.48	-0.34
WAVE	25/09/2022 07:38	0.07	2.70	331	9.554	0.296	260.00	1.55	-0.27
WAVE	25/09/2022 07:48	0.07	2.60	119	9.613	0.252	261.00	1.61	-0.21
WAVE	25/09/2022 07:58	0.06	9.10	251	9.698	0.242	262.00	1.70	-0.12
WAVE	25/09/2022 08:08	0.10	3.00	287	9.775	0.238	258.00	1.78	-0.04
WAVE	25/09/2022 08:42	0.47	9.10	357	9.988	0.016	263.00	1.99	0.17
WAVE	25/09/2022 08:52	0.14	2.30	27	10.049	0.048	231.00	2.05	0.23
WAVE	25/09/2022 09:02	0.09	2.50	275	10.104	0.014	8.00	2.10	0.28
WAVE	25/09/2022 09:35	0.02	12.80	255	10.319	0.066	19.00	2.32	0.50
WAVE	25/09/2022 09:45	0.09	2.80	327	10.374	0.092	282.00	2.37	0.55
WAVE	25/09/2022 09:55	0.11	2.70	111	10.423	0.118	274.00	2.42	0.60
WAVE	25/09/2022 10:28	0.02	12.80	99	10.594	0.043	145.00	2.59	0.77
WAVE	25/09/2022 10:38	0.05	3.20	275	10.642	0.118	258.00	2.64	0.82
WAVE	25/09/2022 10:48	0.14	3.20	113	10.67	0.08	257.00	2.67	0.85
WAVE	25/09/2022 10:58	0.05	3.00	255	10.694	0.009	89.00	2.69	0.87
WAVE	25/09/2022 11:08	0.20	2.50	132	10.734	0.034	84.00	2.73	0.91
WAVE	25/09/2022 11:18	0.06	16.00	223	10.744	0.072	123.00	2.74	0.92
WAVE	25/09/2022 11:28	0.09	3.80	91	10.77	0.214	57.00	2.77	0.95
WAVE	25/09/2022 12:01	0.03	10.70	75	10.719	0.547	73.00	2.72	0.90
WAVE	25/09/2022 12:11	0.03	9.10	75	10.691	0.304	68.00	2.69	0.87
WAVE	25/09/2022 12:45	0.03	12.80	295	10.566	0.665	73.00	2.57	0.75
WAVE	25/09/2022 12:55	0.22	2.70	297	10.527	0.384	77.00	2.53	0.71
WAVE	25/09/2022 13:05	0.05	3.20	195	10.486	0.396	78.00	2.49	0.67
WAVE	25/09/2022 13:15	0.02	16.00	147	10.431	0.397	78.00	2.43	0.61
WAVE	25/09/2022 13:48	0.37	12.80	243	10.214	0.363	91.00	2.21	0.39
WAVE	25/09/2022 13:58	0.06	10.70	59	10.134	0.287	93.00	2.13	0.31
WAVE	25/09/2022 14:08	0.08	3.00	99	10.064	0.324	90.00	2.06	0.24
WAVE	25/09/2022 14:41	0.17	9.10	331	9.8	0.252	63.00	1.80	-0.02
WAVE	25/09/2022 14:51	0.15	2.90	117	9.705	0.341	69.00	1.71	-0.12
WAVE	25/09/2022 15:01	0.09	2.10	83	9.61	0.336	74.00	1.61	-0.21
WAVE	25/09/2022 15:11	0.06	10.70	103	9.53	0.358	73.00	1.53	-0.29
WAVE	25/09/2022 15:21	0.08	3.20	139	9.453	0.318	76.00	1.45	-0.37

Name	Date Time	Significant Height(m)	Peak Time(sec)	Peak Direction (degree)	ADCP Depth(m)	Current Speed(m/s)	Current Direction (degree)	water level reference to CD	water level reference to 1.82 SHD
WAVE	25/09/2022 15:31	0.09	2.90	69	9.372	0.288	78.00	1.37	-0.45
WAVE	25/09/2022 16:04	0.03	9.10	219	9.133	0.162	68.00	1.13	-0.69
WAVE	25/09/2022 16:14	0.09	3.20	87	9.083	0.139	57.00	1.08	-0.74
WAVE	25/09/2022 16:24	0.16	3.80	119	9.061	0.114	69.00	1.06	-0.76
WAVE	25/09/2022 16:58	0.23	2.90	271	8.985	0.094	6.00	0.98	-0.84
WAVE	25/09/2022 17:08	0.15	3.00	116	9.002	0.089	356.00	1.00	-0.82
WAVE	25/09/2022 17:18	0.22	3.20	299	9.032	0.069	322.00	1.03	-0.79
WAVE	25/09/2022 17:28	0.14	2.40	99	9.05	0.065	287.00	1.05	-0.77
WAVE	25/09/2022 17:38	0.16	3.20	109	9.091	0.094	297.00	1.09	-0.73
WAVE	25/09/2022 18:11	0.04	21.30	307	9.254	0.157	294.00	1.25	-0.57
WAVE	25/09/2022 18:21	0.22	3.80	105	9.294	0.177	269.00	1.29	-0.53
WAVE	25/09/2022 18:31	0.07	2.50	127	9.363	0.163	279.00	1.36	-0.46
WAVE	25/09/2022 18:41	0.14	3.60	280	9.42	0.134	283.00	1.42	-0.40
WAVE	25/09/2022 18:51	0.06	9.10	11	9.482	0.125	273.00	1.48	-0.34
WAVE	25/09/2022 19:01	0.09	2.80	116	9.525	0.129	278.00	1.53	-0.30
WAVE	25/09/2022 19:11	0.05	4.60	83	9.576	0.121	254.00	1.58	-0.24
WAVE	25/09/2022 19:21	0.07	2.30	111	9.638	0.095	278.00	1.64	-0.18
WAVE	25/09/2022 19:31	0.04	9.10	87	9.699	0.128	252.00	1.70	-0.12
WAVE	25/09/2022 19:41	0.23	2.10	77	9.761	0.111	244.00	1.76	-0.06
WAVE	25/09/2022 19:51	0.04	21.30	169	9.825	0.106	238.00	1.83	0.00
WAVE	25/09/2022 20:01	0.04	10.70	103	9.872	0.118	238.00	1.87	0.05
WAVE	25/09/2022 20:11	0.08	2.50	103	9.948	0.092	253.00	1.95	0.13
WAVE	25/09/2022 20:21	0.07	2.30	35	10.023	0.124	245.00	2.02	0.20
WAVE	25/09/2022 20:31	0.05	3.80	103	10.1	0.198	251.00	2.10	0.28
WAVE	25/09/2022 20:41	0.03	21.30	219	10.151	0.244	250.00	2.15	0.33
WAVE	25/09/2022 20:51	0.10	2.20	95	10.25	0.217	260.00	2.25	0.43
WAVE	25/09/2022 21:01	0.05	12.80	99	10.335	0.274	252.00	2.34	0.52
WAVE	25/09/2022 21:11	0.04	4.00	83	10.409	0.217	253.00	2.41	0.59
WAVE	25/09/2022 21:21	0.07	2.50	167	10.488	0.254	251.00	2.49	0.67
WAVE	25/09/2022 21:31	0.08	2.50	179	10.568	0.293	254.00	2.57	0.75
WAVE	25/09/2022 21:41	0.06	7.10	27	10.643	0.238	254.00	2.64	0.82
WAVE	25/09/2022 21:51	0.06	9.10	151	10.713	0.241	252.00	2.71	0.89
WAVE	25/09/2022 22:01	0.07	16.00	7	10.777	0.211	246.00	2.78	0.96
WAVE	25/09/2022 22:11	0.05	8.00	23	10.831	0.291	239.00	2.83	1.01
WAVE	25/09/2022 22:21	0.08	2.70	223	10.888	0.269	242.00	2.89	1.07
WAVE	25/09/2022 22:31	0.05	9.10	51	10.946	0.248	230.00	2.95	1.13
WAVE	25/09/2022 22:41	0.05	12.80	327	10.995	0.198	237.00	3.00	1.18
WAVE	25/09/2022 22:51	0.04	21.30	39	11.043	0.17	226.00	3.04	1.22
WAVE	25/09/2022 23:01	0.15	3.40	107	11.07	0.206	219.00	3.07	1.25
WAVE	25/09/2022 23:34	0.04	12.80	111	11.105	0.094	68.00	3.11	1.29
WAVE	25/09/2022 23:44	0.07	16.00	295	11.07	0.15	92.00	3.07	1.25
WAVE	25/09/2022 23:54	0.04	10.70	55	11.054	0.165	78.00	3.05	1.23
WAVE	26/09/2022 00:04	0.05	2.60	139	11.036	0.206	79.00	3.04	1.22
WAVE	26/09/2022 00:14	0.06	3.00	83	10.995	0.256	66.00	3.00	1.18
WAVE	26/09/2022 00:47	0.06	3.60	93	10.818	0.502	76.00	2.82	1.00
WAVE	26/09/2022 00:57	0.08	8.00	79	10.754	0.372	70.00	2.75	0.93
WAVE	26/09/2022 01:07	0.06	9.10	347	10.685	0.384	73.00	2.69	0.87
WAVE	26/09/2022 01:17	0.06	9.10	11	10.602	0.397	73.00	2.60	0.78
WAVE	26/09/2022 01:51	0.06	21.30	187	10.292	0.395	58.00	2.29	0.47
WAVE	26/09/2022 02:24	0.05	9.10	95	9.951	0.291	78.00	1.95	0.13
WAVE	11/11/2022 14:34	0.05	4.00	142	10.333	0.37	69.00	2.53	0.71
WAVE	11/11/2022 14:44	0.11	4.00	82	10.244	0.361	65.00	2.44	0.62
WAVE	11/11/2022 14:54	0.14	2.50	252	10.146	0.331	75.00	2.35	0.53
WAVE	11/11/2022 15:04	0.24	9.10	266	10.055	0.368	67.00	2.26	0.44
WAVE	11/11/2022 15:14	0.16	2.10	238	9.929	0.392	82.00	2.13	0.31
WAVE	11/11/2022 15:24	0.11	2.70	240	9.827	0.374	76.00	2.03	0.21
WAVE	11/11/2022 15:34	0.07	12.80	166	9.717	0.293	74.00	1.92	0.10
WAVE	11/11/2022 15:44	0.34	16.00	98	9.643	0.318	77.00	1.84	0.02
WAVE	11/11/2022 15:54	0.07	7.10	30	9.517	0.323	82.00	1.72	-0.10
WAVE	11/11/2022 16:04	0.07	9.10	306	9.415	0.304	80.00	1.62	-0.21
WAVE	11/11/2022 16:14	0.09	2.90	108	9.308	0.262	81.00	1.51	-0.31
WAVE	11/11/2022 16:24	0.08	4.30	56	9.182	0.3	76.00	1.38	-0.44
WAVE	11/11/2022 16:34	0.06	3.60	28	9.101	0.202	72.00	1.30	-0.52
WAVE	11/11/2022 16:44	0.08	3.40	98	8.994	0.125	79.00	1.19	-0.63

Name	Date Time	Significant Height(m)	Peak Time(sec)	Peak Direction (degree)	ADCP Depth(m)	Current Speed(m/s)	Current Direction (degree)	water level reference to CD	water level reference to 1.82 SHD
WAVE	11/11/2022 16:54	0.15	2.80	182	8.915	0.14	99.00	1.12	-0.71
WAVE	11/11/2022 17:04	0.14	3.00	82	8.832	0.12	76.00	1.03	-0.79
WAVE	11/11/2022 17:14	0.52	9.10	72	8.792	0.083	48.00	0.99	-0.83
WAVE	11/11/2022 17:24	0.15	2.90	214	8.699	0.015	13.00	0.90	-0.92
WAVE	11/11/2022 17:34	0.03	9.10	350	8.643	0.064	0.00	0.84	-0.98
WAVE	11/11/2022 17:44	0.04	12.80	26	8.6	0.114	334.00	0.80	-1.02
WAVE	11/11/2022 17:54	0.03	10.70	28	8.564	0.074	304.00	0.76	-1.06
WAVE	11/11/2022 18:04	0.07	3.00	292	8.534	0.089	318.00	0.73	-1.09
WAVE	11/11/2022 18:14	0.04	12.80	186	8.524	0.106	271.00	0.72	-1.10
WAVE	11/11/2022 18:24	0.03	9.10	122	8.527	0.086	318.00	0.73	-1.09
WAVE	11/11/2022 18:34	0.10	3.20	86	8.524	0.075	261.00	0.72	-1.10
WAVE	11/11/2022 18:44	0.30	9.10	296	8.562	0.099	264.00	0.76	-1.06
WAVE	11/11/2022 18:54	0.07	3.00	334	8.554	0.106	251.00	0.75	-1.07
WAVE	11/11/2022 19:04	0.10	10.70	38	8.589	0.083	265.00	0.79	-1.03
WAVE	11/11/2022 19:14	0.11	2.70	114	8.607	0.09	269.00	0.81	-1.01
WAVE	11/11/2022 19:24	0.11	2.60	82	8.64	0.113	260.00	0.84	-0.98
WAVE	11/11/2022 19:34	0.20	2.80	206	8.693	0.127	258.00	0.89	-0.93
WAVE	11/11/2022 19:44	0.03	10.70	334	8.731	0.144	245.00	0.93	-0.89
WAVE	11/11/2022 19:54	0.03	9.10	262	8.787	0.185	237.00	0.99	-0.83
WAVE	11/11/2022 20:04	0.13	3.40	247	8.83	0.215	254.00	1.03	-0.79
WAVE	11/11/2022 20:14	0.05	4.90	66	8.903	0.321	253.00	1.10	-0.72
WAVE	11/11/2022 20:24	0.04	9.10	278	8.959	0.317	256.00	1.16	-0.66
WAVE	11/11/2022 20:34	0.12	2.50	146	9.02	0.283	259.00	1.22	-0.60
WAVE	11/11/2022 20:44	0.07	3.40	218	9.085	0.295	252.00	1.29	-0.53
WAVE	11/11/2022 20:54	0.06	7.10	28	9.155	0.266	254.00	1.36	-0.47
WAVE	11/11/2022 21:04	0.06	8.00	230	9.228	0.307	255.00	1.43	-0.39
WAVE	11/11/2022 21:14	0.02	10.70	314	9.303	0.361	257.00	1.50	-0.32
WAVE	11/11/2022 21:24	0.04	21.30	28	9.388	0.32	253.00	1.59	-0.23
WAVE	11/11/2022 21:34	0.05	4.90	326	9.463	0.345	253.00	1.66	-0.16
WAVE	11/11/2022 21:44	0.05	9.10	94	9.543	0.342	253.00	1.74	-0.08
WAVE	11/11/2022 21:54	0.03	9.10	28	9.613	0.346	258.00	1.81	-0.01
WAVE	11/11/2022 22:04	0.06	3.60	294	9.683	0.306	251.00	1.88	0.06
WAVE	11/11/2022 22:14	0.06	4.90	90	9.739	0.263	253.00	1.94	0.12
WAVE	11/11/2022 22:24	0.05	9.10	28	9.813	0.31	258.00	2.01	0.19
WAVE	11/11/2022 22:34	0.05	10.70	318	9.886	0.254	245.00	2.09	0.27
WAVE	11/11/2022 22:44	0.02	21.30	170	9.967	0.281	246.00	2.17	0.35
WAVE	11/11/2022 22:54	0.04	16.00	70	10.051	0.353	257.00	2.25	0.43
WAVE	11/11/2022 23:04	0.07	3.80	318	10.135	0.323	256.00	2.34	0.52
WAVE	11/11/2022 23:14	0.06	4.60	30	10.229	0.279	251.00	2.43	0.61
WAVE	11/11/2022 23:24	0.23	2.30	26	10.313	0.302	253.00	2.51	0.69
WAVE	11/11/2022 23:34	0.13	2.70	230	10.385	0.291	251.00	2.59	0.77
WAVE	11/11/2022 23:44	0.62	16.00	74	10.426	0.265	246.00	2.63	0.81
WAVE	11/11/2022 23:54	0.04	9.10	246	10.54	0.283	249.00	2.74	0.92
WAVE	12/11/2022 00:04	0.06	3.80	342	10.615	0.232	246.00	2.82	1.00
WAVE	12/11/2022 00:14	0.13	2.60	106	10.632	0.222	233.00	2.83	1.01
WAVE	12/11/2022 00:24	0.06	3.60	28	10.754	0.181	254.00	2.95	1.13
WAVE	12/11/2022 00:34	0.10	2.80	254	10.804	0.164	259.00	3.00	1.18
WAVE	12/11/2022 00:44	0.06	8.00	238	10.874	0.158	240.00	3.07	1.25
WAVE	12/11/2022 00:54	0.06	6.40	234	10.917	0.129	251.00	3.12	1.30
WAVE	12/11/2022 01:04	0.03	9.10	28	10.962	0.129	252.00	3.16	1.34
WAVE	12/11/2022 01:14	0.03	10.70	302	10.995	0.084	257.00	3.20	1.38
WAVE	12/11/2022 01:24	0.03	9.10	306	11.019	0.067	256.00	3.22	1.40
WAVE	12/11/2022 01:34	0.09	2.80	190	11.047	0.055	274.00	3.25	1.43
WAVE	12/11/2022 01:44	0.05	5.30	106	11.059	0.045	258.00	3.26	1.44
WAVE	12/11/2022 01:54	0.03	10.70	206	11.076	0.027	186.00	3.28	1.46
WAVE	12/11/2022 02:04	0.04	10.70	78	11.077	0.085	94.00	3.28	1.46
WAVE	12/11/2022 02:14	0.06	4.60	346	11.077	0.135	83.00	3.28	1.46
WAVE	12/11/2022 02:24	0.07	4.90	14	11.063	0.145	83.00	3.26	1.44
WAVE	12/11/2022 02:34	0.08	3.40	54	11.037	0.19	72.00	3.24	1.42
WAVE	12/11/2022 02:44	0.05	6.40	158	11.009	0.21	71.00	3.21	1.39
WAVE	12/11/2022 02:54	0.11	2.80	2	10.975	0.237	63.00	3.18	1.36
WAVE	12/11/2022 03:04	0.06	4.90	28	10.935	0.258	61.00	3.14	1.32
WAVE	12/11/2022 03:14	0.20	16.00	6	10.864	0.269	65.00	3.06	1.24
WAVE	12/11/2022 03:24	0.10	2.80	314	10.85	0.317	66.00	3.05	1.23

Name	Date Time	Significant Height(m)	Peak Time(sec)	Peak Direction (degree)	ADCP Depth(m)	Current Speed(m/s)	Current Direction (degree)	water level reference to CD	water level reference to 1.82 SHD
WAVE	12/11/2022 03:34	0.07	3.20	222	10.794	0.365	64.00	2.99	1.17
WAVE	12/11/2022 03:44	0.05	4.00	314	10.729	0.37	63.00	2.93	1.11
WAVE	12/11/2022 03:54	0.06	10.70	122	10.67	0.329	62.00	2.87	1.05
WAVE	12/11/2022 04:04	0.05	16.00	122	10.593	0.362	67.00	2.79	0.97
WAVE	12/11/2022 04:14	0.05	9.10	2	10.516	0.391	69.00	2.72	0.90
WAVE	12/11/2022 04:24	0.06	7.10	282	10.433	0.393	73.00	2.63	0.81
WAVE	12/11/2022 04:34	0.03	12.80	28	10.355	0.364	78.00	2.56	0.74
WAVE	12/11/2022 04:44	0.02	9.10	28	10.264	0.394	65.00	2.46	0.64
WAVE	12/11/2022 04:54	0.05	9.10	234	10.178	0.329	69.00	2.38	0.56
WAVE	12/11/2022 05:04	0.06	6.40	18	10.1	0.314	69.00	2.30	0.48
WAVE	12/11/2022 05:14	0.03	9.10	126	10.018	0.342	61.00	2.22	0.40
WAVE	12/11/2022 05:24	0.03	9.10	294	9.933	0.279	56.00	2.13	0.31
WAVE	12/11/2022 05:34	0.03	9.10	98	9.857	0.296	47.00	2.06	0.24
WAVE	12/11/2022 05:44	0.03	10.70	158	9.792	0.271	46.00	1.99	0.17
WAVE	12/11/2022 05:54	0.02	16.00	218	9.726	0.339	53.00	1.93	0.11
WAVE	12/11/2022 06:04	0.12	2.10	342	9.677	0.324	54.00	1.88	0.06
WAVE	12/11/2022 06:14	0.08	2.90	28	9.623	0.383	58.00	1.82	0.00
WAVE	12/11/2022 06:24	0.60	9.10	238	9.626	0.29	52.00	1.83	0.01
WAVE	12/11/2022 06:34	0.03	10.70	326	9.543	0.284	47.00	1.74	-0.08
WAVE	12/11/2022 06:44	0.06	3.60	282	9.533	0.288	38.00	1.73	-0.09
WAVE	12/11/2022 06:54	0.04	12.80	28	9.509	0.121	69.00	1.71	-0.11
WAVE	12/11/2022 07:04	0.12	2.50	214	9.521	0.11	57.00	1.72	-0.10
WAVE	12/11/2022 07:14	0.13	2.50	58	9.524	0.065	59.00	1.72	-0.10
WAVE	12/11/2022 07:24	0.06	4.30	118	9.534	0.022	134.00	1.73	-0.09
WAVE	12/11/2022 07:34	0.08	3.40	98	9.551	0.064	230.00	1.75	-0.07
WAVE	12/11/2022 07:44	0.16	3.00	117	9.579	0.035	266.00	1.78	-0.04
WAVE	12/11/2022 07:54	0.12	3.80	84	9.622	0.084	238.00	1.82	0.00
WAVE	12/11/2022 08:04	0.21	2.70	114	9.661	0.097	231.00	1.86	0.04
WAVE	12/11/2022 08:14	0.27	2.60	238	9.704	0.143	240.00	1.90	0.08
WAVE	12/11/2022 08:24	0.09	2.90	274	9.766	0.176	239.00	1.97	0.15
WAVE	12/11/2022 08:34	0.25	2.90	120	9.813	0.217	243.00	2.01	0.19
WAVE	12/11/2022 08:44	0.16	2.80	103	9.868	0.222	251.00	2.07	0.25
WAVE	12/11/2022 08:54	0.31	2.80	108	9.926	0.241	256.00	2.13	0.31
WAVE	12/11/2022 09:04	0.27	2.90	125	9.982	0.224	252.00	2.18	0.36
WAVE	12/11/2022 09:14	0.13	2.70	294	10.047	0.254	259.00	2.25	0.43
WAVE	12/11/2022 09:24	0.10	2.80	74	10.102	0.151	256.00	2.30	0.48
WAVE	12/11/2022 09:34	0.08	3.00	114	10.168	0.152	253.00	2.37	0.55
WAVE	12/11/2022 09:44	0.13	3.40	102	10.233	0.161	264.00	2.43	0.61
WAVE	12/11/2022 09:54	0.08	3.40	134	10.297	0.152	250.00	2.50	0.68
WAVE	12/11/2022 10:04	0.09	3.20	218	10.344	0.133	256.00	2.54	0.72
WAVE	12/11/2022 10:14	0.09	2.70	128	10.399	0.109	258.00	2.60	0.78
WAVE	12/11/2022 10:24	0.23	2.50	114	10.446	0.131	261.00	2.65	0.83
WAVE	12/11/2022 10:34	0.11	16.00	334	10.499	0.089	254.00	2.70	0.88
WAVE	12/11/2022 10:44	0.13	3.00	130	10.553	0.114	288.00	2.75	0.93
WAVE	12/11/2022 10:54	0.11	2.80	114	10.605	0.119	298.00	2.81	0.99
WAVE	12/11/2022 11:14	0.07	9.10	294	10.719	0.156	272.00	2.92	1.10
WAVE	12/11/2022 11:24	0.11	2.90	123	10.758	0.186	249.00	2.96	1.14
WAVE	12/11/2022 11:34	0.12	2.90	26	10.809	0.154	264.00	3.01	1.19
WAVE	12/11/2022 11:44	0.19	3.60	226	10.846	0.163	252.00	3.05	1.23
WAVE	12/11/2022 11:54	0.08	2.90	318	10.88	0.164	249.00	3.08	1.26
WAVE	12/11/2022 12:14	0.10	2.80	109	10.946	0.113	256.00	3.15	1.33
WAVE	12/11/2022 12:24	0.13	3.40	202	10.97	0.132	248.00	3.17	1.35
WAVE	12/11/2022 12:34	0.16	2.70	126	10.979	0.102	236.00	3.18	1.36
WAVE	12/11/2022 12:44	0.12	2.90	122	10.993	0.028	193.00	3.19	1.37
WAVE	12/11/2022 12:54	0.12	2.80	312	10.982	0.075	116.00	3.18	1.36
WAVE	12/11/2022 13:04	0.06	3.40	46	10.969	0.149	86.00	3.17	1.35
WAVE	12/11/2022 13:14	0.16	2.90	96	10.955	0.188	62.00	3.16	1.34
WAVE	12/11/2022 13:24	0.27	3.20	110	10.925	0.225	65.00	3.13	1.31
WAVE	12/11/2022 13:34	0.25	9.10	90	10.877	0.242	61.00	3.08	1.26
WAVE	12/11/2022 13:44	0.25	2.10	258	10.858	0.263	66.00	3.06	1.24
WAVE	12/11/2022 13:54	0.04	9.10	310	10.805	0.289	70.00	3.01	1.19
WAVE	12/11/2022 14:04	0.18	3.20	110	10.761	0.323	75.00	2.96	1.14
WAVE	12/11/2022 14:14	0.25	21.30	246	10.691	0.303	72.00	2.89	1.07
WAVE	12/11/2022 14:24	0.14	3.40	104	10.635	0.366	74.00	2.84	1.02

Name	Date Time	Significant Height(m)	Peak Time(sec)	Peak Direction (degree)	ADCP Depth(m)	Current Speed(m/s)	Current Direction (degree)	water level reference to CD	water level reference to 1.82 SHD
WAVE	12/11/2022 14:34	0.06	4.30	110	10.572	0.377	76.00	2.77	0.95
WAVE	12/11/2022 14:44	0.08	3.40	114	10.499	0.345	74.00	2.70	0.88
WAVE	12/11/2022 14:54	0.08	3.60	58	10.422	0.356	73.00	2.62	0.80
WAVE	12/11/2022 15:04	0.03	9.10	142	10.337	0.405	67.00	2.54	0.72
WAVE	12/11/2022 15:14	0.08	3.80	94	10.235	0.416	68.00	2.44	0.62
WAVE	12/11/2022 15:24	0.12	2.80	313	10.135	0.367	62.00	2.34	0.52
WAVE	12/11/2022 15:34	0.17	2.50	302	10.028	0.313	61.00	2.23	0.41
WAVE	12/11/2022 15:44	0.06	21.30	282	9.943	0.253	68.00	2.14	0.32
WAVE	12/11/2022 15:54	0.06	4.30	98	9.851	0.362	72.00	2.05	0.23
WAVE	12/11/2022 16:04	0.10	2.70	80	9.751	0.37	70.00	1.95	0.13
WAVE	12/11/2022 16:14	0.11	2.90	294	9.646	0.338	74.00	1.85	0.03
WAVE	12/11/2022 16:24	0.06	8.00	28	9.553	0.283	77.00	1.75	-0.07
WAVE	12/11/2022 16:34	0.07	3.00	76	9.448	0.259	79.00	1.65	-0.17
WAVE	12/11/2022 16:44	0.14	2.90	67	9.328	0.293	61.00	1.53	-0.29
WAVE	12/11/2022 16:54	0.08	3.20	122	9.235	0.246	80.00	1.44	-0.39
WAVE	12/11/2022 17:04	0.07	8.00	302	9.135	0.222	72.00	1.34	-0.49
WAVE	12/11/2022 17:14	0.11	2.90	70	9.048	0.179	59.00	1.25	-0.57
WAVE	12/11/2022 17:24	0.12	3.20	77	8.968	0.163	72.00	1.17	-0.65
WAVE	12/11/2022 17:34	0.08	3.40	110	8.893	0.182	81.00	1.09	-0.73
WAVE	12/11/2022 17:44	0.03	10.70	28	8.824	0.128	71.00	1.02	-0.80
WAVE	12/11/2022 17:54	0.10	2.80	238	8.755	0.124	75.00	0.96	-0.86
WAVE	12/11/2022 18:04	0.05	12.80	266	8.696	0.117	81.00	0.90	-0.92
WAVE	12/11/2022 18:14	0.30	3.00	129	8.643	0.081	90.00	0.84	-0.98
WAVE	12/11/2022 18:24	0.04	6.40	326	8.598	0.028	107.00	0.80	-1.02
WAVE	12/11/2022 18:54	0.15	2.80	102	8.502	0.04	16.00	0.70	-1.12
WAVE	12/11/2022 19:04	0.06	6.40	226	8.503	0.078	3.00	0.70	-1.12
WAVE	12/11/2022 19:14	0.11	3.20	98	8.496	0.061	328.00	0.70	-1.12
WAVE	12/11/2022 19:24	0.11	2.50	298	8.506	0.08	312.00	0.71	-1.11
WAVE	12/11/2022 19:34	0.06	8.00	6	8.514	0.095	314.00	0.71	-1.11
WAVE	12/11/2022 19:44	0.07	7.10	114	8.537	0.11	304.00	0.74	-1.08
WAVE	12/11/2022 19:54	0.09	2.90	122	8.554	0.106	325.00	0.75	-1.07
WAVE	12/11/2022 20:04	0.06	3.20	54	8.585	0.102	318.00	0.79	-1.04
WAVE	12/11/2022 20:14	0.03	8.00	198	8.621	0.127	289.00	0.82	-1.00
WAVE	12/11/2022 20:24	0.07	3.00	30	8.671	0.131	269.00	0.87	-0.95
WAVE	12/11/2022 20:34	0.03	21.30	266	8.74	0.168	256.00	0.94	-0.88
WAVE	12/11/2022 20:44	0.42	16.00	134	8.789	0.257	259.00	0.99	-0.83
WAVE	12/11/2022 20:54	0.11	3.20	62	8.817	0.399	263.00	1.02	-0.80
WAVE	12/11/2022 21:04	0.10	3.40	102	8.872	0.31	262.00	1.07	-0.75
WAVE	12/11/2022 21:14	0.06	6.40	290	8.932	0.265	254.00	1.13	-0.69
WAVE	12/11/2022 21:24	0.06	5.30	342	9.001	0.296	252.00	1.20	-0.62
WAVE	12/11/2022 21:34	0.04	9.10	78	9.068	0.332	261.00	1.27	-0.55
WAVE	12/11/2022 21:44	0.09	3.00	146	9.141	0.302	260.00	1.34	-0.48
WAVE	12/11/2022 21:54	0.07	3.80	114	9.219	0.278	255.00	1.42	-0.40
WAVE	12/11/2022 22:04	0.39	9.10	346	9.272	0.241	255.00	1.47	-0.35
WAVE	12/11/2022 22:14	0.18	2.30	314	9.363	0.273	258.00	1.56	-0.26
WAVE	12/11/2022 22:24	0.06	5.30	26	9.433	0.26	257.00	1.63	-0.19
WAVE	12/11/2022 22:34	0.05	9.10	162	9.506	0.255	267.00	1.71	-0.11
WAVE	12/11/2022 22:44	0.03	10.70	334	9.578	0.253	260.00	1.78	-0.04
WAVE	12/11/2022 22:54	0.14	2.20	350	9.639	0.283	256.00	1.84	0.02
WAVE	12/11/2022 23:04	0.07	2.80	82	9.708	0.351	273.00	1.91	0.09
WAVE	12/11/2022 23:14	0.07	2.70	310	9.781	0.407	271.00	1.98	0.16
WAVE	12/11/2022 23:24	0.05	8.00	270	9.849	0.387	269.00	2.05	0.23
WAVE	12/11/2022 23:34	0.06	4.30	142	9.925	0.366	260.00	2.13	0.31
WAVE	12/11/2022 23:44	0.04	6.40	22	10.005	0.35	263.00	2.21	0.39
WAVE	13/11/2022 00:04	0.17	2.30	302	10.157	0.362	264.00	2.36	0.54
WAVE	13/11/2022 00:14	0.05	12.80	334	10.246	0.305	261.00	2.45	0.63
WAVE	13/11/2022 00:24	0.05	6.40	278	10.322	0.317	258.00	2.52	0.70
WAVE	13/11/2022 00:34	0.06	3.60	90	10.393	0.324	261.00	2.59	0.77
WAVE	13/11/2022 00:54	0.06	12.80	318	10.539	0.378	263.00	2.74	0.92
WAVE	13/11/2022 01:04	0.05	6.40	110	10.6	0.308	258.00	2.80	0.98
WAVE	13/11/2022 01:14	0.05	10.70	282	10.656	0.245	256.00	2.86	1.04
WAVE	13/11/2022 01:24	0.05	16.00	258	10.708	0.19	252.00	2.91	1.09
WAVE	13/11/2022 01:34	0.12	2.50	112	10.75	0.166	250.00	2.95	1.13
WAVE	13/11/2022 01:44	0.02	10.70	334	10.796	0.129	254.00	3.00	1.18

Name	Date Time	Significant Height(m)	Peak Time(sec)	Peak Direction (degree)	ADCP Depth(m)	Current Speed(m/s)	Current Direction (degree)	water level reference to CD	water level reference to 1.82 SHD
WAVE	13/11/2022 01:54	0.24	9.10	230	10.751	0.065	255.00	2.95	1.13
WAVE	13/11/2022 02:04	0.08	3.00	350	10.852	0.048	281.00	3.05	1.23
WAVE	13/11/2022 02:14	0.06	4.90	170	10.878	0.044	244.00	3.08	1.26
WAVE	13/11/2022 02:24	0.10	3.40	126	10.89	0.024	226.00	3.09	1.27
WAVE	13/11/2022 02:34	0.07	3.60	230	10.894	0.067	128.00	3.09	1.27
WAVE	13/11/2022 02:44	0.03	9.10	28	10.899	0.038	77.00	3.10	1.28
WAVE	13/11/2022 02:54	0.07	21.30	28	10.893	0.104	92.00	3.09	1.27
WAVE	13/11/2022 03:04	0.06	9.10	226	10.882	0.143	92.00	3.08	1.26
WAVE	13/11/2022 03:14	0.03	9.10	318	10.862	0.188	87.00	3.06	1.24
WAVE	13/11/2022 03:24	0.06	16.00	14	10.84	0.189	75.00	3.04	1.22
WAVE	13/11/2022 03:34	0.06	5.30	186	10.808	0.209	72.00	3.01	1.19
WAVE	13/11/2022 03:44	0.08	2.80	206	10.783	0.222	66.00	2.98	1.16
WAVE	13/11/2022 03:54	0.06	9.10	154	10.747	0.272	76.00	2.95	1.13
WAVE	13/11/2022 04:04	0.03	9.10	242	10.704	0.25	69.00	2.90	1.08
WAVE	13/11/2022 04:14	0.15	21.30	242	10.661	0.266	70.00	2.86	1.04
WAVE	13/11/2022 04:24	0.06	9.10	322	10.608	0.289	71.00	2.81	0.99
WAVE	13/11/2022 04:34	0.08	16.00	28	10.552	0.276	61.00	2.75	0.93
WAVE	13/11/2022 04:44	0.06	21.30	202	10.487	0.275	53.00	2.69	0.87
WAVE	13/11/2022 04:54	0.02	9.10	318	10.427	0.336	57.00	2.63	0.81
WAVE	13/11/2022 05:04	0.02	16.00	326	10.359	0.343	66.00	2.56	0.74
WAVE	13/11/2022 05:24	0.04	9.10	142	10.212	0.383	59.00	2.41	0.59
WAVE	13/11/2022 05:34	0.10	3.00	194	10.145	0.348	68.00	2.35	0.53
WAVE	13/11/2022 05:44	0.02	9.10	158	10.062	0.364	63.00	2.26	0.44
WAVE	13/11/2022 05:54	0.04	16.00	214	10	0.394	56.00	2.20	0.38
WAVE	13/11/2022 06:04	0.06	6.40	178	9.929	0.408	51.00	2.13	0.31
WAVE	13/11/2022 06:14	0.12	2.90	198	9.868	0.386	56.00	2.07	0.25
WAVE	13/11/2022 06:24	0.06	5.80	122	9.819	0.336	72.00	2.02	0.20
WAVE	13/11/2022 06:34	0.05	16.00	26	9.777	0.4	56.00	1.98	0.16
WAVE	13/11/2022 06:44	0.05	4.00	114	9.734	0.375	55.00	1.93	0.11
WAVE	13/11/2022 06:54	0.06	4.30	216	9.697	0.326	56.00	1.90	0.08
WAVE	13/11/2022 07:04	0.05	4.30	322	9.674	0.315	62.00	1.87	0.05
WAVE	13/11/2022 07:14	0.04	9.10	306	9.66	0.256	79.00	1.86	0.04
WAVE	13/11/2022 07:24	0.07	7.10	86	9.644	0.215	79.00	1.84	0.02
WAVE	13/11/2022 07:34	0.09	2.90	90	9.644	0.177	83.00	1.84	0.02
WAVE	13/11/2022 07:44	0.08	3.40	250	9.638	0.109	112.00	1.84	0.02
WAVE	13/11/2022 07:54	0.05	6.40	178	9.657	0.094	135.00	1.86	0.04
WAVE	13/11/2022 08:04	0.10	2.40	230	9.682	0.101	184.00	1.88	0.06
WAVE	13/11/2022 08:14	0.18	2.90	106	9.72	0.129	210.00	1.92	0.10
WAVE	13/11/2022 08:24	0.11	3.00	262	9.746	0.165	224.00	1.95	0.13
WAVE	13/11/2022 08:34	0.03	9.10	206	9.794	0.208	239.00	1.99	0.17
WAVE	13/11/2022 08:44	0.06	3.60	126	9.837	0.24	242.00	2.04	0.22
WAVE	13/11/2022 08:54	0.07	3.00	112	9.882	0.261	238.00	2.08	0.26
WAVE	13/11/2022 09:04	0.17	16.00	28	9.954	0.301	243.00	2.15	0.33
WAVE	13/11/2022 09:14	0.34	16.00	44	9.992	0.29	249.00	2.19	0.37
WAVE	13/11/2022 09:24	0.10	2.90	86	10.006	0.305	269.00	2.21	0.39
WAVE	13/11/2022 09:34	0.12	3.40	114	10.061	0.199	259.00	2.26	0.44
WAVE	13/11/2022 09:44	0.03	10.70	286	10.1	0.17	261.00	2.30	0.48
WAVE	13/11/2022 09:54	0.02	21.30	154	10.148	0.167	276.00	2.35	0.53
WAVE	13/11/2022 10:04	0.30	2.80	128	10.2	0.146	283.00	2.40	0.58
WAVE	13/11/2022 10:14	0.06	8.00	82	10.233	0.122	285.00	2.43	0.61
WAVE	13/11/2022 10:24	0.22	2.90	103	10.288	0.118	286.00	2.49	0.67
WAVE	13/11/2022 10:34	0.07	4.00	314	10.327	0.088	270.00	2.53	0.71
WAVE	13/11/2022 10:44	0.06	12.80	6	10.361	0.1	291.00	2.56	0.74
WAVE	13/11/2022 10:54	0.07	21.30	330	10.401	0.07	278.00	2.60	0.78
WAVE	13/11/2022 11:04	0.14	2.70	114	10.439	0.074	256.00	2.64	0.82
WAVE	13/11/2022 11:14	0.19	2.60	112	10.492	0.073	252.00	2.69	0.87
WAVE	13/11/2022 11:24	0.11	2.90	102	10.532	0.094	269.00	2.73	0.91
WAVE	13/11/2022 11:34	0.05	4.90	278	10.578	0.113	278.00	2.78	0.96
WAVE	13/11/2022 11:44	0.22	2.70	105	10.623	0.11	278.00	2.82	1.00
WAVE	13/11/2022 11:54	0.11	2.80	150	10.663	0.092	274.00	2.86	1.04
WAVE	13/11/2022 12:04	0.17	2.70	143	10.708	0.12	264.00	2.91	1.09
WAVE	13/11/2022 12:14	0.12	3.00	115	10.748	0.16	281.00	2.95	1.13
WAVE	13/11/2022 12:24	0.05	12.80	226	10.778	0.101	259.00	2.98	1.16
WAVE	13/11/2022 12:34	0.17	2.80	93	10.811	0.1	252.00	3.01	1.19

Name	Date Time	Significant Height(m)	Peak Time(sec)	Peak Direction (degree)	ADCP Depth(m)	Current Speed(m/s)	Current Direction (degree)	water level reference to CD	water level reference to 1.82 SHD
WAVE	13/11/2022 12:54	0.12	2.60	118	10.861	0.073	271.00	3.06	1.24
WAVE	13/11/2022 13:04	0.13	3.00	109	10.885	0.079	299.00	3.09	1.27
WAVE	13/11/2022 13:14	0.03	21.30	286	10.884	0.036	346.00	3.08	1.26
WAVE	13/11/2022 13:24	0.13	3.20	97	10.89	0.051	35.00	3.09	1.27
WAVE	13/11/2022 13:34	0.17	2.80	118	10.888	0.056	43.00	3.09	1.27
WAVE	13/11/2022 13:44	0.06	3.80	28	10.878	0.103	64.00	3.08	1.26
WAVE	13/11/2022 13:54	0.06	10.70	28	10.858	0.156	67.00	3.06	1.24
WAVE	13/11/2022 14:04	0.10	2.70	114	10.833	0.207	74.00	3.03	1.21
WAVE	13/11/2022 14:14	0.14	2.90	110	10.797	0.204	79.00	3.00	1.18
WAVE	13/11/2022 14:24	0.13	2.80	290	10.761	0.208	72.00	2.96	1.14
WAVE	13/11/2022 14:34	0.17	2.70	82	10.715	0.262	85.00	2.92	1.10
WAVE	13/11/2022 14:44	0.15	2.60	291	10.662	0.298	70.00	2.86	1.04
WAVE	13/11/2022 14:54	0.20	3.40	105	10.606	0.322	68.00	2.81	0.99
WAVE	13/11/2022 15:04	0.15	3.00	98	10.551	0.343	67.00	2.75	0.93
WAVE	13/11/2022 15:14	0.08	3.20	82	10.479	0.37	72.00	2.68	0.86
WAVE	13/11/2022 15:24	0.07	2.90	58	10.41	0.396	67.00	2.61	0.79
WAVE	13/11/2022 15:34	0.08	2.80	134	10.333	0.424	65.00	2.53	0.71
WAVE	13/11/2022 15:44	0.07	3.00	90	10.236	0.421	65.00	2.44	0.62
WAVE	13/11/2022 15:54	0.60	16.00	274	10.098	0.394	67.00	2.30	0.48
WAVE	13/11/2022 16:04	0.11	3.20	100	10.048	0.416	71.00	2.25	0.43
WAVE	13/11/2022 16:14	0.17	2.90	297	9.957	0.371	74.00	2.16	0.34
WAVE	13/11/2022 16:24	0.11	3.00	94	9.862	0.465	69.00	2.06	0.24
WAVE	13/11/2022 16:34	0.17	2.70	122	9.766	0.492	72.00	1.97	0.15
WAVE	13/11/2022 16:44	0.12	2.90	86	9.665	0.482	72.00	1.87	0.04
WAVE	13/11/2022 16:54	0.07	3.00	66	9.554	0.507	64.00	1.75	-0.07
WAVE	13/11/2022 17:04	0.25	4.00	88	9.455	0.556	63.00	1.66	-0.17
WAVE	13/11/2022 17:14	0.23	2.70	296	9.343	0.564	55.00	1.54	-0.28
WAVE	13/11/2022 17:24	0.09	3.40	214	9.243	0.363	63.00	1.44	-0.38
WAVE	13/11/2022 17:34	0.05	12.80	254	9.143	0.357	56.00	1.34	-0.48
WAVE	13/11/2022 17:44	0.10	7.10	270	9.048	0.336	65.00	1.25	-0.57
WAVE	13/11/2022 17:54	0.02	9.10	28	8.96	0.186	66.00	1.16	-0.66
WAVE	13/11/2022 18:04	0.04	12.80	182	8.886	0.205	64.00	1.09	-0.73
WAVE	13/11/2022 18:14	0.15	2.70	130	8.818	0.151	65.00	1.02	-0.80
WAVE	13/11/2022 18:24	0.03	16.00	28	8.76	0.115	82.00	0.96	-0.86
WAVE	13/11/2022 18:34	0.42	10.70	98	8.763	0.091	77.00	0.96	-0.86
WAVE	13/11/2022 18:44	0.26	4.00	99	8.643	0.024	114.00	0.84	-0.98
WAVE	13/11/2022 18:54	0.07	3.40	142	8.61	0.035	122.00	0.81	-1.01
WAVE	13/11/2022 19:04	0.05	10.70	294	8.583	0.029	24.00	0.78	-1.04
WAVE	13/11/2022 19:14	0.10	3.00	98	8.55	0.04	301.00	0.75	-1.07
WAVE	13/11/2022 19:24	0.20	3.40	92	8.538	0.065	314.00	0.74	-1.08
WAVE	13/11/2022 19:34	0.07	3.60	334	8.528	0.062	310.00	0.73	-1.09
WAVE	13/11/2022 19:44	0.09	4.00	134	8.534	0.075	284.00	0.73	-1.09
WAVE	13/11/2022 20:04	0.10	3.40	106	8.55	0.12	312.00	0.75	-1.07
WAVE	13/11/2022 20:14	0.06	3.80	28	8.561	0.083	317.00	0.76	-1.06
WAVE	13/11/2022 20:24	0.04	5.30	238	8.598	0.054	322.00	0.80	-1.02
WAVE	13/11/2022 20:34	0.03	9.10	130	8.606	0.076	305.00	0.81	-1.01
WAVE	13/11/2022 20:44	0.03	12.80	238	8.644	0.07	278.00	0.84	-0.98
WAVE	13/11/2022 20:54	0.05	16.00	274	8.667	0.159	255.00	0.87	-0.95
WAVE	13/11/2022 21:04	0.03	12.80	174	8.715	0.11	239.00	0.92	-0.91
WAVE	13/11/2022 21:14	0.11	2.40	278	8.747	0.129	237.00	0.95	-0.87
WAVE	13/11/2022 21:24	0.07	5.30	10	8.798	0.222	241.00	1.00	-0.82
WAVE	13/11/2022 21:34	0.02	12.80	314	8.844	0.227	251.00	1.04	-0.78
WAVE	13/11/2022 21:44	0.06	3.60	54	8.892	0.244	255.00	1.09	-0.73
WAVE	13/11/2022 21:54	0.07	3.00	28	8.957	0.268	241.00	1.16	-0.66
WAVE	13/11/2022 22:04	0.41	9.10	198	9.038	0.257	249.00	1.24	-0.58
WAVE	13/11/2022 22:14	0.06	3.80	28	9.079	0.268	248.00	1.28	-0.54
WAVE	13/11/2022 22:24	0.04	9.10	330	9.141	0.271	259.00	1.34	-0.48
WAVE	13/11/2022 22:34	0.05	5.80	28	9.22	0.269	259.00	1.42	-0.40
WAVE	13/11/2022 22:44	0.03	10.70	138	9.288	0.264	263.00	1.49	-0.33
WAVE	13/11/2022 22:54	0.03	12.80	298	9.356	0.288	259.00	1.56	-0.26
WAVE	13/11/2022 23:04	0.09	2.70	298	9.421	0.371	259.00	1.62	-0.20
WAVE	13/11/2022 23:14	0.10	2.30	28	9.492	0.314	260.00	1.69	-0.13
WAVE	13/11/2022 23:24	0.44	16.00	86	9.526	0.275	263.00	1.73	-0.09
WAVE	13/11/2022 23:34	0.07	3.80	166	9.623	0.252	269.00	1.82	0.00

Name	Date Time	Significant Height(m)	Peak Time(sec)	Peak Direction (degree)	ADCP Depth(m)	Current Speed(m/s)	Current Direction (degree)	water level reference to CD	water level reference to 1.82 SHD
WAVE	13/11/2022 23:54	0.07	2.80	306	9.744	0.283	275.00	1.94	0.12
WAVE	14/11/2022 00:04	0.06	7.10	302	9.808	0.283	277.00	2.01	0.19
WAVE	14/11/2022 00:14	0.03	10.70	326	9.874	0.262	277.00	2.07	0.25
WAVE	14/11/2022 00:24	0.06	6.40	226	9.942	0.255	277.00	2.14	0.32
WAVE	14/11/2022 00:44	0.06	3.80	310	10.077	0.285	271.00	2.28	0.46
WAVE	14/11/2022 01:04	0.04	8.00	28	10.224	0.328	265.00	2.42	0.60
WAVE	14/11/2022 01:14	0.03	10.70	126	10.299	0.339	261.00	2.50	0.68
WAVE	14/11/2022 01:24	0.07	9.10	314	10.37	0.342	256.00	2.57	0.75
WAVE	14/11/2022 01:34	0.14	2.10	166	10.442	0.282	255.00	2.64	0.82
WAVE	14/11/2022 01:44	0.03	12.80	282	10.492	0.245	249.00	2.69	0.87
WAVE	14/11/2022 01:54	0.03	16.00	246	10.543	0.191	231.00	2.74	0.92
WAVE	14/11/2022 02:04	0.03	12.80	294	10.594	0.184	248.00	2.79	0.97
WAVE	14/11/2022 02:14	0.04	10.70	270	10.629	0.153	228.00	2.83	1.01
WAVE	14/11/2022 02:24	0.07	3.40	122	10.664	0.087	235.00	2.86	1.04
WAVE	14/11/2022 02:34	0.03	12.80	226	10.7	0.064	183.00	2.90	1.08
WAVE	14/11/2022 02:54	0.04	10.70	282	10.732	0.1	90.00	2.93	1.11
WAVE	14/11/2022 03:04	0.09	3.00	28	10.747	0.16	89.00	2.95	1.13
WAVE	14/11/2022 03:14	0.05	12.80	28	10.752	0.193	63.00	2.95	1.13
WAVE	14/11/2022 03:24	0.06	5.30	126	10.742	0.172	53.00	2.94	1.12
WAVE	14/11/2022 03:34	0.09	2.70	28	10.731	0.188	52.00	2.93	1.11
WAVE	14/11/2022 03:44	0.05	8.00	62	10.705	0.2	60.00	2.91	1.09
WAVE	14/11/2022 03:54	0.03	10.70	302	10.681	0.181	62.00	2.88	1.06
WAVE	14/11/2022 04:14	0.05	9.10	82	10.631	0.161	58.00	2.83	1.01
WAVE	14/11/2022 04:24	0.03	10.70	22	10.6	0.169	61.00	2.80	0.98
WAVE	14/11/2022 04:34	0.05	3.40	318	10.57	0.16	57.00	2.77	0.95
WAVE	14/11/2022 04:44	0.11	2.60	241	10.533	0.215	51.00	2.73	0.91
WAVE	14/11/2022 04:54	0.06	3.60	206	10.502	0.212	60.00	2.70	0.88
WAVE	14/11/2022 05:04	0.06	5.30	58	10.453	0.227	64.00	2.65	0.83
WAVE	14/11/2022 05:14	0.07	3.80	106	10.406	0.231	66.00	2.61	0.79
WAVE	14/11/2022 05:24	0.08	3.80	90	10.348	0.264	64.00	2.55	0.73
WAVE	14/11/2022 05:34	0.04	10.70	262	10.294	0.321	57.00	2.49	0.67
WAVE	14/11/2022 05:44	0.03	9.10	350	10.234	0.296	73.00	2.43	0.61
WAVE	14/11/2022 05:54	0.07	3.00	314	10.171	0.326	71.00	2.37	0.55
WAVE	14/11/2022 06:04	0.11	9.10	206	10.098	0.348	75.00	2.30	0.48
WAVE	14/11/2022 06:14	0.03	9.10	28	10.032	0.372	64.00	2.23	0.41
WAVE	14/11/2022 06:24	0.06	5.30	294	9.965	0.418	74.00	2.17	0.35
WAVE	14/11/2022 06:34	0.08	4.00	106	9.898	0.412	71.00	2.10	0.28
WAVE	14/11/2022 06:44	0.04	9.10	326	9.836	0.412	72.00	2.04	0.22
WAVE	14/11/2022 06:54	0.09	3.80	66	9.79	0.374	73.00	1.99	0.17
WAVE	14/11/2022 07:04	0.11	2.80	300	9.749	0.373	70.00	1.95	0.13
WAVE	14/11/2022 07:14	0.07	4.30	66	9.703	0.337	67.00	1.90	0.08
WAVE	14/11/2022 07:24	0.10	2.80	28	9.673	0.268	75.00	1.87	0.05
WAVE	14/11/2022 07:34	0.04	9.10	246	9.647	0.156	85.00	1.85	0.03
WAVE	14/11/2022 07:44	0.09	2.90	82	9.622	0.16	78.00	1.82	0.00
WAVE	14/11/2022 07:54	0.13	3.60	122	9.61	0.213	70.00	1.81	-0.01
WAVE	14/11/2022 08:04	0.09	3.00	92	9.61	0.158	81.00	1.81	-0.01
WAVE	14/11/2022 08:14	0.33	2.70	274	9.61	0.112	93.00	1.81	-0.01
WAVE	14/11/2022 08:24	0.03	10.70	98	9.628	0.089	87.00	1.83	0.01
WAVE	14/11/2022 08:34	0.17	3.80	110	9.656	0.045	94.00	1.86	0.04
WAVE	14/11/2022 08:44	0.09	2.80	100	9.68	0.085	226.00	1.88	0.06
WAVE	14/11/2022 08:54	0.10	3.20	250	9.704	0.108	244.00	1.90	0.08
WAVE	14/11/2022 09:04	0.03	9.10	206	9.736	0.197	245.00	1.94	0.12
WAVE	14/11/2022 09:14	0.24	2.90	121	9.772	0.131	251.00	1.97	0.15
WAVE	14/11/2022 09:24	0.20	2.80	122	9.81	0.183	254.00	2.01	0.19
WAVE	14/11/2022 09:34	0.15	3.00	115	9.849	0.227	255.00	2.05	0.23
WAVE	14/11/2022 09:44	0.12	2.80	96	9.885	0.208	273.00	2.09	0.27
WAVE	14/11/2022 09:54	0.26	2.90	154	9.93	0.184	270.00	2.13	0.31
WAVE	14/11/2022 10:04	0.11	3.00	226	9.969	0.209	263.00	2.17	0.35
WAVE	14/11/2022 10:14	0.03	12.80	242	10.008	0.183	278.00	2.21	0.39
WAVE	14/11/2022 10:24	0.03	21.30	130	10.043	0.195	274.00	2.24	0.42
WAVE	14/11/2022 10:34	0.07	3.80	282	10.078	0.185	290.00	2.28	0.46
WAVE	14/11/2022 10:44	0.19	2.10	170	10.124	0.174	290.00	2.32	0.50
WAVE	14/11/2022 10:54	0.14	2.80	110	10.175	0.123	284.00	2.38	0.56
WAVE	14/11/2022 11:04	0.08	3.40	54	10.213	0.151	256.00	2.41	0.59

Name	Date Time	Significant Height(m)	Peak Time(sec)	Peak Direction (degree)	ADCP Depth(m)	Current Speed(m/s)	Current Direction (degree)	water level reference to CD	water level reference to 1.82 SHD
WAVE	14/11/2022 11:14	0.13	3.00	62	10.288	0.173	262.00	2.49	0.67
WAVE	14/11/2022 11:24	0.07	3.40	218	10.301	0.136	261.00	2.50	0.68
WAVE	14/11/2022 11:34	0.03	9.10	90	10.348	0.135	251.00	2.55	0.73
WAVE	14/11/2022 11:44	0.05	8.00	202	10.4	0.116	258.00	2.60	0.78
WAVE	14/11/2022 11:54	0.13	2.70	114	10.431	0.134	232.00	2.63	0.81
WAVE	14/11/2022 12:04	0.20	2.80	286	10.478	0.139	261.00	2.68	0.86
WAVE	14/11/2022 12:14	0.03	10.70	298	10.521	0.152	262.00	2.72	0.90
WAVE	14/11/2022 12:24	0.09	2.90	110	10.565	0.107	248.00	2.77	0.95
WAVE	14/11/2022 12:34	0.18	3.60	198	10.608	0.127	262.00	2.81	0.99
WAVE	14/11/2022 12:44	0.04	21.30	170	10.643	0.11	270.00	2.84	1.02
WAVE	14/11/2022 12:54	0.15	2.20	354	10.682	0.089	273.00	2.88	1.06
WAVE	14/11/2022 13:04	0.03	9.10	98	10.707	0.074	273.00	2.91	1.09
WAVE	14/11/2022 13:24	0.03	9.10	2	10.74	0.015	243.00	2.94	1.12
WAVE	14/11/2022 13:34	0.13	2.40	222	10.748	0.015	352.00	2.95	1.13
WAVE	14/11/2022 13:44	0.13	3.00	100	10.756	0.014	130.00	2.96	1.14
WAVE	14/11/2022 13:54	0.05	9.10	182	10.764	0.036	65.00	2.96	1.14
WAVE	14/11/2022 14:04	0.15	2.80	88	10.713	0.061	87.00	2.91	1.09
WAVE	14/11/2022 14:14	0.05	21.30	278	10.743	0.114	79.00	2.94	1.12
WAVE	14/11/2022 14:24	0.08	4.00	106	10.723	0.137	75.00	2.92	1.10
WAVE	14/11/2022 14:34	0.38	12.80	318	10.652	0.143	68.00	2.85	1.03
WAVE	14/11/2022 14:44	0.08	3.40	70	10.67	0.17	75.00	2.87	1.05
WAVE	14/11/2022 14:54	0.14	2.80	102	10.634	0.208	71.00	2.83	1.01
WAVE	14/11/2022 15:04	0.25	2.60	272	10.596	0.241	67.00	2.80	0.98
WAVE	14/11/2022 15:14	0.11	3.00	220	10.544	0.283	64.00	2.74	0.92
WAVE	14/11/2022 15:24	0.07	3.20	94	10.502	0.285	56.00	2.70	0.88
WAVE	14/11/2022 15:34	0.09	3.20	94	10.452	0.297	60.00	2.65	0.83
WAVE	14/11/2022 15:44	0.21	4.00	92	10.388	0.273	58.00	2.59	0.77
WAVE	14/11/2022 15:54	0.08	2.90	58	10.322	0.264	60.00	2.52	0.70
WAVE	14/11/2022 16:04	0.28	21.30	28	10.229	0.27	67.00	2.43	0.61
WAVE	14/11/2022 16:14	0.04	21.30	218	10.16	0.38	67.00	2.36	0.54
WAVE	14/11/2022 16:24	0.19	2.80	297	10.09	0.418	64.00	2.29	0.47
WAVE	14/11/2022 16:34	0.14	3.00	74	9.986	0.439	62.00	2.19	0.37
WAVE	14/11/2022 16:54	0.10	3.20	102	9.83	0.459	60.00	2.03	0.21
WAVE	14/11/2022 17:04	0.09	3.40	262	9.743	0.491	60.00	1.94	0.12
WAVE	14/11/2022 17:14	0.15	3.00	74	9.654	0.512	59.00	1.85	0.03
WAVE	14/11/2022 17:24	0.12	2.90	222	9.571	0.6	53.00	1.77	-0.05
WAVE	14/11/2022 17:34	0.05	10.70	278	9.483	0.615	54.00	1.68	-0.14
WAVE	14/11/2022 17:44	0.04	3.80	126	9.388	0.533	53.00	1.59	-0.23
WAVE	14/11/2022 17:54	0.44	9.10	26	9.36	0.517	53.00	1.56	-0.26
WAVE	14/11/2022 18:04	0.03	12.80	30	9.219	0.487	55.00	1.42	-0.40
WAVE	14/11/2022 18:14	0.02	9.10	118	9.148	0.466	59.00	1.35	-0.47
WAVE	14/11/2022 18:24	0.15	4.30	80	9.062	0.503	54.00	1.26	-0.56
WAVE	14/11/2022 18:34	0.07	4.00	102	9	0.434	69.00	1.20	-0.62
WAVE	14/11/2022 18:44	0.02	10.70	270	8.926	0.35	68.00	1.13	-0.69
WAVE	14/11/2022 18:54	0.03	9.10	10	8.861	0.324	62.00	1.06	-0.76
WAVE	14/11/2022 19:04	0.16	3.40	84	8.819	0.31	57.00	1.02	-0.80
WAVE	14/11/2022 19:14	0.03	12.80	82	8.781	0.312	64.00	0.98	-0.84
WAVE	14/11/2022 19:24	0.03	9.10	294	8.749	0.302	65.00	0.95	-0.87
WAVE	14/11/2022 19:44	0.06	5.80	318	8.694	0.246	76.00	0.89	-0.93
WAVE	14/11/2022 19:54	0.03	9.10	28	8.677	0.201	75.00	0.88	-0.94
WAVE	14/11/2022 20:04	0.07	3.20	202	8.667	0.148	80.00	0.87	-0.95
WAVE	14/11/2022 20:14	0.08	21.30	306	8.661	0.14	79.00	0.86	-0.96
WAVE	14/11/2022 20:24	0.10	2.50	130	8.654	0.099	83.00	0.85	-0.97
WAVE	14/11/2022 20:34	0.23	2.00	258	8.663	0.057	86.00	0.86	-0.96
WAVE	14/11/2022 20:44	0.07	2.70	134	8.679	0.027	126.00	0.88	-0.94
WAVE	14/11/2022 20:54	0.09	2.30	214	8.693	0.016	174.00	0.89	-0.93
WAVE	14/11/2022 21:04	0.03	12.80	14	8.714	0.066	196.00	0.91	-0.91
WAVE	14/11/2022 21:14	0.07	3.00	114	8.726	0.185	230.00	0.93	-0.89
WAVE	14/11/2022 21:24	0.03	9.10	262	8.755	0.195	235.00	0.96	-0.86
WAVE	14/11/2022 21:34	0.03	21.30	210	8.785	0.179	248.00	0.99	-0.84
WAVE	14/11/2022 21:44	0.68	9.10	166	8.883	0.182	240.00	1.08	-0.74
WAVE	14/11/2022 21:54	0.05	5.80	250	8.851	0.188	245.00	1.05	-0.77
WAVE	14/11/2022 22:04	0.04	9.10	28	8.862	0.225	249.00	1.06	-0.76
WAVE	14/11/2022 22:14	0.06	4.60	22	8.912	0.186	250.00	1.11	-0.71

Name	Date Time	Significant Height(m)	Peak Time(sec)	Peak Direction (degree)	ADCP Depth(m)	Current Speed(m/s)	Current Direction (degree)	water level reference to CD	water level reference to 1.82 SHD
WAVE	14/11/2022 22:24	0.03	9.10	270	8.967	0.201	253.00	1.17	-0.65
WAVE	14/11/2022 22:34	0.07	3.40	114	9.007	0.208	245.00	1.21	-0.61
WAVE	14/11/2022 22:44	0.06	8.00	306	9.062	0.257	255.00	1.26	-0.56
WAVE	14/11/2022 22:54	0.03	12.80	342	9.113	0.235	262.00	1.31	-0.51
WAVE	14/11/2022 23:04	0.02	10.70	318	9.175	0.238	257.00	1.38	-0.44
WAVE	14/11/2022 23:14	0.03	9.10	14	9.238	0.243	259.00	1.44	-0.38
WAVE	14/11/2022 23:24	0.21	3.60	127	9.29	0.29	268.00	1.49	-0.33
WAVE	14/11/2022 23:34	0.05	9.10	6	9.356	0.266	271.00	1.56	-0.26
WAVE	14/11/2022 23:44	0.04	9.10	314	9.415	0.301	260.00	1.62	-0.21
WAVE	14/11/2022 23:54	0.03	10.70	162	9.483	0.298	259.00	1.68	-0.14
WAVE	15/11/2022 00:04	0.06	2.70	130	9.54	0.283	261.00	1.74	-0.08
WAVE	15/11/2022 00:14	0.04	16.00	274	9.603	0.297	264.00	1.80	-0.02
WAVE	15/11/2022 00:24	0.04	16.00	322	9.66	0.275	265.00	1.86	0.04
WAVE	15/11/2022 00:34	0.03	9.10	262	9.711	0.26	268.00	1.91	0.09
WAVE	15/11/2022 00:44	0.04	7.10	82	9.775	0.273	270.00	1.98	0.16
WAVE	15/11/2022 00:54	0.03	21.30	198	9.83	0.257	265.00	2.03	0.21
WAVE	15/11/2022 01:04	0.09	2.80	28	9.893	0.244	260.00	2.09	0.27
WAVE	15/11/2022 01:14	0.06	9.10	30	9.947	0.234	257.00	2.15	0.33
WAVE	15/11/2022 01:24	0.05	8.00	226	10.008	0.212	262.00	2.21	0.39
WAVE	15/11/2022 01:34	0.13	2.50	122	10.064	0.156	266.00	2.26	0.44
WAVE	15/11/2022 01:54	0.04	9.10	150	10.172	0.175	252.00	2.37	0.55
WAVE	15/11/2022 02:04	0.03	16.00	14	10.231	0.171	244.00	2.43	0.61
WAVE	15/11/2022 02:14	0.06	5.30	30	10.282	0.201	252.00	2.48	0.66
WAVE	15/11/2022 02:24	0.03	9.10	118	10.333	0.216	253.00	2.53	0.71
WAVE	15/11/2022 02:34	0.05	12.80	2	10.389	0.181	252.00	2.59	0.77
WAVE	15/11/2022 02:44	0.06	6.40	218	10.447	0.18	255.00	2.65	0.83
WAVE	15/11/2022 02:54	0.09	2.30	262	10.492	0.171	249.00	2.69	0.87
WAVE	15/11/2022 03:04	0.15	2.40	116	10.519	0.158	250.00	2.72	0.90
WAVE	15/11/2022 03:14	0.06	10.70	230	10.551	0.083	264.00	2.75	0.93
WAVE	15/11/2022 03:24	0.04	12.80	226	10.57	0.094	267.00	2.77	0.95
WAVE	15/11/2022 03:34	0.05	10.70	286	10.589	0.081	271.00	2.79	0.97
WAVE	15/11/2022 03:44	0.03	9.10	158	10.588	0.052	261.00	2.79	0.97
WAVE	15/11/2022 03:54	0.03	21.30	274	10.585	0.017	291.00	2.79	0.97
WAVE	15/11/2022 04:04	0.03	12.80	330	10.593	0.021	326.00	2.79	0.97
WAVE	15/11/2022 04:14	0.05	4.00	346	10.589	0.061	22.00	2.79	0.97
WAVE	15/11/2022 04:24	0.06	12.80	278	10.585	0.067	46.00	2.79	0.97
WAVE	15/11/2022 04:34	0.07	5.30	130	10.569	0.101	50.00	2.77	0.95
WAVE	15/11/2022 04:54	0.04	5.30	102	10.525	0.187	42.00	2.73	0.91
WAVE	15/11/2022 05:04	0.07	3.00	150	10.501	0.226	44.00	2.70	0.88
WAVE	15/11/2022 05:14	0.04	10.70	106	10.462	0.27	40.00	2.66	0.84
WAVE	15/11/2022 05:24	0.05	9.10	122	10.423	0.298	48.00	2.62	0.80
WAVE	15/11/2022 05:34	0.05	10.70	74	10.391	0.292	59.00	2.59	0.77
WAVE	15/11/2022 05:44	0.03	16.00	318	10.355	0.304	61.00	2.56	0.74
WAVE	15/11/2022 05:54	0.05	6.40	50	10.31	0.294	65.00	2.51	0.69
WAVE	15/11/2022 06:04	0.09	2.90	28	10.267	0.27	72.00	2.47	0.65
WAVE	15/11/2022 06:14	0.03	12.80	314	10.237	0.27	81.00	2.44	0.62
WAVE	15/11/2022 06:24	0.07	3.00	28	10.19	0.278	85.00	2.39	0.57
WAVE	15/11/2022 06:34	0.03	16.00	42	10.138	0.254	95.00	2.34	0.52
WAVE	15/11/2022 06:44	0.06	16.00	302	10.095	0.259	98.00	2.30	0.48
WAVE	15/11/2022 06:54	0.39	9.10	338	10.032	0.253	98.00	2.23	0.41
WAVE	15/11/2022 07:04	0.14	4.00	78	10.011	0.22	98.00	2.21	0.39
WAVE	15/11/2022 07:14	0.12	3.60	74	9.971	0.222	99.00	2.17	0.35
WAVE	15/11/2022 07:24	0.33	2.90	292	9.933	0.241	91.00	2.13	0.31
WAVE	15/11/2022 07:34	0.10	2.70	250	9.899	0.277	93.00	2.10	0.28
WAVE	15/11/2022 07:44	0.04	10.70	266	9.868	0.285	88.00	2.07	0.25
WAVE	15/11/2022 07:54	0.06	5.80	210	9.849	0.284	85.00	2.05	0.23
WAVE	15/11/2022 08:04	0.09	3.00	94	9.825	0.264	95.00	2.03	0.20
WAVE	15/11/2022 08:14	0.11	3.00	110	9.812	0.218	99.00	2.01	0.19
WAVE	15/11/2022 08:24	0.09	2.70	322	9.798	0.152	107.00	2.00	0.18
WAVE	15/11/2022 08:34	0.07	3.00	142	9.797	0.169	109.00	2.00	0.18
WAVE	15/11/2022 08:44	0.06	4.30	30	9.787	0.106	133.00	1.99	0.17
WAVE	15/11/2022 08:54	0.04	16.00	270	9.788	0.108	126.00	1.99	0.17
WAVE	15/11/2022 09:04	0.03	12.80	28	9.797	0.062	170.00	2.00	0.18
WAVE	15/11/2022 09:14	0.21	2.80	136	9.804	0.031	204.00	2.00	0.18

Name	Date Time	Significant Height(m)	Peak Time(sec)	Peak Direction (degree)	ADCP Depth(m)	Current Speed(m/s)	Current Direction (degree)	water level reference to CD	water level reference to 1.82 SHD
WAVE	15/11/2022 09:24	0.07	4.00	110	9.814	0.098	207.00	2.01	0.19
WAVE	15/11/2022 09:34	0.41	2.90	99	9.835	0.098	249.00	2.04	0.22
WAVE	15/11/2022 09:44	0.10	3.00	94	9.856	0.119	242.00	2.06	0.24
WAVE	15/11/2022 09:54	0.07	2.90	302	9.884	0.16	252.00	2.08	0.26
WAVE	15/11/2022 10:04	0.15	2.70	97	9.906	0.149	250.00	2.11	0.29
WAVE	15/11/2022 10:14	0.05	3.40	104	9.929	0.133	264.00	2.13	0.31
WAVE	15/11/2022 10:24	0.03	9.10	258	9.95	0.146	281.00	2.15	0.33
WAVE	15/11/2022 10:34	0.06	7.10	230	9.983	0.157	269.00	2.18	0.36
WAVE	15/11/2022 10:44	0.07	3.00	110	10.01	0.158	267.00	2.21	0.39
WAVE	15/11/2022 10:54	0.02	10.70	298	10.032	0.149	287.00	2.23	0.41
WAVE	15/11/2022 11:04	0.14	3.80	102	10.065	0.123	265.00	2.27	0.45
WAVE	15/11/2022 11:14	0.09	2.90	106	10.091	0.12	278.00	2.29	0.47
WAVE	15/11/2022 11:34	0.13	12.80	190	10.185	0.098	259.00	2.39	0.57
WAVE	15/11/2022 11:44	0.02	10.70	130	10.174	0.098	269.00	2.37	0.55
WAVE	15/11/2022 11:54	0.58	10.70	126	10.226	0.069	263.00	2.43	0.61
WAVE	15/11/2022 12:04	0.06	3.20	112	10.249	0.07	265.00	2.45	0.63
WAVE	15/11/2022 12:14	0.03	21.30	274	10.286	0.087	242.00	2.49	0.67
WAVE	15/11/2022 12:24	0.07	4.00	126	10.315	0.106	240.00	2.52	0.70
WAVE	15/11/2022 12:34	0.10	3.20	94	10.356	0.133	256.00	2.56	0.74
WAVE	15/11/2022 12:44	0.08	3.00	310	10.386	0.131	250.00	2.59	0.77
WAVE	15/11/2022 12:54	0.03	10.70	28	10.429	0.144	245.00	2.63	0.81
WAVE	15/11/2022 13:04	0.05	5.80	28	10.457	0.125	228.00	2.66	0.84
WAVE	15/11/2022 13:14	0.04	9.10	126	10.486	0.115	232.00	2.69	0.87
WAVE	15/11/2022 13:24	0.12	3.40	106	10.514	0.132	236.00	2.71	0.89
WAVE	15/11/2022 13:34	0.02	12.80	302	10.545	0.12	240.00	2.75	0.93
WAVE	15/11/2022 13:44	0.04	9.10	262	10.569	0.111	242.00	2.77	0.95
WAVE	15/11/2022 13:54	0.03	16.00	98	10.59	0.089	244.00	2.79	0.97
WAVE	15/11/2022 14:04	0.17	2.70	300	10.596	0.055	265.00	2.80	0.98
WAVE	15/11/2022 14:14	0.18	3.00	284	10.597	0.028	228.00	2.80	0.98
WAVE	15/11/2022 14:24	0.07	3.80	334	10.607	0.005	301.00	2.81	0.99
WAVE	15/11/2022 14:34	0.10	2.80	94	10.616	0.013	5.00	2.82	1.00
WAVE	15/11/2022 14:44	0.25	3.20	297	10.612	0.048	33.00	2.81	0.99
WAVE	15/11/2022 14:54	0.12	2.90	326	10.595	0.074	58.00	2.80	0.98
WAVE	15/11/2022 15:04	0.09	3.20	122	10.584	0.123	46.00	2.78	0.96
WAVE	15/11/2022 15:14	0.10	2.60	218	10.549	0.172	50.00	2.75	0.93
WAVE	15/11/2022 15:24	0.05	3.40	30	10.526	0.192	59.00	2.73	0.91
WAVE	15/11/2022 15:34	0.45	10.70	250	10.445	0.178	57.00	2.65	0.83
WAVE	15/11/2022 15:44	0.13	2.60	218	10.447	0.245	57.00	2.65	0.83
WAVE	15/11/2022 15:54	0.11	3.20	30	10.395	0.271	58.00	2.60	0.78
WAVE	15/11/2022 16:04	0.06	9.10	322	10.353	0.289	63.00	2.55	0.73
WAVE	15/11/2022 16:14	0.06	3.60	310	10.298	0.288	72.00	2.50	0.68
WAVE	15/11/2022 16:24	0.07	5.80	234	10.239	0.28	77.00	2.44	0.62
WAVE	15/11/2022 16:34	0.30	2.90	314	10.18	0.29	78.00	2.38	0.56
WAVE	15/11/2022 16:44	0.08	3.00	106	10.104	0.316	80.00	2.30	0.48
WAVE	15/11/2022 16:54	0.13	4.30	64	10.053	0.315	79.00	2.25	0.43
WAVE	15/11/2022 17:04	0.05	21.30	226	9.984	0.335	76.00	2.18	0.36
WAVE	15/11/2022 17:14	0.08	4.00	66	9.911	0.398	73.00	2.11	0.29
WAVE	15/11/2022 17:24	0.28	3.20	251	9.842	0.377	77.00	2.04	0.22
WAVE	15/11/2022 17:34	0.05	5.80	326	9.775	0.424	73.00	1.98	0.16
WAVE	15/11/2022 17:44	0.05	4.90	314	9.7	0.427	65.00	1.90	0.08
WAVE	15/11/2022 17:54	0.07	3.40	62	9.636	0.432	63.00	1.84	0.02
WAVE	15/11/2022 18:04	0.07	3.60	134	9.565	0.427	64.00	1.77	-0.06
WAVE	15/11/2022 18:14	0.07	3.40	38	9.49	0.444	64.00	1.69	-0.13
WAVE	15/11/2022 18:34	0.06	3.40	122	9.343	0.463	57.00	1.54	-0.28
WAVE	15/11/2022 18:44	0.11	3.80	118	9.274	0.423	66.00	1.47	-0.35
WAVE	15/11/2022 18:54	0.12	3.40	106	9.205	0.322	77.00	1.41	-0.42
WAVE	15/11/2022 19:04	0.13	3.00	118	9.139	0.357	65.00	1.34	-0.48
WAVE	15/11/2022 19:14	0.08	3.60	126	9.081	0.352	73.00	1.28	-0.54
WAVE	15/11/2022 19:24	0.03	9.10	310	9.032	0.253	60.00	1.23	-0.59
WAVE	15/11/2022 19:34	0.08	2.80	74	8.981	0.216	75.00	1.18	-0.64
WAVE	15/11/2022 19:44	0.12	2.70	250	8.954	0.203	79.00	1.15	-0.67
WAVE	15/11/2022 19:54	0.09	2.70	114	8.908	0.147	86.00	1.11	-0.71
WAVE	15/11/2022 20:04	0.09	3.00	138	8.883	0.163	72.00	1.08	-0.74
WAVE	15/11/2022 20:14	0.09	10.70	350	8.856	0.162	78.00	1.06	-0.76

Name	Date Time	Significant Height(m)	Peak Time(sec)	Peak Direction (degree)	ADCP Depth(m)	Current Speed(m/s)	Current Direction (degree)	water level reference to CD	water level reference to 1.82 SHD
WAVE	15/11/2022 20:24	0.08	3.00	118	8.847	0.133	74.00	1.05	-0.77
WAVE	15/11/2022 20:34	0.10	2.80	74	8.837	0.108	89.00	1.04	-0.78
WAVE	15/11/2022 20:44	0.21	2.10	302	8.827	0.072	79.00	1.03	-0.79
WAVE	15/11/2022 20:54	0.10	2.90	110	8.834	0.061	97.00	1.03	-0.79
WAVE	15/11/2022 21:04	0.12	2.50	98	8.839	0.023	122.00	1.04	-0.78
WAVE	15/11/2022 21:14	0.10	3.20	338	8.839	0.012	60.00	1.04	-0.78
WAVE	15/11/2022 21:24	0.03	12.80	294	8.844	0.02	244.00	1.04	-0.78
WAVE	15/11/2022 21:34	0.21	3.20	122	8.843	0.079	229.00	1.04	-0.78
WAVE	15/11/2022 21:44	0.02	10.70	290	8.855	0.136	238.00	1.06	-0.76
WAVE	15/11/2022 22:04	0.02	10.70	306	8.897	0.108	237.00	1.10	-0.72
WAVE	15/11/2022 22:14	0.16	3.40	238	8.912	0.106	250.00	1.11	-0.71
WAVE	15/11/2022 22:34	0.23	3.00	107	8.953	0.123	255.00	1.15	-0.67
WAVE	15/11/2022 22:54	0.03	21.30	74	8.994	0.167	254.00	1.19	-0.63
WAVE	15/11/2022 23:04	0.07	5.80	2	9.02	0.173	259.00	1.22	-0.60
WAVE	15/11/2022 23:14	0.08	8.00	246	9.05	0.163	262.00	1.25	-0.57
WAVE	15/11/2022 23:24	0.10	10.70	230	9.088	0.158	266.00	1.29	-0.53
WAVE	15/11/2022 23:34	0.20	3.00	114	9.127	0.15	269.00	1.33	-0.49
WAVE	16/11/2022 00:04	0.04	10.70	46	9.249	0.217	262.00	1.45	-0.37
WAVE	16/11/2022 00:14	0.04	16.00	134	9.303	0.248	263.00	1.50	-0.32
WAVE	16/11/2022 00:24	0.10	2.60	28	9.349	0.241	254.00	1.55	-0.27
WAVE	16/11/2022 00:34	0.03	16.00	28	9.405	0.259	253.00	1.61	-0.22
WAVE	16/11/2022 00:44	0.06	9.10	154	9.456	0.265	249.00	1.66	-0.16
WAVE	16/11/2022 00:54	0.57	16.00	154	9.539	0.231	252.00	1.74	-0.08
WAVE	16/11/2022 01:04	0.05	3.40	294	9.562	0.252	254.00	1.76	-0.06
WAVE	16/11/2022 01:14	0.08	3.20	28	9.61	0.268	258.00	1.81	-0.01
WAVE	16/11/2022 01:24	0.11	2.30	28	9.658	0.296	262.00	1.86	0.04
WAVE	16/11/2022 01:34	0.07	3.00	338	9.714	0.286	270.00	1.91	0.09
WAVE	16/11/2022 01:44	0.10	2.70	234	9.758	0.274	266.00	1.96	0.14
WAVE	16/11/2022 01:54	0.03	16.00	174	9.817	0.292	263.00	2.02	0.20
WAVE	16/11/2022 02:04	0.08	10.70	54	9.86	0.297	267.00	2.06	0.24
WAVE	16/11/2022 02:14	0.03	16.00	90	9.902	0.16	259.00	2.10	0.28
WAVE	16/11/2022 02:24	0.07	5.30	306	9.938	0.136	273.00	2.14	0.32
WAVE	16/11/2022 02:34	0.03	9.10	18	9.985	0.139	264.00	2.19	0.37
WAVE	16/11/2022 02:44	0.03	12.80	258	10.019	0.114	260.00	2.22	0.40
WAVE	16/11/2022 02:54	0.04	10.70	166	10.054	0.067	264.00	2.25	0.43
WAVE	16/11/2022 03:04	0.03	10.70	338	10.104	0.108	268.00	2.30	0.48
WAVE	16/11/2022 03:14	0.06	4.00	290	10.152	0.12	249.00	2.35	0.53
WAVE	16/11/2022 03:24	0.23	2.60	130	10.177	0.115	265.00	2.38	0.56
WAVE	16/11/2022 03:34	0.05	10.70	70	10.221	0.123	262.00	2.42	0.60
WAVE	16/11/2022 03:44	0.03	9.10	194	10.253	0.113	272.00	2.45	0.63
WAVE	16/11/2022 03:54	0.08	3.60	146	10.276	0.132	272.00	2.48	0.66
WAVE	16/11/2022 04:04	0.06	3.60	70	10.316	0.095	273.00	2.52	0.70
WAVE	16/11/2022 04:14	0.03	6.40	198	10.337	0.106	290.00	2.54	0.72
WAVE	16/11/2022 04:24	0.03	16.00	190	10.362	0.153	303.00	2.56	0.74
WAVE	16/11/2022 04:34	0.04	12.80	238	10.381	0.046	288.00	2.58	0.76
WAVE	16/11/2022 04:44	0.06	5.80	154	10.394	0.019	336.00	2.59	0.77
WAVE	16/11/2022 04:54	0.04	9.10	28	10.401	0.028	359.00	2.60	0.78
WAVE	16/11/2022 05:04	0.04	12.80	306	10.412	0.056	320.00	2.61	0.79
WAVE	16/11/2022 05:14	0.03	16.00	262	10.411	0.052	27.00	2.61	0.79
WAVE	16/11/2022 05:24	0.03	10.70	250	10.409	0.103	57.00	2.61	0.79
WAVE	16/11/2022 05:34	0.03	9.10	222	10.407	0.112	61.00	2.61	0.79
WAVE	16/11/2022 05:54	0.07	3.40	122	10.384	0.144	62.00	2.58	0.76
WAVE	16/11/2022 06:04	0.05	21.30	290	10.402	0.176	55.00	2.60	0.78
WAVE	16/11/2022 06:14	0.10	2.70	302	10.372	0.163	56.00	2.57	0.75
WAVE	16/11/2022 06:24	0.05	5.30	46	10.369	0.191	64.00	2.57	0.75
WAVE	16/11/2022 06:34	0.07	5.80	28	10.339	0.213	71.00	2.54	0.72
WAVE	16/11/2022 06:44	0.03	10.70	150	10.322	0.146	75.00	2.52	0.70
WAVE	16/11/2022 06:54	0.03	10.70	238	10.294	0.162	73.00	2.49	0.67
WAVE	16/11/2022 07:04	0.08	3.60	122	10.261	0.169	86.00	2.46	0.64
WAVE	16/11/2022 07:14	0.12	4.00	98	10.236	0.162	75.00	2.44	0.62
WAVE	16/11/2022 07:24	0.06	9.10	28	10.21	0.185	86.00	2.41	0.59
WAVE	16/11/2022 07:34	0.11	2.80	138	10.181	0.185	90.00	2.38	0.56
WAVE	16/11/2022 07:44	0.04	10.70	342	10.139	0.248	83.00	2.34	0.52
WAVE	16/11/2022 07:54	0.07	3.20	70	10.104	0.228	86.00	2.30	0.48

Name	Date Time	Significant Height(m)	Peak Time(sec)	Peak Direction (degree)	ADCP Depth(m)	Current Speed(m/s)	Current Direction (degree)	water level reference to CD	water level reference to 1.82 SHD
WAVE	16/11/2022 08:04	0.21	2.20	202	10.074	0.256	77.00	2.27	0.45
WAVE	16/11/2022 08:14	0.09	3.80	298	10.037	0.229	81.00	2.24	0.42
WAVE	16/11/2022 08:24	0.11	3.40	120	10.01	0.248	83.00	2.21	0.39
WAVE	16/11/2022 08:34	0.23	9.10	166	9.974	0.262	84.00	2.17	0.35
WAVE	16/11/2022 08:44	0.21	2.80	30	9.963	0.262	84.00	2.16	0.34
WAVE	16/11/2022 08:54	0.11	2.80	290	9.941	0.249	84.00	2.14	0.32
WAVE	16/11/2022 09:04	0.07	9.10	338	9.919	0.232	79.00	2.12	0.30
WAVE	16/11/2022 09:14	0.17	3.40	118	9.901	0.214	87.00	2.10	0.28
WAVE	16/11/2022 09:24	0.08	3.20	138	9.884	0.187	82.00	2.08	0.26
WAVE	16/11/2022 09:34	0.12	2.90	94	9.874	0.139	90.00	2.07	0.25
WAVE	16/11/2022 09:44	0.15	3.20	98	9.858	0.108	94.00	2.06	0.24
WAVE	16/11/2022 09:54	0.04	12.80	154	9.856	0.101	99.00	2.06	0.24
WAVE	16/11/2022 10:04	0.10	2.90	150	9.856	0.068	114.00	2.06	0.24
WAVE	16/11/2022 10:14	0.40	9.10	306	9.886	0.05	118.00	2.09	0.27
WAVE	16/11/2022 10:24	0.07	21.30	302	9.874	0.018	151.00	2.07	0.25
WAVE	16/11/2022 10:34	0.05	8.00	26	9.882	0.027	226.00	2.08	0.26
WAVE	16/11/2022 10:44	0.16	3.60	238	9.898	0.06	253.00	2.10	0.28
WAVE	16/11/2022 10:54	0.08	3.80	28	9.913	0.093	263.00	2.11	0.29
WAVE	16/11/2022 11:04	0.17	2.90	110	9.929	0.087	270.00	2.13	0.31
WAVE	16/11/2022 11:14	0.04	10.70	26	9.948	0.092	269.00	2.15	0.33
WAVE	16/11/2022 11:24	0.03	16.00	28	9.971	0.084	272.00	2.17	0.35
WAVE	16/11/2022 11:34	0.04	21.30	86	10.005	0.095	251.00	2.21	0.39
WAVE	16/11/2022 11:44	0.11	2.70	106	10.029	0.091	256.00	2.23	0.41
WAVE	16/11/2022 11:54	0.15	2.70	122	10.059	0.089	271.00	2.26	0.44
WAVE	16/11/2022 12:04	0.06	3.40	242	10.09	0.1	285.00	2.29	0.47
WAVE	16/11/2022 12:14	0.09	4.00	230	10.111	0.119	301.00	2.31	0.49
WAVE	16/11/2022 12:24	0.16	3.00	114	10.139	0.092	282.00	2.34	0.52
WAVE	16/11/2022 12:34	0.03	9.10	28	10.159	0.083	285.00	2.36	0.54
WAVE	16/11/2022 12:44	0.03	21.30	150	10.195	0.071	279.00	2.40	0.58
WAVE	16/11/2022 12:54	0.08	3.00	246	10.226	0.083	285.00	2.43	0.61
WAVE	16/11/2022 13:04	0.02	10.70	274	10.249	0.046	277.00	2.45	0.63
WAVE	16/11/2022 13:14	0.06	4.30	210	10.281	0.022	266.00	2.48	0.66
WAVE	16/11/2022 13:24	0.24	2.90	289	10.306	0.037	240.00	2.51	0.69
WAVE	16/11/2022 13:34	0.05	12.80	214	10.312	0.016	92.00	2.51	0.69
WAVE	16/11/2022 13:44	0.03	10.70	28	10.348	0.019	278.00	2.55	0.73
WAVE	16/11/2022 13:54	0.09	2.90	117	10.352	0.061	300.00	2.55	0.73
WAVE	16/11/2022 14:04	0.11	3.20	242	10.37	0.011	181.00	2.57	0.75
WAVE	16/11/2022 14:14	0.17	3.00	109	10.392	0.025	83.00	2.59	0.77
WAVE	16/11/2022 14:24	0.12	2.40	222	10.404	0.037	94.00	2.60	0.78
WAVE	16/11/2022 14:34	0.04	10.70	94	10.4	0.08	74.00	2.60	0.78
WAVE	16/11/2022 14:44	0.11	3.00	134	10.412	0.057	48.00	2.61	0.79
WAVE	16/11/2022 14:54	0.04	9.10	110	10.415	0.088	44.00	2.62	0.79
WAVE	16/11/2022 15:04	0.08	3.80	106	10.412	0.123	54.00	2.61	0.79
WAVE	16/11/2022 15:14	0.22	2.60	109	10.412	0.118	81.00	2.61	0.79
WAVE	16/11/2022 15:24	0.03	9.10	14	10.403	0.15	67.00	2.60	0.78
WAVE	16/11/2022 15:34	0.21	16.00	142	10.376	0.128	77.00	2.58	0.76
WAVE	16/11/2022 15:44	0.22	2.90	209	10.392	0.178	64.00	2.59	0.77
WAVE	16/11/2022 15:54	0.09	3.80	106	10.372	0.167	69.00	2.57	0.75
WAVE	16/11/2022 16:04	0.09	2.80	112	10.356	0.225	70.00	2.56	0.74
WAVE	16/11/2022 16:14	0.06	16.00	114	10.333	0.216	74.00	2.53	0.71
WAVE	16/11/2022 16:24	0.04	21.30	148	10.31	0.201	74.00	2.51	0.69
WAVE	16/11/2022 16:34	0.06	16.00	122	10.268	0.19	69.00	2.47	0.65
WAVE	16/11/2022 16:44	0.04	9.10	346	10.267	0.225	60.00	2.47	0.65
WAVE	16/11/2022 16:54	0.06	9.10	202	10.229	0.24	77.00	2.43	0.61
WAVE	16/11/2022 17:04	0.04	9.10	210	10.193	0.251	73.00	2.39	0.57
WAVE	16/11/2022 17:14	0.05	9.10	186	10.151	0.246	77.00	2.35	0.53
WAVE	16/11/2022 17:24	0.36	9.10	258	10.083	0.245	80.00	2.28	0.46
WAVE	16/11/2022 17:34	0.05	12.80	306	10.065	0.257	65.00	2.27	0.45
WAVE	16/11/2022 17:44	0.15	2.80	296	10.024	0.268	84.00	2.22	0.40
WAVE	16/11/2022 17:54	0.03	12.80	28	9.984	0.26	77.00	2.18	0.36
WAVE	16/11/2022 18:04	0.09	3.80	94	9.914	0.283	68.00	2.11	0.29
WAVE	16/11/2022 18:14	0.09	2.60	330	9.867	0.274	80.00	2.07	0.25
WAVE	16/11/2022 18:24	0.17	3.00	104	9.814	0.264	66.00	2.01	0.19
WAVE	16/11/2022 18:34	0.05	9.10	266	9.757	0.266	74.00	1.96	0.14

Name	Date Time	Significant Height(m)	Peak Time(sec)	Peak Direction (degree)	ADCP Depth(m)	Current Speed(m/s)	Current Direction (degree)	water level reference to CD	water level reference to 1.82 SHD
WAVE	16/11/2022 18:44	0.10	4.00	86	9.712	0.34	54.00	1.91	0.09
WAVE	16/11/2022 18:54	0.16	2.80	250	9.657	0.311	59.00	1.86	0.04
WAVE	16/11/2022 19:04	0.05	5.80	234	9.589	0.326	55.00	1.79	-0.03
WAVE	16/11/2022 19:14	0.09	3.20	214	9.531	0.331	56.00	1.73	-0.09
WAVE	16/11/2022 19:24	0.05	6.40	138	9.48	0.281	61.00	1.68	-0.14
WAVE	16/11/2022 19:34	0.11	3.60	90	9.418	0.312	57.00	1.62	-0.20
WAVE	16/11/2022 19:44	0.04	21.30	198	9.36	0.315	53.00	1.56	-0.26
WAVE	16/11/2022 19:54	0.07	4.90	114	9.309	0.305	52.00	1.51	-0.31
WAVE	16/11/2022 20:04	0.07	10.70	122	9.261	0.28	49.00	1.46	-0.36
WAVE	16/11/2022 20:14	0.05	7.10	206	9.223	0.293	53.00	1.42	-0.40
WAVE	16/11/2022 20:24	0.26	2.40	246	9.181	0.244	59.00	1.38	-0.44
WAVE	16/11/2022 20:34	0.17	2.20	226	9.129	0.243	55.00	1.33	-0.49
WAVE	16/11/2022 20:44	0.15	2.80	106	9.091	0.274	57.00	1.29	-0.53
WAVE	16/11/2022 20:54	0.23	2.40	230	9.059	0.203	52.00	1.26	-0.56
WAVE	16/11/2022 21:04	0.03	10.70	314	9.033	0.213	55.00	1.23	-0.59
WAVE	16/11/2022 21:14	0.03	9.10	174	9.016	0.132	58.00	1.22	-0.60
WAVE	16/11/2022 21:24	0.02	12.80	342	9	0.1	41.00	1.20	-0.62
WAVE	16/11/2022 21:34	0.06	5.80	126	8.993	0.1	52.00	1.19	-0.63
WAVE	16/11/2022 21:44	0.05	7.10	28	8.985	0.107	52.00	1.19	-0.64
WAVE	16/11/2022 21:54	0.40	10.70	306	9.054	0.05	44.00	1.25	-0.57
WAVE	16/11/2022 22:04	0.04	10.70	186	8.981	0.017	356.00	1.18	-0.64
WAVE	16/11/2022 22:14	0.04	21.30	282	8.989	0.025	205.00	1.19	-0.63
WAVE	16/11/2022 22:24	0.07	2.80	302	8.984	0.029	186.00	1.18	-0.64
WAVE	16/11/2022 22:34	0.08	3.80	110	8.991	0.061	199.00	1.19	-0.63
WAVE	16/11/2022 22:44	0.03	10.70	334	9.004	0.094	218.00	1.20	-0.62
WAVE	16/11/2022 23:04	0.05	16.00	338	9.036	0.075	219.00	1.24	-0.58
WAVE	16/11/2022 23:14	0.06	10.70	28	9.06	0.074	246.00	1.26	-0.56
WAVE	16/11/2022 23:24	0.05	9.10	28	9.078	0.072	237.00	1.28	-0.54
WAVE	16/11/2022 23:44	0.07	9.10	30	9.116	0.063	266.00	1.32	-0.50
WAVE	16/11/2022 23:54	0.09	2.90	270	9.137	0.045	268.00	1.34	-0.48
WAVE	17/11/2022 00:04	0.07	10.70	322	9.157	0.03	267.00	1.36	-0.46
WAVE	17/11/2022 00:14	0.19	2.20	130	9.173	0.029	301.00	1.37	-0.45
WAVE	17/11/2022 00:24	0.05	21.30	298	9.208	0.017	337.00	1.41	-0.41
WAVE	17/11/2022 00:34	0.68	10.70	28	9.318	0.005	85.00	1.52	-0.30
WAVE	17/11/2022 00:44	0.03	9.10	278	9.268	0.004	301.00	1.47	-0.35
WAVE	17/11/2022 00:54	0.25	2.10	350	9.296	0.025	299.00	1.50	-0.32
WAVE	17/11/2022 01:04	0.18	2.50	306	9.335	0.04	244.00	1.54	-0.28
WAVE	17/11/2022 01:14	0.05	12.80	218	9.356	0.058	254.00	1.56	-0.26
WAVE	17/11/2022 01:24	0.06	12.80	278	9.383	0.105	248.00	1.58	-0.24
WAVE	17/11/2022 01:34	0.06	2.90	290	9.427	0.097	260.00	1.63	-0.19
WAVE	17/11/2022 01:44	0.04	10.70	114	9.479	0.119	264.00	1.68	-0.14
WAVE	17/11/2022 01:54	0.02	16.00	314	9.516	0.114	261.00	1.72	-0.10
WAVE	17/11/2022 02:04	0.26	2.00	162	9.557	0.113	278.00	1.76	-0.06
WAVE	17/11/2022 02:14	0.03	10.70	102	9.607	0.128	237.00	1.81	-0.01
WAVE	17/11/2022 02:24	0.03	10.70	250	9.645	0.149	249.00	1.85	0.02
WAVE	17/11/2022 02:34	0.03	21.30	170	9.697	0.151	251.00	1.90	0.08
WAVE	17/11/2022 02:44	0.39	12.80	326	9.766	0.159	246.00	1.97	0.15
WAVE	17/11/2022 02:54	0.11	2.80	28	9.793	0.164	249.00	1.99	0.17
WAVE	17/11/2022 03:04	0.06	4.00	142	9.835	0.155	253.00	2.04	0.22
WAVE	17/11/2022 03:14	0.04	9.10	178	9.881	0.143	263.00	2.08	0.26
WAVE	17/11/2022 03:24	0.05	7.10	282	9.931	0.145	246.00	2.13	0.31
WAVE	17/11/2022 03:34	0.02	9.10	234	9.968	0.118	253.00	2.17	0.35
WAVE	17/11/2022 03:44	0.03	7.10	98	10.021	0.116	269.00	2.22	0.40
WAVE	17/11/2022 03:54	0.03	10.70	118	10.067	0.119	270.00	2.27	0.45
WAVE	17/11/2022 04:04	0.05	8.00	294	10.101	0.126	261.00	2.30	0.48
WAVE	17/11/2022 04:14	0.08	21.30	234	10.14	0.089	260.00	2.34	0.52
WAVE	17/11/2022 04:24	0.26	9.10	126	10.141	0.092	262.00	2.34	0.52
WAVE	17/11/2022 04:34	0.03	9.10	302	10.216	0.073	253.00	2.42	0.60
WAVE	17/11/2022 04:44	0.04	9.10	306	10.253	0.051	250.00	2.45	0.63
WAVE	17/11/2022 04:54	0.06	4.30	158	10.283	0.053	246.00	2.48	0.66
WAVE	17/11/2022 05:04	0.04	10.70	130	10.312	0.043	271.00	2.51	0.69
WAVE	17/11/2022 05:14	0.03	10.70	286	10.362	0.034	283.00	2.56	0.74
WAVE	17/11/2022 05:24	0.10	4.30	142	10.37	0.01	248.00	2.57	0.75
WAVE	17/11/2022 05:34	0.06	3.80	202	10.387	0.019	287.00	2.59	0.77

Name	Date Time	Significant Height(m)	Peak Time(sec)	Peak Direction (degree)	ADCP Depth(m)	Current Speed(m/s)	Current Direction (degree)	water level reference to CD	water level reference to 1.82 SHD
WAVE	17/11/2022 05:44	0.02	9.10	28	10.401	0.018	118.00	2.60	0.78
WAVE	17/11/2022 05:54	0.04	9.10	218	10.413	0.019	46.00	2.61	0.79
WAVE	17/11/2022 06:04	0.04	3.80	222	10.418	0.063	66.00	2.62	0.80
WAVE	17/11/2022 06:14	0.09	2.50	306	10.413	0.062	55.00	2.61	0.79
WAVE	17/11/2022 06:24	0.04	9.10	294	10.423	0.083	53.00	2.62	0.80
WAVE	17/11/2022 06:34	0.07	4.30	330	10.425	0.118	68.00	2.63	0.81
WAVE	17/11/2022 06:44	0.08	2.40	182	10.426	0.114	59.00	2.63	0.81
WAVE	17/11/2022 06:54	0.07	4.00	126	10.417	0.117	62.00	2.62	0.80
WAVE	17/11/2022 07:04	0.58	9.10	306	10.321	0.137	76.00	2.52	0.70
WAVE	17/11/2022 07:14	0.05	3.40	114	10.392	0.171	66.00	2.59	0.77
WAVE	17/11/2022 07:24	0.35	3.20	267	10.381	0.181	81.00	2.58	0.76
WAVE	17/11/2022 07:34	0.12	2.30	220	10.347	0.2	77.00	2.55	0.73
WAVE	17/11/2022 07:44	0.05	9.10	50	10.324	0.166	77.00	2.52	0.70
WAVE	17/11/2022 08:04	0.10	2.90	78	10.268	0.181	85.00	2.47	0.65
WAVE	17/11/2022 08:24	0.04	12.80	286	10.205	0.211	85.00	2.41	0.59
WAVE	17/11/2022 08:34	0.09	2.80	98	10.193	0.183	82.00	2.39	0.57
WAVE	17/11/2022 08:44	0.03	9.10	298	10.163	0.188	85.00	2.36	0.54
WAVE	17/11/2022 08:54	0.04	16.00	18	10.121	0.237	80.00	2.32	0.50
WAVE	17/11/2022 09:04	0.08	2.80	298	10.097	0.227	83.00	2.30	0.48
WAVE	17/11/2022 09:14	0.09	3.80	112	10.056	0.235	91.00	2.26	0.44
WAVE	17/11/2022 09:24	0.14	3.00	90	10.02	0.222	78.00	2.22	0.40
WAVE	17/11/2022 09:34	0.09	3.80	106	9.996	0.219	76.00	2.20	0.38
WAVE	17/11/2022 09:44	0.10	2.70	130	9.968	0.253	80.00	2.17	0.35
WAVE	17/11/2022 09:54	0.05	6.40	210	9.944	0.22	80.00	2.14	0.32
WAVE	17/11/2022 10:04	0.10	3.60	108	9.925	0.229	88.00	2.13	0.31
WAVE	17/11/2022 10:14	0.11	2.80	28	9.888	0.202	89.00	2.09	0.27
WAVE	17/11/2022 10:24	0.11	2.80	242	9.871	0.177	82.00	2.07	0.25
WAVE	17/11/2022 10:34	0.12	2.80	54	9.853	0.133	85.00	2.05	0.23
WAVE	17/11/2022 10:44	0.03	16.00	330	9.842	0.107	84.00	2.04	0.22
WAVE	17/11/2022 10:54	0.14	2.80	98	9.829	0.113	63.00	2.03	0.21
WAVE	17/11/2022 11:04	0.03	21.30	162	9.827	0.103	86.00	2.03	0.21
WAVE	17/11/2022 11:14	0.04	10.70	150	9.824	0.07	92.00	2.02	0.20
WAVE	17/11/2022 11:24	0.03	12.80	118	9.819	0.061	95.00	2.02	0.20
WAVE	17/11/2022 11:34	0.08	3.40	105	9.749	0.049	71.00	1.95	0.13
WAVE	17/11/2022 11:44	0.16	3.80	76	9.817	0.014	126.00	2.02	0.20
WAVE	17/11/2022 11:54	0.03	10.70	234	9.841	0.024	70.00	2.04	0.22
WAVE	17/11/2022 12:04	0.13	2.20	2	9.844	0.013	113.00	2.04	0.22
WAVE	17/11/2022 12:14	0.13	3.20	86	9.86	0.005	167.00	2.06	0.24
WAVE	17/11/2022 12:24	0.03	10.70	146	9.873	0.028	11.00	2.07	0.25
WAVE	17/11/2022 12:34	0.03	16.00	270	9.892	0.061	306.00	2.09	0.27
WAVE	17/11/2022 12:44	0.23	3.20	119	9.907	0.018	298.00	2.11	0.29
WAVE	17/11/2022 12:54	0.20	3.40	111	9.923	0.042	279.00	2.12	0.30
WAVE	17/11/2022 13:04	0.02	12.80	146	9.947	0.041	299.00	2.15	0.33
WAVE	17/11/2022 13:14	0.20	2.10	346	10.005	0.018	269.00	2.21	0.39
WAVE	17/11/2022 13:24	0.09	2.70	300	9.987	0.039	261.00	2.19	0.37
WAVE	17/11/2022 13:34	0.04	10.70	162	10.018	0.055	291.00	2.22	0.40
WAVE	17/11/2022 13:44	0.03	21.30	182	9.994	0.074	264.00	2.19	0.37
WAVE	17/11/2022 13:54	0.16	3.40	138	10.072	0.072	283.00	2.27	0.45
WAVE	17/11/2022 14:04	0.13	2.90	102	10.087	0.104	344.00	2.29	0.47
WAVE	17/11/2022 14:14	0.07	2.90	302	10.126	0.068	288.00	2.33	0.51
WAVE	17/11/2022 14:24	0.12	3.20	110	10.142	0.052	291.00	2.34	0.52
WAVE	17/11/2022 14:34	0.03	10.70	190	10.161	0.035	271.00	2.36	0.54
WAVE	17/11/2022 14:44	0.03	12.80	322	10.183	0.018	279.00	2.38	0.56
WAVE	17/11/2022 14:54	0.26	2.40	130	10.192	0.02	228.00	2.39	0.57
WAVE	17/11/2022 15:04	0.10	2.30	126	10.217	0.025	67.00	2.42	0.60
WAVE	17/11/2022 15:14	0.03	10.70	26	10.212	0.034	67.00	2.41	0.59
WAVE	17/11/2022 15:24	0.03	12.80	28	10.208	0.059	28.00	2.41	0.59
WAVE	17/11/2022 15:34	0.11	3.40	246	10.219	0.053	77.00	2.42	0.60
WAVE	17/11/2022 15:44	0.04	21.30	150	10.212	0.087	70.00	2.41	0.59
WAVE	17/11/2022 15:54	0.06	3.60	94	10.211	0.11	74.00	2.41	0.59
WAVE	17/11/2022 16:04	0.02	12.80	74	10.208	0.116	75.00	2.41	0.59
WAVE	17/11/2022 16:14	0.05	12.80	102	10.196	0.143	80.00	2.40	0.58
WAVE	17/11/2022 16:24	0.08	21.30	290	10.19	0.159	75.00	2.39	0.57
WAVE	17/11/2022 16:34	0.07	6.40	28	10.176	0.174	80.00	2.38	0.56

Name	Date Time	Significant Height(m)	Peak Time(sec)	Peak Direction (degree)	ADCP Depth(m)	Current Speed(m/s)	Current Direction (degree)	water level reference to CD	water level reference to 1.82 SHD
WAVE	17/11/2022 16:44	0.09	2.90	106	10.158	0.172	79.00	2.36	0.54
WAVE	17/11/2022 16:54	0.03	12.80	238	10.135	0.163	77.00	2.34	0.52
WAVE	17/11/2022 17:04	0.20	2.90	214	10.119	0.168	71.00	2.32	0.50
WAVE	17/11/2022 17:14	0.03	12.80	28	10.096	0.166	72.00	2.30	0.48
WAVE	17/11/2022 17:24	0.08	10.70	286	10.076	0.152	82.00	2.28	0.46
WAVE	17/11/2022 17:34	0.10	3.60	98	10.052	0.146	78.00	2.25	0.43
WAVE	17/11/2022 17:44	0.14	16.00	238	10.006	0.133	75.00	2.21	0.39
WAVE	17/11/2022 17:54	0.09	2.80	28	10.025	0.16	76.00	2.23	0.41
WAVE	17/11/2022 18:04	0.04	21.30	162	10.002	0.172	72.00	2.20	0.38
WAVE	17/11/2022 18:14	0.08	3.20	114	9.979	0.156	71.00	2.18	0.36
WAVE	17/11/2022 18:24	0.09	3.80	102	9.96	0.142	74.00	2.16	0.34
WAVE	17/11/2022 18:34	0.04	12.80	298	9.931	0.158	77.00	2.13	0.31
WAVE	17/11/2022 18:44	0.11	2.90	78	9.915	0.156	77.00	2.12	0.29
WAVE	17/11/2022 18:54	0.06	16.00	130	9.891	0.157	76.00	2.09	0.27
WAVE	17/11/2022 19:04	0.07	4.30	94	9.868	0.175	77.00	2.07	0.25
WAVE	17/11/2022 19:14	0.12	3.00	346	9.841	0.152	71.00	2.04	0.22
WAVE	17/11/2022 19:24	0.17	2.90	290	9.814	0.184	78.00	2.01	0.19
WAVE	17/11/2022 19:34	0.14	2.10	70	9.78	0.18	74.00	1.98	0.16
WAVE	17/11/2022 19:44	0.06	5.30	238	9.747	0.192	75.00	1.95	0.13
WAVE	17/11/2022 19:54	0.05	12.80	22	9.713	0.198	79.00	1.91	0.09
WAVE	17/11/2022 20:04	0.03	12.80	310	9.689	0.208	71.00	1.89	0.07
WAVE	17/11/2022 20:14	0.04	4.60	218	9.659	0.213	69.00	1.86	0.04
WAVE	17/11/2022 20:24	0.09	3.00	106	9.634	0.223	71.00	1.83	0.01
WAVE	17/11/2022 20:34	0.07	3.20	126	9.608	0.215	72.00	1.81	-0.01
WAVE	17/11/2022 20:44	0.03	9.10	270	9.57	0.222	74.00	1.77	-0.05
WAVE	17/11/2022 20:54	0.06	2.90	71	9.545	0.219	75.00	1.75	-0.08
WAVE	17/11/2022 21:04	0.11	2.80	88	9.505	0.233	71.00	1.71	-0.11
WAVE	17/11/2022 21:14	0.04	9.10	330	9.47	0.241	74.00	1.67	-0.15
WAVE	17/11/2022 21:24	0.12	2.30	310	9.431	0.216	68.00	1.63	-0.19
WAVE	17/11/2022 21:34	0.04	9.10	28	9.397	0.211	78.00	1.60	-0.22
WAVE	17/11/2022 21:44	0.05	9.10	110	9.36	0.22	73.00	1.56	-0.26
WAVE	17/11/2022 21:54	0.07	16.00	28	9.316	0.21	70.00	1.52	-0.30
WAVE	17/11/2022 22:04	0.04	10.70	90	9.301	0.215	67.00	1.50	-0.32
WAVE	17/11/2022 22:14	0.08	3.60	290	9.273	0.222	65.00	1.47	-0.35
WAVE	17/11/2022 22:24	0.05	9.10	10	9.246	0.207	54.00	1.45	-0.37
WAVE	17/11/2022 22:34	0.03	12.80	6	9.218	0.224	62.00	1.42	-0.40
WAVE	17/11/2022 22:44	0.03	9.10	282	9.191	0.224	61.00	1.39	-0.43
WAVE	17/11/2022 22:54	0.03	16.00	314	9.164	0.2	66.00	1.36	-0.46
WAVE	17/11/2022 23:04	0.04	3.80	142	9.148	0.194	67.00	1.35	-0.47
WAVE	17/11/2022 23:14	0.04	16.00	30	9.135	0.174	63.00	1.34	-0.49
WAVE	17/11/2022 23:24	0.04	21.30	28	9.125	0.157	62.00	1.33	-0.50
WAVE	17/11/2022 23:34	0.03	16.00	214	9.126	0.115	65.00	1.33	-0.49
WAVE	17/11/2022 23:44	0.03	16.00	203	9.124	0.083	206.00	1.32	-0.50
WAVE	18/11/2022 00:04	0.20	3.00	101	9.119	0.056	71.00	1.32	-0.50
WAVE	18/11/2022 00:14	0.25	2.10	130	9.129	0.03	75.00	1.33	-0.49
WAVE	18/11/2022 00:24	0.09	3.60	132	9.14	0.015	301.00	1.34	-0.48
WAVE	18/11/2022 00:34	0.03	12.80	118	9.167	0.038	319.00	1.37	-0.45
WAVE	18/11/2022 00:44	0.14	2.30	28	9.18	0.058	295.00	1.38	-0.44
WAVE	18/11/2022 00:54	0.05	8.00	350	9.21	0.081	268.00	1.41	-0.41
WAVE	18/11/2022 01:04	0.03	21.30	66	9.24	0.085	279.00	1.44	-0.38
WAVE	18/11/2022 01:14	0.02	21.30	28	9.267	0.087	267.00	1.47	-0.35
WAVE	18/11/2022 01:24	0.09	3.40	234	9.292	0.095	272.00	1.49	-0.33
WAVE	18/11/2022 01:34	0.03	12.80	226	9.329	0.07	259.00	1.53	-0.29
WAVE	18/11/2022 01:44	0.05	6.40	190	9.362	0.076	233.00	1.56	-0.26
WAVE	18/11/2022 01:54	0.13	10.70	142	9.392	0.084	234.00	1.59	-0.23
WAVE	18/11/2022 02:04	0.07	3.00	142	9.428	0.105	246.00	1.63	-0.19
WAVE	18/11/2022 02:14	0.03	12.80	354	9.465	0.114	269.00	1.67	-0.16
WAVE	18/11/2022 02:24	0.03	9.10	28	9.494	0.103	257.00	1.69	-0.13
WAVE	18/11/2022 02:34	0.06	3.40	118	9.534	0.083	264.00	1.73	-0.09
WAVE	18/11/2022 02:44	0.03	9.10	274	9.57	0.083	237.00	1.77	-0.05
WAVE	18/11/2022 02:54	0.02	12.80	278	9.609	0.093	262.00	1.81	-0.01
WAVE	18/11/2022 03:04	0.12	2.10	338	9.635	0.083	265.00	1.84	0.01
WAVE	18/11/2022 03:14	0.06	3.80	310	9.674	0.065	273.00	1.87	0.05
WAVE	18/11/2022 03:24	0.10	21.30	206	9.757	0.104	276.00	1.96	0.14

Name	Date Time	Significant Height(m)	Peak Time(sec)	Peak Direction (degree)	ADCP Depth(m)	Current Speed(m/s)	Current Direction (degree)	water level reference to CD	water level reference to 1.82 SHD
WAVE	18/11/2022 03:34	0.04	9.10	28	9.746	0.084	293.00	1.95	0.13
WAVE	18/11/2022 03:44	0.07	3.00	110	9.789	0.089	266.00	1.99	0.17
WAVE	18/11/2022 03:54	0.05	21.30	274	9.827	0.104	269.00	2.03	0.21
WAVE	18/11/2022 04:04	0.04	4.60	28	9.87	0.107	271.00	2.07	0.25
WAVE	18/11/2022 04:14	0.18	2.30	214	9.904	0.12	273.00	2.10	0.28
WAVE	18/11/2022 04:24	0.06	9.10	138	9.947	0.145	275.00	2.15	0.33
WAVE	18/11/2022 04:34	0.11	2.90	282	9.991	0.148	268.00	2.19	0.37
WAVE	18/11/2022 04:44	0.07	8.00	186	10.036	0.148	262.00	2.24	0.42
WAVE	18/11/2022 04:54	0.03	12.80	158	10.079	0.154	247.00	2.28	0.46
WAVE	18/11/2022 05:04	0.02	10.70	202	10.124	0.146	247.00	2.32	0.50
WAVE	18/11/2022 05:14	0.02	21.30	262	10.159	0.136	243.00	2.36	0.54
WAVE	18/11/2022 05:24	0.22	2.30	318	10.196	0.132	253.00	2.40	0.58
WAVE	18/11/2022 05:34	0.15	2.40	222	10.242	0.121	243.00	2.44	0.62
WAVE	18/11/2022 05:44	0.07	12.80	210	10.275	0.087	238.00	2.48	0.66
WAVE	18/11/2022 05:54	0.08	3.80	130	10.311	0.086	246.00	2.51	0.69
WAVE	18/11/2022 06:04	0.07	12.80	110	10.345	0.082	231.00	2.55	0.73
WAVE	18/11/2022 06:14	0.02	21.30	170	10.342	0.007	82.00	2.54	0.72
WAVE	18/11/2022 06:24	0.05	9.10	234	10.394	0.111	325.00	2.59	0.77
WAVE	18/11/2022 06:34	0.06	8.00	126	10.416	0.055	277.00	2.62	0.80
WAVE	18/11/2022 06:44	0.03	9.10	322	10.436	0.065	294.00	2.64	0.82
WAVE	18/11/2022 06:54	0.09	3.40	114	10.461	0.046	297.00	2.66	0.84
WAVE	18/11/2022 07:04	0.03	10.70	28	10.48	0.025	11.00	2.68	0.86
WAVE	18/11/2022 07:14	0.03	9.10	290	10.492	0.017	349.00	2.69	0.87
WAVE	18/11/2022 07:24	0.05	3.40	118	10.503	0.01	318.00	2.70	0.88
WAVE	18/11/2022 07:34	0.61	9.10	106	10.422	0.055	73.00	2.62	0.80
WAVE	18/11/2022 07:44	0.13	2.40	88	10.503	0.093	56.00	2.70	0.88
WAVE	18/11/2022 08:04	0.04	4.60	126	10.495	0.13	77.00	2.70	0.87
WAVE	18/11/2022 08:14	0.05	4.00	322	10.493	0.167	67.00	2.69	0.87
WAVE	18/11/2022 08:24	0.02	21.30	114	10.483	0.138	79.00	2.68	0.86
WAVE	18/11/2022 08:34	0.08	3.40	94	10.46	0.166	55.00	2.66	0.84
WAVE	18/11/2022 08:44	0.18	3.00	272	10.442	0.197	76.00	2.64	0.82
WAVE	18/11/2022 08:54	0.10	2.70	94	10.413	0.232	65.00	2.61	0.79
WAVE	18/11/2022 09:04	0.10	3.00	242	10.384	0.233	70.00	2.58	0.76
WAVE	18/11/2022 09:14	0.19	2.50	273	10.345	0.25	71.00	2.55	0.73
WAVE	18/11/2022 09:24	0.04	7.10	270	10.309	0.185	71.00	2.51	0.69
WAVE	18/11/2022 09:34	0.13	4.00	224	10.272	0.236	81.00	2.47	0.65
WAVE	18/11/2022 09:44	0.05	16.00	110	10.222	0.228	73.00	2.42	0.60
WAVE	18/11/2022 09:54	0.23	2.20	256	10.183	0.273	75.00	2.38	0.56
WAVE	18/11/2022 10:14	0.02	16.00	290	10.094	0.26	77.00	2.29	0.47
WAVE	18/11/2022 10:24	0.03	10.70	2	10.049	0.295	68.00	2.25	0.43
WAVE	18/11/2022 10:34	0.06	3.80	62	10.017	0.264	75.00	2.22	0.40
WAVE	18/11/2022 10:44	0.03	9.10	126	9.985	0.22	78.00	2.19	0.37
WAVE	18/11/2022 10:54	0.13	2.60	310	9.949	0.24	81.00	2.15	0.33
WAVE	18/11/2022 11:04	0.04	9.10	234	9.907	0.222	79.00	2.11	0.29
WAVE	18/11/2022 11:14	0.22	10.70	250	9.87	0.238	78.00	2.07	0.25
WAVE	18/11/2022 11:24	0.32	3.40	126	9.857	0.198	74.00	2.06	0.24
WAVE	18/11/2022 11:34	0.07	2.90	28	9.845	0.189	85.00	2.05	0.23
WAVE	18/11/2022 11:44	0.16	3.80	87	9.826	0.183	75.00	2.03	0.21
WAVE	18/11/2022 11:54	0.13	3.40	126	9.815	0.155	80.00	2.02	0.20
WAVE	18/11/2022 12:04	0.03	21.30	28	9.806	0.157	88.00	2.01	0.19
WAVE	18/11/2022 12:14	0.09	2.90	106	9.797	0.124	93.00	2.00	0.18
WAVE	18/11/2022 12:24	0.18	16.00	126	9.808	0.129	82.00	2.01	0.19
WAVE	18/11/2022 12:34	0.08	3.40	102	9.789	0.107	79.00	1.99	0.17
WAVE	18/11/2022 12:44	0.06	4.30	70	9.79	0.089	45.00	1.99	0.17
WAVE	18/11/2022 12:54	0.02	9.10	74	9.8	0.037	87.00	2.00	0.18
WAVE	18/11/2022 13:04	0.03	10.70	18	9.807	0.021	155.00	2.01	0.19
WAVE	18/11/2022 13:14	0.18	3.60	222	9.819	0.038	115.00	2.02	0.20
WAVE	18/11/2022 13:24	0.14	3.20	86	9.863	0.084	75.00	2.06	0.24
WAVE	18/11/2022 13:34	0.10	3.00	110	9.837	0.011	249.00	2.04	0.22
WAVE	18/11/2022 13:44	0.05	3.60	290	9.842	0.04	296.00	2.04	0.22
WAVE	18/11/2022 13:54	0.04	16.00	28	9.863	0.033	248.00	2.06	0.24
WAVE	18/11/2022 14:04	0.11	2.80	66	9.871	0.048	289.00	2.07	0.25
WAVE	18/11/2022 14:14	0.20	2.90	290	9.886	0.049	296.00	2.09	0.27
WAVE	18/11/2022 14:24	0.03	10.70	154	9.905	0.021	270.00	2.11	0.28

Name	Date Time	Significant Height(m)	Peak Time(sec)	Peak Direction (degree)	ADCP Depth(m)	Current Speed(m/s)	Current Direction (degree)	water level reference to CD	water level reference to 1.82 SHD
WAVE	18/11/2022 14:34	0.12	2.90	114	9.913	0.037	269.00	2.11	0.29
WAVE	18/11/2022 14:44	0.14	2.90	126	9.916	0.033	266.00	2.12	0.30
WAVE	18/11/2022 14:54	0.12	2.90	238	9.921	0.022	317.00	2.12	0.30
WAVE	18/11/2022 15:04	0.05	10.70	210	9.926	0.028	316.00	2.13	0.31
WAVE	18/11/2022 15:14	0.13	2.90	108	9.941	0.023	27.00	2.14	0.32
WAVE	18/11/2022 15:24	0.23	2.10	346	9.947	0.049	58.00	2.15	0.33
WAVE	18/11/2022 15:34	0.16	2.10	86	9.961	0.044	64.00	2.16	0.34
WAVE	18/11/2022 15:44	0.09	3.00	282	9.955	0.063	74.00	2.16	0.34
WAVE	18/11/2022 15:54	0.07	9.10	294	9.954	0.068	93.00	2.15	0.33
WAVE	18/11/2022 16:04	0.07	5.80	138	9.956	0.064	81.00	2.16	0.34
WAVE	18/11/2022 16:14	0.13	2.90	314	9.965	0.051	65.00	2.17	0.35
WAVE	18/11/2022 16:24	0.05	8.00	138	9.957	0.068	81.00	2.16	0.34
WAVE	18/11/2022 16:34	0.45	9.10	106	10.021	0.007	32.00	2.22	0.40
WAVE	18/11/2022 16:44	0.04	4.60	82	9.974	0.061	99.00	2.17	0.35
WAVE	18/11/2022 16:54	0.14	12.80	290	10.002	0.041	124.00	2.20	0.38
WAVE	18/11/2022 17:04	0.07	3.00	70	9.991	0.055	126.00	2.19	0.37
WAVE	18/11/2022 17:14	0.06	4.00	124	10.009	0.051	125.00	2.21	0.39
WAVE	18/11/2022 17:24	0.18	2.30	166	10.017	0.023	184.00	2.22	0.40
WAVE	18/11/2022 17:34	0.10	3.20	146	10.031	0.046	264.00	2.23	0.41
WAVE	18/11/2022 17:44	0.09	2.90	110	10.048	0.056	270.00	2.25	0.43
WAVE	18/11/2022 17:54	0.13	4.00	90	10.056	0.059	275.00	2.26	0.44
WAVE	18/11/2022 18:04	0.08	3.40	218	10.068	0.057	269.00	2.27	0.45
WAVE	18/11/2022 18:14	0.06	21.30	214	10.072	0.057	280.00	2.27	0.45
WAVE	18/11/2022 18:24	0.03	9.10	242	10.085	0.038	274.00	2.29	0.47
WAVE	18/11/2022 18:34	0.12	2.70	122	10.09	0.07	285.00	2.29	0.47
WAVE	18/11/2022 18:44	0.23	2.90	86	10.097	0.043	288.00	2.30	0.48
WAVE	18/11/2022 18:54	0.03	9.10	334	10.105	0.022	294.00	2.31	0.49
WAVE	18/11/2022 19:04	0.24	2.70	266	10.111	0.003	32.00	2.31	0.49
WAVE	18/11/2022 19:14	0.07	3.60	214	10.121	0.016	39.00	2.32	0.50
WAVE	18/11/2022 19:24	0.08	9.10	78	10.126	0.023	32.00	2.33	0.51
WAVE	18/11/2022 19:34	0.09	3.00	90	10.123	0.023	54.00	2.32	0.50
WAVE	18/11/2022 19:44	0.04	12.80	234	10.109	0.059	78.00	2.31	0.49
WAVE	18/11/2022 19:54	0.03	12.80	294	10.119	0.071	71.00	2.32	0.50
WAVE	18/11/2022 20:04	0.08	16.00	30	10.102	0.067	75.00	2.30	0.48
WAVE	18/11/2022 20:14	0.02	10.70	28	10.089	0.097	77.00	2.29	0.47
WAVE	18/11/2022 20:34	0.02	12.80	202	10.045	0.144	77.00	2.25	0.43
WAVE	18/11/2022 20:44	0.04	21.30	334	10.023	0.164	75.00	2.22	0.40
WAVE	18/11/2022 20:54	0.05	6.40	18	10.001	0.195	81.00	2.20	0.38
WAVE	18/11/2022 21:04	0.03	9.10	314	9.96	0.207	82.00	2.16	0.34
WAVE	18/11/2022 21:14	0.22	3.80	116	9.928	0.253	81.00	2.13	0.31
WAVE	18/11/2022 21:24	0.04	12.80	28	9.9	0.25	77.00	2.10	0.28
WAVE	18/11/2022 21:34	0.04	5.80	78	9.85	0.269	75.00	2.05	0.23
WAVE	18/11/2022 21:44	0.03	9.10	286	9.806	0.266	74.00	2.01	0.19
WAVE	18/11/2022 21:54	0.02	12.80	222	9.757	0.292	74.00	1.96	0.14
WAVE	18/11/2022 22:04	0.02	9.10	28	9.714	0.288	73.00	1.91	0.09
WAVE	18/11/2022 22:14	0.03	9.10	142	9.658	0.275	70.00	1.86	0.04
WAVE	18/11/2022 22:24	0.03	12.80	58	9.62	0.323	81.00	1.82	0.00
WAVE	18/11/2022 22:34	0.05	9.10	238	9.569	0.31	67.00	1.77	-0.05
WAVE	18/11/2022 22:44	0.03	16.00	28	9.519	0.289	65.00	1.72	-0.10
WAVE	18/11/2022 22:54	0.08	12.80	210	9.479	0.287	64.00	1.68	-0.14
WAVE	18/11/2022 23:04	0.07	10.70	150	9.422	0.292	66.00	1.62	-0.20
WAVE	18/11/2022 23:14	0.05	8.00	226	9.378	0.255	68.00	1.58	-0.24
WAVE	18/11/2022 23:24	0.03	9.10	28	9.327	0.239	74.00	1.53	-0.29
WAVE	18/11/2022 23:34	0.07	9.10	262	9.282	0.254	68.00	1.48	-0.34
WAVE	18/11/2022 23:44	0.08	3.20	118	9.242	0.246	66.00	1.44	-0.38
WAVE	18/11/2022 23:54	0.02	10.70	246	9.216	0.257	66.00	1.42	-0.40
WAVE	19/11/2022 00:04	0.11	2.70	294	9.187	0.218	62.00	1.39	-0.43
WAVE	19/11/2022 00:14	0.06	5.30	30	9.168	0.198	74.00	1.37	-0.45
WAVE	19/11/2022 00:24	0.23	2.20	302	9.145	0.203	80.00	1.35	-0.48
WAVE	19/11/2022 00:34	0.06	3.20	246	9.123	0.15	65.00	1.32	-0.50
WAVE	19/11/2022 00:44	0.02	9.10	110	9.101	0.151	50.00	1.30	-0.52
WAVE	19/11/2022 01:04	0.14	2.10	46	9.091	0.06	45.00	1.29	-0.53
WAVE	19/11/2022 01:14	0.02	10.70	28	9.107	0.051	2.00	1.31	-0.51
WAVE	19/11/2022 01:24	0.08	12.80	142	9.116	0.041	344.00	1.32	-0.50

Name	Date Time	Significant Height(m)	Peak Time(sec)	Peak Direction (degree)	ADCP Depth(m)	Current Speed(m/s)	Current Direction (degree)	water level reference to CD	water level reference to 1.82 SHD
WAVE	19/11/2022 01:34	0.44	10.70	28	9.184	0.037	343.00	1.38	-0.44
WAVE	19/11/2022 01:44	0.20	2.40	2	9.141	0.044	283.00	1.34	-0.48
WAVE	19/11/2022 01:54	0.03	10.70	250	9.159	0.061	271.00	1.36	-0.46
WAVE	19/11/2022 02:04	0.10	3.00	294	9.173	0.114	280.00	1.37	-0.45
WAVE	19/11/2022 02:14	0.03	9.10	28	9.19	0.144	270.00	1.39	-0.43
WAVE	19/11/2022 02:24	0.05	8.00	158	9.226	0.163	265.00	1.43	-0.39
WAVE	19/11/2022 02:34	0.09	9.10	28	9.264	0.15	261.00	1.46	-0.36
WAVE	19/11/2022 02:44	0.02	12.80	28	9.3	0.157	262.00	1.50	-0.32
WAVE	19/11/2022 02:54	0.04	9.10	154	9.346	0.161	270.00	1.55	-0.27
WAVE	19/11/2022 03:04	0.04	7.10	146	9.387	0.154	257.00	1.59	-0.23
WAVE	19/11/2022 03:14	0.04	9.10	2	9.427	0.131	253.00	1.63	-0.19
WAVE	19/11/2022 03:24	0.02	9.10	170	9.442	0.129	244.00	1.64	-0.18
WAVE	19/11/2022 03:34	0.08	3.20	302	9.493	0.103	240.00	1.69	-0.13
WAVE	19/11/2022 03:44	0.05	8.00	254	9.531	0.125	235.00	1.73	-0.09
WAVE	19/11/2022 03:54	0.13	2.20	322	9.575	0.11	236.00	1.78	-0.05
WAVE	19/11/2022 04:14	0.02	9.10	286	9.658	0.137	262.00	1.86	0.04
WAVE	19/11/2022 04:24	0.02	9.10	318	9.7	0.109	258.00	1.90	0.08
WAVE	19/11/2022 04:34	0.08	16.00	254	9.745	0.12	258.00	1.95	0.12
WAVE	19/11/2022 04:44	0.06	6.40	146	9.778	0.132	268.00	1.98	0.16
WAVE	19/11/2022 04:54	0.02	10.70	230	9.828	0.166	285.00	2.03	0.21
WAVE	19/11/2022 05:04	0.37	10.70	122	9.912	0.182	276.00	2.11	0.29
WAVE	19/11/2022 05:14	0.43	9.10	338	9.959	0.181	275.00	2.16	0.34
WAVE	19/11/2022 05:24	0.05	8.00	298	9.974	0.21	258.00	2.17	0.35
WAVE	19/11/2022 05:34	0.09	3.20	226	10.029	0.226	264.00	2.23	0.41
WAVE	19/11/2022 05:44	0.04	21.30	198	10.079	0.226	258.00	2.28	0.46
WAVE	19/11/2022 05:54	0.04	9.10	330	10.129	0.229	259.00	2.33	0.51
WAVE	19/11/2022 06:04	0.07	12.80	86	10.183	0.248	260.00	2.38	0.56
WAVE	19/11/2022 06:14	0.10	2.40	26	10.232	0.238	254.00	2.43	0.61
WAVE	19/11/2022 06:24	0.03	9.10	102	10.279	0.247	254.00	2.48	0.66
WAVE	19/11/2022 06:44	0.08	12.80	28	10.366	0.224	256.00	2.57	0.75
WAVE	19/11/2022 06:54	0.13	2.20	330	10.418	0.149	257.00	2.62	0.80
WAVE	19/11/2022 07:04	0.03	21.30	174	10.452	0.079	268.00	2.65	0.83
WAVE	19/11/2022 07:14	0.04	8.00	146	10.489	0.089	254.00	2.69	0.87
WAVE	19/11/2022 07:24	0.04	9.10	306	10.52	0.091	250.00	2.72	0.90
WAVE	19/11/2022 07:34	0.03	9.10	198	10.546	0.099	266.00	2.75	0.93
WAVE	19/11/2022 07:44	0.03	9.10	146	10.572	0.083	248.00	2.77	0.95
WAVE	19/11/2022 07:54	0.13	2.90	94	10.598	0.073	259.00	2.80	0.98
WAVE	19/11/2022 08:04	0.24	2.70	97	10.552	0.09	266.00	2.75	0.93
WAVE	19/11/2022 08:14	0.16	2.90	110	10.626	0.045	277.00	2.83	1.01
WAVE	19/11/2022 08:24	0.06	3.20	122	10.641	0.058	277.00	2.84	1.02
WAVE	19/11/2022 08:34	0.10	2.80	106	10.641	0.046	283.00	2.84	1.02
WAVE	19/11/2022 08:44	0.04	16.00	122	10.643	0.047	292.00	2.84	1.02
WAVE	19/11/2022 08:54	0.08	9.10	122	10.647	0.025	304.00	2.85	1.03
WAVE	19/11/2022 09:04	0.19	2.90	103	10.639	0.034	71.00	2.84	1.02
WAVE	19/11/2022 09:14	0.21	3.80	104	10.632	0.095	60.00	2.83	1.01
WAVE	19/11/2022 09:24	0.14	3.60	126	10.624	0.131	63.00	2.82	1.00
WAVE	19/11/2022 09:34	0.07	21.30	28	10.602	0.147	59.00	2.80	0.98
WAVE	19/11/2022 09:44	0.18	2.90	94	10.574	0.129	58.00	2.77	0.95
WAVE	19/11/2022 09:54	0.03	16.00	342	10.53	0.171	56.00	2.73	0.91
WAVE	19/11/2022 10:04	0.03	9.10	166	10.5	0.166	63.00	2.70	0.88
WAVE	19/11/2022 10:14	0.04	10.70	22	10.465	0.207	54.00	2.67	0.85
WAVE	19/11/2022 10:24	0.02	21.30	28	10.422	0.291	52.00	2.62	0.80
WAVE	19/11/2022 10:34	0.09	2.70	100	10.381	0.273	55.00	2.58	0.76
WAVE	19/11/2022 10:44	0.15	4.30	96	10.332	0.319	64.00	2.53	0.71
WAVE	19/11/2022 10:54	0.03	21.30	266	10.285	0.233	80.00	2.49	0.67
WAVE	19/11/2022 11:04	0.09	3.20	222	10.232	0.254	77.00	2.43	0.61
WAVE	19/11/2022 11:14	0.19	3.20	88	10.169	0.26	76.00	2.37	0.55
WAVE	19/11/2022 11:24	0.10	2.90	28	10.109	0.257	83.00	2.31	0.49
WAVE	19/11/2022 11:34	0.05	12.80	138	10.048	0.282	76.00	2.25	0.43
WAVE	19/11/2022 11:44	0.08	3.60	126	10	0.331	74.00	2.20	0.38
WAVE	19/11/2022 11:54	0.18	3.40	194	9.933	0.342	73.00	2.13	0.31
WAVE	19/11/2022 12:04	0.06	3.00	68	9.889	0.282	71.00	2.09	0.27
WAVE	19/11/2022 12:14	0.08	2.90	102	9.829	0.268	67.00	2.03	0.21
WAVE	19/11/2022 12:24	0.11	3.40	94	9.79	0.337	60.00	1.99	0.17

Name	Date Time	Significant Height(m)	Peak Time(sec)	Peak Direction (degree)	ADCP Depth(m)	Current Speed(m/s)	Current Direction (degree)	water level reference to CD	water level reference to 1.82 SHD
WAVE	19/11/2022 12:34	0.11	3.00	74	9.758	0.341	65.00	1.96	0.14
WAVE	19/11/2022 12:44	0.08	3.60	106	9.717	0.305	76.00	1.92	0.10
WAVE	19/11/2022 12:54	0.09	2.90	166	9.707	0.21	84.00	1.91	0.09
WAVE	19/11/2022 13:04	0.08	2.80	308	9.687	0.19	90.00	1.89	0.07
WAVE	19/11/2022 13:14	0.03	10.70	6	9.676	0.126	97.00	1.88	0.06
WAVE	19/11/2022 13:24	0.19	2.90	94	9.668	0.13	109.00	1.87	0.05
WAVE	19/11/2022 13:34	0.45	9.10	118	9.681	0.12	114.00	1.88	0.06
WAVE	19/11/2022 13:44	0.17	2.80	118	9.686	0.09	113.00	1.89	0.07
WAVE	19/11/2022 13:54	0.04	12.80	138	9.668	0.049	143.00	1.87	0.05
WAVE	19/11/2022 14:04	0.10	2.90	110	9.672	0.034	200.00	1.87	0.05
WAVE	19/11/2022 14:14	0.11	2.80	282	9.686	0.052	220.00	1.89	0.07
WAVE	19/11/2022 14:24	0.55	9.10	110	9.734	0.061	225.00	1.93	0.11
WAVE	19/11/2022 14:34	0.14	3.00	110	9.731	0.099	256.00	1.93	0.11
WAVE	19/11/2022 14:44	0.02	10.70	66	9.739	0.065	241.00	1.94	0.12
WAVE	19/11/2022 14:54	0.03	16.00	338	9.76	0.055	248.00	1.96	0.14
WAVE	19/11/2022 15:04	0.09	2.80	122	9.767	0.168	283.00	1.97	0.15
WAVE	19/11/2022 15:14	0.17	12.80	102	9.832	0.127	272.00	2.03	0.21
WAVE	19/11/2022 15:24	0.04	12.80	326	9.803	0.096	278.00	2.00	0.18
WAVE	19/11/2022 15:34	0.13	2.60	210	9.806	0.067	265.00	2.01	0.19
WAVE	19/11/2022 15:44	0.09	4.00	102	9.827	0.07	273.00	2.03	0.21
WAVE	19/11/2022 15:54	0.11	2.90	110	9.843	0.113	280.00	2.04	0.22
WAVE	19/11/2022 16:14	0.17	2.90	94	9.866	0.09	269.00	2.07	0.25
WAVE	19/11/2022 16:24	0.09	3.40	100	9.899	0.112	269.00	2.10	0.28
WAVE	19/11/2022 16:34	0.04	9.10	358	9.912	0.112	267.00	2.11	0.29
WAVE	19/11/2022 16:44	0.10	2.90	98	9.942	0.115	257.00	2.14	0.32
WAVE	19/11/2022 16:54	0.08	3.80	110	9.972	0.12	262.00	2.17	0.35
WAVE	19/11/2022 17:04	0.13	3.80	118	9.992	0.134	249.00	2.19	0.37
WAVE	19/11/2022 17:14	0.08	3.60	210	10.017	0.12	249.00	2.22	0.40
WAVE	19/11/2022 17:24	0.05	3.80	274	10.038	0.141	247.00	2.24	0.42
WAVE	19/11/2022 17:34	0.10	3.00	118	10.056	0.118	249.00	2.26	0.44
WAVE	19/11/2022 17:44	0.09	2.80	110	10.077	0.112	251.00	2.28	0.46
WAVE	19/11/2022 17:54	0.17	2.80	110	10.115	0.116	253.00	2.32	0.50
WAVE	19/11/2022 18:04	0.10	3.60	110	10.145	0.113	244.00	2.35	0.53
WAVE	19/11/2022 18:14	0.16	2.90	290	10.191	0.118	250.00	2.39	0.57
WAVE	19/11/2022 18:24	0.20	9.10	322	10.238	0.13	287.00	2.44	0.62
WAVE	19/11/2022 18:34	0.04	10.70	28	10.257	0.114	266.00	2.46	0.64
WAVE	19/11/2022 18:44	0.23	2.30	18	10.282	0.11	267.00	2.48	0.66
WAVE	19/11/2022 18:54	0.07	9.10	162	10.296	0.096	261.00	2.50	0.68
WAVE	19/11/2022 19:04	0.02	16.00	28	10.311	0.096	275.00	2.51	0.69
WAVE	19/11/2022 19:14	0.07	5.30	226	10.328	0.101	272.00	2.53	0.71
WAVE	19/11/2022 19:24	0.03	10.70	28	10.346	0.096	273.00	2.55	0.73
WAVE	19/11/2022 19:34	0.07	3.80	122	10.354	0.044	273.00	2.55	0.73
WAVE	19/11/2022 19:44	0.06	3.80	298	10.374	0.031	249.00	2.57	0.75
WAVE	19/11/2022 19:54	0.10	2.80	226	10.378	0.016	269.00	2.58	0.76
WAVE	19/11/2022 20:04	0.04	12.80	118	10.371	0.029	24.00	2.57	0.75
WAVE	19/11/2022 20:14	0.02	9.10	234	10.361	0.046	79.00	2.56	0.74
WAVE	19/11/2022 20:24	0.13	2.00	254	10.352	0.081	80.00	2.55	0.73
WAVE	19/11/2022 20:34	0.03	9.10	54	10.344	0.031	64.00	2.54	0.72
WAVE	19/11/2022 20:44	0.06	9.10	28	10.345	0.056	81.00	2.55	0.73
WAVE	19/11/2022 20:54	0.08	2.90	106	10.343	0.074	63.00	2.54	0.72
WAVE	19/11/2022 21:04	0.06	10.70	14	10.331	0.104	73.00	2.53	0.71
WAVE	19/11/2022 21:14	0.04	12.80	146	10.319	0.111	77.00	2.52	0.70
WAVE	19/11/2022 21:24	0.04	16.00	214	10.284	0.108	75.00	2.48	0.66
WAVE	19/11/2022 21:34	0.03	12.80	28	10.241	0.123	73.00	2.44	0.62
WAVE	19/11/2022 21:44	0.03	10.70	28	10.201	0.16	68.00	2.40	0.58
WAVE	19/11/2022 21:54	0.04	12.80	126	10.148	0.197	67.00	2.35	0.53
WAVE	19/11/2022 22:04	0.12	10.70	174	10.059	0.212	67.00	2.26	0.44
WAVE	19/11/2022 22:14	0.09	2.70	138	10.066	0.239	72.00	2.27	0.45
WAVE	19/11/2022 22:24	0.12	2.60	306	10.013	0.275	70.00	2.21	0.39
WAVE	19/11/2022 22:34	0.20	2.90	294	9.971	0.286	70.00	2.17	0.35
WAVE	19/11/2022 22:44	0.03	21.30	190	9.922	0.284	73.00	2.12	0.30
WAVE	19/11/2022 22:54	0.04	10.70	278	9.866	0.304	77.00	2.07	0.25
WAVE	19/11/2022 23:04	0.05	7.10	28	9.809	0.327	68.00	2.01	0.19
WAVE	19/11/2022 23:14	0.05	8.00	290	9.755	0.318	67.00	1.96	0.14

Name	Date Time	Significant Height(m)	Peak Time(sec)	Peak Direction (degree)	ADCP Depth(m)	Current Speed(m/s)	Current Direction (degree)	water level reference to CD	water level reference to 1.82 SHD
WAVE	19/11/2022 23:24	0.07	3.80	246	9.701	0.295	66.00	1.90	0.08
WAVE	19/11/2022 23:34	0.05	21.30	102	9.651	0.31	64.00	1.85	0.03
WAVE	19/11/2022 23:44	0.02	16.00	338	9.599	0.293	58.00	1.80	-0.02
WAVE	19/11/2022 23:54	0.04	10.70	94	9.544	0.306	62.00	1.74	-0.08
WAVE	20/11/2022 00:04	0.06	12.80	174	9.496	0.313	54.00	1.70	-0.12
WAVE	20/11/2022 00:14	0.04	12.80	294	9.43	0.332	50.00	1.63	-0.19
WAVE	20/11/2022 00:24	0.04	7.10	222	9.376	0.303	54.00	1.58	-0.24
WAVE	20/11/2022 00:34	0.11	2.90	230	9.329	0.292	63.00	1.53	-0.29
WAVE	20/11/2022 00:44	0.14	3.20	134	9.277	0.223	63.00	1.48	-0.34
WAVE	20/11/2022 00:54	0.05	6.40	298	9.245	0.244	63.00	1.45	-0.38
WAVE	20/11/2022 01:04	0.03	9.10	170	9.211	0.231	67.00	1.41	-0.41
WAVE	20/11/2022 01:14	0.12	2.60	130	9.186	0.231	65.00	1.39	-0.43
WAVE	20/11/2022 01:24	0.08	6.40	28	9.16	0.186	75.00	1.36	-0.46
WAVE	20/11/2022 01:34	0.06	4.30	334	9.123	0.174	78.00	1.32	-0.50
WAVE	20/11/2022 01:44	0.11	9.10	282	9.098	0.159	82.00	1.30	-0.52
WAVE	20/11/2022 01:54	0.18	2.30	138	9.09	0.122	87.00	1.29	-0.53
WAVE	20/11/2022 02:04	0.16	10.70	298	9.107	0.109	102.00	1.31	-0.51
WAVE	20/11/2022 02:14	0.06	5.30	250	9.077	0.072	100.00	1.28	-0.54
WAVE	20/11/2022 02:24	0.07	3.80	242	9.081	0.024	131.00	1.28	-0.54
WAVE	20/11/2022 02:34	0.04	9.10	302	9.096	0.013	143.00	1.30	-0.52
WAVE	20/11/2022 02:44	0.21	2.30	330	9.117	0.041	274.00	1.32	-0.50
WAVE	20/11/2022 02:54	0.03	21.30	150	9.141	0.085	256.00	1.34	-0.48
WAVE	20/11/2022 03:04	0.09	3.40	166	9.169	0.124	253.00	1.37	-0.45
WAVE	20/11/2022 03:14	0.06	4.60	170	9.186	0.186	237.00	1.39	-0.43
WAVE	20/11/2022 03:24	0.03	10.70	274	9.217	0.203	251.00	1.42	-0.40
WAVE	20/11/2022 03:54	0.11	2.70	126	9.298	0.228	259.00	1.50	-0.32
WAVE	20/11/2022 04:04	0.03	16.00	346	9.331	0.215	264.00	1.53	-0.29
WAVE	20/11/2022 04:14	0.07	10.70	62	9.371	0.186	274.00	1.57	-0.25
WAVE	20/11/2022 04:24	0.08	3.00	134	9.415	0.168	267.00	1.62	-0.21
WAVE	20/11/2022 04:34	0.06	9.10	286	9.446	0.145	266.00	1.65	-0.17
WAVE	20/11/2022 04:44	0.15	2.70	98	9.493	0.15	275.00	1.69	-0.13
WAVE	20/11/2022 04:54	0.12	3.60	86	9.538	0.13	264.00	1.74	-0.08
WAVE	20/11/2022 05:04	0.09	3.20	130	9.583	0.137	266.00	1.78	-0.04
WAVE	20/11/2022 05:14	0.10	3.20	28	9.644	0.131	268.00	1.84	0.02
WAVE	20/11/2022 05:24	0.07	3.80	230	9.691	0.185	263.00	1.89	0.07
WAVE	20/11/2022 05:34	0.03	9.10	346	9.743	0.19	263.00	1.94	0.12
WAVE	20/11/2022 05:44	0.02	10.70	126	9.798	0.22	262.00	2.00	0.18
WAVE	20/11/2022 05:54	0.06	4.90	28	9.85	0.267	253.00	2.05	0.23
WAVE	20/11/2022 06:04	0.03	9.10	302	9.915	0.286	257.00	2.12	0.29
WAVE	20/11/2022 06:14	0.04	10.70	28	9.978	0.288	258.00	2.18	0.36
WAVE	20/11/2022 06:24	0.04	9.10	28	10.037	0.273	258.00	2.24	0.42
WAVE	20/11/2022 06:34	0.08	3.80	158	10.103	0.311	265.00	2.30	0.48
WAVE	20/11/2022 06:44	0.07	3.40	118	10.176	0.312	261.00	2.38	0.56
WAVE	20/11/2022 06:54	0.17	2.40	304	10.247	0.322	261.00	2.45	0.63
WAVE	20/11/2022 07:04	0.12	3.20	102	10.314	0.308	260.00	2.51	0.69
WAVE	20/11/2022 07:14	0.18	3.00	121	10.382	0.271	249.00	2.58	0.76
WAVE	20/11/2022 07:24	0.08	2.90	54	10.436	0.265	263.00	2.64	0.82
WAVE	20/11/2022 07:34	0.14	2.90	276	10.488	0.261	258.00	2.69	0.87
WAVE	20/11/2022 07:44	0.08	2.70	118	10.542	0.278	265.00	2.74	0.92
WAVE	20/11/2022 07:54	0.06	10.70	28	10.575	0.296	262.00	2.78	0.95
WAVE	20/11/2022 08:04	0.13	3.00	282	10.613	0.291	260.00	2.81	0.99
WAVE	20/11/2022 08:14	0.05	9.10	58	10.643	0.252	260.00	2.84	1.02
WAVE	20/11/2022 08:24	0.03	9.10	22	10.675	0.275	266.00	2.88	1.06
WAVE	20/11/2022 08:34	0.63	16.00	178	10.661	0.236	261.00	2.86	1.04
WAVE	20/11/2022 08:44	0.12	2.80	114	10.718	0.157	247.00	2.92	1.10
WAVE	20/11/2022 08:54	0.22	3.40	100	10.71	0.118	230.00	2.91	1.09
WAVE	20/11/2022 09:04	0.03	10.70	350	10.704	0.123	239.00	2.90	1.08
WAVE	20/11/2022 09:14	0.17	2.60	80	10.701	0.065	222.00	2.90	1.08
WAVE	20/11/2022 09:24	0.14	2.80	98	10.686	0.068	139.00	2.89	1.07
WAVE	20/11/2022 09:34	0.13	2.70	270	10.671	0.043	49.00	2.87	1.05
WAVE	20/11/2022 09:44	0.13	2.60	226	10.649	0.103	92.00	2.85	1.03
WAVE	20/11/2022 09:54	0.09	3.60	102	10.62	0.173	77.00	2.82	1.00
WAVE	20/11/2022 10:04	0.03	16.00	286	10.58	0.179	81.00	2.78	0.96
WAVE	20/11/2022 10:14	0.12	3.20	114	10.548	0.196	75.00	2.75	0.93

Name	Date Time	Significant Height(m)	Peak Time(sec)	Peak Direction (degree)	ADCP Depth(m)	Current Speed(m/s)	Current Direction (degree)	water level reference to CD	water level reference to 1.82 SHD
WAVE	20/11/2022 10:34	0.03	16.00	302	10.45	0.299	58.00	2.65	0.83
WAVE	20/11/2022 10:44	0.16	2.90	90	10.402	0.245	64.00	2.60	0.78
WAVE	20/11/2022 10:54	0.32	3.00	277	10.34	0.268	57.00	2.54	0.72
WAVE	20/11/2022 11:04	0.08	3.20	98	10.283	0.207	63.00	2.48	0.66
WAVE	20/11/2022 11:14	0.10	3.00	298	10.223	0.226	61.00	2.42	0.60
WAVE	20/11/2022 11:24	0.06	21.30	90	10.16	0.309	55.00	2.36	0.54
WAVE	20/11/2022 11:34	0.08	2.90	50	10.088	0.29	62.00	2.29	0.47
WAVE	20/11/2022 11:44	0.11	3.60	270	10.025	0.395	66.00	2.23	0.41
WAVE	20/11/2022 11:54	0.05	3.60	110	9.962	0.37	68.00	2.16	0.34
WAVE	20/11/2022 12:04	0.09	3.00	56	9.898	0.356	61.00	2.10	0.28
WAVE	20/11/2022 12:14	0.18	2.80	278	9.841	0.333	61.00	2.04	0.22
WAVE	20/11/2022 12:24	0.21	2.60	285	9.79	0.302	60.00	1.99	0.17
WAVE	20/11/2022 12:34	0.05	10.70	182	9.735	0.279	64.00	1.94	0.12
WAVE	20/11/2022 12:44	0.10	2.90	86	9.682	0.322	61.00	1.88	0.06
WAVE	20/11/2022 12:54	0.26	3.20	314	9.634	0.303	60.00	1.83	0.01
WAVE	20/11/2022 13:04	0.07	3.00	114	9.582	0.321	55.00	1.78	-0.04
WAVE	20/11/2022 13:14	0.10	2.70	294	9.536	0.325	55.00	1.74	-0.08
WAVE	20/11/2022 13:24	0.17	2.80	302	9.495	0.268	67.00	1.70	-0.13
WAVE	20/11/2022 13:34	0.06	12.80	28	9.448	0.282	61.00	1.65	-0.17
WAVE	20/11/2022 13:44	0.21	2.70	277	9.413	0.238	61.00	1.61	-0.21
WAVE	20/11/2022 13:54	0.03	10.70	294	9.375	0.216	66.00	1.58	-0.25
WAVE	20/11/2022 14:04	0.07	2.80	118	9.344	0.2	70.00	1.54	-0.28
WAVE	20/11/2022 14:14	0.09	2.90	28	9.322	0.149	87.00	1.52	-0.30
WAVE	20/11/2022 14:24	0.23	2.10	258	9.311	0.132	96.00	1.51	-0.31
WAVE	20/11/2022 14:34	0.09	3.40	54	9.298	0.111	113.00	1.50	-0.32
WAVE	20/11/2022 14:44	0.09	3.00	66	9.296	0.082	106.00	1.50	-0.32
WAVE	20/11/2022 14:54	0.10	2.90	310	9.314	0.068	122.00	1.51	-0.31
WAVE	20/11/2022 15:04	0.16	2.90	290	9.289	0.05	188.00	1.49	-0.33
WAVE	20/11/2022 15:14	0.16	2.30	118	9.302	0.039	262.00	1.50	-0.32
WAVE	20/11/2022 15:24	0.28	2.20	28	9.304	0.066	242.00	1.50	-0.32
WAVE	20/11/2022 15:34	0.09	8.00	262	9.318	0.084	237.00	1.52	-0.30
WAVE	20/11/2022 15:44	0.13	3.00	302	9.343	0.104	246.00	1.54	-0.28
WAVE	20/11/2022 15:54	0.45	9.10	138	9.423	0.039	226.00	1.62	-0.20
WAVE	20/11/2022 16:04	0.16	2.90	112	9.407	0.061	238.00	1.61	-0.21
WAVE	20/11/2022 16:14	0.15	2.70	262	9.435	0.081	258.00	1.64	-0.18
WAVE	20/11/2022 16:24	0.13	3.40	95	9.464	0.131	242.00	1.66	-0.16
WAVE	20/11/2022 16:34	0.22	2.70	90	9.5	0.147	264.00	1.70	-0.12
WAVE	20/11/2022 16:44	0.11	2.90	289	9.538	0.151	253.00	1.74	-0.08
WAVE	20/11/2022 16:54	0.19	2.80	118	9.574	0.16	260.00	1.77	-0.05
WAVE	20/11/2022 17:04	0.15	2.80	271	9.606	0.196	257.00	1.81	-0.01
WAVE	20/11/2022 17:14	0.02	9.10	258	9.65	0.195	262.00	1.85	0.03
WAVE	20/11/2022 17:24	0.09	2.80	306	9.689	0.242	263.00	1.89	0.07
WAVE	20/11/2022 17:34	0.03	16.00	106	9.729	0.247	259.00	1.93	0.11
WAVE	20/11/2022 17:44	0.28	2.10	266	9.769	0.225	254.00	1.97	0.15
WAVE	20/11/2022 17:54	0.19	2.90	290	9.814	0.22	254.00	2.01	0.19
WAVE	20/11/2022 18:04	0.06	4.30	342	9.861	0.205	260.00	2.06	0.24
WAVE	20/11/2022 18:14	0.18	2.60	118	9.904	0.198	258.00	2.10	0.28
WAVE	20/11/2022 18:24	0.05	12.80	10	9.949	0.226	257.00	2.15	0.33
WAVE	20/11/2022 18:34	0.10	2.70	314	10.004	0.259	250.00	2.20	0.38
WAVE	20/11/2022 18:44	0.10	3.20	94	10.059	0.26	252.00	2.26	0.44
WAVE	20/11/2022 18:54	0.13	3.40	106	10.105	0.266	253.00	2.31	0.49
WAVE	20/11/2022 19:04	0.04	16.00	318	10.154	0.286	257.00	2.35	0.53
WAVE	20/11/2022 19:14	0.09	3.20	224	10.209	0.288	255.00	2.41	0.59
WAVE	20/11/2022 19:24	0.10	2.90	316	10.263	0.296	253.00	2.46	0.64
WAVE	20/11/2022 19:34	0.06	9.10	310	10.317	0.278	251.00	2.52	0.70
WAVE	20/11/2022 19:44	0.09	12.80	254	10.375	0.263	253.00	2.58	0.76
WAVE	20/11/2022 19:54	0.10	9.10	254	10.419	0.194	252.00	2.62	0.80
WAVE	20/11/2022 20:04	0.07	21.30	98	10.471	0.193	255.00	2.67	0.85
WAVE	20/11/2022 20:14	0.06	9.10	254	10.51	0.191	254.00	2.71	0.89
WAVE	20/11/2022 20:24	0.13	2.10	230	10.54	0.158	256.00	2.74	0.92
WAVE	20/11/2022 20:34	0.04	9.10	254	10.57	0.164	265.00	2.77	0.95
WAVE	20/11/2022 20:44	0.05	16.00	266	10.591	0.171	264.00	2.79	0.97
WAVE	20/11/2022 20:54	0.04	10.70	28	10.607	0.112	280.00	2.81	0.99
WAVE	20/11/2022 21:04	0.04	5.30	346	10.621	0.042	255.00	2.82	1.00

Name	Date Time	Significant Height(m)	Peak Time(sec)	Peak Direction (degree)	ADCP Depth(m)	Current Speed(m/s)	Current Direction (degree)	water level reference to CD	water level reference to 1.82 SHD
WAVE	20/11/2022 21:14	0.03	21.30	290	10.626	0.016	287.00	2.83	1.01
WAVE	20/11/2022 21:24	0.09	2.70	306	10.634	0.025	32.00	2.83	1.01
WAVE	20/11/2022 21:34	0.03	16.00	218	10.625	0.063	58.00	2.83	1.01
WAVE	20/11/2022 21:44	0.03	21.30	274	10.615	0.114	63.00	2.82	1.00
WAVE	20/11/2022 21:54	0.07	21.30	294	10.604	0.14	76.00	2.80	0.98
WAVE	20/11/2022 22:04	0.09	2.90	28	10.582	0.165	75.00	2.78	0.96
WAVE	20/11/2022 22:14	0.03	10.70	150	10.553	0.171	76.00	2.75	0.93
WAVE	20/11/2022 22:24	0.06	3.80	138	10.529	0.159	71.00	2.73	0.91
WAVE	20/11/2022 22:34	0.07	9.10	28	10.494	0.161	64.00	2.69	0.87
WAVE	20/11/2022 22:44	0.03	10.70	28	10.452	0.184	67.00	2.65	0.83
WAVE	20/11/2022 22:54	0.03	9.10	358	10.413	0.212	63.00	2.61	0.79
WAVE	20/11/2022 23:04	0.07	12.80	114	10.362	0.215	60.00	2.56	0.74
WAVE	20/11/2022 23:14	0.19	2.20	114	10.312	0.209	60.00	2.51	0.69
WAVE	20/11/2022 23:24	0.04	8.00	114	10.253	0.233	64.00	2.45	0.63
WAVE	20/11/2022 23:34	0.06	9.10	28	10.19	0.258	58.00	2.39	0.57
WAVE	20/11/2022 23:44	0.07	3.40	118	10.119	0.277	59.00	2.32	0.50
WAVE	20/11/2022 23:54	0.07	4.60	310	10.048	0.286	62.00	2.25	0.43
WAVE	21/11/2022 00:04	0.21	2.40	28	9.973	0.318	63.00	2.17	0.35
WAVE	21/11/2022 00:24	0.04	9.10	282	9.84	0.39	63.00	2.04	0.22
WAVE	21/11/2022 00:34	0.15	2.10	2	9.767	0.363	68.00	1.97	0.15
WAVE	21/11/2022 00:44	0.07	2.90	138	9.694	0.372	62.00	1.89	0.07
WAVE	21/11/2022 00:54	0.03	9.10	2	9.627	0.438	57.00	1.83	0.01
WAVE	21/11/2022 01:04	0.04	10.70	82	9.556	0.405	58.00	1.76	-0.06
WAVE	21/11/2022 01:14	0.11	2.50	230	9.484	0.38	61.00	1.68	-0.14
WAVE	21/11/2022 01:24	0.09	2.40	30	9.424	0.351	53.00	1.62	-0.20
WAVE	21/11/2022 01:34	0.02	16.00	6	9.366	0.375	53.00	1.57	-0.25
WAVE	21/11/2022 01:44	0.19	2.20	30	9.313	0.341	50.00	1.51	-0.31
WAVE	21/11/2022 01:54	0.15	2.30	306	9.243	0.291	55.00	1.44	-0.38
WAVE	21/11/2022 02:04	0.03	9.10	28	9.217	0.263	45.00	1.42	-0.40
WAVE	21/11/2022 02:14	0.05	16.00	238	9.196	0.199	52.00	1.40	-0.42
WAVE	21/11/2022 02:24	0.07	10.70	94	9.169	0.195	45.00	1.37	-0.45
WAVE	21/11/2022 02:34	0.10	8.00	350	9.153	0.14	44.00	1.35	-0.47
WAVE	21/11/2022 02:44	0.02	9.10	2	9.148	0.143	48.00	1.35	-0.47
WAVE	21/11/2022 02:54	0.04	4.60	28	9.153	0.076	55.00	1.35	-0.47
WAVE	21/11/2022 03:04	0.07	4.30	30	9.16	0.027	96.00	1.36	-0.46
WAVE	21/11/2022 03:14	0.04	21.30	218	9.192	0.016	226.00	1.39	-0.43
WAVE	21/11/2022 03:24	0.04	12.80	206	9.195	0.058	229.00	1.40	-0.43
WAVE	21/11/2022 03:34	0.05	21.30	250	9.207	0.089	219.00	1.41	-0.41
WAVE	21/11/2022 03:44	0.16	2.20	28	9.233	0.123	231.00	1.43	-0.39
WAVE	21/11/2022 03:54	0.04	5.30	170	9.258	0.156	239.00	1.46	-0.36
WAVE	21/11/2022 04:04	0.07	9.10	198	9.29	0.171	245.00	1.49	-0.33
WAVE	21/11/2022 04:14	0.10	10.70	290	9.323	0.197	240.00	1.52	-0.30
WAVE	21/11/2022 04:24	0.23	2.10	218	9.373	0.209	250.00	1.57	-0.25
WAVE	21/11/2022 04:34	0.07	9.10	162	9.412	0.172	250.00	1.61	-0.21
WAVE	21/11/2022 04:44	0.05	21.30	246	9.438	0.173	248.00	1.64	-0.18
WAVE	21/11/2022 04:54	0.07	21.30	54	9.446	0.176	254.00	1.65	-0.17
WAVE	21/11/2022 05:04	0.05	9.10	186	9.489	0.143	260.00	1.69	-0.13
WAVE	21/11/2022 05:14	0.07	9.10	22	9.537	0.144	257.00	1.74	-0.08
WAVE	21/11/2022 05:24	0.04	21.30	78	9.576	0.192	261.00	1.78	-0.04
WAVE	21/11/2022 05:34	0.05	4.90	146	9.611	0.175	268.00	1.81	-0.01
WAVE	21/11/2022 05:44	0.07	3.40	142	9.672	0.196	266.00	1.87	0.05
WAVE	21/11/2022 05:54	0.02	12.80	250	9.731	0.24	262.00	1.93	0.11
WAVE	21/11/2022 06:04	0.06	12.80	50	9.758	0.223	265.00	1.96	0.14
WAVE	21/11/2022 06:14	0.06	4.00	28	9.826	0.247	262.00	2.03	0.21
WAVE	21/11/2022 06:24	0.05	5.30	94	9.873	0.255	261.00	2.07	0.25
WAVE	21/11/2022 06:34	0.04	16.00	24	9.923	0.275	263.00	2.12	0.30
WAVE	21/11/2022 06:44	0.03	9.10	338	10.021	0.308	253.00	2.22	0.40
WAVE	21/11/2022 06:54	0.10	2.70	296	10.084	0.249	262.00	2.28	0.46
WAVE	21/11/2022 07:04	0.11	2.90	110	10.168	0.267	251.00	2.37	0.55
WAVE	21/11/2022 07:14	0.04	12.80	58	10.225	0.261	252.00	2.43	0.61
WAVE	21/11/2022 07:24	0.07	4.30	28	10.316	0.296	251.00	2.52	0.70
WAVE	21/11/2022 07:34	0.07	4.30	28	10.39	0.239	247.00	2.59	0.77
WAVE	21/11/2022 07:44	0.15	2.10	26	10.454	0.211	248.00	2.65	0.83
WAVE	21/11/2022 07:54	0.10	3.20	246	10.525	0.285	251.00	2.73	0.91

Name	Date Time	Significant Height(m)	Peak Time(sec)	Peak Direction (degree)	ADCP Depth(m)	Current Speed(m/s)	Current Direction (degree)	water level reference to CD	water level reference to 1.82 SHD
WAVE	21/11/2022 08:14	0.06	16.00	28	10.654	0.287	255.00	2.85	1.03
WAVE	21/11/2022 08:24	0.22	2.80	105	10.69	0.261	247.00	2.89	1.07
WAVE	21/11/2022 08:34	0.07	3.00	134	10.725	0.211	250.00	2.93	1.11
WAVE	21/11/2022 08:44	0.08	2.90	142	10.75	0.207	258.00	2.95	1.13
WAVE	21/11/2022 08:54	0.08	2.90	238	10.767	0.173	247.00	2.97	1.15
WAVE	21/11/2022 09:04	0.07	3.80	182	10.799	0.18	236.00	3.00	1.18
WAVE	21/11/2022 09:14	0.10	2.90	254	10.805	0.135	238.00	3.01	1.19
WAVE	21/11/2022 09:24	0.04	21.30	146	10.819	0.125	246.00	3.02	1.20
WAVE	21/11/2022 09:34	0.06	3.60	102	10.806	0.061	233.00	3.01	1.19
WAVE	21/11/2022 09:44	0.07	9.10	18	10.782	0.047	212.00	2.98	1.16
WAVE	21/11/2022 09:54	0.12	3.60	114	10.778	0.07	135.00	2.98	1.16
WAVE	21/11/2022 10:04	0.05	9.10	282	10.748	0.136	90.00	2.95	1.13
WAVE	21/11/2022 10:14	0.07	3.40	82	10.715	0.152	82.00	2.92	1.10
WAVE	21/11/2022 10:24	0.07	3.00	134	10.659	0.208	69.00	2.86	1.04
WAVE	21/11/2022 10:34	0.08	2.70	18	10.631	0.233	73.00	2.83	1.01
WAVE	21/11/2022 10:44	0.07	4.00	66	10.585	0.287	75.00	2.79	0.97
WAVE	21/11/2022 10:54	0.05	21.30	282	10.532	0.328	59.00	2.73	0.91
WAVE	21/11/2022 11:14	0.07	2.70	306	10.394	0.356	61.00	2.59	0.77
WAVE	21/11/2022 11:24	0.12	3.60	114	10.323	0.351	57.00	2.52	0.70
WAVE	21/11/2022 11:34	0.06	9.10	238	10.241	0.364	58.00	2.44	0.62
WAVE	21/11/2022 11:44	0.03	9.10	222	10.168	0.321	58.00	2.37	0.55
WAVE	21/11/2022 11:54	0.07	16.00	82	10.068	0.37	56.00	2.27	0.45
WAVE	21/11/2022 12:04	0.10	3.20	88	9.991	0.419	63.00	2.19	0.37
WAVE	21/11/2022 12:14	0.03	9.10	322	9.922	0.393	58.00	2.12	0.30
WAVE	21/11/2022 12:24	0.03	10.70	230	9.844	0.351	61.00	2.04	0.22
WAVE	21/11/2022 12:34	0.05	6.40	28	9.754	0.338	54.00	1.95	0.13
WAVE	21/11/2022 12:44	0.09	3.00	78	9.688	0.274	59.00	1.89	0.07
WAVE	21/11/2022 12:54	0.18	2.80	276	9.613	0.214	53.00	1.81	-0.01
WAVE	21/11/2022 13:14	0.07	3.00	70	9.465	0.197	60.00	1.67	-0.16
WAVE	21/11/2022 13:24	0.11	2.70	262	9.407	0.239	55.00	1.61	-0.21
WAVE	21/11/2022 13:34	0.07	3.00	126	9.322	0.243	61.00	1.52	-0.30
WAVE	21/11/2022 13:54	0.02	16.00	230	9.195	0.278	47.00	1.40	-0.43
WAVE	21/11/2022 14:04	0.10	2.80	110	9.131	0.26	42.00	1.33	-0.49
WAVE	21/11/2022 14:14	0.18	2.30	14	9.074	0.251	37.00	1.27	-0.55
WAVE	21/11/2022 14:24	0.23	2.10	210	9.035	0.238	33.00	1.24	-0.59
WAVE	21/11/2022 14:34	0.03	16.00	28	8.995	0.226	35.00	1.20	-0.63
WAVE	21/11/2022 14:44	0.05	10.70	28	8.975	0.186	37.00	1.18	-0.65
WAVE	21/11/2022 14:54	0.13	3.00	107	8.959	0.188	35.00	1.16	-0.66
WAVE	21/11/2022 15:04	0.21	3.40	298	8.94	0.149	27.00	1.14	-0.68
WAVE	21/11/2022 15:14	0.09	3.00	82	8.945	0.094	25.00	1.15	-0.68
WAVE	21/11/2022 15:24	0.07	16.00	294	8.95	0.069	7.00	1.15	-0.67
WAVE	21/11/2022 15:34	0.06	12.80	310	8.943	0.054	335.00	1.14	-0.68
WAVE	21/11/2022 15:44	0.13	3.20	306	8.936	0.028	295.00	1.14	-0.68
WAVE	21/11/2022 15:54	0.05	8.00	310	8.964	0.058	276.00	1.16	-0.66
WAVE	21/11/2022 16:04	0.08	3.80	90	8.989	0.069	254.00	1.19	-0.63
WAVE	21/11/2022 16:14	0.25	2.80	298	9.023	0.082	245.00	1.22	-0.60
WAVE	21/11/2022 16:24	0.03	9.10	238	9.032	0.146	244.00	1.23	-0.59
WAVE	21/11/2022 16:34	0.07	3.20	118	9.089	0.155	240.00	1.29	-0.53
WAVE	21/11/2022 16:44	0.13	2.90	270	9.133	0.169	239.00	1.33	-0.49
WAVE	21/11/2022 16:54	0.10	3.00	278	9.174	0.217	243.00	1.37	-0.45
WAVE	21/11/2022 17:04	0.08	10.70	204	9.22	0.255	258.00	1.42	-0.40
WAVE	21/11/2022 17:14	0.09	2.90	222	9.247	0.224	260.00	1.45	-0.37
WAVE	21/11/2022 17:24	0.06	3.40	242	9.308	0.229	268.00	1.51	-0.31
WAVE	21/11/2022 17:34	0.04	10.70	290	9.352	0.239	269.00	1.55	-0.27
WAVE	21/11/2022 17:44	0.13	2.10	270	9.408	0.216	261.00	1.61	-0.21
WAVE	21/11/2022 17:54	0.08	2.70	298	9.46	0.225	270.00	1.66	-0.16
WAVE	21/11/2022 18:04	0.03	16.00	238	9.512	0.249	265.00	1.71	-0.11
WAVE	21/11/2022 18:14	0.07	12.80	28	9.571	0.23	270.00	1.77	-0.05
WAVE	21/11/2022 18:24	0.07	3.20	294	9.625	0.249	263.00	1.83	0.01
WAVE	21/11/2022 18:34	0.08	4.00	106	9.678	0.223	261.00	1.88	0.06
WAVE	21/11/2022 18:44	0.02	16.00	266	9.73	0.271	259.00	1.93	0.11
WAVE	21/11/2022 18:54	0.02	16.00	98	9.786	0.269	263.00	1.99	0.17
WAVE	21/11/2022 19:04	0.07	4.00	118	9.856	0.288	261.00	2.06	0.24
WAVE	21/11/2022 19:14	0.07	4.00	122	9.911	0.29	261.00	2.11	0.29

Name	Date Time	Significant Height(m)	Peak Time(sec)	Peak Direction (degree)	ADCP Depth(m)	Current Speed(m/s)	Current Direction (degree)	water level reference to CD	water level reference to 1.82 SHD
WAVE	21/11/2022 19:24	0.07	12.80	28	9.963	0.298	264.00	2.16	0.34
WAVE	21/11/2022 19:34	0.07	3.40	102	10.038	0.234	275.00	2.24	0.42
WAVE	21/11/2022 19:44	0.09	9.10	122	10.102	0.292	260.00	2.30	0.48
WAVE	21/11/2022 19:54	0.09	2.60	288	10.176	0.256	255.00	2.38	0.56
WAVE	21/11/2022 20:04	0.07	3.20	30	10.237	0.274	259.00	2.44	0.62
WAVE	21/11/2022 20:14	0.05	12.80	182	10.319	0.23	262.00	2.52	0.70
WAVE	21/11/2022 20:24	0.11	2.90	139	10.384	0.237	263.00	2.58	0.76
WAVE	21/11/2022 20:34	0.07	9.10	28	10.45	0.209	254.00	2.65	0.83
WAVE	21/11/2022 20:44	0.04	7.10	326	10.518	0.223	260.00	2.72	0.90
WAVE	21/11/2022 20:54	0.05	4.00	122	10.552	0.25	266.00	2.75	0.93
WAVE	21/11/2022 21:04	0.45	3.20	91	10.597	0.246	266.00	2.80	0.98
WAVE	21/11/2022 21:14	0.20	2.10	338	10.644	0.24	271.00	2.84	1.02
WAVE	21/11/2022 21:24	0.04	3.80	326	10.668	0.156	281.00	2.87	1.05
WAVE	21/11/2022 21:34	0.06	21.30	266	10.699	0.136	273.00	2.90	1.08
WAVE	21/11/2022 21:44	0.03	12.80	342	10.725	0.068	286.00	2.93	1.11
WAVE	21/11/2022 21:54	0.05	3.80	58	10.736	0.058	267.00	2.94	1.12
WAVE	21/11/2022 22:04	0.06	21.30	282	10.744	0.081	273.00	2.94	1.12
WAVE	21/11/2022 22:14	0.03	12.80	26	10.741	0.039	262.00	2.94	1.12
WAVE	21/11/2022 22:24	0.05	10.70	54	10.725	0.023	202.00	2.93	1.11
WAVE	21/11/2022 22:34	0.08	9.10	10	10.698	0.081	72.00	2.90	1.08
WAVE	21/11/2022 22:44	0.05	5.30	74	10.684	0.134	57.00	2.88	1.06
WAVE	21/11/2022 22:54	0.02	9.10	6	10.664	0.168	82.00	2.86	1.04
WAVE	21/11/2022 23:04	0.07	2.80	122	10.633	0.177	81.00	2.83	1.01
WAVE	21/11/2022 23:14	0.05	21.30	310	10.59	0.201	80.00	2.79	0.97
WAVE	21/11/2022 23:24	0.28	1.90	210	10.532	0.231	77.00	2.73	0.91
WAVE	21/11/2022 23:34	0.09	2.80	118	10.484	0.243	78.00	2.68	0.86
WAVE	21/11/2022 23:44	0.11	2.20	338	10.431	0.289	74.00	2.63	0.81
WAVE	21/11/2022 23:54	0.04	12.80	26	10.367	0.318	69.00	2.57	0.75
WAVE	22/11/2022 00:04	0.03	9.10	306	10.314	0.294	64.00	2.51	0.69
WAVE	22/11/2022 00:14	0.05	9.10	110	10.235	0.301	63.00	2.44	0.62
WAVE	22/11/2022 00:24	0.09	21.30	222	10.159	0.283	64.00	2.36	0.54
WAVE	22/11/2022 00:34	0.04	12.80	28	10.071	0.267	61.00	2.27	0.45
WAVE	22/11/2022 00:44	0.07	4.00	78	9.985	0.334	68.00	2.19	0.37
WAVE	22/11/2022 00:54	0.07	9.10	246	9.902	0.36	65.00	2.10	0.28
WAVE	22/11/2022 01:04	0.04	10.70	162	9.818	0.319	75.00	2.02	0.20
WAVE	22/11/2022 01:14	0.07	10.70	174	9.74	0.312	66.00	1.94	0.12
WAVE	22/11/2022 01:24	0.08	2.50	214	9.664	0.28	65.00	1.86	0.04
WAVE	22/11/2022 01:34	0.06	5.80	210	9.598	0.208	71.00	1.80	-0.02
WAVE	22/11/2022 01:44	0.06	3.80	30	9.527	0.195	77.00	1.73	-0.09
WAVE	22/11/2022 01:54	0.07	3.40	122	9.441	0.246	77.00	1.64	-0.18
WAVE	22/11/2022 02:04	0.09	2.30	212	9.362	0.16	70.00	1.56	-0.26
WAVE	22/11/2022 02:14	0.06	4.30	262	9.29	0.161	66.00	1.49	-0.33
WAVE	22/11/2022 02:24	0.06	5.30	298	9.221	0.212	57.00	1.42	-0.40
WAVE	22/11/2022 02:34	0.08	3.80	28	9.17	0.116	62.00	1.37	-0.45
WAVE	22/11/2022 02:44	0.03	9.10	22	9.128	0.194	44.00	1.33	-0.49
WAVE	22/11/2022 02:54	0.04	7.10	330	9.088	0.243	40.00	1.29	-0.53
WAVE	22/11/2022 03:04	0.03	9.10	102	9.048	0.197	35.00	1.25	-0.57
WAVE	22/11/2022 03:14	0.09	3.80	110	9.03	0.157	20.00	1.23	-0.59
WAVE	22/11/2022 03:24	0.03	10.70	2	9.007	0.139	16.00	1.21	-0.61
WAVE	22/11/2022 03:34	0.03	10.70	130	9.001	0.087	23.00	1.20	-0.62
WAVE	22/11/2022 03:44	0.11	10.70	322	9.006	0.074	35.00	1.21	-0.61
WAVE	22/11/2022 03:54	0.07	6.40	250	9.007	0.016	57.00	1.21	-0.61
WAVE	22/11/2022 04:04	0.04	7.10	318	9.026	0.026	348.00	1.23	-0.59
WAVE	22/11/2022 04:14	0.10	3.20	342	9.049	0.03	315.00	1.25	-0.57
WAVE	22/11/2022 04:24	0.05	9.10	322	9.075	0.045	282.00	1.28	-0.55
WAVE	22/11/2022 04:34	0.06	4.60	30	9.106	0.078	266.00	1.31	-0.51
WAVE	22/11/2022 04:44	0.09	2.50	36	9.146	0.098	254.00	1.35	-0.47
WAVE	22/11/2022 04:54	0.17	2.30	346	9.185	0.125	248.00	1.39	-0.43
WAVE	22/11/2022 05:04	0.07	4.60	28	9.228	0.162	249.00	1.43	-0.39
WAVE	22/11/2022 05:14	0.03	16.00	230	9.277	0.204	243.00	1.48	-0.34
WAVE	22/11/2022 05:24	0.09	3.60	270	9.33	0.239	247.00	1.53	-0.29
WAVE	22/11/2022 05:34	0.04	16.00	118	9.383	0.247	251.00	1.58	-0.24
WAVE	22/11/2022 05:44	0.06	5.30	302	9.439	0.295	259.00	1.64	-0.18
WAVE	22/11/2022 05:54	0.07	3.00	28	9.51	0.297	258.00	1.71	-0.11

Name	Date Time	Significant Height(m)	Peak Time(sec)	Peak Direction (degree)	ADCP Depth(m)	Current Speed(m/s)	Current Direction (degree)	water level reference to CD	water level reference to 1.82 SHD
WAVE	22/11/2022 06:04	0.02	10.70	246	9.57	0.241	259.00	1.77	-0.05
WAVE	22/11/2022 06:14	0.03	8.00	118	9.626	0.217	259.00	1.83	0.01
WAVE	22/11/2022 06:24	0.03	9.10	110	9.685	0.217	251.00	1.89	0.07
WAVE	22/11/2022 06:34	0.11	2.30	302	9.751	0.236	252.00	1.95	0.13
WAVE	22/11/2022 06:44	0.04	12.80	134	9.813	0.267	252.00	2.01	0.19
WAVE	22/11/2022 06:54	0.07	2.80	108	9.896	0.33	257.00	2.10	0.28
WAVE	22/11/2022 07:04	0.10	2.90	274	9.969	0.322	262.00	2.17	0.35
WAVE	22/11/2022 07:14	0.16	2.10	358	10.04	0.338	265.00	2.24	0.42
WAVE	22/11/2022 07:24	0.04	10.70	28	10.132	0.338	256.00	2.33	0.51
WAVE	22/11/2022 07:34	0.01	16.00	334	10.216	0.34	256.00	2.42	0.60
WAVE	22/11/2022 07:44	0.03	12.80	102	10.294	0.324	267.00	2.49	0.67
WAVE	22/11/2022 07:54	0.10	10.70	262	10.39	0.315	264.00	2.59	0.77
WAVE	22/11/2022 08:04	0.07	3.00	262	10.452	0.308	266.00	2.65	0.83
WAVE	22/11/2022 08:24	0.14	2.70	124	10.615	0.285	259.00	2.82	1.00
WAVE	22/11/2022 08:34	0.07	3.80	342	10.683	0.316	250.00	2.88	1.06
WAVE	22/11/2022 08:44	0.14	3.40	100	10.74	0.33	262.00	2.94	1.12
WAVE	22/11/2022 08:54	0.09	3.20	210	10.787	0.189	252.00	2.99	1.17
WAVE	22/11/2022 09:04	0.06	8.00	28	10.841	0.27	259.00	3.04	1.22
WAVE	22/11/2022 09:14	0.11	3.20	87	10.845	0.177	244.00	3.05	1.23
WAVE	22/11/2022 09:24	0.17	2.10	134	10.9	0.177	248.00	3.10	1.28
WAVE	22/11/2022 09:34	0.05	4.60	202	10.916	0.023	265.00	3.12	1.30
WAVE	22/11/2022 09:44	0.06	3.20	226	10.931	0.063	216.00	3.13	1.31
WAVE	22/11/2022 09:54	0.07	3.60	96	10.933	0.043	132.00	3.13	1.31
WAVE	22/11/2022 10:04	0.19	2.50	230	10.92	0.068	99.00	3.12	1.30
WAVE	22/11/2022 10:14	0.04	9.10	202	10.897	0.089	75.00	3.10	1.28
WAVE	22/11/2022 10:24	0.12	3.00	118	10.876	0.123	79.00	3.08	1.26
WAVE	22/11/2022 10:34	0.04	9.10	286	10.841	0.163	66.00	3.04	1.22
WAVE	22/11/2022 10:44	0.20	2.90	89	10.801	0.206	70.00	3.00	1.18
WAVE	22/11/2022 10:54	0.13	3.20	110	10.754	0.301	74.00	2.95	1.13
WAVE	22/11/2022 11:04	0.06	4.30	138	10.699	0.289	77.00	2.90	1.08
WAVE	22/11/2022 11:14	0.07	3.60	178	10.641	0.339	72.00	2.84	1.02
WAVE	22/11/2022 11:24	0.06	16.00	206	10.572	0.373	68.00	2.77	0.95
WAVE	22/11/2022 11:34	0.04	9.10	346	10.505	0.412	64.00	2.71	0.89
WAVE	22/11/2022 11:44	0.29	2.90	293	10.417	0.385	60.00	2.62	0.80
WAVE	22/11/2022 11:54	0.06	4.00	194	10.334	0.344	65.00	2.53	0.71
WAVE	22/11/2022 12:04	0.11	3.40	82	10.248	0.287	73.00	2.45	0.63
WAVE	22/11/2022 12:14	0.02	12.80	342	10.145	0.254	59.00	2.35	0.53
WAVE	22/11/2022 12:24	0.08	4.30	102	10.05	0.231	77.00	2.25	0.43
WAVE	22/11/2022 12:34	0.08	2.70	194	9.951	0.297	82.00	2.15	0.33
WAVE	22/11/2022 12:44	0.14	3.00	299	9.859	0.265	82.00	2.06	0.24
WAVE	22/11/2022 12:54	0.09	2.80	106	9.784	0.293	83.00	1.98	0.16
WAVE	22/11/2022 13:04	0.04	10.70	2	9.678	0.323	84.00	1.88	0.06
WAVE	22/11/2022 13:14	0.05	4.30	106	9.589	0.343	80.00	1.79	-0.03
WAVE	22/11/2022 13:24	0.03	9.10	166	9.487	0.339	75.00	1.69	-0.13
WAVE	22/11/2022 13:34	0.09	9.10	234	9.394	0.318	77.00	1.59	-0.23
WAVE	22/11/2022 13:54	0.03	9.10	114	9.213	0.297	78.00	1.41	-0.41
WAVE	22/11/2022 14:04	0.08	3.40	82	9.12	0.29	74.00	1.32	-0.50
WAVE	22/11/2022 14:14	0.13	4.00	86	9.043	0.26	73.00	1.24	-0.58
WAVE	22/11/2022 14:24	0.09	3.20	86	8.967	0.187	68.00	1.17	-0.65
WAVE	22/11/2022 14:34	0.09	4.60	150	8.891	0.128	59.00	1.09	-0.73
WAVE	22/11/2022 14:44	0.12	2.90	98	8.838	0.086	49.00	1.04	-0.78
WAVE	22/11/2022 14:54	0.05	3.80	274	8.784	0.066	38.00	0.98	-0.84
WAVE	22/11/2022 15:04	0.14	2.70	184	8.741	0.028	338.00	0.94	-0.88
WAVE	22/11/2022 15:14	0.10	2.80	270	8.705	0.065	346.00	0.91	-0.92
WAVE	22/11/2022 15:24	0.11	3.00	86	8.678	0.087	3.00	0.88	-0.94
WAVE	22/11/2022 15:34	0.15	2.80	302	8.654	0.11	4.00	0.85	-0.97
WAVE	22/11/2022 15:44	0.09	4.00	126	8.645	0.107	354.00	0.85	-0.98
WAVE	22/11/2022 15:54	0.14	2.20	130	8.653	0.112	341.00	0.85	-0.97
WAVE	22/11/2022 16:04	0.08	2.90	62	8.656	0.07	323.00	0.86	-0.96
WAVE	22/11/2022 16:14	0.07	3.80	82	8.667	0.083	288.00	0.87	-0.95
WAVE	22/11/2022 16:24	0.12	2.80	106	8.691	0.084	279.00	0.89	-0.93
WAVE	22/11/2022 16:34	0.13	2.60	114	8.721	0.104	260.00	0.92	-0.90
WAVE	22/11/2022 16:44	0.16	2.90	294	8.738	0.095	279.00	0.94	-0.88
WAVE	22/11/2022 16:54	0.10	2.90	290	8.782	0.118	245.00	0.98	-0.84

Name	Date Time	Significant Height(m)	Peak Time(sec)	Peak Direction (degree)	ADCP Depth(m)	Current Speed(m/s)	Current Direction (degree)	water level reference to CD	water level reference to 1.82 SHD
WAVE	22/11/2022 17:04	0.13	2.80	270	8.821	0.125	254.00	1.02	-0.80
WAVE	22/11/2022 17:14	0.07	6.40	94	8.862	0.149	255.00	1.06	-0.76
WAVE	22/11/2022 17:24	0.13	3.20	282	8.915	0.193	244.00	1.12	-0.71
WAVE	22/11/2022 17:34	0.06	7.10	346	8.966	0.185	254.00	1.17	-0.65
WAVE	22/11/2022 17:44	0.08	2.80	242	9.024	0.232	259.00	1.22	-0.60
WAVE	22/11/2022 17:54	0.03	12.80	66	9.094	0.282	256.00	1.29	-0.53
WAVE	22/11/2022 18:04	0.09	3.40	314	9.167	0.292	250.00	1.37	-0.45
WAVE	22/11/2022 18:14	0.07	3.80	90	9.24	0.335	257.00	1.44	-0.38
WAVE	22/11/2022 18:24	0.10	4.00	238	9.318	0.323	249.00	1.52	-0.30
WAVE	22/11/2022 18:34	0.06	4.00	28	9.394	0.329	262.00	1.59	-0.23
WAVE	22/11/2022 18:44	0.04	9.10	202	9.47	0.321	254.00	1.67	-0.15
WAVE	22/11/2022 18:54	0.08	2.90	94	9.552	0.395	263.00	1.75	-0.07
WAVE	22/11/2022 19:04	0.15	2.80	120	9.619	0.412	260.00	1.82	0.00
WAVE	22/11/2022 19:14	0.19	3.60	280	9.691	0.404	265.00	1.89	0.07
WAVE	22/11/2022 19:24	0.10	2.80	194	9.775	0.339	260.00	1.98	0.16
WAVE	22/11/2022 19:34	0.16	2.10	254	9.851	0.324	258.00	2.05	0.23
WAVE	22/11/2022 19:44	0.10	2.50	318	9.933	0.244	260.00	2.13	0.31
WAVE	22/11/2022 19:54	0.06	21.30	150	10.012	0.298	258.00	2.21	0.39
WAVE	22/11/2022 20:04	0.09	3.80	114	10.1	0.282	253.00	2.30	0.48
WAVE	22/11/2022 20:14	0.10	3.40	282	10.174	0.285	258.00	2.37	0.55
WAVE	22/11/2022 20:24	0.07	4.30	214	10.257	0.219	258.00	2.46	0.64
WAVE	22/11/2022 20:34	0.18	2.20	358	10.34	0.298	268.00	2.54	0.72
WAVE	22/11/2022 20:44	0.13	2.10	240	10.422	0.302	267.00	2.62	0.80
WAVE	22/11/2022 20:54	0.07	9.10	270	10.5	0.329	258.00	2.70	0.88
WAVE	22/11/2022 21:04	0.08	2.70	26	10.578	0.316	258.00	2.78	0.96
WAVE	22/11/2022 21:14	0.05	3.80	314	10.653	0.277	259.00	2.85	1.03
WAVE	22/11/2022 21:24	0.07	3.40	234	10.699	0.252	248.00	2.90	1.08
WAVE	22/11/2022 21:34	0.04	9.10	246	10.758	0.258	249.00	2.96	1.14
WAVE	22/11/2022 21:44	0.06	9.10	14	10.807	0.257	251.00	3.01	1.19
WAVE	22/11/2022 21:54	0.12	2.40	162	10.852	0.259	247.00	3.05	1.23
WAVE	22/11/2022 22:04	0.04	16.00	278	10.905	0.232	251.00	3.11	1.29
WAVE	22/11/2022 22:14	0.12	2.90	150	10.924	0.176	258.00	3.12	1.30
WAVE	22/11/2022 22:24	0.04	12.80	28	10.956	0.13	257.00	3.16	1.34
WAVE	22/11/2022 22:34	0.04	12.80	28	10.977	0.118	258.00	3.18	1.36
WAVE	22/11/2022 22:44	0.05	10.70	318	10.985	0.076	267.00	3.19	1.37
WAVE	22/11/2022 22:54	0.04	8.00	28	10.996	0.089	11.00	3.20	1.38
WAVE	22/11/2022 23:04	0.06	4.30	130	10.99	0.087	82.00	3.19	1.37
WAVE	22/11/2022 23:14	0.03	21.30	266	10.966	0.143	58.00	3.17	1.35
WAVE	22/11/2022 23:24	0.02	9.10	222	10.949	0.174	56.00	3.15	1.33
WAVE	22/11/2022 23:34	0.04	5.80	198	10.93	0.205	59.00	3.13	1.31
WAVE	22/11/2022 23:44	0.03	12.80	262	10.89	0.243	75.00	3.09	1.27
WAVE	22/11/2022 23:54	0.07	3.80	102	10.843	0.245	55.00	3.04	1.22
WAVE	23/11/2022 00:04	0.02	10.70	114	10.805	0.286	67.00	3.01	1.19
WAVE	23/11/2022 00:14	0.03	21.30	28	10.747	0.345	65.00	2.95	1.13
WAVE	23/11/2022 00:24	0.07	16.00	158	10.696	0.375	65.00	2.90	1.08
WAVE	23/11/2022 00:34	0.07	10.70	226	10.633	0.344	68.00	2.83	1.01
WAVE	23/11/2022 00:44	0.08	3.60	326	10.564	0.323	67.00	2.76	0.94
WAVE	23/11/2022 00:54	0.06	9.10	270	10.479	0.32	75.00	2.68	0.86
WAVE	23/11/2022 01:04	0.07	21.30	298	10.399	0.295	82.00	2.60	0.78
WAVE	23/11/2022 01:14	0.09	2.50	326	10.31	0.283	83.00	2.51	0.69
WAVE	23/11/2022 01:24	0.06	4.60	306	10.217	0.347	77.00	2.42	0.60
WAVE	23/11/2022 01:34	0.04	10.70	28	10.124	0.345	81.00	2.32	0.50
WAVE	23/11/2022 01:44	0.03	16.00	242	10.038	0.345	77.00	2.24	0.42
WAVE	23/11/2022 01:54	0.09	2.40	226	9.937	0.359	80.00	2.14	0.32
WAVE	23/11/2022 02:04	0.06	5.30	78	9.852	0.365	78.00	2.05	0.23
WAVE	23/11/2022 02:14	0.03	9.10	70	9.667	0.342	79.00	1.87	0.05
WAVE	23/11/2022 02:24	0.03	10.70	94	9.584	0.307	80.00	1.78	-0.04
WAVE	23/11/2022 02:34	0.07	10.70	150	9.509	0.282	78.00	1.71	-0.11
WAVE	23/11/2022 02:44	0.06	5.30	306	9.417	0.236	78.00	1.62	-0.20
WAVE	23/11/2022 02:54	0.08	3.60	138	9.341	0.201	82.00	1.54	-0.28
WAVE	23/11/2022 03:04	0.08	3.00	298	9.285	0.209	84.00	1.49	-0.34
WAVE	23/11/2022 03:14	0.04	10.70	62	9.207	0.135	74.00	1.41	-0.41
WAVE	23/11/2022 03:24	0.03	21.30	250	9.171	0.077	92.00	1.37	-0.45
WAVE	23/11/2022 03:34	0.07	10.70	182	9.122	0.044	102.00	1.32	-0.50

Name	Date Time	Significant Height(m)	Peak Time(sec)	Peak Direction (degree)	ADCP Depth(m)	Current Speed(m/s)	Current Direction (degree)	water level reference to CD	water level reference to 1.82 SHD
WAVE	23/11/2022 03:54	0.04	5.80	114	9.101	0.034	293.00	1.30	-0.52
WAVE	23/11/2022 04:14	0.03	9.10	358	9.056	0.098	287.00	1.26	-0.56
WAVE	23/11/2022 04:24	0.05	4.00	110	9.058	0.139	280.00	1.26	-0.56
WAVE	23/11/2022 04:34	0.10	2.70	294	9.069	0.146	268.00	1.27	-0.55
WAVE	23/11/2022 04:44	0.02	16.00	28	9.097	0.145	273.00	1.30	-0.52
WAVE	23/11/2022 04:54	0.04	5.80	314	9.112	0.095	304.00	1.31	-0.51
WAVE	23/11/2022 05:04	0.07	3.80	210	9.157	0.173	252.00	1.36	-0.46
WAVE	23/11/2022 05:14	0.09	2.90	28	9.181	0.193	256.00	1.38	-0.44
WAVE	23/11/2022 05:24	0.13	2.60	326	9.227	0.179	257.00	1.43	-0.39
WAVE	23/11/2022 05:34	0.09	3.60	254	9.278	0.169	252.00	1.48	-0.34
WAVE	23/11/2022 05:44	0.03	9.10	28	9.33	0.181	252.00	1.53	-0.29
WAVE	23/11/2022 05:54	0.14	2.50	94	9.386	0.196	249.00	1.59	-0.23
WAVE	23/11/2022 06:04	0.04	12.80	274	9.441	0.138	262.00	1.64	-0.18
WAVE	23/11/2022 06:14	0.09	2.90	286	9.486	0.148	274.00	1.69	-0.13
WAVE	23/11/2022 06:24	0.08	3.00	254	9.54	0.158	258.00	1.74	-0.08
WAVE	23/11/2022 06:34	0.04	10.70	150	9.594	0.21	260.00	1.79	-0.03
WAVE	23/11/2022 06:44	0.14	2.20	10	9.659	0.221	262.00	1.86	0.04
WAVE	23/11/2022 06:54	0.06	8.00	122	9.719	0.208	257.00	1.92	0.10
WAVE	23/11/2022 07:04	0.06	5.80	28	9.785	0.219	268.00	1.99	0.17
WAVE	23/11/2022 07:14	0.11	2.80	118	9.861	0.174	254.00	2.06	0.24
WAVE	23/11/2022 07:24	0.03	21.30	14	9.943	0.171	249.00	2.14	0.32
WAVE	23/11/2022 07:34	0.08	2.90	246	10.023	0.191	261.00	2.22	0.40
WAVE	23/11/2022 07:44	0.08	4.00	326	10.121	0.255	252.00	2.32	0.50
WAVE	23/11/2022 07:54	0.03	10.70	218	10.213	0.313	251.00	2.41	0.59
WAVE	23/11/2022 08:04	0.11	2.50	102	10.294	0.439	261.00	2.49	0.67
WAVE	23/11/2022 08:14	0.05	21.30	222	10.404	0.399	258.00	2.60	0.78
WAVE	23/11/2022 08:24	0.12	2.40	26	10.493	0.411	258.00	2.69	0.87
WAVE	23/11/2022 08:34	0.08	12.80	242	10.582	0.404	255.00	2.78	0.96
WAVE	23/11/2022 08:44	0.14	2.60	108	10.657	0.425	258.00	2.86	1.04
WAVE	23/11/2022 08:54	0.08	6.40	28	10.727	0.363	255.00	2.93	1.11
WAVE	23/11/2022 09:04	0.10	9.10	290	10.786	0.329	253.00	2.99	1.17
WAVE	23/11/2022 09:14	0.06	5.30	326	10.858	0.311	255.00	3.06	1.24
WAVE	23/11/2022 09:24	0.16	2.80	120	10.922	0.248	255.00	3.12	1.30
WAVE	23/11/2022 09:34	0.08	3.00	126	10.964	0.208	258.00	3.16	1.34
WAVE	23/11/2022 09:44	0.07	21.30	238	10.998	0.191	254.00	3.20	1.38
WAVE	23/11/2022 09:54	0.27	2.80	97	11.025	0.125	257.00	3.23	1.41
WAVE	23/11/2022 10:04	0.03	9.10	338	11.046	0.073	303.00	3.25	1.43
WAVE	23/11/2022 10:14	0.08	2.70	210	11.044	0.05	29.00	3.24	1.42
WAVE	23/11/2022 10:24	0.09	3.20	22	11.031	0.083	113.00	3.23	1.41
WAVE	23/11/2022 10:34	0.16	3.00	100	10.996	0.177	77.00	3.20	1.38
WAVE	23/11/2022 10:44	0.04	4.00	218	10.968	0.181	52.00	3.17	1.35
WAVE	23/11/2022 10:54	0.13	2.70	302	10.927	0.185	80.00	3.13	1.31
WAVE	23/11/2022 11:04	0.02	9.10	114	10.89	0.234	84.00	3.09	1.27
WAVE	23/11/2022 11:14	0.06	4.00	122	10.84	0.269	55.00	3.04	1.22
WAVE	23/11/2022 11:24	0.06	4.60	154	10.787	0.358	62.00	2.99	1.17
WAVE	23/11/2022 11:34	0.07	3.60	46	10.722	0.387	65.00	2.92	1.10
WAVE	23/11/2022 11:44	0.13	2.40	232	10.649	0.453	72.00	2.85	1.03
WAVE	23/11/2022 11:54	0.12	3.00	114	10.581	0.428	74.00	2.78	0.96
WAVE	23/11/2022 12:04	0.06	3.60	130	10.492	0.407	67.00	2.69	0.87
WAVE	23/11/2022 12:14	0.10	4.00	94	10.41	0.39	67.00	2.61	0.79
WAVE	23/11/2022 12:24	0.08	3.20	122	10.309	0.324	79.00	2.51	0.69
WAVE	23/11/2022 12:34	0.07	5.30	226	10.212	0.336	73.00	2.41	0.59
WAVE	23/11/2022 12:44	0.11	3.00	110	10.106	0.316	78.00	2.31	0.49
WAVE	23/11/2022 12:54	0.06	12.80	306	10.005	0.345	76.00	2.21	0.39
WAVE	23/11/2022 13:04	0.19	2.80	284	9.893	0.367	79.00	2.09	0.27
WAVE	23/11/2022 13:14	0.05	21.30	270	9.797	0.382	80.00	2.00	0.18
WAVE	23/11/2022 13:24	0.09	4.60	126	9.688	0.385	79.00	1.89	0.07
WAVE	23/11/2022 13:34	0.05	9.10	242	9.583	0.379	79.00	1.78	-0.04
WAVE	23/11/2022 13:44	0.13	3.20	202	9.494	0.372	79.00	1.69	-0.13
WAVE	23/11/2022 13:54	0.06	3.80	126	9.399	0.348	83.00	1.60	-0.22
WAVE	23/11/2022 14:04	0.08	6.40	150	9.298	0.339	78.00	1.50	-0.32
WAVE	23/11/2022 14:14	0.03	9.10	28	9.191	0.314	76.00	1.39	-0.43
WAVE	23/11/2022 14:24	0.11	3.20	84	9.083	0.3	73.00	1.28	-0.54
WAVE	23/11/2022 14:44	0.04	3.40	28	8.903	0.241	81.00	1.10	-0.72

Name	Date Time	Significant Height(m)	Peak Time(sec)	Peak Direction (degree)	ADCP Depth(m)	Current Speed(m/s)	Current Direction (degree)	water level reference to CD	water level reference to 1.82 SHD
WAVE	23/11/2022 14:54	0.06	9.10	138	8.822	0.219	77.00	1.02	-0.80
WAVE	23/11/2022 15:04	0.07	3.40	58	8.745	0.204	78.00	0.94	-0.88
WAVE	23/11/2022 15:14	0.11	2.20	322	8.683	0.166	71.00	0.88	-0.94
WAVE	23/11/2022 15:24	0.12	4.30	70	8.615	0.154	71.00	0.82	-1.01
WAVE	23/11/2022 15:34	0.12	2.90	80	8.564	0.093	78.00	0.76	-1.06
WAVE	23/11/2022 15:44	0.11	3.80	190	8.51	0.107	67.00	0.71	-1.11
WAVE	23/11/2022 15:54	0.08	4.90	18	8.445	0.071	75.00	0.65	-1.18
WAVE	23/11/2022 16:04	0.11	2.90	278	8.406	0.016	92.00	0.61	-1.21
WAVE	23/11/2022 16:14	0.07	3.60	62	8.378	0.034	213.00	0.58	-1.24
WAVE	23/11/2022 16:24	0.10	2.70	314	8.363	0.061	292.00	0.56	-1.26
WAVE	23/11/2022 16:34	0.08	2.80	278	8.351	0.081	300.00	0.55	-1.27
WAVE	23/11/2022 16:44	0.08	3.00	210	8.347	0.112	293.00	0.55	-1.27
WAVE	23/11/2022 16:54	0.06	4.00	90	8.356	0.12	284.00	0.56	-1.26
WAVE	23/11/2022 17:04	0.12	2.30	302	8.372	0.098	288.00	0.57	-1.25
WAVE	23/11/2022 17:14	0.15	2.60	134	8.406	0.109	297.00	0.61	-1.21
WAVE	23/11/2022 17:24	0.13	3.60	244	8.434	0.118	289.00	0.63	-1.19
WAVE	23/11/2022 17:34	0.11	2.50	106	8.475	0.21	255.00	0.68	-1.15
WAVE	23/11/2022 17:44	0.04	9.10	28	8.538	0.239	259.00	0.74	-1.08
WAVE	23/11/2022 17:54	0.06	16.00	238	8.599	0.268	252.00	0.80	-1.02
WAVE	23/11/2022 18:04	0.14	2.90	292	8.673	0.336	252.00	0.87	-0.95
WAVE	23/11/2022 18:14	0.08	2.80	242	8.738	0.34	259.00	0.94	-0.88
WAVE	23/11/2022 18:24	0.03	21.30	242	8.812	0.382	253.00	1.01	-0.81
WAVE	23/11/2022 18:34	0.06	8.00	174	8.888	0.374	257.00	1.09	-0.73
WAVE	23/11/2022 18:44	0.05	3.80	6	8.963	0.433	255.00	1.16	-0.66
WAVE	23/11/2022 18:54	0.07	4.00	26	9.051	0.415	260.00	1.25	-0.57
WAVE	23/11/2022 19:04	0.07	3.20	238	9.148	0.47	257.00	1.35	-0.47
WAVE	23/11/2022 19:14	0.03	12.80	114	9.248	0.46	260.00	1.45	-0.37
WAVE	23/11/2022 19:24	0.07	3.20	310	9.353	0.347	255.00	1.55	-0.27
WAVE	23/11/2022 19:34	0.04	9.10	66	9.434	0.325	258.00	1.63	-0.19
WAVE	23/11/2022 19:44	0.02	9.10	242	9.504	0.319	263.00	1.70	-0.12
WAVE	23/11/2022 19:54	0.08	12.80	28	9.587	0.345	259.00	1.79	-0.03
WAVE	23/11/2022 20:04	0.02	9.10	202	9.662	0.308	251.00	1.86	0.04
WAVE	23/11/2022 20:14	0.10	3.40	242	9.743	0.322	253.00	1.94	0.12
WAVE	23/11/2022 20:24	0.02	9.10	330	9.828	0.339	260.00	2.03	0.21
WAVE	23/11/2022 20:34	0.08	21.30	130	9.924	0.305	254.00	2.12	0.30
WAVE	23/11/2022 20:44	0.07	10.70	238	10.01	0.304	256.00	2.21	0.39
WAVE	23/11/2022 20:54	0.04	10.70	306	10.093	0.312	259.00	2.29	0.47
WAVE	23/11/2022 21:04	0.16	2.40	134	10.19	0.283	257.00	2.39	0.57
WAVE	23/11/2022 21:14	0.06	10.70	226	10.241	0.311	251.00	2.44	0.62
WAVE	23/11/2022 21:24	0.08	3.40	306	10.344	0.299	258.00	2.54	0.72
WAVE	23/11/2022 21:34	0.07	10.70	282	10.429	0.324	254.00	2.63	0.81
WAVE	23/11/2022 21:44	0.09	2.50	274	10.508	0.345	254.00	2.71	0.89
WAVE	23/11/2022 21:54	0.03	12.80	30	10.576	0.347	255.00	2.78	0.96
WAVE	23/11/2022 22:04	0.02	21.30	262	10.651	0.321	255.00	2.85	1.03
WAVE	23/11/2022 22:14	0.08	10.70	310	10.711	0.319	254.00	2.91	1.09
WAVE	23/11/2022 22:24	0.10	3.20	174	10.78	0.309	259.00	2.98	1.16
WAVE	23/11/2022 22:34	0.07	3.80	258	10.845	0.261	259.00	3.05	1.23
WAVE	23/11/2022 22:44	0.06	21.30	134	10.879	0.231	249.00	3.08	1.26
WAVE	23/11/2022 22:54	0.16	2.20	270	10.925	0.215	254.00	3.13	1.31
WAVE	23/11/2022 23:04	0.04	9.10	254	10.957	0.19	264.00	3.16	1.34
WAVE	23/11/2022 23:14	0.10	3.60	166	10.976	0.176	251.00	3.18	1.36
WAVE	23/11/2022 23:24	0.03	12.80	246	10.992	0.111	238.00	3.19	1.37
WAVE	23/11/2022 23:34	0.05	3.80	230	10.974	0.056	217.00	3.17	1.35
WAVE	23/11/2022 23:44	0.08	2.90	22	10.988	0.042	141.00	3.19	1.37
WAVE	23/11/2022 23:54	0.09	10.70	230	10.966	0.233	64.00	3.17	1.35
WAVE	24/11/2022 00:04	0.06	9.10	28	10.949	0.259	54.00	3.15	1.33
WAVE	24/11/2022 00:14	0.05	16.00	94	10.913	0.281	58.00	3.11	1.29
WAVE	24/11/2022 00:24	0.05	7.10	286	10.869	0.32	63.00	3.07	1.25
WAVE	24/11/2022 00:34	0.03	10.70	258	10.82	0.311	58.00	3.02	1.20
WAVE	24/11/2022 00:44	0.08	10.70	134	10.775	0.329	64.00	2.98	1.16
WAVE	24/11/2022 00:54	0.06	10.70	294	10.726	0.372	63.00	2.93	1.11
WAVE	24/11/2022 01:04	0.04	10.70	338	10.654	0.435	66.00	2.85	1.03
WAVE	24/11/2022 01:14	0.08	21.30	290	10.604	0.383	67.00	2.80	0.98
WAVE	24/11/2022 01:24	0.08	5.80	28	10.539	0.35	65.00	2.74	0.92

Name	Date Time	Significant Height(m)	Peak Time(sec)	Peak Direction (degree)	ADCP Depth(m)	Current Speed(m/s)	Current Direction (degree)	water level reference to CD	water level reference to 1.82 SHD
WAVE	24/11/2022 01:34	0.08	3.20	222	10.46	0.35	68.00	2.66	0.84
WAVE	24/11/2022 01:44	0.04	10.70	138	10.382	0.347	66.00	2.58	0.76
WAVE	24/11/2022 01:54	0.28	2.10	178	10.3	0.335	68.00	2.50	0.68
WAVE	24/11/2022 02:04	0.12	2.60	158	10.199	0.346	68.00	2.40	0.58
WAVE	24/11/2022 02:14	0.06	12.80	118	10.12	0.347	73.00	2.32	0.50
WAVE	24/11/2022 02:24	0.09	9.10	282	10.039	0.337	77.00	2.24	0.42
WAVE	24/11/2022 02:34	0.16	2.60	214	9.933	0.314	81.00	2.13	0.31
WAVE	24/11/2022 02:44	0.03	21.30	70	9.85	0.307	82.00	2.05	0.23
WAVE	24/11/2022 02:54	0.05	21.30	74	9.762	0.338	80.00	1.96	0.14
WAVE	24/11/2022 03:04	0.03	12.80	114	9.67	0.367	78.00	1.87	0.05
WAVE	24/11/2022 03:14	0.04	21.30	142	9.579	0.364	77.00	1.78	-0.04
WAVE	24/11/2022 03:24	0.03	16.00	28	9.492	0.355	77.00	1.69	-0.13
WAVE	24/11/2022 03:34	0.03	16.00	28	9.408	0.328	78.00	1.61	-0.21
WAVE	24/11/2022 03:44	0.09	2.60	134	9.326	0.279	81.00	1.53	-0.29
WAVE	24/11/2022 03:54	0.07	3.60	186	9.259	0.276	77.00	1.46	-0.36
WAVE	24/11/2022 04:04	0.07	4.00	142	9.178	0.242	78.00	1.38	-0.44
WAVE	24/11/2022 04:14	0.07	9.10	86	9.119	0.214	77.00	1.32	-0.50
WAVE	24/11/2022 04:24	0.08	9.10	328	9.079	0.155	79.00	1.28	-0.54
WAVE	24/11/2022 04:34	0.07	3.00	22	9.034	0.089	69.00	1.23	-0.59
WAVE	24/11/2022 04:44	0.07	16.00	286	9.006	0.044	67.00	1.21	-0.61
WAVE	24/11/2022 04:54	0.06	5.30	134	8.995	0.005	313.00	1.20	-0.63
WAVE	24/11/2022 05:04	0.04	12.80	6	9.007	0.124	272.00	1.21	-0.61
WAVE	24/11/2022 05:14	0.17	2.20	294	9.016	0.152	271.00	1.22	-0.60
WAVE	24/11/2022 05:24	0.06	21.30	298	9.034	0.188	268.00	1.23	-0.59
WAVE	24/11/2022 05:34	0.03	21.30	26	9.057	0.164	282.00	1.26	-0.56
WAVE	24/11/2022 05:44	0.07	3.80	314	9.088	0.188	273.00	1.29	-0.53
WAVE	24/11/2022 05:54	0.06	16.00	262	9.129	0.175	267.00	1.33	-0.49
WAVE	24/11/2022 06:04	0.02	16.00	56	9.18	0.226	260.00	1.38	-0.44
WAVE	24/11/2022 06:14	0.10	2.70	226	9.255	0.253	254.00	1.46	-0.36
WAVE	24/11/2022 06:24	0.09	3.40	28	9.303	0.328	253.00	1.50	-0.32
WAVE	24/11/2022 06:34	0.11	2.80	62	9.39	0.275	258.00	1.59	-0.23
WAVE	24/11/2022 06:44	0.03	12.80	110	9.462	0.29	252.00	1.66	-0.16
WAVE	24/11/2022 06:54	0.07	2.80	130	9.525	0.292	257.00	1.73	-0.09
WAVE	24/11/2022 07:04	0.06	5.80	28	9.593	0.23	255.00	1.79	-0.03
WAVE	24/11/2022 07:14	0.11	2.40	106	9.648	0.237	256.00	1.85	0.03
WAVE	24/11/2022 07:24	0.08	3.80	80	9.718	0.304	263.00	1.92	0.10
WAVE	24/11/2022 07:34	0.09	3.40	254	9.789	0.308	264.00	1.99	0.17
WAVE	24/11/2022 07:44	0.03	21.30	350	9.869	0.228	262.00	2.07	0.25
WAVE	24/11/2022 07:54	0.17	2.70	94	9.923	0.212	250.00	2.12	0.30
WAVE	24/11/2022 08:04	0.04	6.40	150	10.012	0.284	263.00	2.21	0.39
WAVE	24/11/2022 08:14	0.26	4.00	123	10.094	0.248	255.00	2.29	0.47
WAVE	24/11/2022 08:24	0.05	8.00	290	10.17	0.29	258.00	2.37	0.55
WAVE	24/11/2022 08:34	0.07	3.80	138	10.25	0.299	258.00	2.45	0.63
WAVE	24/11/2022 08:44	0.07	9.10	258	10.349	0.3	259.00	2.55	0.73
WAVE	24/11/2022 08:54	0.06	5.80	350	10.432	0.32	251.00	2.63	0.81
WAVE	24/11/2022 09:04	0.12	3.60	256	10.515	0.329	251.00	2.72	0.90
WAVE	24/11/2022 09:14	0.07	3.40	234	10.606	0.356	249.00	2.81	0.99
WAVE	24/11/2022 09:24	0.13	2.50	254	10.678	0.337	247.00	2.88	1.06
WAVE	24/11/2022 09:34	0.06	6.40	202	10.747	0.314	252.00	2.95	1.13
WAVE	24/11/2022 09:44	0.11	3.00	284	10.82	0.289	252.00	3.02	1.20
WAVE	24/11/2022 09:54	0.06	16.00	266	10.885	0.236	251.00	3.09	1.27
WAVE	24/11/2022 10:04	0.09	8.00	302	10.943	0.23	252.00	3.14	1.32
WAVE	24/11/2022 10:14	0.21	2.90	116	10.995	0.2	252.00	3.20	1.38
WAVE	24/11/2022 10:24	0.23	2.80	114	11.034	0.204	250.00	3.23	1.41
WAVE	24/11/2022 10:34	0.20	2.70	122	11.067	0.181	259.00	3.27	1.45
WAVE	24/11/2022 10:44	0.04	21.30	142	11.081	0.125	269.00	3.28	1.46
WAVE	24/11/2022 10:54	0.13	2.50	298	11.091	0.076	313.00	3.29	1.47
WAVE	24/11/2022 11:04	0.04	12.80	154	11.072	0.023	329.00	3.27	1.45
WAVE	24/11/2022 11:14	0.08	2.80	134	11.054	0.112	85.00	3.25	1.43
WAVE	24/11/2022 11:24	0.06	6.40	2	11.018	0.237	77.00	3.22	1.40
WAVE	24/11/2022 11:34	0.03	8.00	314	10.985	0.258	70.00	3.19	1.37
WAVE	24/11/2022 11:44	0.19	3.40	105	10.919	0.308	67.00	3.12	1.30
WAVE	24/11/2022 11:54	0.06	6.40	190	10.874	0.291	64.00	3.07	1.25
WAVE	24/11/2022 12:04	0.11	4.30	104	10.813	0.444	61.00	3.01	1.19

Name	Date Time	Significant Height(m)	Peak Time(sec)	Peak Direction (degree)	ADCP Depth(m)	Current Speed(m/s)	Current Direction (degree)	water level reference to CD	water level reference to 1.82 SHD
WAVE	24/11/2022 12:14	0.17	2.60	274	10.748	0.499	59.00	2.95	1.13
WAVE	24/11/2022 12:24	0.09	2.90	22	10.67	0.461	67.00	2.87	1.05
WAVE	24/11/2022 12:34	0.05	12.80	212	10.599	0.436	69.00	2.80	0.98
WAVE	24/11/2022 12:44	0.08	3.80	106	10.515	0.437	68.00	2.72	0.90
WAVE	24/11/2022 12:54	0.09	3.60	108	10.421	0.349	70.00	2.62	0.80
WAVE	24/11/2022 13:04	0.06	16.00	234	10.339	0.326	82.00	2.54	0.72
WAVE	24/11/2022 13:14	0.05	6.40	314	10.203	0.329	77.00	2.40	0.58
WAVE	24/11/2022 13:24	0.04	9.10	150	10.113	0.35	77.00	2.31	0.49
WAVE	24/11/2022 13:34	0.09	3.00	102	10.008	0.385	77.00	2.21	0.39
WAVE	24/11/2022 13:44	0.07	3.60	86	9.894	0.399	75.00	2.09	0.27
WAVE	24/11/2022 13:54	0.10	2.70	298	9.781	0.401	77.00	1.98	0.16
WAVE	24/11/2022 14:04	0.06	3.60	206	9.676	0.411	78.00	1.88	0.06
WAVE	24/11/2022 14:14	0.08	4.30	28	9.566	0.415	76.00	1.77	-0.05
WAVE	24/11/2022 14:24	0.08	6.40	318	9.456	0.406	78.00	1.66	-0.16
WAVE	24/11/2022 14:34	0.08	3.20	122	9.349	0.427	78.00	1.55	-0.27
WAVE	24/11/2022 14:44	0.13	3.40	76	9.218	0.44	74.00	1.42	-0.40
WAVE	24/11/2022 14:54	0.10	2.80	30	9.102	0.415	75.00	1.30	-0.52
WAVE	24/11/2022 15:04	0.08	5.80	110	8.975	0.41	76.00	1.18	-0.65
WAVE	24/11/2022 15:14	0.11	2.40	326	8.889	0.355	74.00	1.09	-0.73
WAVE	24/11/2022 15:24	0.13	2.90	102	8.798	0.329	74.00	1.00	-0.82
WAVE	24/11/2022 15:34	0.11	3.60	86	8.71	0.311	75.00	0.91	-0.91
WAVE	24/11/2022 15:44	0.14	3.20	118	8.618	0.256	73.00	0.82	-1.00
WAVE	24/11/2022 15:54	0.12	2.30	318	8.536	0.198	73.00	0.74	-1.08
WAVE	24/11/2022 16:04	0.08	2.90	60	8.456	0.151	71.00	0.66	-1.16
WAVE	24/11/2022 16:14	0.04	9.10	28	8.4	0.119	67.00	0.60	-1.22
WAVE	24/11/2022 16:24	0.06	9.10	310	8.333	0.079	58.00	0.53	-1.29
WAVE	24/11/2022 16:34	0.14	2.50	106	8.303	0.057	54.00	0.50	-1.32
WAVE	24/11/2022 16:44	0.19	2.80	134	8.266	0.084	29.00	0.47	-1.35
WAVE	24/11/2022 16:54	0.17	2.70	104	8.23	0.077	327.00	0.43	-1.39
WAVE	24/11/2022 17:04	0.09	4.30	70	8.208	0.098	279.00	0.41	-1.41
WAVE	24/11/2022 17:14	0.12	3.00	218	8.189	0.114	277.00	0.39	-1.43
WAVE	24/11/2022 17:24	0.08	4.00	234	8.181	0.106	316.00	0.38	-1.44
WAVE	24/11/2022 17:34	0.08	3.60	230	8.195	0.085	297.00	0.40	-1.43
WAVE	24/11/2022 17:44	0.03	12.80	254	8.222	0.079	294.00	0.42	-1.40
WAVE	24/11/2022 17:54	0.09	9.10	28	8.256	0.094	286.00	0.46	-1.36
WAVE	24/11/2022 18:04	0.04	12.80	246	8.313	0.124	286.00	0.51	-1.31
WAVE	24/11/2022 18:14	0.14	2.10	350	8.374	0.138	275.00	0.57	-1.25
WAVE	24/11/2022 18:24	0.07	3.40	318	8.431	0.189	257.00	0.63	-1.19
WAVE	24/11/2022 18:34	0.13	2.10	278	8.493	0.25	254.00	0.69	-1.13
WAVE	24/11/2022 18:44	0.13	2.50	58	8.557	0.298	255.00	0.76	-1.06
WAVE	24/11/2022 18:54	0.06	9.10	298	8.623	0.33	258.00	0.82	-1.00
WAVE	24/11/2022 19:04	0.07	3.00	222	8.737	0.385	258.00	0.94	-0.88
WAVE	24/11/2022 19:14	0.16	2.20	106	8.828	0.396	256.00	1.03	-0.79
WAVE	24/11/2022 19:24	0.08	3.40	122	8.921	0.409	255.00	1.12	-0.70
WAVE	24/11/2022 19:34	0.05	12.80	234	9.023	0.516	257.00	1.22	-0.60
WAVE	24/11/2022 19:44	0.04	12.80	134	9.118	0.6	263.00	1.32	-0.50
WAVE	24/11/2022 19:54	0.07	7.10	166	9.217	0.518	259.00	1.42	-0.40
WAVE	24/11/2022 20:04	0.03	9.10	114	9.338	0.422	259.00	1.54	-0.28
WAVE	24/11/2022 20:14	0.03	10.70	222	9.422	0.399	256.00	1.62	-0.20
WAVE	24/11/2022 20:24	0.07	2.90	114	9.526	0.464	258.00	1.73	-0.09
WAVE	24/11/2022 20:34	0.09	10.70	322	9.619	0.412	254.00	1.82	0.00
WAVE	24/11/2022 20:44	0.03	10.70	126	9.713	0.355	257.00	1.91	0.09
WAVE	24/11/2022 20:54	0.04	12.80	306	9.802	0.345	258.00	2.00	0.18
WAVE	24/11/2022 21:04	0.19	2.10	82	9.898	0.345	261.00	2.10	0.28
WAVE	24/11/2022 21:14	0.07	7.10	222	9.971	0.347	260.00	2.17	0.35
WAVE	24/11/2022 21:24	0.09	3.00	214	10.07	0.299	257.00	2.27	0.45
WAVE	24/11/2022 21:34	0.17	16.00	242	10.165	0.289	253.00	2.37	0.54
WAVE	24/11/2022 21:44	0.06	4.60	30	10.235	0.241	254.00	2.44	0.62
WAVE	24/11/2022 21:54	0.15	2.30	254	10.328	0.249	260.00	2.53	0.71
WAVE	24/11/2022 22:04	0.05	4.60	28	10.426	0.286	251.00	2.63	0.81
WAVE	24/11/2022 22:14	0.07	12.80	28	10.51	0.301	255.00	2.71	0.89
WAVE	24/11/2022 22:24	0.11	21.30	282	10.577	0.326	254.00	2.78	0.96
WAVE	24/11/2022 22:34	0.04	9.10	250	10.67	0.34	253.00	2.87	1.05
WAVE	24/11/2022 22:44	0.06	10.70	28	10.754	0.344	252.00	2.95	1.13

Name	Date Time	Significant Height(m)	Peak Time(sec)	Peak Direction (degree)	ADCP Depth(m)	Current Speed(m/s)	Current Direction (degree)	water level reference to CD	water level reference to 1.82 SHD
WAVE	24/11/2022 22:54	0.12	2.90	210	10.826	0.347	252.00	3.03	1.21
WAVE	24/11/2022 23:14	0.05	7.10	206	11.005	0.376	253.00	3.21	1.39
WAVE	24/11/2022 23:24	0.06	10.70	134	11.076	0.385	256.00	3.28	1.46
WAVE	24/11/2022 23:34	0.06	8.00	154	11.147	0.357	256.00	3.35	1.53
WAVE	24/11/2022 23:44	0.02	12.80	326	11.196	0.317	261.00	3.40	1.58
WAVE	24/11/2022 23:54	0.02	9.10	162	11.258	0.281	262.00	3.46	1.64
WAVE	25/11/2022 00:04	0.04	7.10	170	11.247	0.224	263.00	3.45	1.63
WAVE	25/11/2022 00:14	0.03	12.80	28	11.283	0.162	265.00	3.48	1.66
WAVE	25/11/2022 00:24	0.04	8.00	302	11.281	0.135	258.00	3.48	1.66
WAVE	25/11/2022 00:34	0.12	2.50	306	11.29	0.066	252.00	3.49	1.67
WAVE	25/11/2022 00:44	0.03	10.70	230	11.272	0.066	88.00	3.47	1.65
WAVE	25/11/2022 00:54	0.10	2.70	122	11.232	0.38	73.00	3.43	1.61
WAVE	25/11/2022 01:04	0.04	9.10	326	11.18	0.324	69.00	3.38	1.56
WAVE	25/11/2022 01:14	0.09	3.20	236	11.133	0.292	60.00	3.33	1.51
WAVE	25/11/2022 01:24	0.03	9.10	28	11.078	0.41	59.00	3.28	1.46
WAVE	25/11/2022 01:34	0.11	3.00	106	10.994	0.407	61.00	3.19	1.37
WAVE	25/11/2022 01:44	0.03	12.80	186	10.947	0.418	63.00	3.15	1.33
WAVE	25/11/2022 01:54	0.07	9.10	214	10.876	0.474	69.00	3.08	1.26
WAVE	25/11/2022 02:04	0.05	7.10	246	10.795	0.509	71.00	3.00	1.18
WAVE	25/11/2022 02:14	0.02	9.10	214	10.705	0.475	71.00	2.91	1.09
WAVE	25/11/2022 02:24	0.08	3.40	138	10.613	0.432	71.00	2.81	0.99
WAVE	25/11/2022 02:34	0.04	10.70	346	10.53	0.393	69.00	2.73	0.91
WAVE	25/11/2022 02:44	0.07	3.20	58	10.43	0.362	75.00	2.63	0.81
WAVE	25/11/2022 02:54	0.07	4.60	202	10.323	0.315	78.00	2.52	0.70
WAVE	25/11/2022 03:04	0.05	6.40	298	10.202	0.335	83.00	2.40	0.58
WAVE	25/11/2022 03:14	0.07	9.10	278	10.094	0.355	78.00	2.29	0.47
WAVE	25/11/2022 03:24	0.05	4.30	290	9.995	0.399	74.00	2.20	0.37
WAVE	25/11/2022 03:34	0.07	6.40	28	9.884	0.403	80.00	2.08	0.26
WAVE	25/11/2022 03:44	0.03	9.10	242	9.777	0.396	78.00	1.98	0.16
WAVE	25/11/2022 03:54	0.09	16.00	28	9.687	0.35	78.00	1.89	0.07
WAVE	25/11/2022 04:04	0.04	21.30	258	9.599	0.336	85.00	1.80	-0.02
WAVE	25/11/2022 04:14	0.05	21.30	28	9.518	0.319	80.00	1.72	-0.10
WAVE	25/11/2022 04:24	0.08	2.70	54	9.435	0.287	84.00	1.64	-0.18
WAVE	25/11/2022 04:34	0.10	2.30	206	9.362	0.256	78.00	1.56	-0.26
WAVE	25/11/2022 04:44	0.05	7.10	28	9.309	0.216	74.00	1.51	-0.31
WAVE	25/11/2022 04:54	0.06	16.00	318	9.261	0.201	70.00	1.46	-0.36
WAVE	25/11/2022 05:04	0.04	6.40	326	9.224	0.117	64.00	1.42	-0.40
WAVE	25/11/2022 05:14	0.04	10.70	250	9.186	0.092	60.00	1.39	-0.43
WAVE	25/11/2022 05:24	0.03	21.30	28	9.158	0.075	65.00	1.36	-0.46
WAVE	25/11/2022 05:34	0.09	4.00	230	9.174	0.015	95.00	1.37	-0.45
WAVE	25/11/2022 05:44	0.03	10.70	178	9.184	0.088	262.00	1.38	-0.44
WAVE	25/11/2022 05:54	0.02	10.70	266	9.209	0.186	257.00	1.41	-0.41
WAVE	25/11/2022 06:04	0.05	5.80	150	9.251	0.253	272.00	1.45	-0.37
WAVE	25/11/2022 06:14	0.03	12.80	270	9.293	0.221	269.00	1.49	-0.33
WAVE	25/11/2022 06:24	0.11	2.90	242	9.347	0.229	269.00	1.55	-0.27
WAVE	25/11/2022 06:34	0.05	2.90	214	9.391	0.302	256.00	1.59	-0.23
WAVE	25/11/2022 06:44	0.11	2.30	202	9.452	0.285	256.00	1.65	-0.17
WAVE	25/11/2022 06:54	0.09	2.60	214	9.495	0.316	260.00	1.70	-0.13
WAVE	25/11/2022 07:04	0.04	9.10	238	9.568	0.296	257.00	1.77	-0.05
WAVE	25/11/2022 07:14	0.11	2.40	318	9.631	0.233	255.00	1.83	0.01
WAVE	25/11/2022 07:24	0.04	4.90	28	9.702	0.25	251.00	1.90	0.08
WAVE	25/11/2022 07:34	0.07	7.10	250	9.766	0.246	267.00	1.97	0.15
WAVE	25/11/2022 07:44	0.12	2.40	14	9.84	0.24	265.00	2.04	0.22
WAVE	25/11/2022 07:54	0.04	7.10	230	9.901	0.247	260.00	2.10	0.28
WAVE	25/11/2022 08:04	0.10	2.80	118	9.961	0.254	260.00	2.16	0.34
WAVE	25/11/2022 08:14	0.02	10.70	154	10.022	0.206	258.00	2.22	0.40
WAVE	25/11/2022 08:24	0.12	2.40	120	10.066	0.282	266.00	2.27	0.45
WAVE	25/11/2022 08:34	0.02	10.70	350	10.129	0.266	267.00	2.33	0.51
WAVE	25/11/2022 08:44	0.06	9.10	28	10.198	0.224	270.00	2.40	0.58
WAVE	25/11/2022 08:54	0.08	4.90	28	10.268	0.264	271.00	2.47	0.65
WAVE	25/11/2022 09:04	0.12	3.00	126	10.322	0.23	254.00	2.52	0.70
WAVE	25/11/2022 09:14	0.17	3.20	115	10.396	0.196	244.00	2.60	0.78
WAVE	25/11/2022 09:24	0.11	2.70	110	10.469	0.232	253.00	2.67	0.85
WAVE	25/11/2022 09:34	0.17	2.70	108	10.539	0.257	253.00	2.74	0.92

Name	Date Time	Significant Height(m)	Peak Time(sec)	Peak Direction (degree)	ADCP Depth(m)	Current Speed(m/s)	Current Direction (degree)	water level reference to CD	water level reference to 1.82 SHD
WAVE	25/11/2022 09:44	0.12	2.70	119	10.61	0.275	254.00	2.81	0.99
WAVE	25/11/2022 09:54	0.12	2.80	126	10.676	0.271	249.00	2.88	1.06
WAVE	25/11/2022 10:04	0.04	10.70	326	10.741	0.287	254.00	2.94	1.12
WAVE	25/11/2022 10:14	0.06	3.80	190	10.812	0.28	255.00	3.01	1.19
WAVE	25/11/2022 10:24	0.06	12.80	298	10.872	0.258	253.00	3.07	1.25
WAVE	25/11/2022 10:34	0.09	4.00	232	10.931	0.236	255.00	3.13	1.31
WAVE	25/11/2022 10:44	0.09	2.80	118	10.966	0.2	256.00	3.17	1.35
WAVE	25/11/2022 10:54	0.19	2.70	86	11.022	0.187	252.00	3.22	1.40
WAVE	25/11/2022 11:04	0.14	2.70	126	11.066	0.201	251.00	3.27	1.45
WAVE	25/11/2022 11:14	0.20	2.80	277	11.091	0.164	255.00	3.29	1.47
WAVE	25/11/2022 11:24	0.09	3.20	214	11.105	0.107	262.00	3.31	1.49
WAVE	25/11/2022 11:34	0.06	8.00	146	11.109	0.059	264.00	3.31	1.49
WAVE	25/11/2022 11:44	0.18	3.60	301	11.103	0.014	254.00	3.30	1.48
WAVE	25/11/2022 11:54	0.14	2.80	100	11.076	0.043	94.00	3.28	1.46
WAVE	25/11/2022 12:04	0.15	3.00	223	11.061	0.106	67.00	3.26	1.44
WAVE	25/11/2022 12:14	0.20	2.80	100	11.007	0.138	71.00	3.21	1.39
WAVE	25/11/2022 12:24	0.08	2.60	18	10.964	0.29	74.00	3.16	1.34
WAVE	25/11/2022 12:34	0.09	2.90	110	10.915	0.338	72.00	3.12	1.30
WAVE	25/11/2022 12:44	0.03	9.10	138	10.851	0.355	68.00	3.05	1.23
WAVE	25/11/2022 12:54	0.06	3.40	62	10.778	0.397	67.00	2.98	1.16
WAVE	25/11/2022 13:04	0.07	9.10	28	10.703	0.363	70.00	2.90	1.08
WAVE	25/11/2022 13:14	0.04	16.00	170	10.622	0.374	72.00	2.82	1.00
WAVE	25/11/2022 13:24	0.06	16.00	70	10.528	0.391	67.00	2.73	0.91
WAVE	25/11/2022 13:34	0.07	3.60	326	10.433	0.466	67.00	2.63	0.81
WAVE	25/11/2022 13:44	0.17	3.20	88	10.324	0.37	77.00	2.52	0.70
WAVE	25/11/2022 13:54	0.07	16.00	10	10.214	0.389	78.00	2.41	0.59
WAVE	25/11/2022 14:04	0.17	2.70	304	10.104	0.383	81.00	2.30	0.48
WAVE	25/11/2022 14:14	0.09	3.80	70	9.993	0.378	80.00	2.19	0.37
WAVE	25/11/2022 14:24	0.14	3.00	78	9.874	0.379	81.00	2.07	0.25
WAVE	25/11/2022 14:34	0.09	3.80	98	9.755	0.389	80.00	1.96	0.14
WAVE	25/11/2022 14:44	0.11	9.10	154	9.637	0.425	80.00	1.84	0.02
WAVE	25/11/2022 14:54	0.07	3.20	262	9.514	0.436	77.00	1.71	-0.11
WAVE	25/11/2022 15:04	0.04	6.40	190	9.391	0.446	77.00	1.59	-0.23
WAVE	25/11/2022 15:14	0.12	2.40	202	9.268	0.434	76.00	1.47	-0.35
WAVE	25/11/2022 15:24	0.06	4.00	74	9.141	0.44	75.00	1.34	-0.48
WAVE	25/11/2022 15:34	0.03	12.80	90	9.019	0.408	75.00	1.22	-0.60
WAVE	25/11/2022 15:44	0.14	2.30	28	8.915	0.387	75.00	1.12	-0.71
WAVE	25/11/2022 15:54	0.03	9.10	334	8.803	0.358	76.00	1.00	-0.82
WAVE	25/11/2022 16:04	0.05	9.10	28	8.686	0.334	76.00	0.89	-0.93
WAVE	25/11/2022 16:14	0.06	6.40	14	8.585	0.289	77.00	0.79	-1.04
WAVE	25/11/2022 16:24	0.04	12.80	122	8.484	0.248	78.00	0.68	-1.14
WAVE	25/11/2022 16:34	0.28	2.80	266	8.384	0.207	77.00	0.58	-1.24
WAVE	25/11/2022 16:44	0.13	2.60	246	8.312	0.152	76.00	0.51	-1.31
WAVE	25/11/2022 16:54	0.08	2.80	290	8.235	0.089	68.00	0.44	-1.39
WAVE	25/11/2022 17:04	0.25	2.10	130	8.174	0.061	56.00	0.37	-1.45
WAVE	25/11/2022 17:14	0.07	3.40	310	8.122	0.005	85.00	0.32	-1.50
WAVE	25/11/2022 17:24	0.08	9.10	154	8.096	0.038	329.00	0.30	-1.52
WAVE	25/11/2022 17:34	0.19	3.40	219	8.044	0.051	261.00	0.24	-1.58
WAVE	25/11/2022 17:44	0.25	2.70	242	8.024	0.175	262.00	0.22	-1.60
WAVE	25/11/2022 17:54	0.09	3.40	78	8.018	0.189	265.00	0.22	-1.60
WAVE	25/11/2022 18:04	0.34	2.90	83	8.023	0.196	287.00	0.22	-1.60
WAVE	25/11/2022 18:14	0.03	16.00	222	8.049	0.154	303.00	0.25	-1.57
WAVE	25/11/2022 18:24	0.17	3.80	241	8.066	0.137	268.00	0.27	-1.55
WAVE	25/11/2022 18:34	0.07	3.80	218	8.107	0.139	265.00	0.31	-1.51
WAVE	25/11/2022 18:44	0.09	12.80	292	8.152	0.176	265.00	0.35	-1.47
WAVE	25/11/2022 18:54	0.20	3.00	303	8.199	0.223	248.00	0.40	-1.42
WAVE	25/11/2022 19:04	0.09	12.80	82	8.263	0.219	256.00	0.46	-1.36
WAVE	25/11/2022 19:14	0.20	2.50	93	8.319	0.229	253.00	0.52	-1.30
WAVE	25/11/2022 19:24	0.07	4.60	226	8.37	0.254	256.00	0.57	-1.25
WAVE	25/11/2022 19:34	0.10	3.60	92	8.447	0.256	256.00	0.65	-1.17
WAVE	25/11/2022 19:44	0.06	8.00	50	8.539	0.244	253.00	0.74	-1.08
WAVE	25/11/2022 19:54	0.12	2.50	28	8.632	0.306	253.00	0.83	-0.99
WAVE	25/11/2022 20:04	0.06	4.90	254	8.728	0.366	253.00	0.93	-0.89
WAVE	25/11/2022 20:14	0.03	16.00	90	8.828	0.417	259.00	1.03	-0.79

Appendix S
Survey Report for Underwater
Noise Monitoring Data



YJP SURVEYORS PTE LTD

REPORT FOR

HYDROPHONE UNDERWATER NOISE

MONITORING DATA COLLECTED

AT OFFSHORE LOCATION

AT SOUTH PULAU UBIN

Prepared for:	AECOM Singapore Pte Ltd	By: YJP Surveyors Pte Ltd
----------------------	-------------------------	---------------------------

Report for Hydrophone Underwater Noise Monitoring data collected at Offshore location
at South Pulau Ubin



Contents

1	INTRODUCTION.....	3
2	METHODOLOGY.....	5
2.1	<i>DEPLOYMENT AND DATA ACQUISITION</i>	<i>5</i>
2.2	<i>DATA ANALYSIS AND PRESENTATION.....</i>	<i>6</i>
	Appendix A. PORPOISE ACOUSTIC RECORDER – 500M.....	8

Table of Figures

FIGURE 1.	PROPOSED LOCATION OF HYDROPHONE	3
FIGURE 2.	DEPLOYED LOCATION OF HYDROPHONE	4
FIGURE 3.	DEPLOYMENT DETAILS OF HYDROPHONE	5
FIGURE 4.	HYDROPHONE READY FOR DEPLOYMENT	5
FIGURE 5.	DIVER-ASSISTED DEPLOYMENT OF HYDROPHONE	6
FIGURE 6.	SAMPLE OUTPUT DATA.....	7



1 INTRODUCTION

This report presents underwater acoustic data collected from the deployment of Hydrophone PORPOISE Acoustic Recorder – 500m during underwater noise monitoring conducted on 13th and 14th December 2022 and 3rd and 4th January 2023 at an offshore location at south of Pulau Ubin for AECOM Singapore Pte Ltd. The purpose of the project (Consultancy Services for Mangrove Restoration at Sungei Durian Ponds Environmental Impact Assessment (EIA)) aims to study and assess the impacts from the ecological mangrove restoration works conducted at said location, which will restore the site elevations to encourage the reestablishment of mangroves within the abandoned prawn ponds.

The proposed location (Latitude 1°24'18.818"N, Longitude 103°58'45.956"E) for deployment of hydrophone is as shown below (Figure 1), and would be at least 25m away from the deployed ADCP. Due to technical constraints (see Section 2.1), the hydrophone was deployed at an alternative location as indicated in Figure 2.



Figure 1. Proposed Location of Hydrophone



Figure 2. Deployed Location of Hydrophone



1 METHODOLOGY

Porpoise Acoustic Recorder – 500m, full specifications on Appendix A, was deployed for underwater noise monitoring for a two-day period for two rounds of monitoring. The hydrophone was deployed on 13th December 2022 and 3rd January 2023, respectively.

1.1 DEPLOYMENT AND DATA ACQUISITION

The hydrophone was deployed in the underwater environment at the specified locations in Figure 3. The deployment area was reproped and selected as the previous location had insufficient water depth. This deployment location is of suitable water depth and current for underwater noise monitoring.

Date	Monitor Frequency	Latitude	Longitude
13 th and 14 th December 2022	192000 Hz	1.39954°	103.97423°
4 th and 5 th January 2023	384000 Hz	1.39956°	103.97398°

Figure 3. Deployment Details of Hydrophone

The Porpoise Acoustic Recorder-500m hydrophone and data logger was secured to location by using a specialized deployment frame as seen in Figure 4.

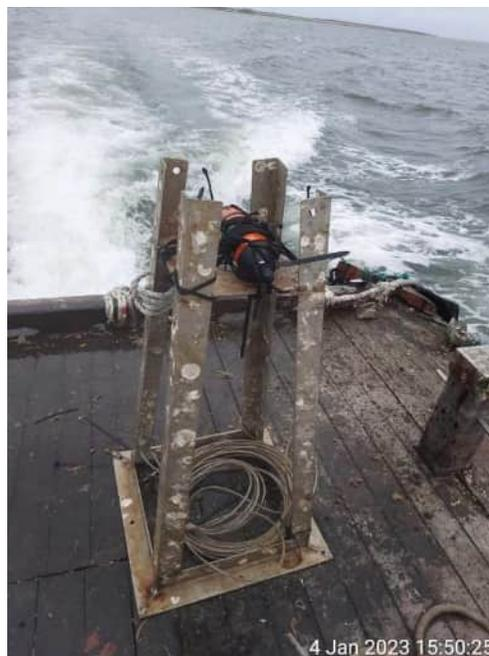

Figure 4. Hydrophone ready for deployment



Divers were commissioned to accurately position the hydrophone in the deployment location for optimal measurement accuracy while ensuring safe deployment and recovery.



Figure 5. Diver-assisted deployment of hydrophone

Data collection frequency was set on the data logger. This determined how often the data logger records and saves data from the hydrophone. Sampling frequency for 13th and 14th December 2022 was set to 192000Hz, and the sampling frequency for 3rd and 4th January 2023 was 384000Hz.

The data logger and hydrophone were monitored closely throughout the deployment to ensure that they are working correctly.

1.2 DATA ANALYSIS AND PRESENTATION

Underwater noise data from the hydrophone was downloaded and transmitted to AECOM for further analysis.



Below is a sample underwater noise frequency profile obtained from hydrophone data.

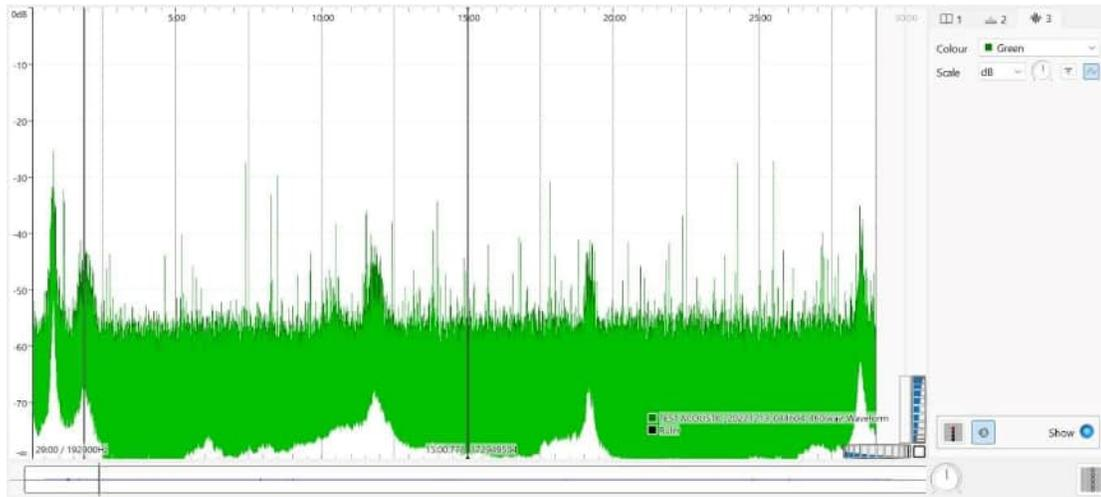

Figure 6. Sample output data



YJP SURVEYORS PTE LTD

Appendix A. PORPOISE ACOUSTIC RECORDER – 500M



The *Porpoise* underwater noise recording and signal processing system has taken all the processing power and real-time data streaming capabilities of the multichannel *Orca* acoustic recorder and compressed that into a compact and streamlined single-channel package.

With highly configurable sampling rates, gain control, hydrophone settings, intelligent on/off scheduling and real-time data processing, *Porpoise* is truly the smartest single-channel PAM system available.

KEY FEATURES

- + Up to 4TB Internal SD recording
- + Real Time Data Streaming
- + Low Power
- + Internal & External Battery Options



TRAC SOFTWARE

TRAC is *Porpoise's* proprietary configuration, analysis and display software. TRAC presents digital multichannel acoustic data including real-time spectrograms, third octave plots with percentiles, and live real-time audio.



TECHNICAL SPECIFICATIONS

*Specifications subject to change without notice

POWER Internal Power: 12 x AAA cells (user replaceable)
External Power: 6.5V – 26V

ACOUSTIC Analogue Bandwidth: 160kHz
ADC: 24 Bits Sigma Delta
Dynamic Range: 110dB (full bandwidth)
Configurable Gain: 0dB – 45dB
Maximum Sensitivity: -158.26dB Re 1 V/ μ Pa
Sampling Rates Supported: 2kHz to 384kHz
Software Controlled High Pass Filter

MEMORY Up to 4TB Internal Removable SD Card Storage
Configurable Recording, Schedule and Duty Cycling

DIMENSIONS 7cm Diameter x 23.2cm length, 1.34kg

COMMUNICATIONS Real Time Ethernet Streaming of Spectograms, Audio, Configuration and Data

ENVIRONMENTAL Depth Rating: 500m standard, 2000m available
Operating Temperature: -10c to +50c

EXTERNAL INTEGRATION GPS Input for PPS Time Synchronisation
Long Range Real Time Streaming over WiFi Via Surface Float

www.rsaqua.co.uk | info@rsaqua.co.uk | +44 (0) 2394 004 540 | 21/22 The Slipway, Marina Keep, Port Solent, Portsmouth PO6 4TR, UK

